

HEIDENHAIN

DR. JOHANNES HEIDENHAIN GmbH
D-8225 Traunreut · Tel. (08669) 31-0

Kundendienst

Service Manual TNC 155

Subject to change (without notice)

DR. JOHANNES HEIDENHAIN GmbH is constantly working on further developments of its TNC Controls. It is therefore possible that details of your Control may differ slightly from those described herein. If that is the case, please order a suitably revised issue of the Service Manual.

Copying/Duplication

This manual is provided subject to the condition that no part of it shall be reproduced in any form or by any means without our prior consent in writing.

Issue: 01/87



Kundendienst

C o n t e n t s

1. Use of the Service Manual	Page 2
2. Fault Diagnosis	" 3
2.1 Procedure for fault-finding	" 3
2.2 Flow diagrams for fault location	" 4
2.2.1 Fault diagnosis for the complete installation	" 4
2.2.2 Use of the integrated supervision system	" 5
2.2.3 Testing of the VDU and associated circuitry	" 14
2.2.4 Testing of the mains supply and the Power Supply Unit	" 15
2.2.5 Testing of the measuring systems and wiring	" 17
2.2.6 Burn-In Test	" 18
3. Exchange Information	" 36
3.1 Exchanging control units	" 37
3.1.1 Procedure for exchanging the TNC 155 A/E Control	" 37
3.1.2 Procedure for exchanging the TNC 155 P/V Control	" 38
3.1.3 Procedure for exchanging the PLC I/O Board of the PL 100 B/110 B	" 39
3.2 Board exchange	" 40
3.3 Software exchange	" 45
3.4 Replacement parts, Loan/Exchange/Service Units	" 48
4. Additional Information	" 50
4.1 Block Diagram Description	" 50
4.2 Block Diagram TNC 155	" 55
4.3 Wiring Diagrams	" 70
4.4 Machine Parameters	" 75



Kundendienst

1. Use of the Service Manual TNC 155

In order to determine the fault condition on a NC machine, a fundamental knowledge of the machine and the drives is necessary, as well as a knowledge of their interaction with the Control and measuring system. In addition, improper use of the Control, such as incorrect NC programming or incorrect selection of machine parameters can lead to the occurrence of fault conditions. Further information in this respect can be found in:

- .TNC 155 OPERATING MANUAL
- .TNC 155 MOUNTING INSTRUCTIONS AND INTERFACE CIRCUIT CONTROL-MACHINE
- .TNC 155 PLC-DESCRIPTION

The TNC 155 Service Manual is used for the diagnosis, localisation and remedying of faults on TNC controlled machines. In chapter 2, Fault Diagnosis, a set of flowdiagrams enables the user to pinpoint the source of a fault from its symptoms.

An integrated supervision system and a Burn-In Test Program specifically developed for testing the Control can aid in the location of faults.

Important guidance for the exchange of entire Controls, individual boards, or software is given in section 3, Exchange Information.

Section 4, Additional Information, contains a block diagram of the Control, a brief description of the internal electronics, a wiring diagram for each version of the Control, and a list of machine parameters with permissible entry values.

Kundendienst

2. Fault Diagnosis

2.1 Procedure for fault-finding

To locate and rectify a fault that has arisen in a TNC installation, it is of foremost importance to analyse the behaviour of the system as a whole: that is, the TNC Control, the machine-tool and the measuring system.

2.2.1 shows, in flow diagram form, the procedure for examining the complete installation.

In addition, the HEIDENHAIN TNC 155 Contouring Control includes an extensive integrated supervision system for the avoidance of entry/operator faults and for the recognition and diagnosis of technical defects in the installation (see section 2.2.2)

The Burn-In Test Program can be used as further support in fault localizing and in the dynamic testing of the Control's hardware (see section 2.2.6).

Kundendienst

2.2 Flow diagrams for fault location

**2.2.1 Fault diagnosis for the complete installation
 (Control/Measuring System/Machine-tool)**

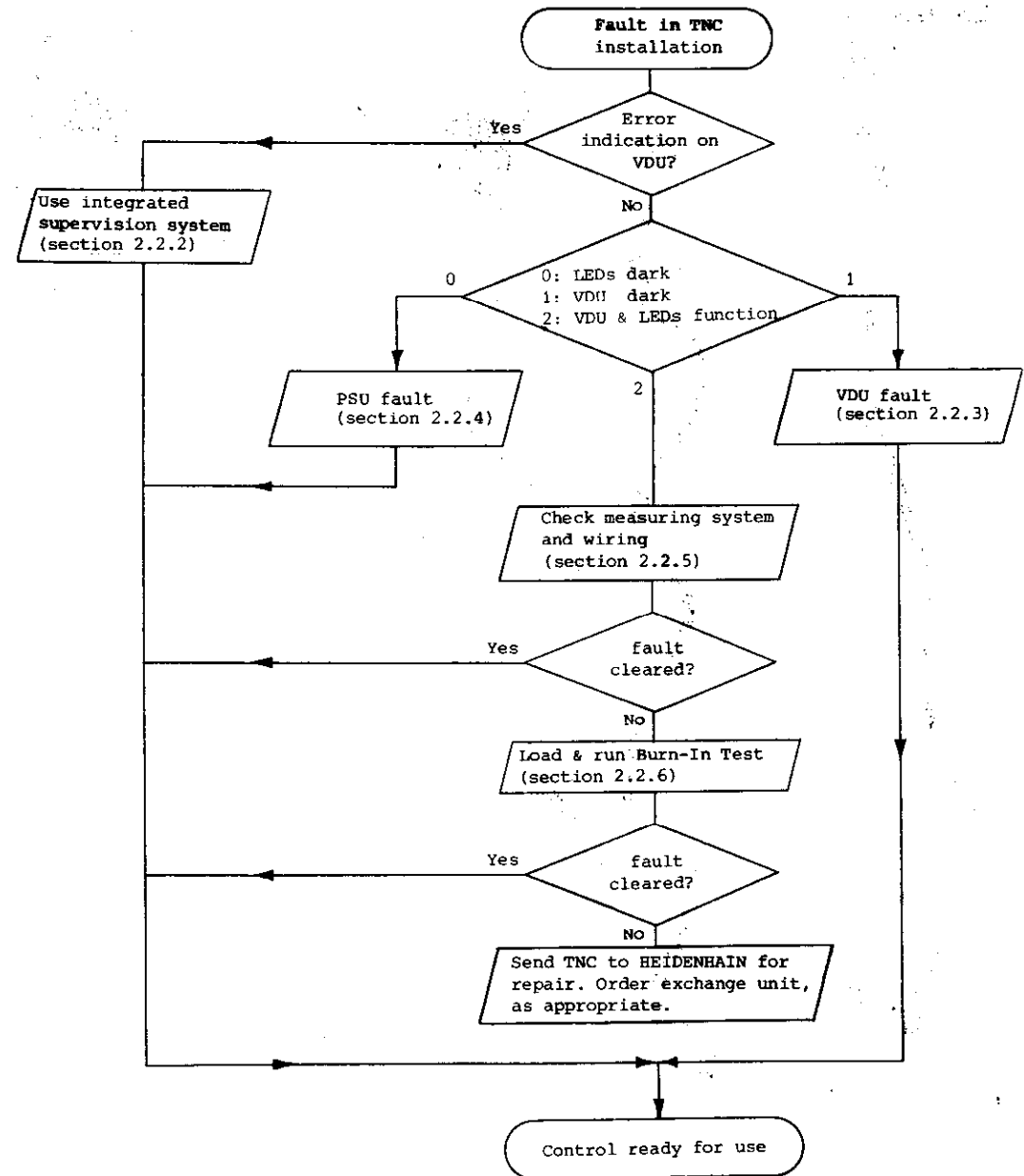

Kundendienst

2.2.2 Use of the integrated supervision system

The TNC 155 incorporates an extensive integrated supervision system for the avoidance of operator-errors and the detection and diagnosis of technical faults in the TNC installation (ie the installation comprising the TNC, the machine-tool and the measuring system).

The supervision system is made up of a mixture of hardware and software within the TNC, and operates continuously whilst the TNC is switched on. If a fault is detected, or if an operator-error occurs, a message will be displayed, indicating (in abbreviated form) the nature of the problem.

example of operator-errors:

- a) KEY NON-FUNCTIONAL
- b) ENTRY VALUE INCORRECT

example of fault with TNC internal electronics:

- a) TNC OPERATING TEMP. EXCEEDED
- b) EXCHANGE BUFFER BATTERY
- c) TNC ELECTRONICS DEFECTIVE 0...3/A...K

example of fault with measuring system:

X-MEASURING SYSTEM DEFECTIVE

example of fault on machine-tool:

GROSS POSITIONING ERROR A

The system distinguishes between what are considered to be harmless errors and serious faults, in that faults are shown as flashing displays. Examples of faults are measuring system faults, drive faults and faults in the TNC's internal electronics. The occurrence of a fault leads to the machine being switched off via the emergency-stop contactor. The fault must then be rectified before the TNC is switched on again.

Flashing fault messages TNC 155

AXIS X/Y/Z/4 MEAS. SYSTEM DEFECTIVE

EMERGENCY STOP DEFECTIVE

WRONG REFERENCE POINT

EMERGENCY STOP PLC

GROSS POSITIONING ERROR A/B/C/D

TNC OPERATING TEMP. EXCEEDED

ERROR IN PLC PROGRAM A...Q

TNC ELECTRONICS DEFECTIVE 0...3/A...K

CHECK SUM ERROR XX00...XXFF

The significance of these fault messages is explained on pages 8 to 13

A (non-flashing) error message can be cleared by pressing the **CE** key on the TNC, after which normal operation may resume. A list of error messages is given on page 7.

Kundendienst

Error message "EXCHANGE BUFFER BATTERY"

Particular mention should also be made about the implications of the instruction to exchange the buffer battery:
 If the dialogue display indicates "EXCHANGE BUFFER BATTERY", new batteries must be inserted within one week.
 The buffer battery compartment is located behind the screw cover in the lower left-hand corner of the operating panel. When exchanging the batteries, special care should be taken that the polarity is correct (POS-pole of battery outwards). The battery needs to have IEC designation "LR 6" and must be of the leak-proof type. We especially recommend the use of VARTA Alkaline batteries type "4006". With discharged (or missing) buffer batteries, the memory for the machine parameters and for the user-program will be supported only as long as the mains remains switched on. Continued operation is still possible but the memory contents will become erased in the event of a mains failure. Please note that the TNC has to be switched on when exchanging the buffer batteries. If a mains failure occurs during a battery change (or when the battery is discharged or missing), the re-entry of the machine parameters and the user-program will be necessary.

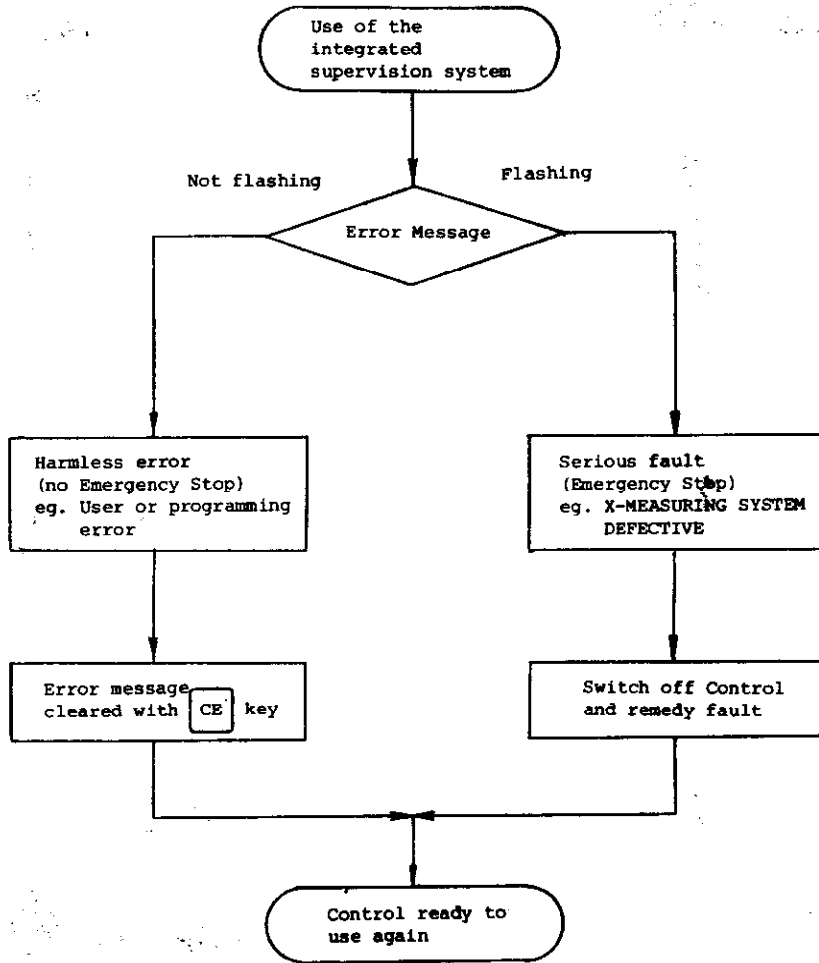

Kundendienst

Error messages TNC 155

The meanings of many of these error messages are explained in:

- (i) Operating Manual TNC 155 A/TNC 155 P
- (ii) Mounting Instructions and Interface Circuit Control-Machine TNC 155 A/TNC 155 P

KEY NON-FUNCTIONAL	LIMIT SWITCH AXIS Z+	FURTHER PROGRAM ENTRY IMPOSSIBLE
PROGRAM MEMORY EXCEEDED	LIMIT SWITCH AXIS Z-	PROGRAM NUMBER UNAVAILABLE
SEARCH ADDRESS MISSING	LIMIT SWITCH AXIS 4+	PROGRAM NUMBER ALLOCATED
TOOL DEF Ø NOT PERMITTED	LIMIT SWITCH AXIS 4-	LABEL NUMBER ALLOCATED
PROGRAM NUMBER ON TAPE ALLOCATED	EXCHANGE BUFFER BATTERY	TOOL NUMBER ALLOCATED
JUMP TO LABEL Ø NOT PERMITTED	TRANSFERRED DATA INCORRECT	RELAY EXT. DC VOLTAGE MISSING
ENTRY VALUE INCORRECT	ME: CASSETTE MISSING	POWER INTERRUPTED
CC-BLOCK MISSING	ME: CASSETTE LOCKED	PGM XXXXXXXX UNAVAILABLE
CIRCLE END POS. INCORRECT	ME: WRONG MODE SELECTED	TWO TOOL DEF XXX WITH PGM CALL
TOOL DEF MISSING	ME: WRONG PROGRAM DATA	CIRCLE CENTRE UNDEFINED XXXX
TOOL CALL MISSING	ME: CASSETTE EMPTY	ADDRESS LETTER ALREADY ASSIGNED
LABEL NUMBER NOT ALLOCATED	ME: PROGRAM INCOMPLETE	BLOCK TOO LONG
EXCESSIVE SUPROGRAMMING	ME: TAPE END	G-CODE GROUP ALREADY ALLOCATED
ANGLE REFERENCE MISSING	WRONG PROGRAM DATA	ILLEGAL G-CODE
PLANE WRONGLY DEFINED	MACHINE PARAMETER INCOMPLETE	BLOCK NUMBER ALREADY ALLOCATED
TOOL RADIUS TOO LARGE	EXT. IN-/OUTPUT NOT READY	BLOCK FORMAT INCORRECT
ROUNDING RADIUS TOO LARGE	MIRROR IMAGE ON TOOL AXIS	N-CODE MISSING
PATH OFFSET WRONGLY STARTED	WRONG AXIS PROGRAMMED	BLK FORM DEFINITION INCORRECT
PATH OFFSET WRONGLY ENDED	WRONG SIGN PROGRAMMED	PGM-SECTION CANNOT BE SHOWN
ROUNDING-OFF UNDEFINED	SPINDEL ROTATES MISSING	TOO MANY USER PARAMETERS
ROUNDING-OFF NOT PERMITTED	SLOT WIDTH TOO LARGE	PROTECTED PGM
AXIS DOUBLE PROGRAMMED	CYCLE INCOMPLETE	ILLEGAL NC-BLOCK
WRONG RPM	SELECTED BLOCK NOT ADDRESSED	CHAMFER NOT ALLOWED
NO EDITING OF RUNNING PGM	PROGRAM START UNDEFINED	
RADIUS COMP. UNDEFINED	POSITIONING ERROR	
LIMIT SWITCH X+	EMERGENCY STOP	
LIMIT SWITCH X-	ARITHMETICAL ERROR	
LIMIT SWITCH Y+	OPERATION PARAMETERS ERASED	
LIMIT SWITCH Y-	3D-INTERPOLATION NOT PERMITTED	

Kundendienst

Fault descriptions TNC 155

VDU Display (flashing)	Fault cause	Possible fault location
X-MEASURING SYSTEM DEFECTIVE Y-MEASURING SYSTEM DEFECTIVE Z-MEASURING SYSTEM DEFECTIVE AXIS 4 MEAS. SYSTEM DEFECTIVE	.Measuring system not connected .Cable damaged .Glass scale dirty or damaged .Scanning head damaged .Measuring system supervision damaged	Measuring system Analogue Board
EMERGENCY STOP DEFECTIVE	.Fault in the emergency stop circuit of the machine (for checking routine see Mounting Instructions and Interface Circuit Control-Machine manual TNC 155 A/TNC 155 P) .Defect in Control's internal Emergency Stop supervision	Analogue Board PLC I/O Board (TNC 155 P) PLC Interface Board (TNC 155 P) SE Board (TNC 155 A) Terminal Board (TNC 155 A)
WRONG REFERENCE POINT	.Traversed-over reference point lies outside of the reference point end position (also see Mounting Instructions and Interface Circuit Control-Machine TNC 155 A/TNC 155 P) .Defect in Control/machine interface	Machine (cams/switches "reference end-position" or "reference pulse inhibit") PLC I/O Board (TNC 155 P) PLC Interface Board (TNC 155 P) SE Board (TNC 155 A) Terminal Board (TNC 155 A)

Kundendienst

VDU Display (flashing)	Fault cause	Possible fault location
EMERGENCY-STOP PC	<p>With standard PLC program, faulty reply from output A6 ("Lock for spindle on") to input E20 ("reply: Lock for spindle on") Fault message EMERGENCY-STOP PC appears only when no additional PLC marker is set for the fault message</p>	Terminal board (TNC 155 A)
GROSS POSITIONING ERROR A	<p>.Trailing error greater than value entered in MP 174. (see Mounting Instructions and Interface Circuit Control-Machine manual TNC 155 A/ TNC 155 P)</p> <p>.Deviation from the intended position at standstill greater than the value entered in MP 169 (see Mounting Instructions and Interface Circuit Control-Machine manual TNC 155 A/ TNC 155 P)</p> <p>.Exceeding the range for the continuous position supervision determined by MP 57. (see Mounting Instructions and Interface Circuit Control-Machine manual TNC 155 A/ TNC 155 P)</p> <p>.Relationship between output voltage and traversed distance outside of the defined tolerance.</p> <p>.Defect in the pulse counting section (Control circuitry) after the transducer signal supervision</p>	<p>In the Case of Gross Positioning Errors A/B/C/D the fault could lie with any element in the closed loop servo system, ie Control hardware (CLP-Graphics Brd.), " " (Analogue Brd.), servo amplifier (offset voltages), " " (gain too low), motor, tacho, measuring system, external forces acting on drives, inappropriate MP values programmed.</p>
		<p>Aid:</p> <ol style="list-style-type: none"> 1. Program MP 54 (acceleration) as small as possible. 2. Adjust rapid traverse (as small a trailing error as possible). 3. Gradually increase MP 54. <p>If this does not help: fault in the Control hardware (closed loop) or in the machine</p>

Kundendienst

VDU Display (flashing)	Fault cause	Possible fault location
GROSS POSITIONING ERROR B	.The Control-calculated analogue output voltage (implied by trailing error) is greater than 10 V	see above
GROSS POSITIONING ERROR C	.The analogue output voltage actually necessary to obtain a desired speed deviates from the expected, calculated voltage, by more than the voltage programmed in MP 234	see above
GROSS POSITIONING ERROR D	.The actual position at standstill deviates from the intended position by more than the distance programmed in MP 169	see above
TNC-OPERATING TEMP. EXCEEDED	.Ambient temperature inside the TNC has exceeded +65°C .Fault in the temperature supervision	Ambient temperature of Control Analogue Board

Kundendienst

CRT display (flashing)	Fault origin	Possible fault location
ERROR IN PLC PROGRAM	Fault with safety-related marker (see PLC-Description manual TNC 155 A/TNC 155 P pages 36....40)	
" " " " A	Start Key Error with safety-related marker	PLC Program, Main Processor Board
" " " " B	Rapid traverse key	" " " " "
" " " " C	Direction latch key	" " " " "
" " " " D	Feed release	" " " " "
" " " " E	Start PLC positioning X-axis	" " " " "
" " " " F	Start PLC positioning Y-axis	" " " " "
" " " " G	Start PLC positioning Z-axis	" " " " "
" " " " H	Start PLC positioning IV-axis	" " " " "
" " " " I	Direction key X+	" " " " "
" " " " J	Direction key X-	" " " " "
" " " " K	Direction key Y+	" " " " "
" " " " L	Direction key Y-	" " " " "
" " " " M	Direction key Z+	" " " " "
" " " " N	Direction key Z-	" " " " "
" " " " O	Direction key IV+	" " " " "
" " " " P	Direction key IV-	" " " " "
" " " " Q	Undefined macro called-up via PLC marker	" " " " "

Kundendienst

VDU Display (flashing)	Fault cause	Possible fault location
TNC-ELECTRONICS DEFECTIVE 0	False CRC CHECK-SUM* of machine-related data excluding machine parameters. (Baud rate, limitation, preset etc)	Main Processor/Memory Board
" " " 1	False CRC CHECK-SUM* (machine parameters)	Memory/Main Processor Board
" " " 2	False CRC CHECK-SUM* (user memory)	Memory/Main Processor Board
" " " 3	Integrated Test Program execution incomplete	Main Processor/Memory Board
" " " A	Software error Main Processor	Main Processor Board
" " " B	Software error CLP Processor	CLP-Graphics Board
" " " C	MID interrupt** CLP Processor/Main Processor Board	
" " " D	CLP Processor instruction stack overflow	CLP-Graphics Board
" " " E	False instruction: Main Processor → CLP Processor	CLP-Graphics/Main Processor Board
" " " F	False instruction (display mode): Main Processor → CLP Processor	CLP-Graphics/Main Processor Board
" " " G	CLP Processor RAM	CLP-Graphics Board
" " " H	Overflow interrupt	Main Processor Board
" " " I	MID interrupt Main Processor	Main Processor Board
" " " J	Equipped with incorrect language version	Main Processor Board
" " " K	RAM E000...FFFF Main Processor	Main Processor Board

* CRC = Cyclic Redundancy Check

** MID = Macro Instruction Detection

Kundendienst

VDU Display (flashing)		Fault cause	Possible fault location	
CHECK-SUM ERROR	XX00	CRC CHECK-SUM error with EPROM 4 XX = correct CHECK-SUM value 00 = code for faulty EPROMs	Main Processor Board	
"	"	XX02	CRC CHECK-SUM error with EPROM 5	Main Processor Board
"	"	XX04	" " " " with EPROM 6,7,8	Main Processor Board
"	"	XX0A	" " " " with EPROM 9	Main Processor Board (PLC program)
"	"	XX0B	" " " " with EPROM 9	Main Processor Board (PLC dialogue)
"	"	XX0C	" " " " with EPROM A	Main Processor Board
"	"	XX10	" " " " with EPROM B,C,D	Memory Board
"	"	XX17	" " " " with EPROM E	Memory Board
"	"	XX18	" " " " with EPROM F	Memory Board
"	"	XX1A	" " " " with EPROM G	Memory Board
"	"	XX1C	" " " " with EPROM H,K	Memory Board
"	"	XX1F	" " " " with EPROM K	Memory Board
"	"	XX20	" " " " with EPROM 2	CLP-Graphics Board
"	"	XX21	CRC CHECK-SUM error in RAM area on the CLP-Graphics Board in which a part of the operating program is stored	CLP-Graphics Board
"	"	XX22	CRC CHECK-SUM error with EPROM 3	CLP-Graphics Board (export version)
"	"	XX23	CRC CHECK-SUM error in the RAM area on the CLP-Graphics Board where a part of the oper- ating program is stored	CLP-Graphics Board (export version)
"	"	XXFF	CRC CHECK-SUM error with PLC-RAM PLC Marker 2815 is set	Main Processor Board

2.2.3 Testing of the VDU and the associated drive circuitry

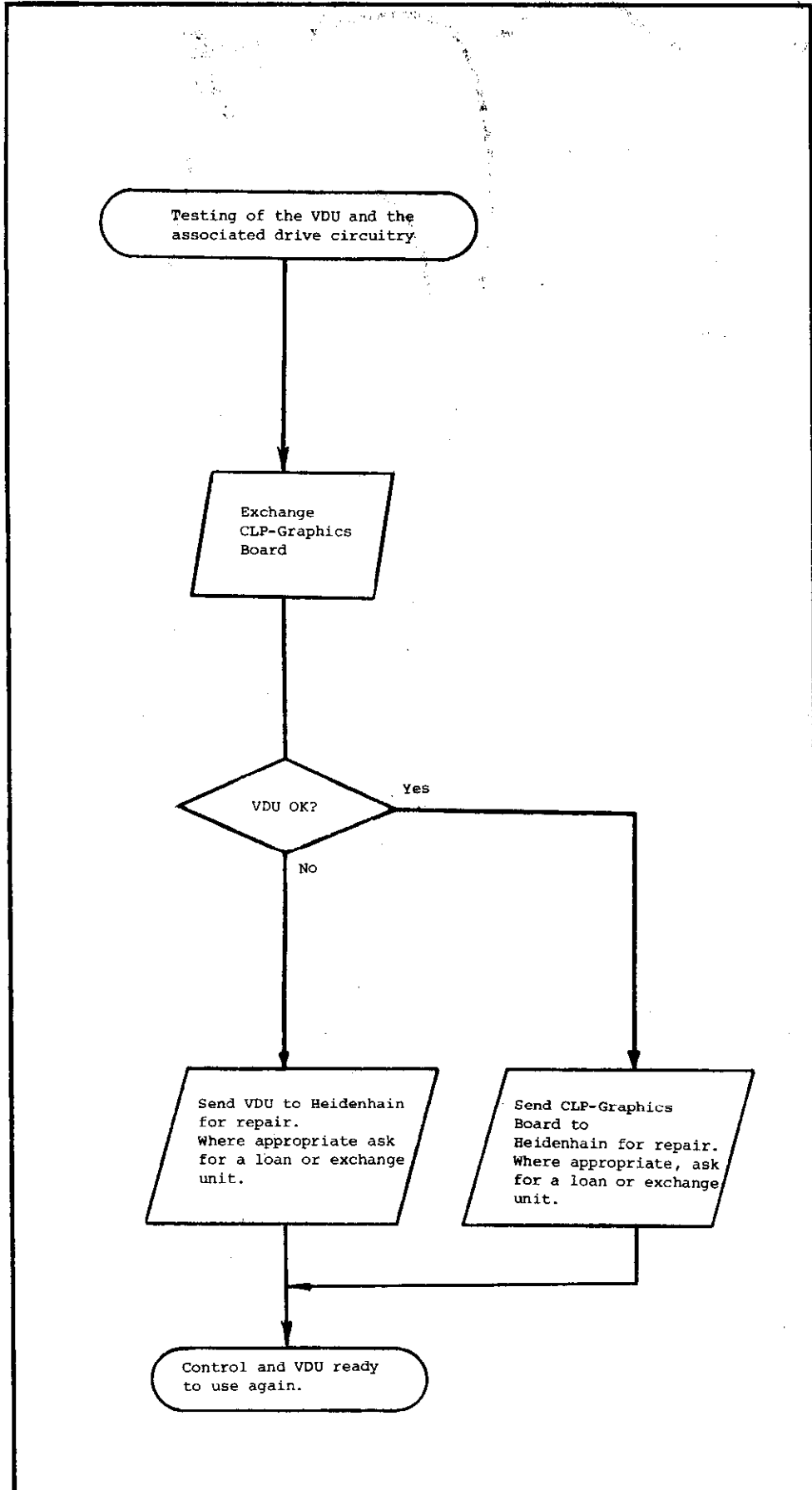

Kundendienst

2.2.4 Testing of the mains supply and the Power Supply Unit

The procedure for testing the Power Supply Unit is shown in the flow diagram on page 16. As part of that procedure, it may be necessary to test the voltages at various points on the Power Supply Board. The diagram opposite and the table below show the locations of the test points (solder terminals) on the (new) Power Supply Board 230 802, and the respective nominal and "actual" test voltages under load. Early TNC 155 Controls may be fitted with Power Supply Board 227 601 .. (as used in the TNC 145/150/151). The test data for this PSU is given on page 15.1.

Plug and solder-terminal signal designation

Plug pin	Cable colour	Solder terminal test points	Voltage/Signal (Nominal)	Test values (V) under load
1	black	23/24	0V TTL	
2	brown	17	+12 Processor supply	12,0 + 0,5 at 100 ohms
3	red	21/22	+5V TTL	5,2 + 0,1 at 1,5 ohms
4	grey	20	-15V Switching reg.	-15,0 + 1,5 at 150 ohms
5	-	-	n.c.	
6	green	16	+15V Analogue Board	15,5 + 0,1 at 50 ohms
7	-	-	n.c.	
8	-	-	n.c.	
9	green/white	13/8	Reset	
10	-	-	n.c.	
11	-	-	n.c.	
12	-	-	n.c.	
-	-	1	21V ~ } Mains transf. sec. voltage	
-	-	2	21V ~ } Mains transf. sec. voltage	
-	-	3	21V ~ } Mains transf. sec. voltage	
-	-	4	21V ~ } Mains transf. sec. voltage	
*	-	5	0V	
*	-	6	2,1V ~ } Mains transf. sec. voltage	
*	-	7	2,1V ~ } Mains transf. sec. voltage	
-	-	9,10,11,12	no connection	

* not used with TNC 155

Signal designations for the plug and test points.

Test Data Power Supply (New Board 230 802 ..)

The voltages are to be measured under load (with boards or load unit connected).

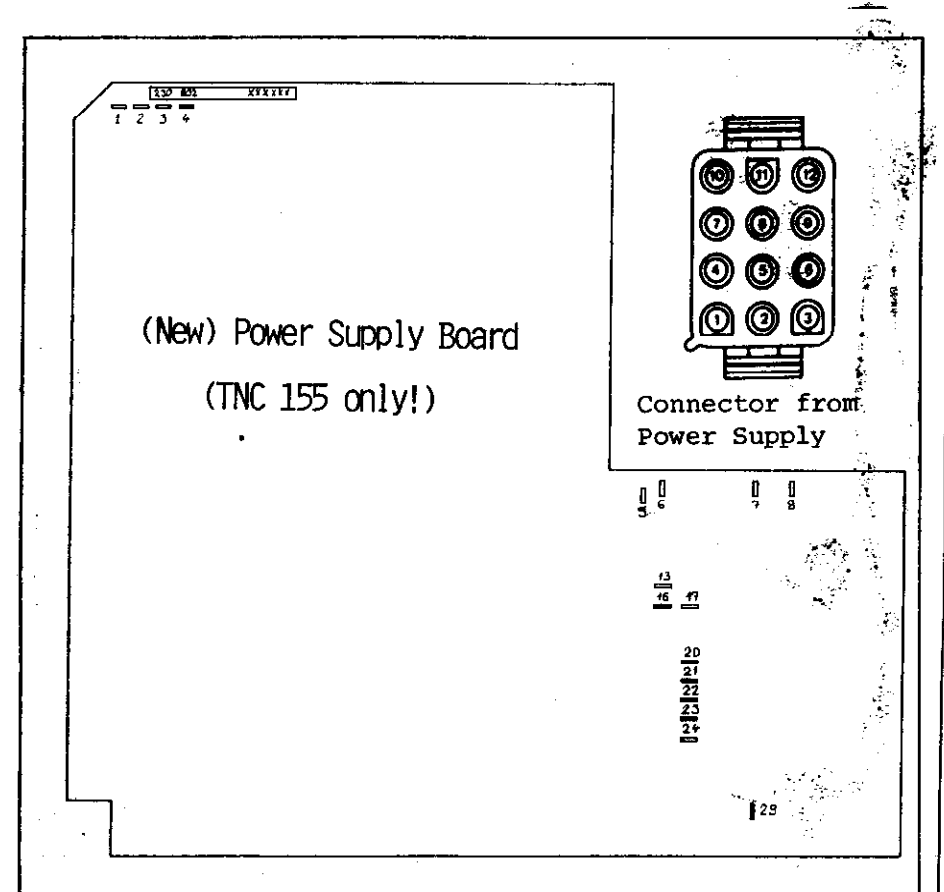

Kundendienst

Test Data Power Supply (Old Board 227 601 ..)

The voltages are to be measured under load
 (with board or load unit connected).

Plug and solder-terminal signal designation

Plug pin	Cable colour	Solder terminal test points	Voltage/Signal (Nominal)	Test values (V) under load		
1	black	23/24	0V TTL			
2	brown	17	+12 Processor supply	12,0	+ 0,5	at 0,15A
3	red	21/22	+5V TTL	5,16	+ 0,08	at 3,5A
4	grey	20	-15V Switching reg.	-14,9	+ 0,6	at 0,1A
* 5	blue	27/28	0V Display Unit			
6	green	16	+15V Analogue Board	15,0	+ 0,6	at 0,3A
7	yellow	19	+45V Switching reg.	45,2	+ 1,5	at 0,06A
* 8	white	25/26	+11V Display Unit	11,2	+ 0,25	at 1,4A
9	green/white	13/8	Reset			
* 10	yellow/white	18	+22V Display	21,6	+ 0,8	at 0,01A
* 11	brown/white	15	4,2V ~ Heater	4,2	+ 0,2	at 0,17A
* 12	brown/white	14				
-	-	1	21V ~ Mains transf.			
-	-	2	sec. voltage			
-	-	3	21V ~ Mains transf.			
-	-	4	sec. voltage			
*	-	5	0V			
*	-	6	2,1V ~ Mains transf.			
*	-	7	sec. voltage			
-	-	9,10,11,12	no connection			

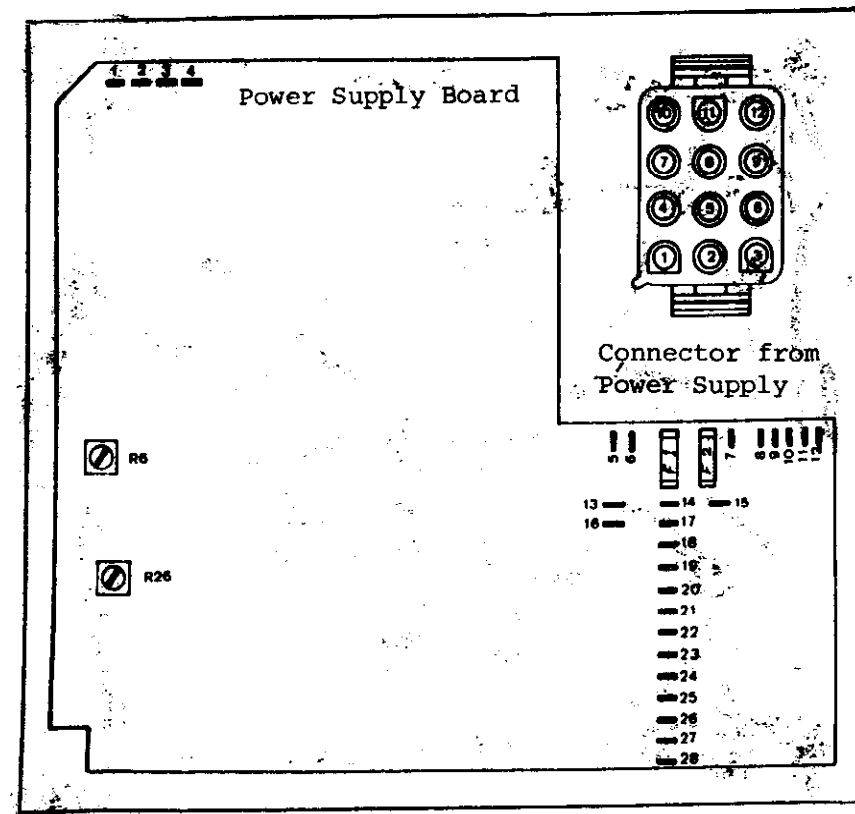

The fuses 1 and 2 are not used in the TNC 155

* not used with TNC 155

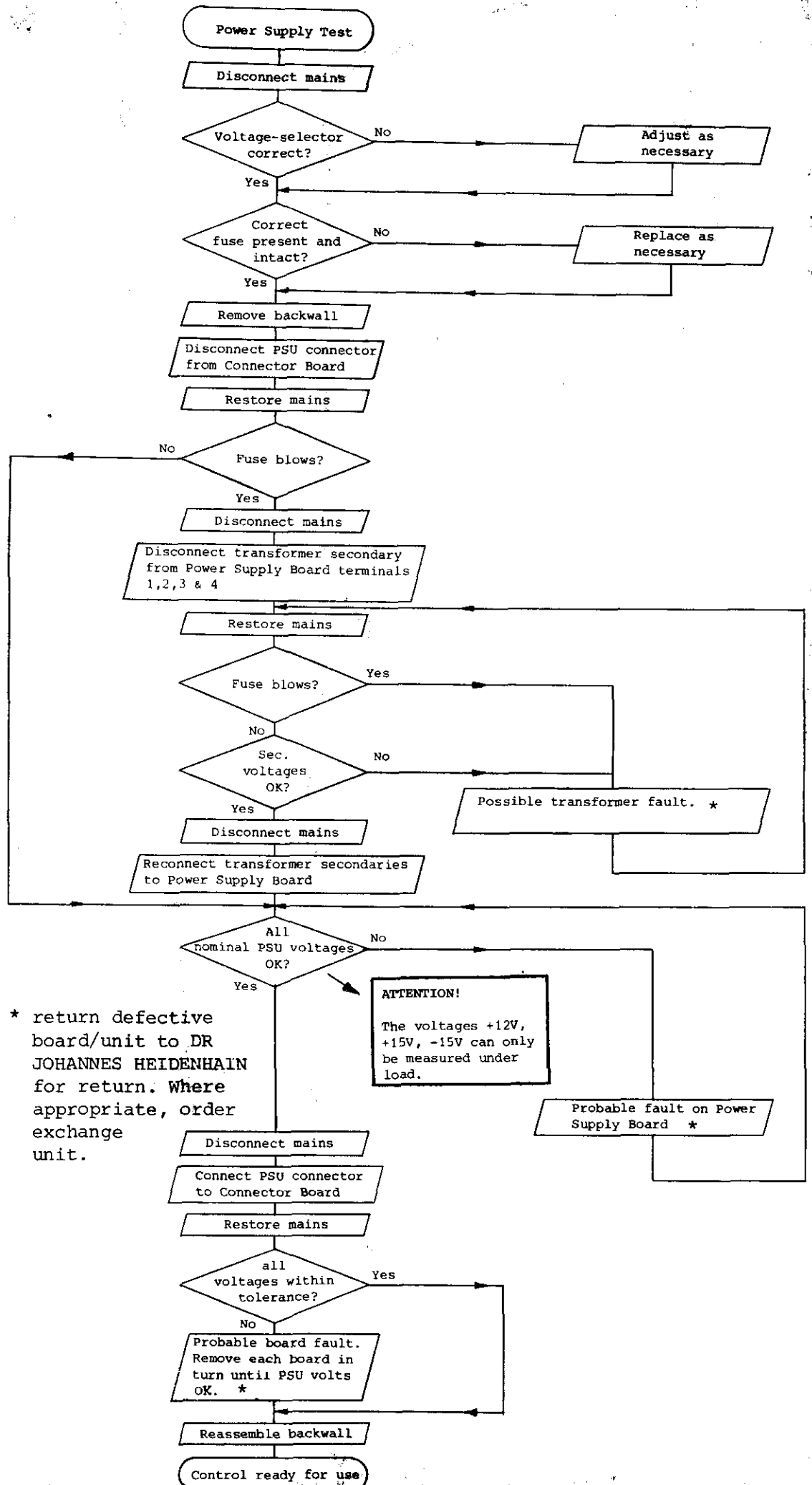

Procedure for testing the Power Supply Unit

* return defective board/unit to DR JOHANNES HEIDENHAIN for return. Where appropriate, order exchange unit.

ATTENTION!
 The voltages +12V, +15V, -15V can only be measured under load.

Kundendienst

2.2.5 Testing of the measuring systems and wiring

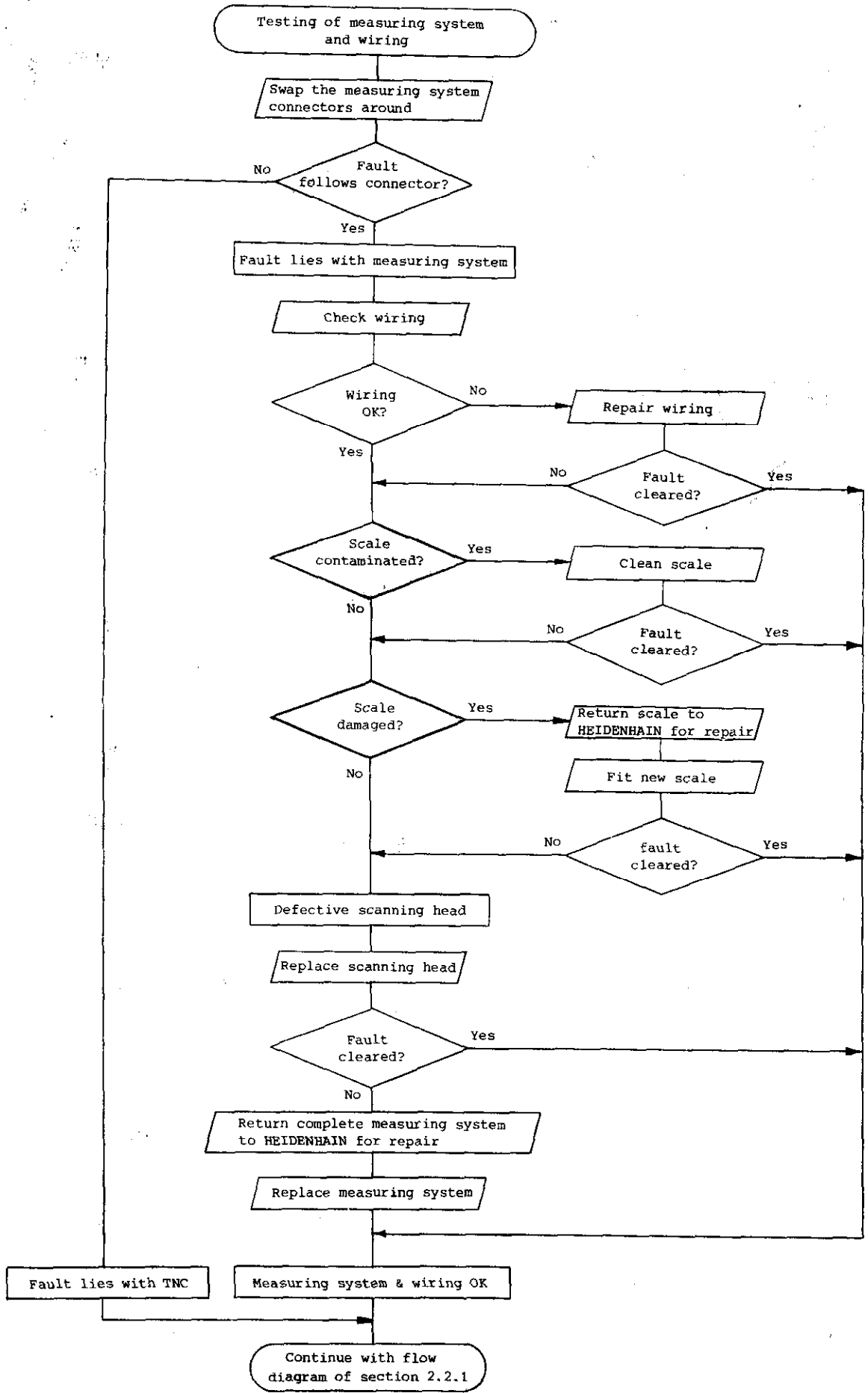



Kundendienst

2.2.6 Burn-In Test

In some cases, inspite of there being definite fault conditions on the control, error messages may not be displayed on the VDU. However, the Control's electronics can be tested with the help of the Burn-In test program.

This test program is a means of dynamically testing the Control's hardware and can be used not only for duration testing but also for fault diagnosis.

The test program is stored on a digital cassette and can be loaded into the Control via magnetic tape units ME 101 B/102 B or ME 101 C/102 C.

The test program cannot be loaded into the Control if the flashing error message: "TNC ELECTRONICS DEFECTIVE" is present on the VDU. In this case, the faulty board must be determined by exchanging each board in turn until the fault is eliminated. However, before exchanging any board, it is advisable to check the output voltage from the Power Supply Unit (see section 2.2.4).

To run the Burn-In test program it is necessary to have a set of Burn-In Test Adapters.

Figs. 2 to 5 show pictorial and schematic representations of each individual adapter.

Depending on the type of Control, (TNC with either a standard SE interface or with an external PLC I/O Board) the appropriate adapters must be connected as shown in fig. 1.

It is important to have the correct test program for the type of Control and for the Control's current NC Software issue. The test programs are listed on page 20. The type of Control can be determined from the identification number of the unit; the issue of the NC Software can be determined from the NC Software issue number. Both these numbers are found on the type-plate on the rear of the Control.

Application of the Burn-In Test

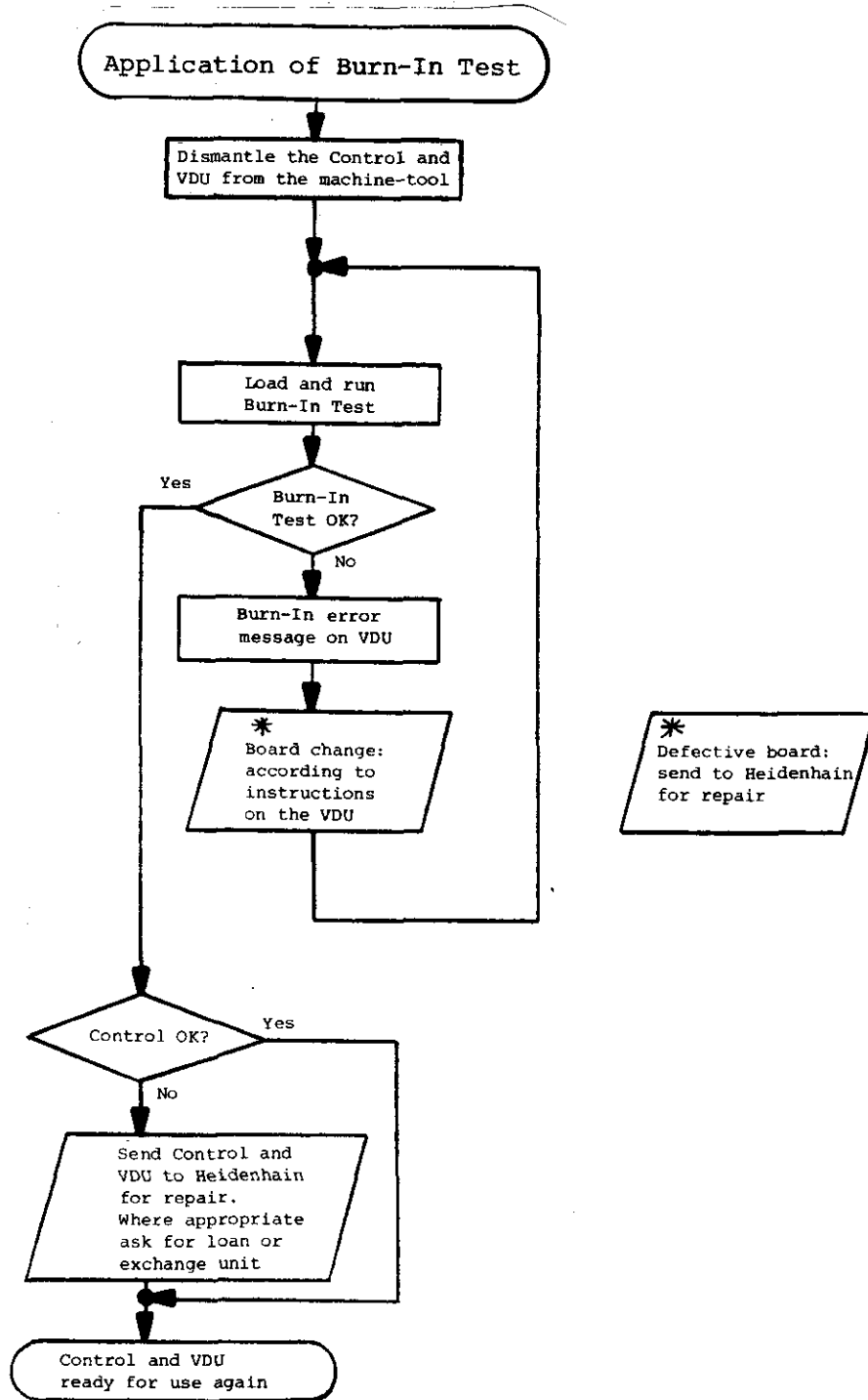

Kundendienst

Burn-In Test Programs for TNC 155 A

on the Philips miniature cassette

Control Type	Control Id. No.	From NC Software issue	Test dialogue	Test Prog. Id. No.
TNC 155 A	225 028 99 01	D	212 986 01
TNC 155 A	225 028 99 01	GB	212 987 01
TNC 155 A	225 028 99 06	D	212 986 02
TNC 155 A	225 028 99 06	GB	212 987 02

Burn-In Test Programs for TNC 155 P

on the Philips miniature cassette

Control Type	Control Id. No.	From NC Software issue	Test dialogue	Test Prog. Id. No.
TNC 155 P	225 030 99 01	D	212 988 01
TNC 155 P	225 030 99 01	GB	212 989 01
TNC 155 P	225 030 99 06	D	212 988 02
TNC 155 P	225 030 99 06	GB	212 989 02

Kundendienst

Fig. 1 Interconnections of Burn-In Adapters and TNC 155

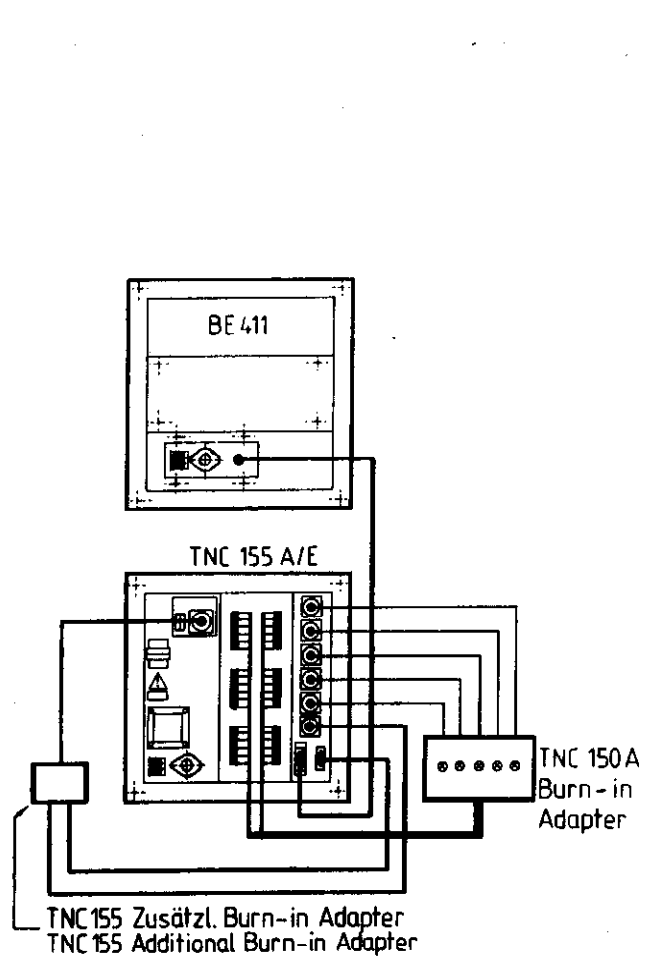

a) TNC 155 A/E

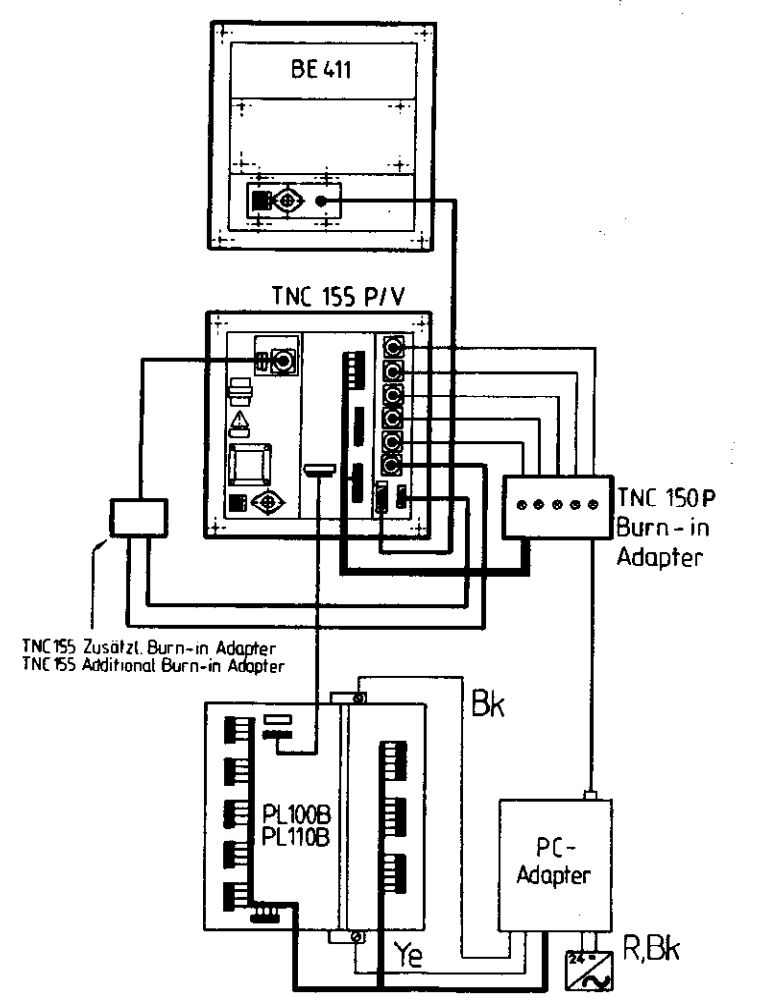

b) TNC 155 P/V

Kundendienst

Fig. 2 TNC 150 A Burn-In Adapter (Id. No. 224 874 ZY)

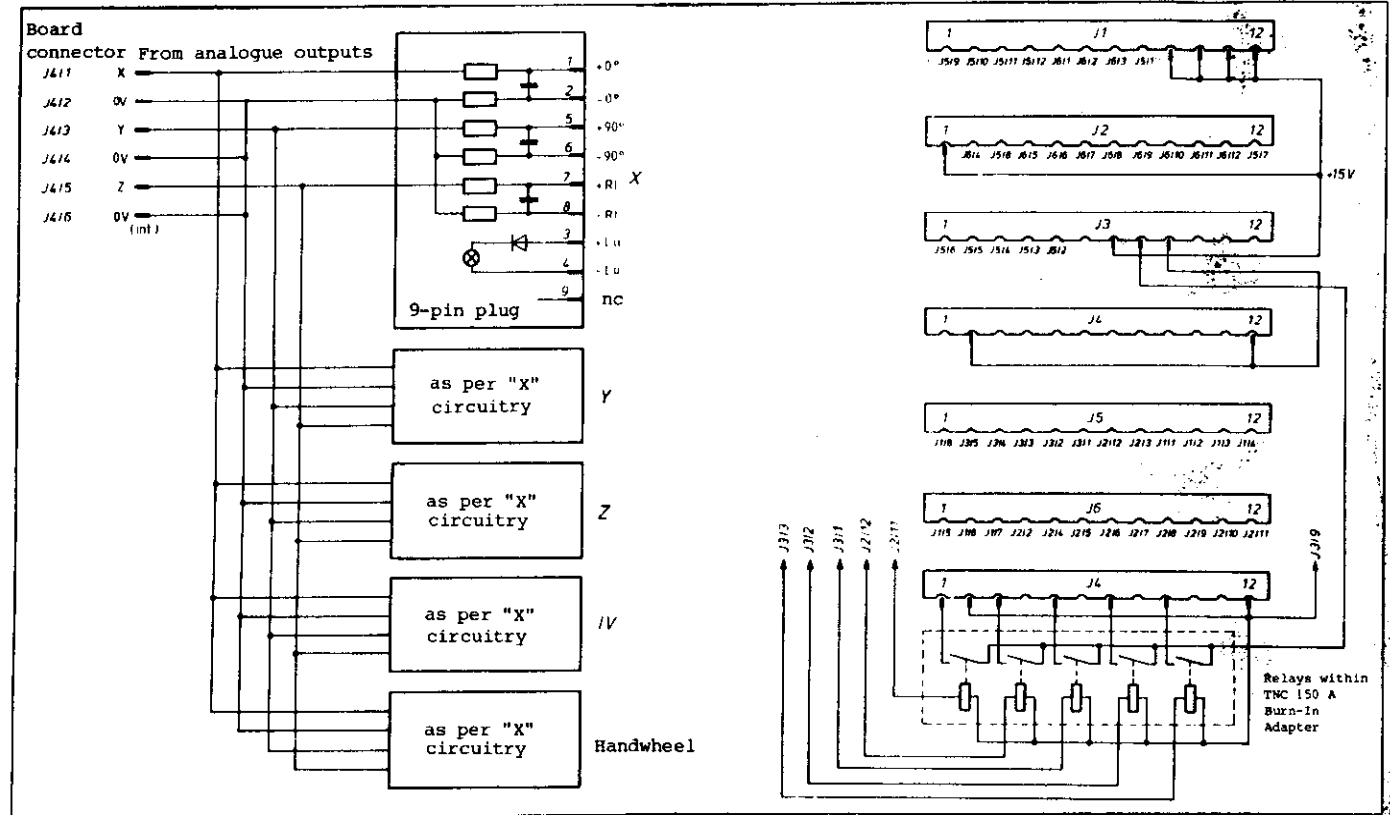
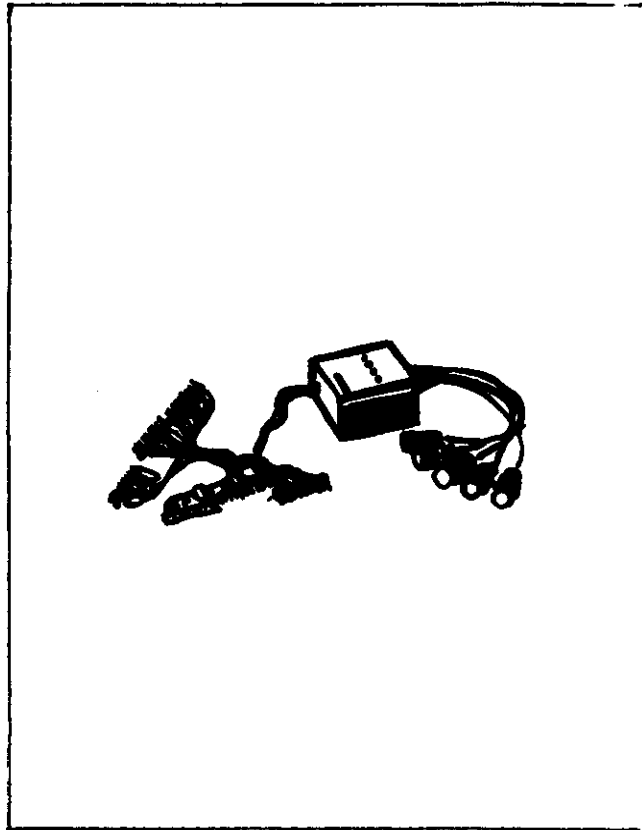

Schematic of interconnections created by connecting the TNC 150 A Burn-In Adapter to the Control.

Kundendienst

Fig. 3 TNC 150 P Burn-In Adapter (Id. No. 224 875 ZY)

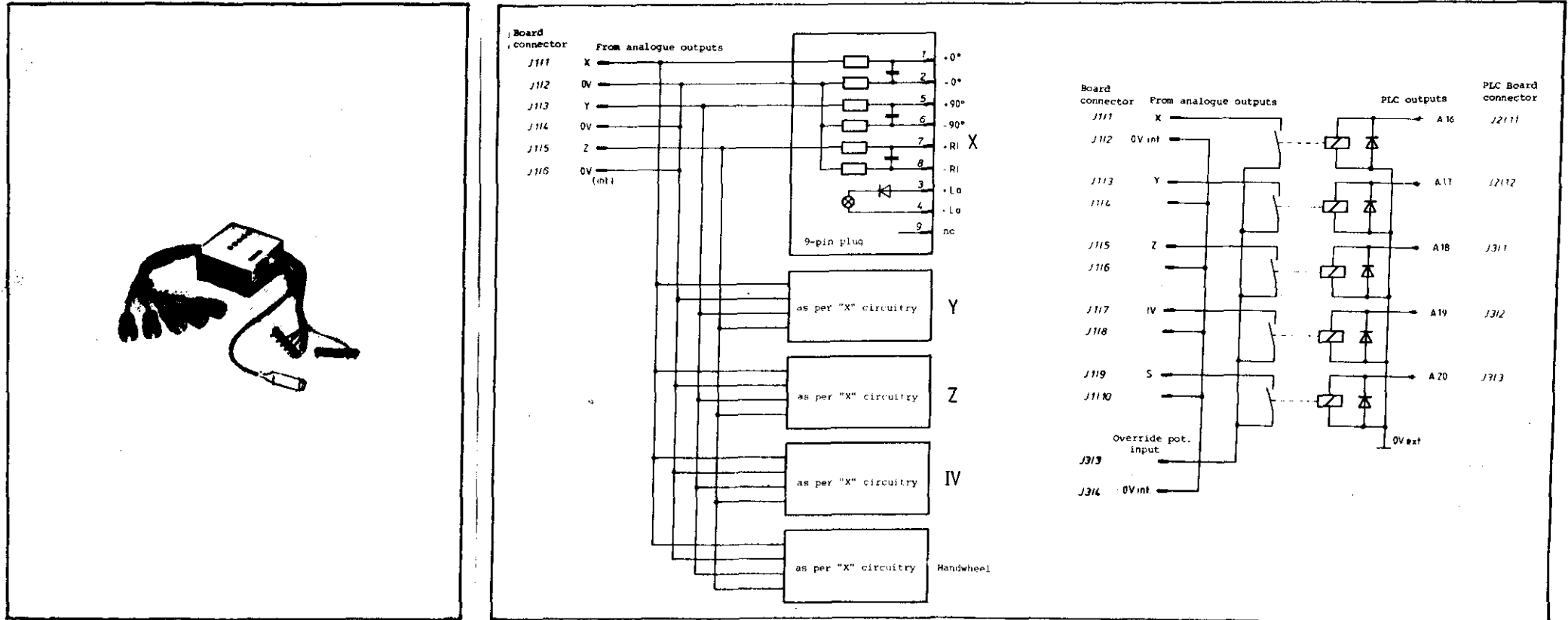

Schematic of interconnections created by connecting the TNC 150 P Burn-In Adapter to the Control.

Kundendienst

Fig. 4 PC Adapter (Id. No. 224 873 ZY)

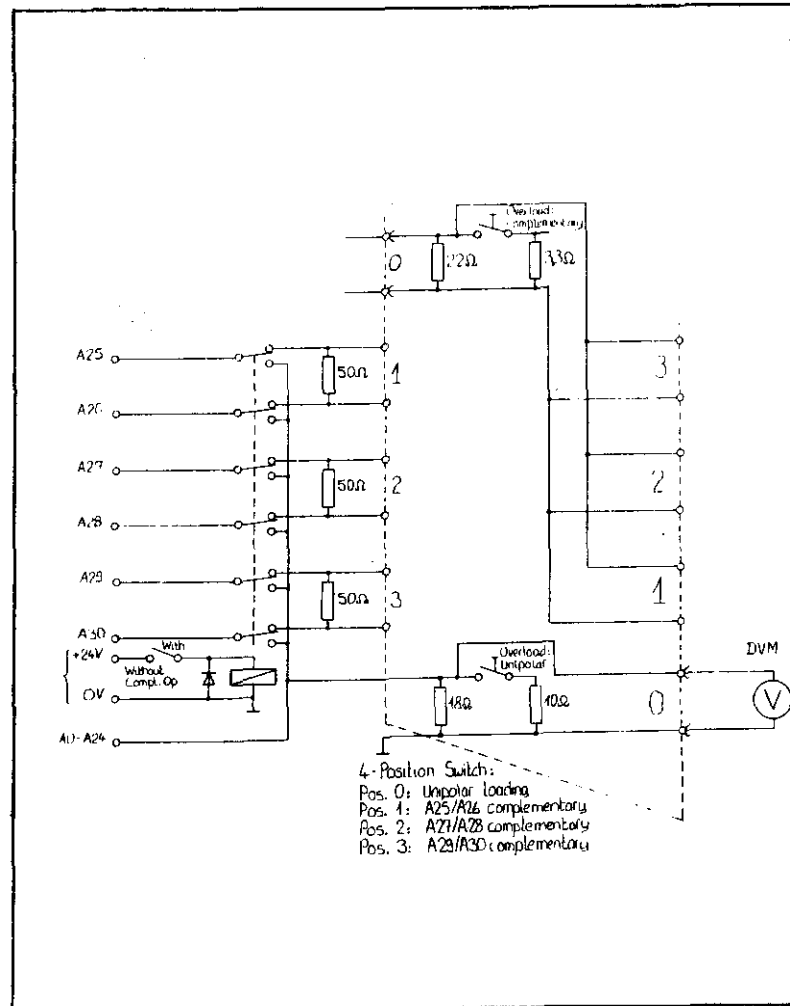
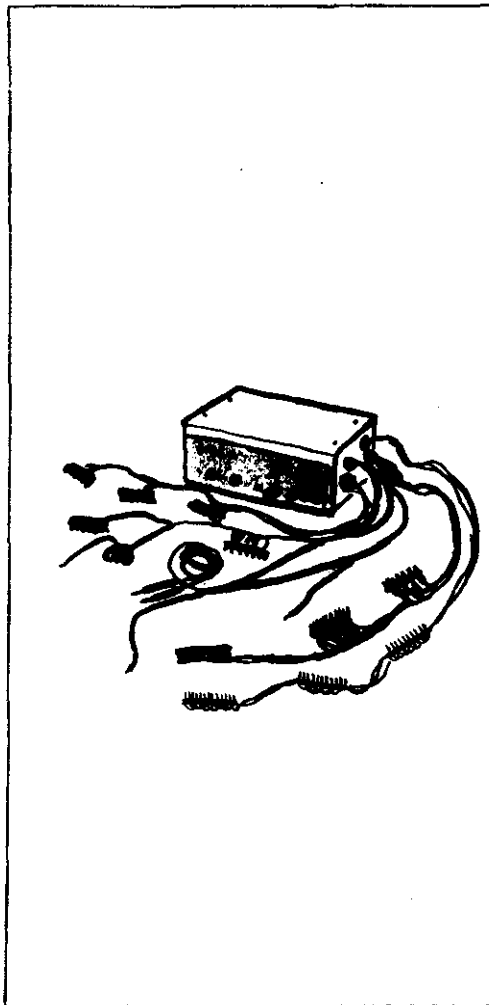

Internal circuitry schematic:
 Additional circuitry for overload
 facility

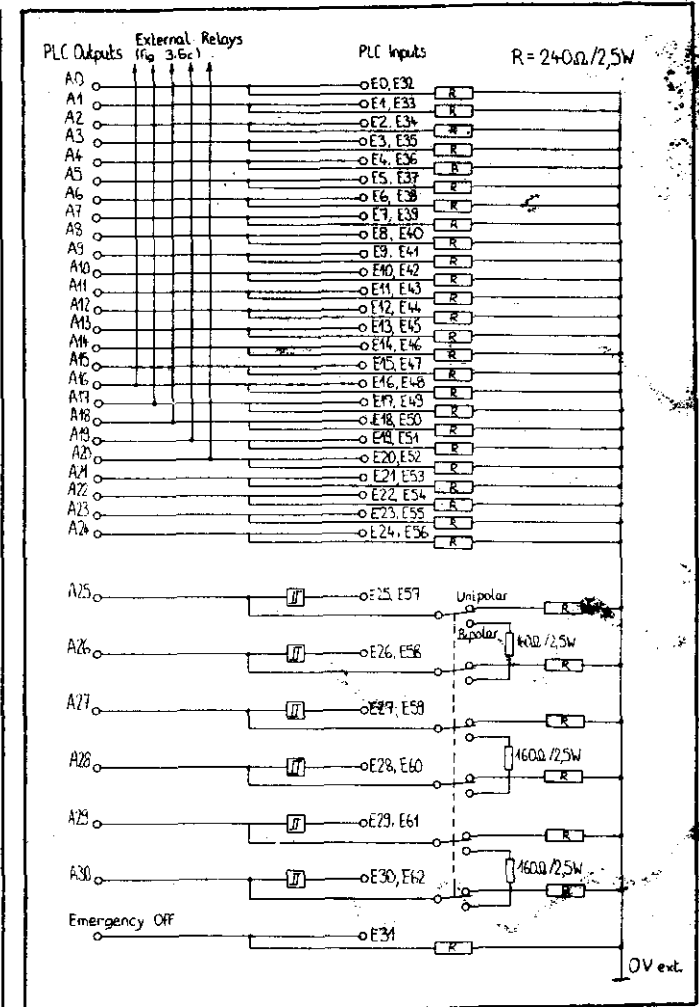

Internal circuitry schematic:
 Standard circuitry, with unipolar/
 bipolar switch-over.

Kundendienst

Fig. 5 TNC 155 Additional Burn-In Adapter (Id. No. 228 881 ZY)

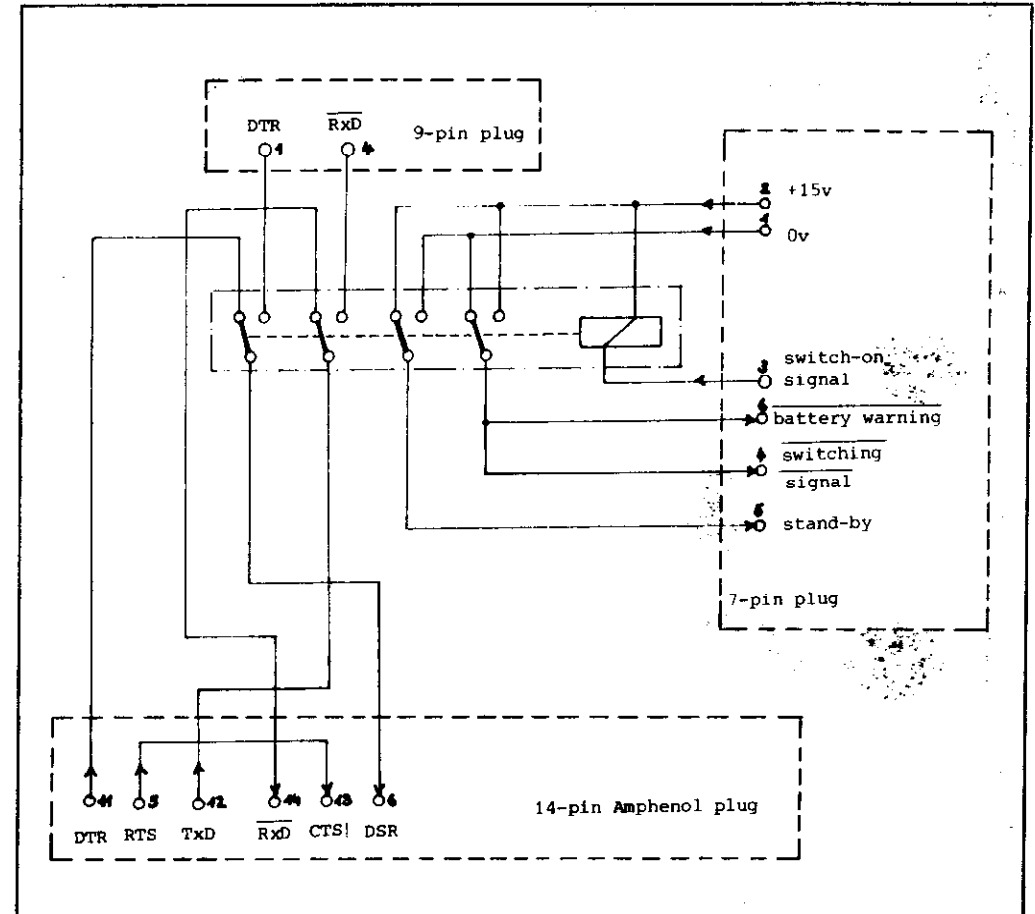
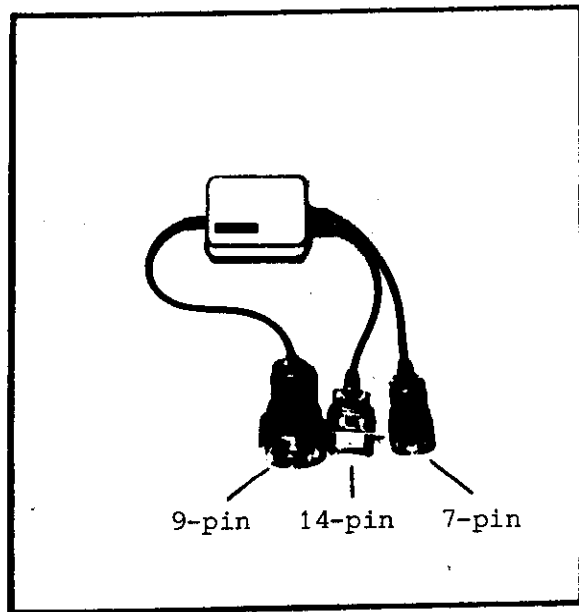

Internal connections.

Kundendienst

Loading the Burn-In test program

(Burn-In test program not already loaded)

1. Connect the Magnetic Tape Cassette Unit (ME 101/102) to the V.24 socket on the rear of the Control.
2. Prepare the ME unit to down-load the test program to the Control by inserting the appropriate program cassette (see list, page 20) and pressing the following buttons:

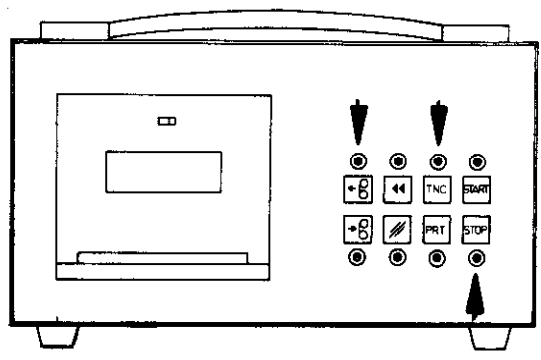

Fig. 6 Initialization of ME unit

3. Control must now be prepared:
 After applying power to the Control, it automatically carries out a memory test. During this time the dialogue

"MEMORY TEST"

will be displayed on the VDU.

Upon completion of this test, the dialogue will be replaced by

"POWER INTERRUPTED".

The necessary code number for reading in the Burn-In test program is entered by pressing the following keys:

- as often as necessary to obtain the display:

"CODE NUMBER =", and then:

(Errors in entering these numbers can be corrected by pressing).

4. The data transfer is then initiated by pressing:



During the loading of the Burn-In test program from the ME unit, the following dialogue will be displayed:

"POWER INTERRUPTED
 EXTERNAL DATA INPUT"

If necessary, the ME unit will first rewind the cassette tape before transmitting the data, blockwise, to the Control. Any user-programs already loaded/programmed into the Control will be **unaffected** by loading the Burn-In test program.

5. The Burn-In test program occupies both tracks of the cassette tape. Consequently, when all the data from the first track has been transferred, the following dialogue will be displayed:

"EXCHANGE CASSETTE - ME START
 EXTERNAL DATA INPUT"

To complete the data transfer, turn over the cassette and press the START button on the ME unit. The VDU will again display the dialogue.

Kundendienst

"POWER INTERRUPTED
 EXTERNAL DATA INPUT"

- After completion of a successful data transfer, the ME unit will rewind the cassette and the VDU will display the question

"EXTERNAL UNIT CONNECTED ?"

Any other display implies either a transmission error or an incorrect/faulty test program cassette.

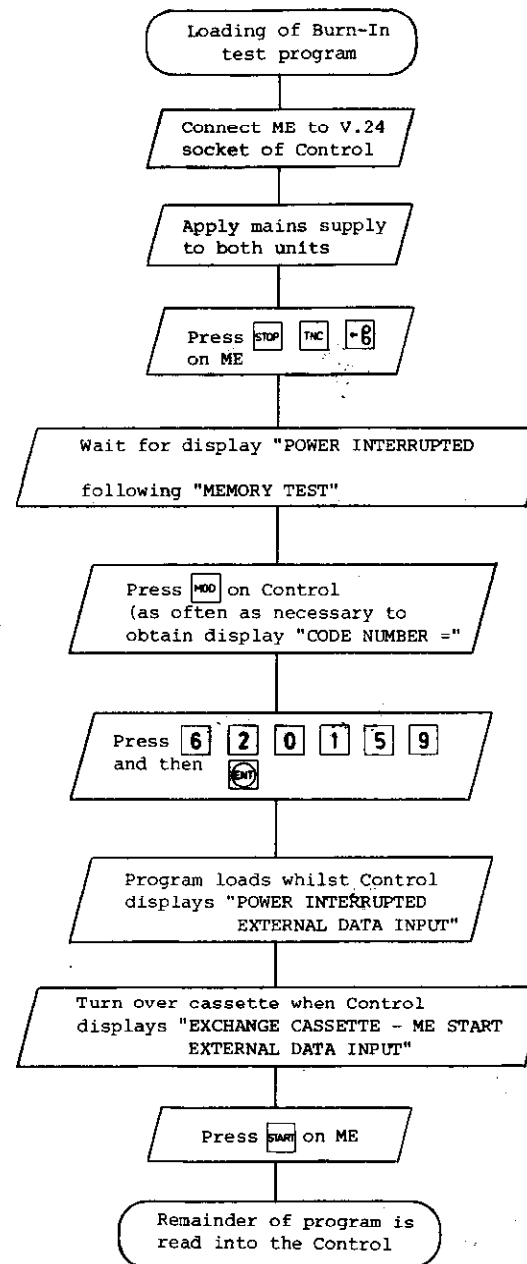

Fig. 7 Loading and Initialization of Burn-In Test Program

Kundendienst

Re-initialization of a previously loaded Burn-In test program

The possibility exists that the Burn-In test program has been loaded and then the power removed. In this situation the buffer batteries will maintain the program in memory until the mains is restored.

It is also possible that the system has been warm-booted, during the execution of the Burn-In test, by pressing



Under both of these circumstances the following procedure is to be followed in order to restart the Burn-In test program:

The Control will automatically carry out a memory check. This test takes approx. 17 sec, during which time the dialogue

"MEMORY TEST"

will be displayed on the VDU.

Upon completion of this test, the dialogue will be replaced by

"PRESS NOENT KEY"

IMPORTANT

Only press the key



if you wish to erase the Burn-In test program and return to the normal operating system.

To restart the Burn-In test program press



The following dialogue will then be displayed:

"EXTERNAL UNIT CONNECTED ?"

Any other display implies an error in the stored test program and the program must be reloaded from the cassette.

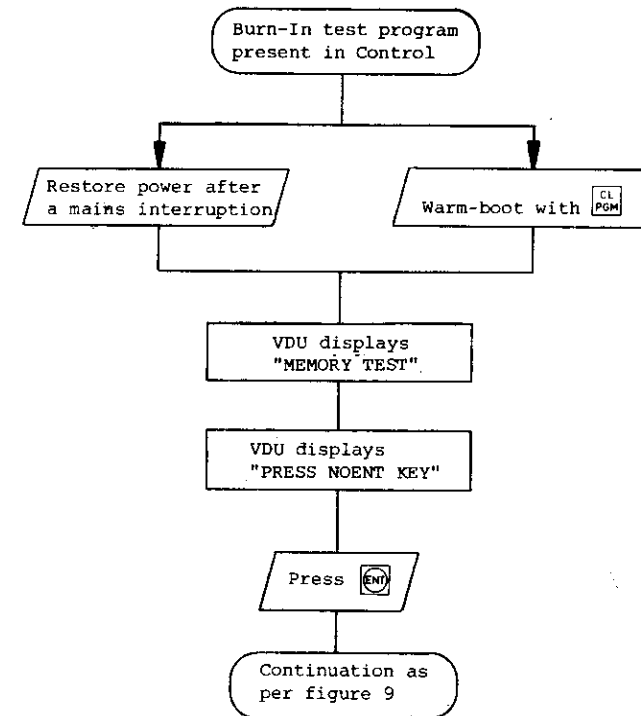

Fig. 8 Re-initialization of a previously loaded Burn-In test program

Kundendienst

Continuation of the Burn-In test initialization

The remainder of the initialization procedure must be described in conjunction with the flow diagram of figure 9, page 31

1. Beginning with the display

"EXTERNAL UNIT CONNECTED ?"

which refers to the use of an external test computer, the operator must respond by pressing

NO
 ENT

2. A check is now automatically carried out, to ensure that the test program data has not been corrupted in any way. If an error is detected, the display

"REREAD-IN PROGRAM XXXX
 CHECK SUM ERROR"

will appear on the VDU, and the test program must be reloaded from the ME unit.

3. If the keyboard test has not already been carried out (eg. prior to a mains interruption) the option of carrying out this test will now be displayed:

"JUMP OVER KEYBOARD TEST ?"

The keyboard test can be skipped by pressing the key

ENT

Any other key will cause the test to be carried out, in which case the following display will appear on the VDU:

```

. . . . . E
. . . . . E
. . . . . E
. . . . E
. . . . . E

```

The lines of dots represent the individual keys in each of the four keying fields. The keys must now be pressed once each, in a defined sequence, in order that the Control can check that each key is making contact and delivering the correct code to the keyboard interface.

The keying sequence is as follows:

- a) top right set of 20 keys
- b) top left set of 10 keys
- c) middle left set of 20 keys
- d) bottom left set of 4 keys
- e) bottom right set of 10 keys

In each case, the sequence is from left to right, beginning with the top row.

For each correct key-push, the respective dot on the VDU will be replaced with a "*".

If an incorrect code is received, the keyboard test will start again from the beginning.

If the keyboard test has previously been carried out (eg before a power failure), the option of carrying out the test is not displayed. In this case, assuming no error message has been stored from a previous run, the program jumps into the sequential tests (see page 32).

4. If the keyboard test has previously been carried out, and an error message has been stored from an earlier run, this error message will be displayed and the program will wait for an interrupt (see point 7).

5. In the case of a Control designed for use with an external PLC I/O Board, the following text will appear on the VDU, following a successful keyboard test:

"0, 1, OR 2 PC-BOARD ?"

This refers to the number of external PLC I/O Boards connected to the Control during the test, and must be answered with the appropriate numeric key.

Kundendienst

6. The final step of the full initialization procedure is the calibration of the two potentiometers on the front panel of the Control. These must be adjusted to give the display:





"TEST INT.POT, BATTERY TRIGGER
 OVERRIDE POT ADJUST: 100
 SP. ROT. SPEED ADJUST: 100"

If necessary, the caps of the knobs must be removed, the securing screws slackened, and the knobs realigned and tightened in the 100% position.

7. At the beginning of the initialization procedure, interruptions of the program are inhibited. After completion of the initialization, interrupts are enabled to permit jumps, at any time, to various points in the test procedure. Once the interrupts have been enabled, the test program can be interrupted by pressing one of a number of keys. The keys:



for example, cause restarts at various points during the initialization routine, as shown in figs. 8 and 9.

	System re-boot
	"EXTERNAL UNIT CONNECTED ?"
	"JUMP OVER KEYBOARD TEST ?"
	"0, 1, OR 2 PC-BOARD ?"
	"TEST INT.POT, BATTERY TRIGGER OVERRIDE POT ADJUST: 100 SP. ROT. SPEED ADJUST: 100"

Other interrupts are also possible; these are described in the following section.

Kundendienst

Fig. 9 Complete initialization of the Burn-In test program

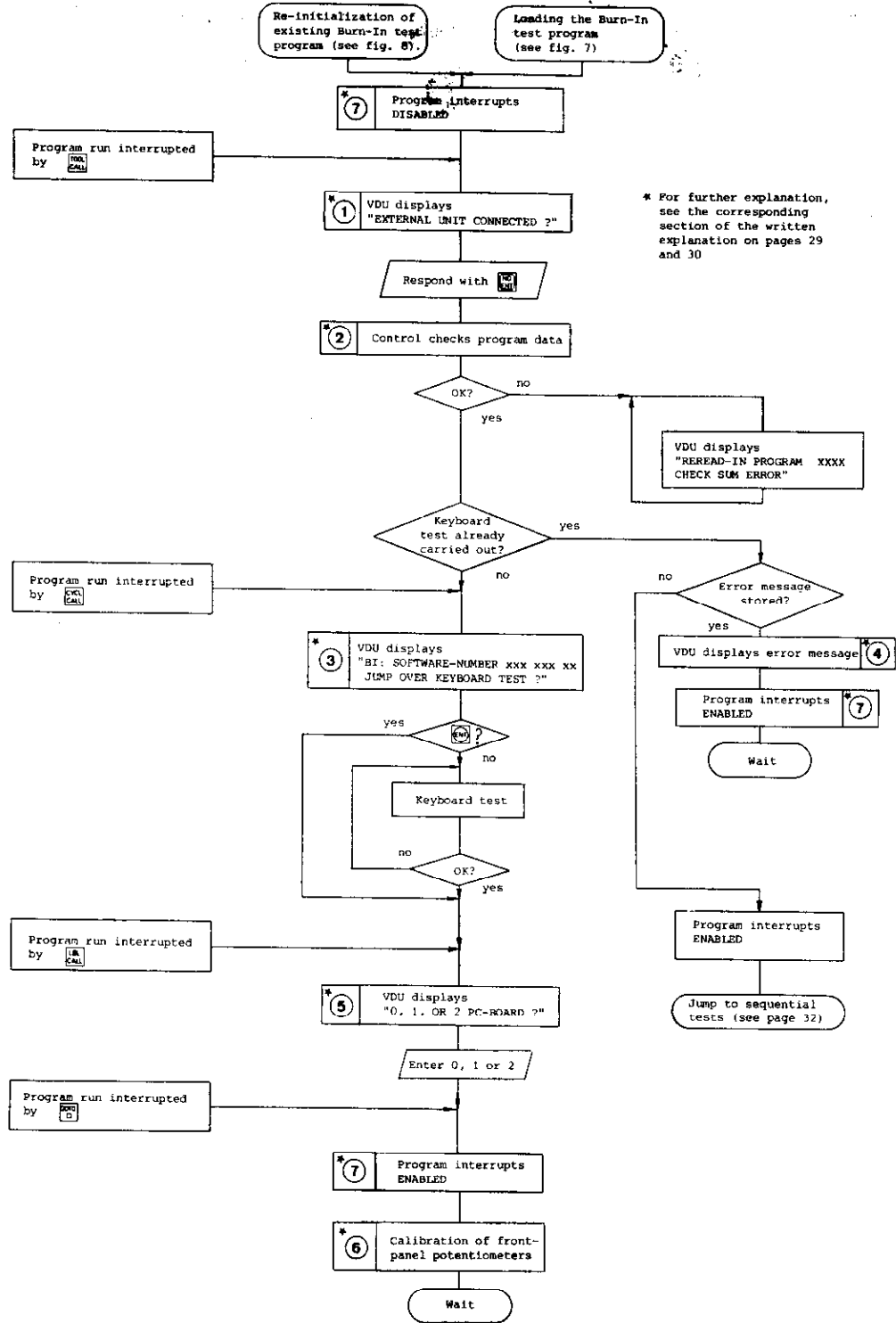

Kundendienst

Sequential (duration) tests

Before starting these tests, check that all test adapters are correctly connected, including the connection to the V.24 interface socket.

The following tests are included:

- a) Key .
 "TEST INT.POT, BATTERY TRIGGER"
 - Front panel potentiometers must be set to 100 ± 2%
- b) Key 0
 "EPROM TEST CPU"
 - The check-sums of all EPROMs accessible to the Main Processor Board CPU are checked.
- c) Key 1
 "RAMTEST CPU BOARD"
 - Checks the RAM on the Main Processor Board
- d) Key 2
 "RAMTEST MEMORY BOARD"
 - Checks the RAM on the Memory Board.
 This test must not be interrupted by a mains failure
- e) Key 3
 "TEST PC RAM"
 - Checks the RAM where the PLC data is held (markers, inputs, outputs, timers, counters etc).
- f) Key 4
 "TEST STATIC RAM
 CLP GRAPHICS BOARD"
- g) Key 5
 "TEST DYNAMIC RAM
 CLP GRAPHICS BOARD"

h) Key 6
 "TEST VIDEO RAM
 CLP GRAPHICS BOARD"

i) Key 7
 "PC INSTRUCT DECODER, ACCU-FF TEST"
 The circuitry used for decoding and carrying out the PLC instructions is tested.

j) Key 8
 "INPUT/OUTPUT TEST 1. PC BOARD" (only TNC 155 P)
 The PLC I/O Board outputs are resistively loaded and connected to the inputs by means of the PC Burn-In Adapter. Each output is connected to 2 inputs. By writing "1"s to the outputs, and checking the corresponding inputs, the Control is able to deduce whether a fault is on an input or an output. If a fault is detected (a "0" on an input) the input conditions are displayed on the VDU:

eg.:

"INPUT/OUTPUT TEST 1. PC BOARD
 OUTPUT (or input) FAILURE

INPUT	0	1	2	3	4	5	6	7	8	9	0	1	2	3	4	5	6	7	8	9
0	0	1	1	1	1	1	1	1	1	1	1	1	1	1	1	1	1	1	1	1
20	1	1	1	1	1	1	1	1	1	1	0	0	1	1	1	1	1	1	1	1
40	1	1	1	1	1	1	1	1	1	1	1	1	1	1	1	1	1	1	1	1
60	1	1	1	1																

BURN IN TIME: x,x HRS" always a zero

Input 31 is used to monitor a 20 ms monostable pulse generated on the Emergency Off output. If the duration of this pulses falls outside its tolerance limits, a fault condition will be displayed:
 eg.: "MONOFLOP TIME TOO SHORT 20MS"

This pulse can be generated manually by individual presses of the key + or, repetitively, by pressing the key twice in quick succession. This repetitive mode will be indicated by a "1" at input position 31 on the VDU.

Kundendienst

To aid in locating an I/O fault, each output can be driven individually. By pressing the key

(after a short delay) the VDU will display the input conditions when only output 0 is being driven high.

```
eg.: "INPUT 0 1 2 3 4 5 6 7 8 9 0 1 2 3 4 5 6 7 8 9
      0  1 0 0 0 0 0 0 0 0 0 0 0 0 0 0 0 0 0 0 0
      20 0 0 0 0 0 0 0 0 0 0 0 0 1 0 0 0 0 0 0 0
      40 0 0 0 0 0 0 0 0 0 0 0 0 0 0 0 0 0 0 0 0
      60 0 0 0 1
```

(always a "1")

OUTPUT A0, INPUTS E0, E32

Subsequent pressing of the key



allows successive outputs (in ascending order) to be driven high, or in descending order with the key

All outputs can be cleared with the key

k) Key
 "EXT. POT, ANALOG OUTPUT TEST"
 Five external relays within the TNC 150 A/P Burn-In Adapter, driven from outputs A16 - A20, are used to connect the analogue outputs X, Y, Z, IV, S, in turn, to the ext. pot. input (see figs. 2/3 pages 22/23). The test is made at three different voltages: 200mV, 5V, 9,5V

l) Key
 "TEST V24-INTERFACE"

m) Key
 "TEST 3D-SCANNER INTERFACE"
 - Checks the interface to the Touch Probe.

n) Key
 "TEST SERIAL HANDWHEEL INPUT"
 - Checks the interface to the HE 310 Handwheel Unit

o) Key
 "SUPERVISION CIRCUIT TEST"
 - checks the threshold values of the circuitry which monitors the measuring system inputs.

p) Key
 "TEST REFERENCE IMPULSE INPUT"
 - Checks the effect of a signal applied to the reference-pulse inputs.

q) Key
 "TEST TRANSDUCER INPUTS, EXE"
 - Checks the effect of signals applied to the measuring system inputs.

Starting the sequential tests

The test sequence can be started, or restarted at any point by pressing the appropriate key. (eg key to begin with the V.24 interface test.) All 17 keys associated with the sequential tests act as interrupts to the Burn-In test program.

Fault recognition

The detection of a fault will be displayed on the VDU. The test cycle will be halted and the Burn-In Time stops. If one or more faults arise during the execution of the Burn-In test program, the fault message associated with the first fault will be stored. The stored message can be retrieved at any time by pressing the key



This causes a system re-boot, as explained on page 30. All fault messages can be cleared with the key



This key also causes a restart of the sequential tests beginning with the test "TEST INT.POT, BATTERY TRIGGER".

Kundendienst

Individual test runs

Each of the individual, sequential tests can also be made to run cyclically. To do this, the test program must be interrupted with the key



The VDU will then display:

"1 = CYCLIC
2 = STOP AT FAULT"

Option 1 means that the test (still to be selected) will be run cyclically, regardless of whether a fault is detected. Option 2 means that the test will be run cyclically until such time as a fault is detected.

When one mode or the other has been selected, the VDU will display:

"SELECT TEST"

The desired test must then be selected with the appropriate key.

Another possible interrupt to the Burn-In test program is by means of the key



With this key the entire set of ASCII characters can be displayed on the VDU.

A graphics display consisting of a square grid with a circle in the centre can be displayed by pressing the key marked



Similarly the NC and PLC software numbers can be displayed by pressing the key



Calibration check of the Analogue Board ("TRIMMING ROUTINES")

Interrupting the Burn-In test program with the key



gains access to the calibration tests. Exit from these tests is only possible with the key



Within the calibration mode the following tests can be selected:

- Key **1** : Reference amplifier performance *
("TRANSMISSION BEHAVIOUR REF. AMP.")
- Key **2** : Analogue output voltage **
("ANALOG VOLTAGE OUTPUT")
- Key **3** : 32-step monotonic DAC *
("MONOTONY DAC; 32 STEPS")
- Key **4** : DAC performance *
("TRANSMISSION BEHAVIOUR DAC")
- Key **5** : +/- 10V analogue output **
("DAC + ANALOG OUTPUT +/- 10V")
- Key **6** : Linearity of analogue output *
("DAC + ANALOG OUTPUT LINEARITY")
- Key **7** : Battery voltage check **
("TEST BATTERY VOLTAGE")

() text in brackets appears on VDU

* these tests are not suitable for customer use.

** see following explanations:

Kundendienst

Key **2** : Analogue output voltage

The performance of the analogue output circuitry can be checked by connecting a DVM to each of the analogue outputs (eg X-axis: J1, pin1, w.s.t. pin 2) and selecting this test. Using the keys

X **Y** **Z** **IV**

voltage increments of 2,44mV, 24,4mV, 244mV and 2,44V respectively can be summed at each of the analogue outputs (X, Y, Z, IV, S).

eg.: if the X key is pushed 5 times, the Y key 3 times, and the

IV key once, the output voltage should read:

$$(5 \times 2,44 \text{ mV}) + (3 \times 24,4 \text{ mV}) + (1 \times 2,44 \text{ V}) = 2,5254 \text{ V}$$

The polarity of the output can be reversed using the key

+/-

The output can be cleared using the key

0

Key **5** : +/- 10V analogue output

The analogue outputs should generate their maximum output of +10V. The polarity can be reversed as in test 2.

Key **7** : Battery voltage check

A "1" will be displayed on the VDU if the battery voltage is adequate, otherwise a "0" is displayed.

Kundendienst

3. Exchange Information

Note: All inputs/outputs from the TNC 155 Control can only be connected to circuits which have voltages conforming to VDE S.73 §8.

Do not disconnect or connect plugs under power!

NC machines also need protection and installation safety as required for manually operated machines (e.g. EMERGENCY STOP). Their function should be checked during commissioning of the machine and of a new Control.

Before exchanging a Control the machine parameters should be noted or stored on magnetic tape!

Kundendienst

3.1 Exchanging Control Units

3.1.1 Procedure for exchanging the TNC 155 A/E Control.

1. Gain access to the rear of the Control.
2. Remove the mains supply.
3. Remove the connector box cover-plate from the rear of the Control.
4. Mark the measuring system plugs (X,Y,Z,IV, Electronic Handwheel) and remove them.
5. Disconnect the VDU from the Control.
6. Disconnect the Handwheel Unit from the Control (if present).
7. Disconnect any external data devices.
8. Disconnect connector strips J1-J6, using a screwdriver to prise the connectors apart (Do not unscrew individual wires).

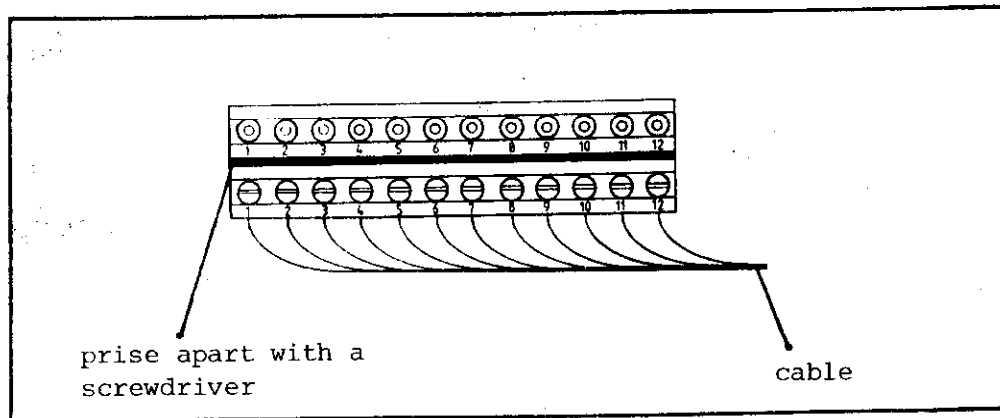

9. Remove the faulty Control, removing the fixing screws if not already removed in 1.
10. Install the new Control - check the voltage selector position.
11. Check the fuse-rating (see type-plate).
12. Reconnect all cables previously removed.
13. Obtain from the type-plate the Control's Id. No., NC and PLC Software Nos., and write them in the machine handbook.
14. Refit the connector box cover-plate.
15. Turn on the mains voltage.
16. Reprogram the machine parameters.
17. TNC is now ready to use.

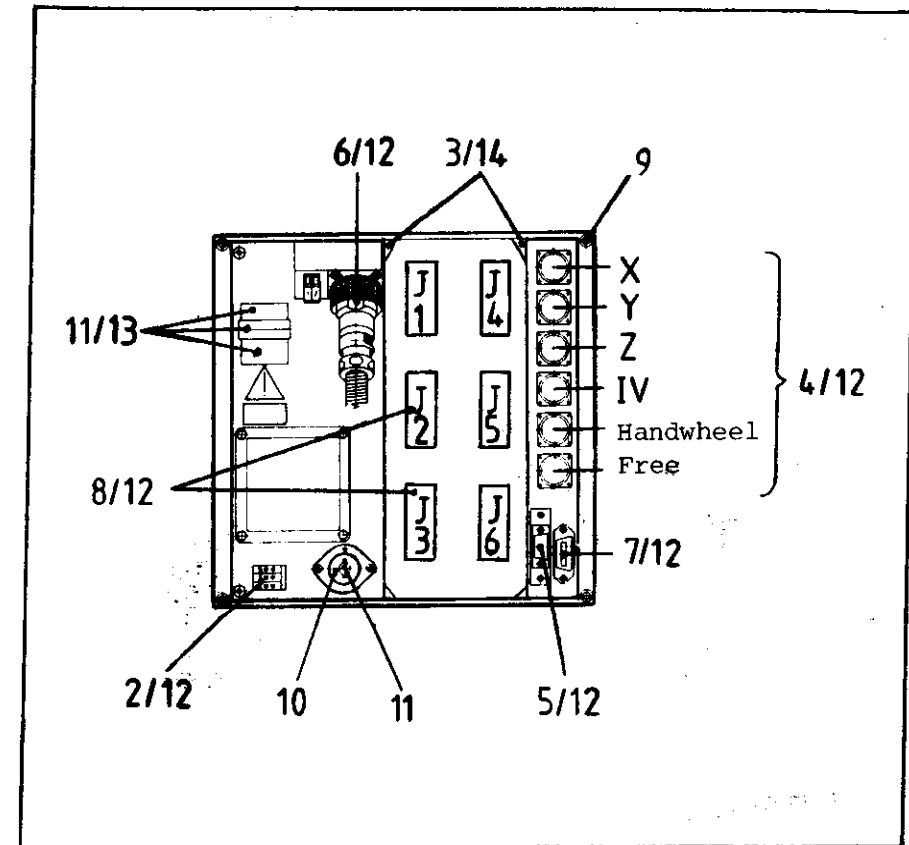

Kundendienst

3.1.2 Procedure for exchanging the TNC 155 P/V Control

1. Gain access to the rear of the Control.
2. Remove the mains supply.
3. Remove the connector box cover-plate from the rear of the Control.
4. Mark the measuring system plugs (X,Y,Z,IV, Electronic Handwheel) and remove them.
5. Disconnect the VDU from the Control.
6. Disconnect the Handwheel Unit from the Control (if present).
7. Disconnect any external data devices.
8. Disconnect connector strips J1-J3, using a screwdriver to prise the connectors apart (Do not unscrew individual wires).
9. Remove the connecting cable P2 to the PL 100 B/110 B from the Control.

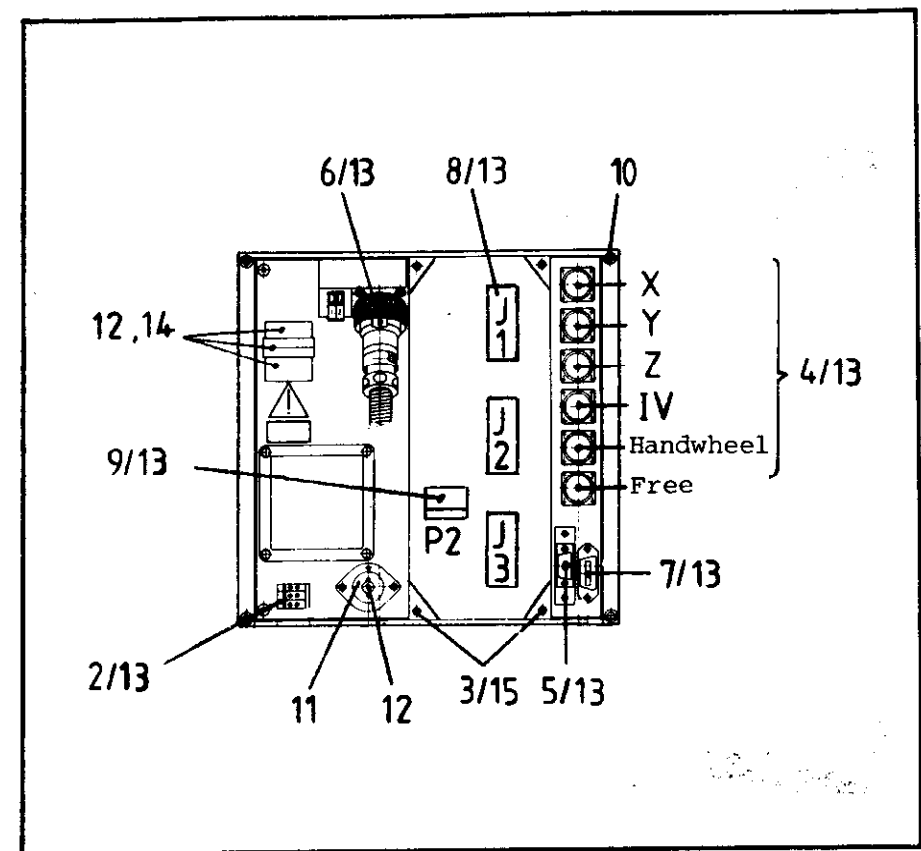
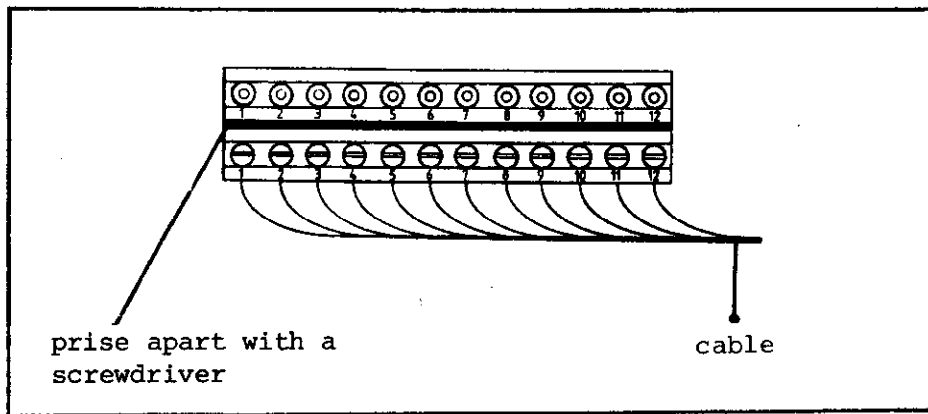

10. Remove the faulty Control, removing the fixing screws if not already removed in 1.
11. Install the new Control - check the voltage-selector position.
12. Check the fuse-rating (see type-plate).
13. Reconnect all cables previously removed.
14. Obtain from the type-plate the Control's Id. No., NC and PLC Software Nos., and write them in the machine handbook.
15. Refit the connector box cover-plate.
16. Turn on the mains voltage.
17. Reprogram the machine parameters.
18. TNC is now ready to use.

Kundendienst

3.1.3 Procedure for exchanging the PLC I/O Board of the PL 100 B/110 B

1. Remove the fixing screws of the heatsink cover-plate.
2. Remove the heatsink cover-plate.
3. Disconnect the TNC 155 connecting cable.
4. Disconnect connector strips J1-J9, using a screw driver to prise the connectors apart.
(Do not unscrew individual wires)
5. Remove the voltage supply (+24V and OV)
6. Remove the fixing screws of the PL 100 B/110 B unit.
7. Install the new unit following the above procedure in reverse order.

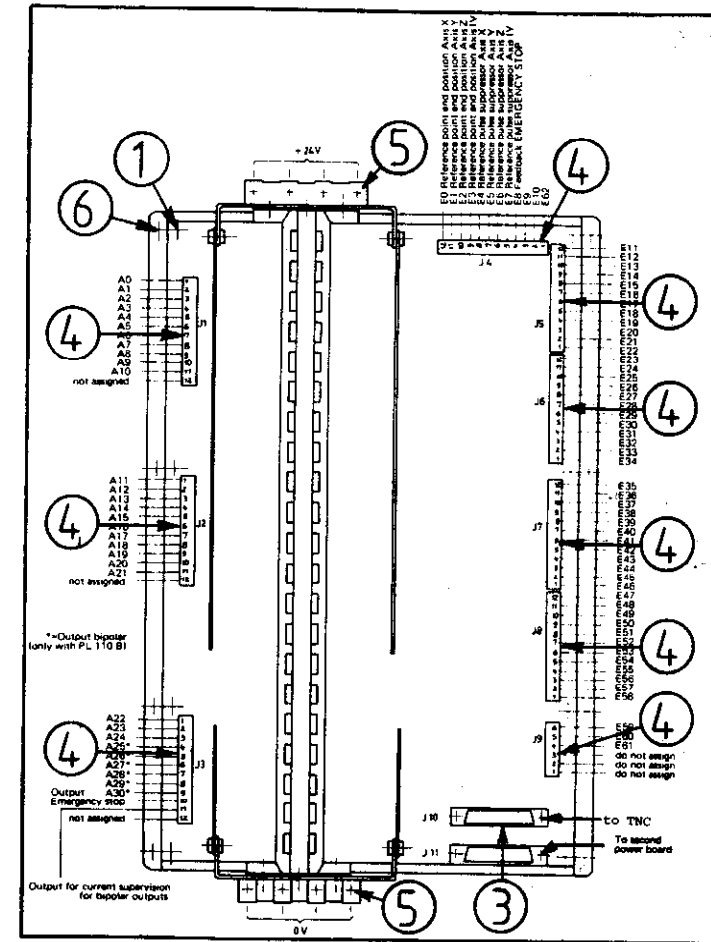

Kundendienst

3.2 Board Exchange

Board Arrangement

The TNC 155 consists of three main sections:

- 1) The frontplate/Keypad Board assembly;
- 2) The housing/Connector Board assembly, with five plug-in boards, namely:
 - .Memory Board
 - .Main Processor Board
 - .CLP-Graphics Board
 - .Analogue Board
 - .either SE Board TNC 155 A/E or PLC Interface Board TNC 155 P/V
- 3) The backplate, Power Supply Unit and Terminal Board assembly.

Board arrangement TNC 155 A/AR/P/PR

TNC 155 E/ER/V/VR

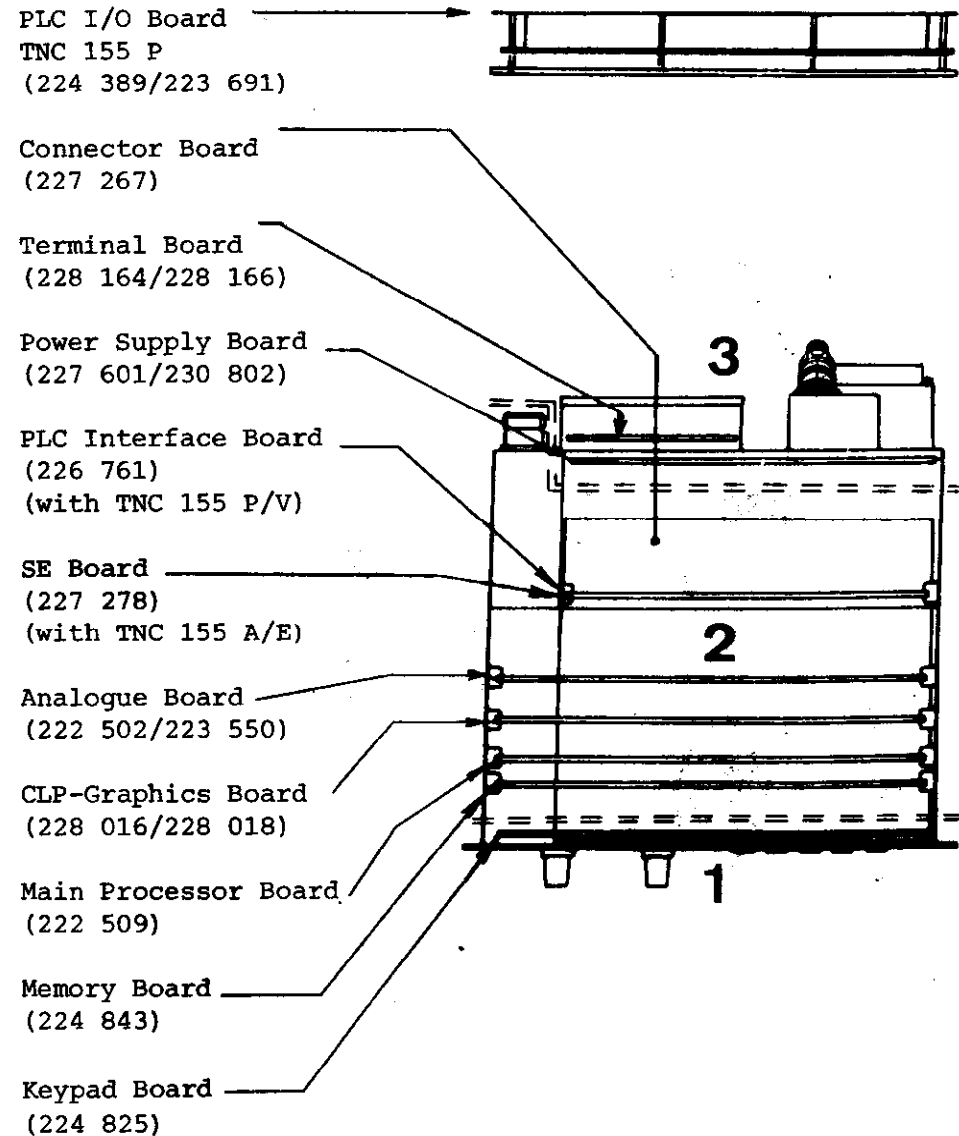

Kundendienst

Caution: .Please observe MOS protection measures when exchanging boards.
 .Exchange boards with the same assembly no. only.
 The assembly no. is impressed on every board, on the left of the serial no.

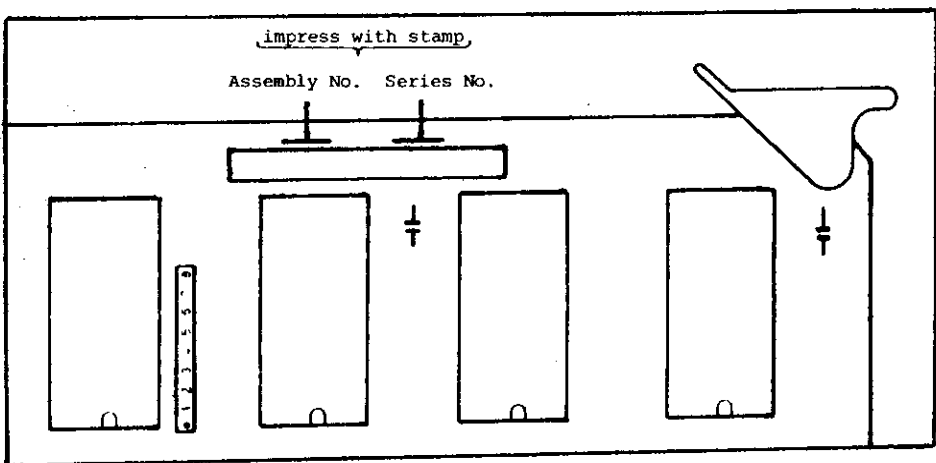

Work area requirements

The TNC 155 contains sub-assemblies with MOS elements. Although MOS ICs are equipped with an input protection diode network, to eliminate the build-up of static charges care must be taken when handling these elements. The following requirements in the work area must be met: Prior to working with MOS components or with assemblies containing MOS elements, all table coverings, instruments, tools, and work personnel must be properly grounded.

A portable "MOS-HANDLING-SET" for field service is necessary when exchanging the operating software and/or servicing the TNC 155:

- 1 a conductive work surface
- 2 a wristband that provides an electrical connection between person and conductive work surface
- 3 a cable that equalizes potential differences between conductive work surface and ground

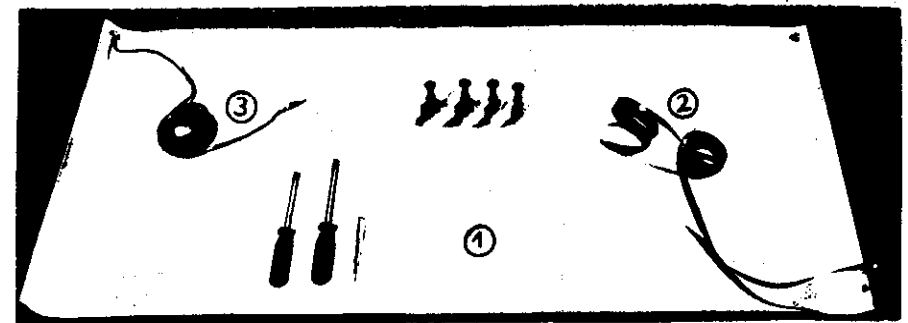

Kundendienst

Exchanging the pluggable boards

Unscrew the 5 mounting screws and remove the housing cover.

Removing the boards:

Press the board ejector keys outwards and pull out the individual board from the top.

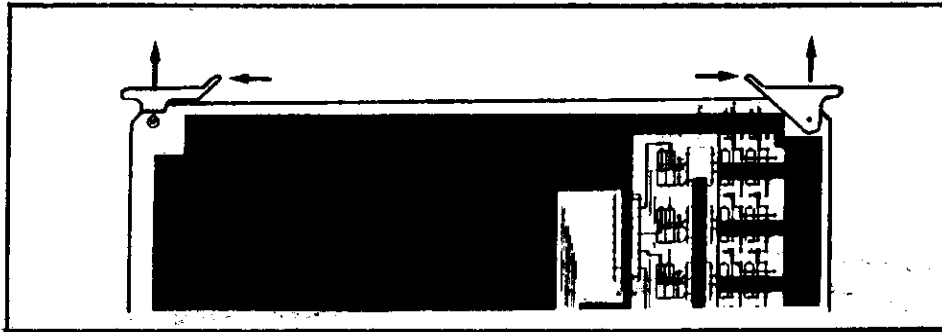

Analogue Board

Before removing the Analogue/Analogue TTL Board pull off and mark the connector plugs for the measuring system inputs/square wave signal inputs and the electronic handwheel input. The connector sockets on the board are coded with coding pins.

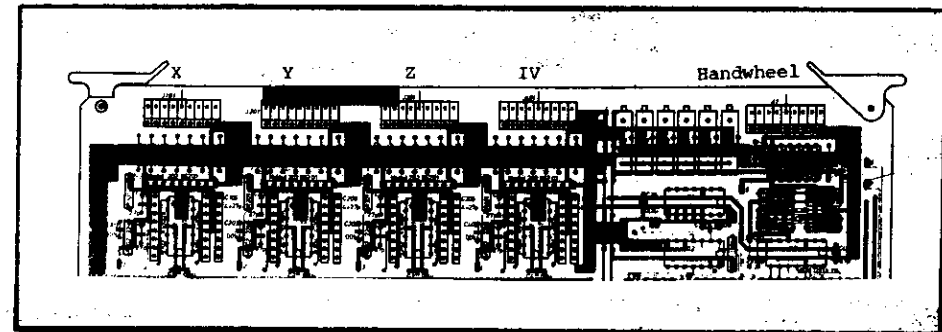

Inserting the boards:

The connectors of the boards are coded: incorrect insertion is therefore avoided. Press the board firmly into the Connector Board using the ejector keys tilted inwards.

Main Processor and CLP-Graphics Board:

When exchanging these boards insert program EPROM's IC-P3 and IC-P19 on the CLP-Graphics Board and IC-P4 to IC-P10 on the Main Processor Board.

Memory Board:

During the exchange or removal of the Memory Board the buffered RAM will no longer be supplied with voltage, which means that the machine parameters and any user-programs will be lost! Before inserting the new Memory Board plug in the relevant EPROMs (EPROM IC-P11 to IC-P18), paying particular attention to their correct location and orientation.

Kundendienst

Exchanging the Keypad Board:

- .Remove the 6 cross-head fixing screws from the frontplate.
- .Tilt the frontplate outwards.
- .Remove connectors J13 (feedrate-override potentiometer) and J14 (spindle-override potentiometer) from the Connector Board.
- .Remove the ribbon cable connector P10 from the Keypad Board.
- .Remove the 7 cross-head fixing screws which secure the Keypad Board to the frontplate.
- .Pull off the Keypad connectors, P1 to P9 from the Keypad Board.
- .Remove the Keypad Board.

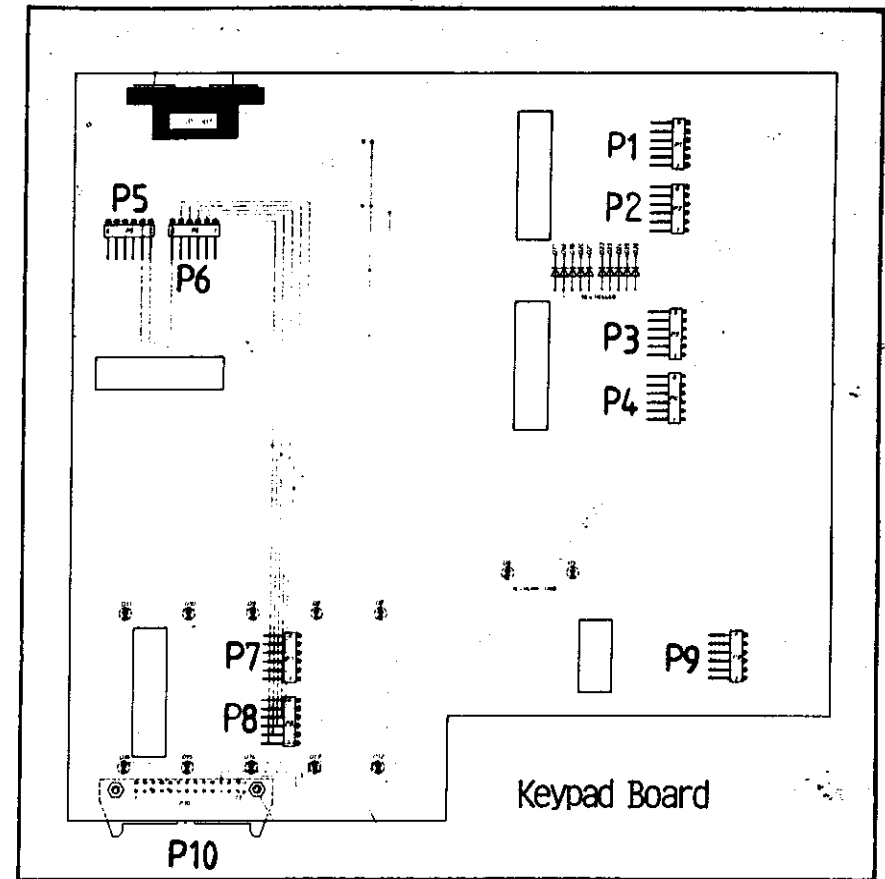

When rebuilding the assembly, ensure that the keypad connectors are firmly engaged in their respective sockets, and that the LEDs project through the corresponding bored holes in the keypad housing.

Kundendienst

Exchanging the Power Supply Unit:

- .Remove the 4 cross-head mounting screws from the rear of the Control (2 screws are found in the connector box).
- .Remove the back wall with the Power Supply Unit and Terminal Board.
- .Disconnect the ribbon cable connector, P1, from the Connector Board (see diagram).
- .Remove the voltage supply plug, P2, from the Connector Board (see diagram).

Exchanging the Connector Board:

- .Remove the 2 cross-head fixing screws of the V.24 connector on the rear of the Control.
- .Push the V.24 socket through its recess in the Control housing.
- .Unsolder the connectors to the VDU socket from the Connector Board (solder terminals 1,4,5,6,7,8,10). Note the colour of the wire connected to each terminal.
- .Pull the Connector Board from the front of the Control housing.

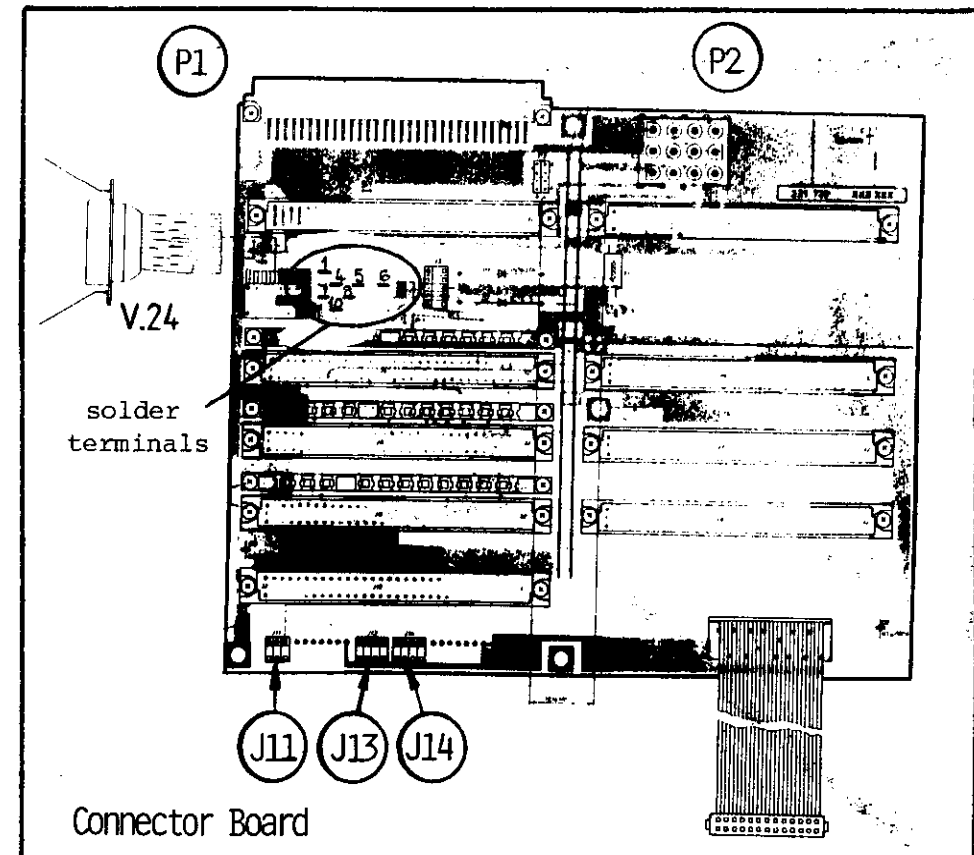

Kundendienst

3.3 Software Exchange

General

The TNC 155 operating software is stored in 17 EPROMs.

- IC-P3, IC-P19 (CLP-Graphics Board)
- IC-P4...IC-P10 (Main Processor Board)
- IC-P11..IC-P18 (Memory Board)

Every operating software is specified with an 8 digit Software No.

example: 227 020 01 complete software Id. No.
 227 020 primary software Id. No.
 01 update software index

Each of the 17 programmed EPROMs (IC-P3...IC-P19) is specified with an 8 digit Id. No.

example: 227 116 CA complete Id. No. of the Prog. EPROM
 227 116 primary Id. No. of the Prog. EPROM
 C position on the board
 (C = IC-P12, HEXadecimal counting
 manner)
 A update index

The operating software includes

- o NC software (IC-P3...IC-P8, IC-P10...IC-P19)
- o PLC software (IC-P9)

TNC 155 **A**: Control with o NC software and
 o PLC standard software

TNC 155 **P**: Control with o NC software and
 o PLC standard software, or
 PLC custom software

The dialogue language of the TNC 155 is determined by IC-P10 (located on Main Processor Board) and is discernible from the different Id. Nos. of the programmed EPROMs.

Following dialogue languages are available at this time

- German (D)
- English (GB)
- French (F)
- Italian (I)
- Spanish (E)
- Swedish (S)
- Finnish (SF)
- Dutch (NL)

The Id. No. of the other programmed EPROMs are the same (for a given IC position) in all languages. (prerequisite: same software issue!)

Exception: IC-P9 (PLC software)

The standard PLC program (EPROM position IC-P9) can be replaced with a custom PLC program for the TNC 155 **P**.

IC-P3

The export NC Software differs from the standard NC Software in EPROM position IC-P3.

The dot matrix for all VDU displayed characters is contained in IC-P19 (character generator).

Kundendienst

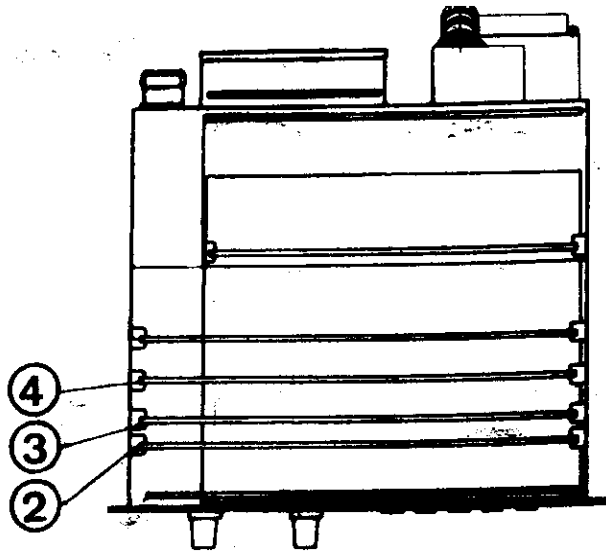
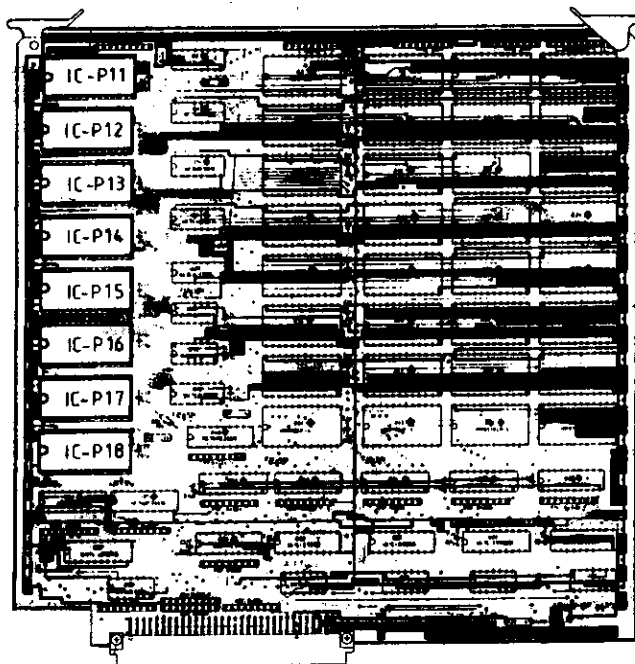
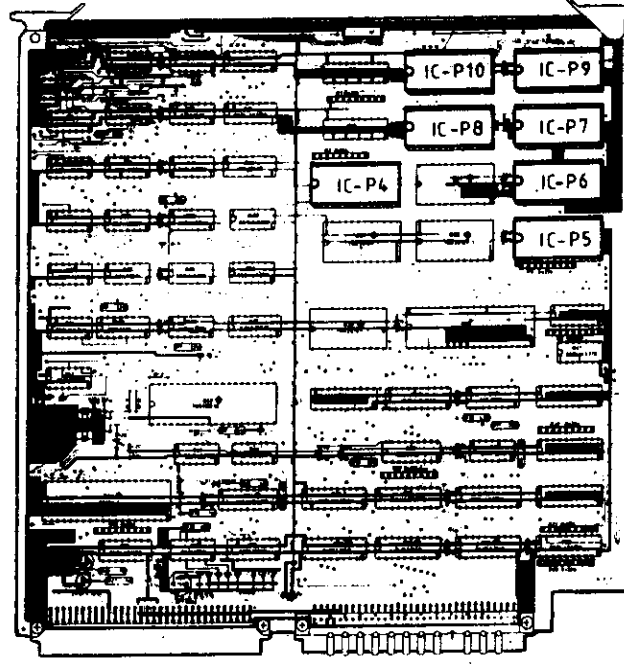

Illustration left: Arrangement of PCBs in the Control

Illustration below: Arrangement of EPROMs on the various boards



② Memory Board
 224 843 ..



③ Main Processor Board
 222 509 ..

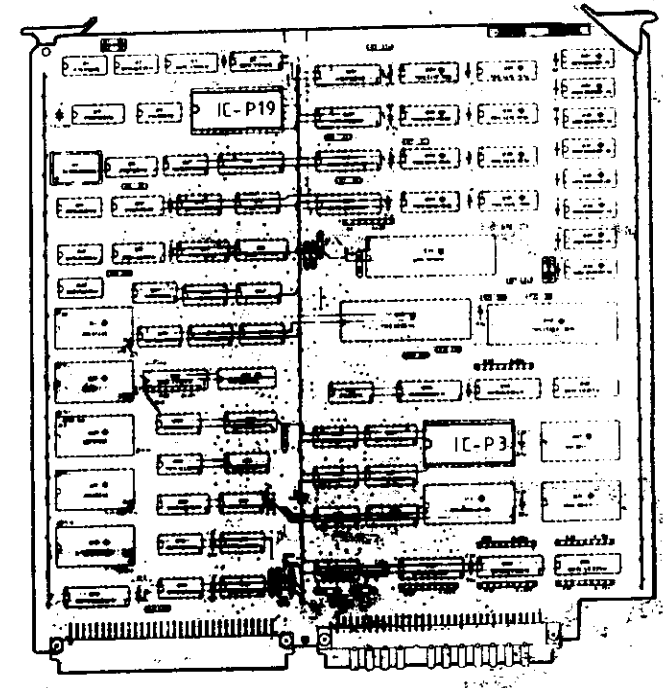

④ CLP-Graphics Board
 228 016 ..

Kundendienst

Software Exchange

Caution: When exchanging the software observe the MOS protection procedures!

- o The cover of the Control can be removed after unscrewing the 5 cross-head mounting screws (top side)
- o To exchange the program, the following boards
 - Memory Board 2
 - Main Processor Board 3
 - CLP-Graphics Board 4
 have to be removed from the assembled Control

There to, lift the board ejector keys and press outwards, pull out board from above and lay onto MOS protection mat.

- o Push screwdriver blade carefully between EPROM and socket, remove EPROM with extraction tool and place onto MOS protection mat.
- o Insert EPROM into appropriate socket using insertion tool.

Important: - When exchanging EPROMs, observe the position number (second to last digit of the programmed EPROM Id. No., hexa-decimal counting manner)

- The EPROM package index must point in the same direction as the ICs on the board.
- Visually check if the EPROMs are contacting their respective sockets after an exchange.

- After the software exchange has been concluded, the Id.-Nos. of the NC and PLC software have to be changed. The description plate for the software numbers is found on the rear of the Control under the type-plate.

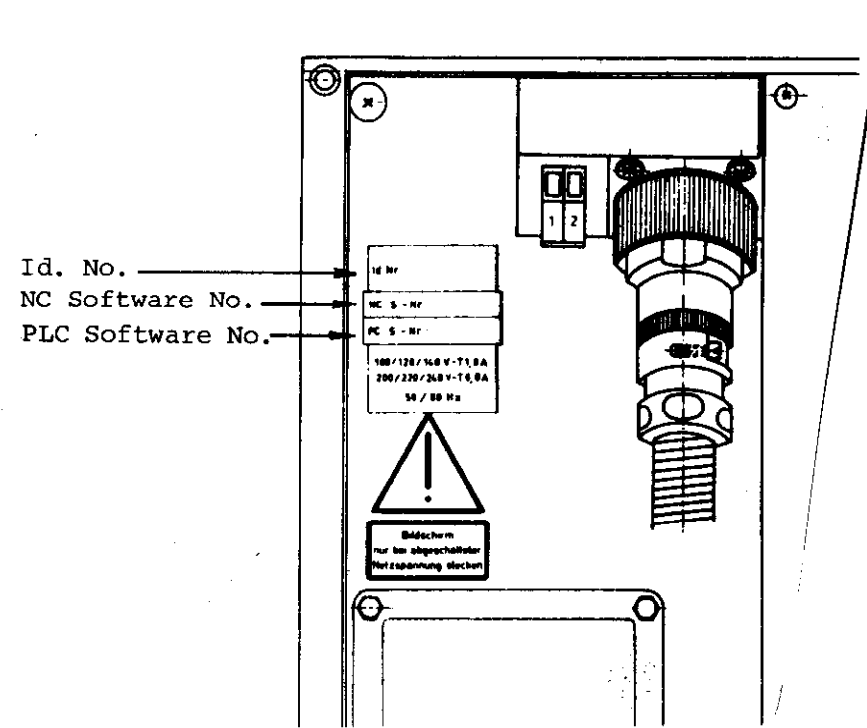

The RAM memory of the Memory Board is unbuffered during the EPROM (software) exchange. The machine parameters and any stored user-program are therefore erased!

For continued operation, the machine parameters have to be re-entered into memory.

Kundendienst

3.4 Replacement Parts, Loan/Exchange/Service Units

Replacement Parts TNC 155

In general, replacement parts are available for all sub-assemblies discernible from the wiring diagrams (see section 4.3). However, it is strongly recommended that all repairs and maintenance work are entrusted to an official HEIDENHAIN agency. No responsibility can be accepted by DR. JOHANNES HEIDENHAIN GmbH for repairs undertaken by anyone else.

The list on page 49 shows the Id. Nos. and names of all parts available for the TNC 155. These parts can be ordered from the department **Kundendienst** (Customer Service) at HEIDENHAIN Traunreut. It is of utmost importance, when ordering, to give (i) the Id. No., (ii) the name, in German, and (iii) the quantity of each part required. Telexed order should be sent to the Kundendienst Telex: 17 866 982 or Teletex 866 982.

Loan, Exchange, Service Units

In order to keep machine down-time as short as possible, HEIDENHAIN offers a loan and exchange service.

Loan units

Loan units are available, free of charge, for the duration of a repair carried out at HEIDENHAIN Traunreut or by an official HEIDENHAIN agent. The only charges to the customer are the shipping charges.

Exchange units

An exchange unit can be requested for a unit that is returned for repair. This exchange unit is equipped with the latest hardware and software issue and is externally in excellent condition. The only charges to the customer in this case are for the repair of his own unit.

Transaction

Requested loan or exchange units are shipped on the date of request, or the following day, provided that the unit is available from our stock.

A customer's faulty unit should be returned to DR. JOHANNES HEIDENHAIN within 14 days of receiving the exchange unit.

Service units

Service units are new units which are used for service purposes and can be obtained from DR. JOHANNES HEIDENHAIN at non-repeatable discount prices.

Kundendienst

Id. No.	Name	Id. No.	Name
225 028 ..	TNC 155 A/E	227 278 ..	Platine, SE (SE Board)
225 029 ..	TNC 155 AR/ER	226 761 ..	Platine, PC-Interface (PLC Interface Brd.)
225 030 ..	TNC 155 P/V	228 164 ..	Platine, Klemmleiste (Terminal Brd. for A/E units)
225 031 ..	TNC 155 PR/VR	228 166 ..	Platine, Klemmleiste (Terminal Brd. for P/V units)
223 836 ..	PL 100 B Leistungs-Pl. (PLC I/O Board)	224 825 ..	Platine, Tastatur (Keypad Board)
223 216 ..	PL 110 B Leistungs-Pl. (PLC I/O Board)	227 267 ..	Platine, Stecker (Connector Board)
226 917 ..	BE 411 Bildschirmereinheit (12" Graphics VDU)	213 204 ..	Tastenfeld kompl.-20 Tasten (20-key keypad assy.)
212 282 ..	Gehäuse, Frontteil TNC (Front panel)	217 737 ..	Tastenfeld kompl.-10 Tasten (10-key keypad assy.)
216 394 ..	Gehäuse, kompl. (Housing assy.)	212 426 ..	Tastenfeld kompl.- 4 Tasten (4-key keypad assy.)
225 037 ..	Gehäuse, Tastatur-Vorsatz (ISO format keypad)	217 532 ..	Halter, Batterie kompl. (Battery holder assy.)
224 843 ..	Pl., Speicher-3160 Sätze (Memory Brd.-3160 Blk.)	228 168 ..	Potentiometer kompl. (Potentiometer assy.)
222 502 ..	Pl., Analogteil - Sinus (Analogue Brd.-Sinewave)	202 370 ..	Spannungswähler m. Si.-halter (Voltage selector+fuse)
223 550 ..	Pl., Analogteil - TTL (Analogue Brd. - TTL)	213 206 ..	Klemme Netz- 3 pol. kompl. (3-way mains conn.)
222 509 ..	Platine, Hauptrechner (Main Processor Brd.)	215 091 ..	Trafo BV 15714 (Transformer)
228 016 ..	Pl., Regelkreis/Grafik (CLP-Graphics Brd.)		
227 601 ..	Platine, Netzteil (alt) (PSU Board old)		
230 802 ..	Platine, Netzteil (neu) (PSU Board new)		
212 387 ..	Platine, Entstör (Mains Filter Board)		

Kundendienst

4. Additional Information

4.1 Block Diagram Description

General

The TNC 155 block diagram shows, in simplified form, the internal functional units of the control, their relationship to the various boards, and their interconnections. The graphic layout of the diagram and the way it is included in single sheets.

- the representation of any of the TNC 155 models (A/AR/P/PR),
- simplified representation of functional processes

Numbers enclosed in dashes inform about the board and its functional unit.

e.g.: -50.1-

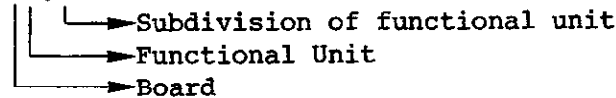

Simplified Description of the TNC 155 (Block Diagram)

- Keypad Board (1)
- Memory Board (2)
- Main Processor Board (3)
- CLP Processor/Graphic Board (4)
- Analogue Board/Analogue Board TTL (5)
- with SE Board (6) it corresponds to a A(E)-Type;
- without SE Board, with PLC Interface (6), however
- with PLC I/O-Board(s), it corresponds to a P(V)-Type or, respectively, PR(VR)-Type
- Power Supply Board (7)
- Terminal Board (8)

The functional processes of the control are divided between two microprocessor systems, each comprising:

- Microprocessor (TMS 9995)
- Program Memory (EPROMs)
- Write-Read Memory (RAMs)

- Input/Output facilities (e.g. keypad, screen, measuring system inputs, analog outputs, LEDs, V.24 interfaces etc.)

The functions of the control are divided between the two microprocessor systems as follows:

1. "Main Processor System"
 - Keyboard, LEDs
 - User Program Interpreter
 - Provision of programming "environment"
 - Generation of PLC program addresses
 - * - Transfer of input and output states between PLC Interface Board, SE Board and PLC RAM
 - * - Control of the V.24 interface
 2. "CLP-Processor System"
 - Ascertainment of instantaneous positions
 - Interpolation Calculations
 - VDU Control
 - * - Demand Speed Values to DAC
 - * - Interface with handwheel unit
- * Serial data transfer via CRU bus.

Main Processor Unit

- Primarily on the main processor board and the memory board.
- The operating system software is held in EPROMs:

-30.1-	IC-P4 (not mapped)	
-30.3-	IC-P5...IC-P8	
-30.3-	IC-P10 (dialogue language)	Main Proc. Board
-20-	IC-P11...IC-P18	Memory Board

Kundendienst

- The RAMs -30.2- on the main processor board can be accessed either by the main processor -30- or by the CLP processor -40-. The intended coordinates, programmed feed, display texts etc. can therefore be transferred. These RAMs also serve as register file memory for the main processor -30-. User programs, machine parameters, and (under certain circumstances) the PLC program are programmed in RAMs -20.1-.
- The 16-bit address bus is extended to 20-bit by a memory mapper -31-.
- The keyboard controller -32- has the task of driving the LEDs and scanning the keypads -32.1- on the front plate.
- The main processor is connected with V.24 interface -34- via a (serial) CRU-bus. This interface is used to exchange data by means of a magnetic tape unit (ME) or, respectively, an external processor.
- The PLC program contained in IC-P9 -33.1- is processed by the "1-bit-PLC-processor" -33- mounted discretely on the main processor board. The input and output states are stored in a 4k x 1 PLC-RAM -33.2-.
- I/O-Functions:
 - a) TNC 155 A-Versions:

24 galvanically separated inputs (E0 to E23) -60- and 24 floating relay contact outputs (A0 to A22 + emergency stop) -61- on the SE Board. The inputs and outputs are protected on the terminal board (A version) by special protective resistances 5.1k ohms -80- and 47 ohms -80.1-. Protective resistances should never be replaced with normal resistances!
The Analogue outputs are led via LC-filter -81- as protection against the oscillation of analogue outputs.
 - b) TNC 155 P-Versions:

The inputs and outputs are loaded on external PLC I/O-board (e.g. PL 100B or, respectively, PL 100B) which are driven by the main processor -30- via the PLC interface board. The data is serially transferred via the CRU-bus. All lines of this bus as well as the required addresses are galvanically separated by the optocouplers -60- and are converted from the TTL level (5V) to the MOS level (12V) by means of a level converter -61-. Thus a higher noise immunity is obtained.

Under the control of CRU addresses 63 programmable inputs (E0 to E62) -E2- located on the PLC I/O board are multiplexed on CRUIN 1 line. If 2 PLC I/O boards are connected the inputs from the 2nd board are multiplexed on CRUIN 2. On the PLC interface board either CRUIN 1 or CRUIN 2 are selected -64- and are led to the main processor via CRUIN.

The serial CRU OUT signal is converted in 31 outputs via a serial-parallel-converter -E1.1-. The outputs (each having its own current supervision -E1-) are transferred via line drivers to the machine interface.

 - An overloaded output only switches off during the period of the overload.
 - If the current supervision detects overcurrent no emergency-stop results in the standard PLC program. The input E63 is used to indicate an overloaded output to the main processor -30-.

PL 100B: 31 unipolar, programmable outputs + emergency-stop protected against overload.
PL 110B: 26 unipolar, programmable outputs + 5 bipolar outputs + emergency stop protected against overload.

On the PLC I/O board a 12V voltage is generated by an external 24V supply. On the PLC interface board this 12V voltage is transformed in a 5V voltage for its TTL modules.



Kundendienst

CLP Processor/Graphic System:

- Primarily on the CLP processor/graphic board.
- Operating system is contained in EPROM IC-P3 -40.1- (32k x 8).
- The main task is the calculation of the instantaneously intended values of the analog output voltages dependent on:
 - .the instantaneous actual positions
 - .the programmed intended position
 - .the distance of the intended position (influence on deceleration ramp)
 - .the programmed feed rate
 - .the fast traverse rates determined per machine parameter
 - .the settings of the override and feed potentiometerThe calculating speed requires a wait-free RAM -40.2--
- The measuring system signals are processed on the analog board. These signals are amplified at first -50.1- and then subdivided -50- by delaying (phase shifted) and combining them differently. The subdivided 0 degree, 90 degrees and RI signals are then led to the gate arrays -42- of the CLP processor board. The gate arrays are especially developed LSI circuits consisting of different gates and counters in which the direction of the movement and the number of pulses are calculated. This information can then be scanned by CLP processor -40- to ascertain the actual values of the axes.
- The symmetry, the on-to-off ratio and the amplitude of the system signals are constantly controlled by a supervision circuit -50-.
- The signals from the handwheel (if present) are shaped via the functional block -53- and are also processed by the CLP processor.
- If the distance between the control and measuring system is more than 20m, an EXE has to be interposed. The measuring signals are thus already amplified, subdivided, evaluated, supervised and converted in TTL signals. An "R" version of the control is used accordingly (e.g. TNC 155 AR) equipped with a combined EXE connection for X-, Y-, and Z-axis and an analog board TTL. The input amplifiers and the wiring for the signal subdivision are replaced with line receivers -50- on this analog board whose outputs are directly connected to the gate arrays -42- on the CLP processor board. The supervision signal of the EXE is also buffered -50- and transferred to the CLP processor board. The signals of the handwheel are likewise processed -53- as on the "normal" (sine) analog board.
- If instead of linear position transducers incremental encoders are used to ascertain actual values a reference pulse appears once per revolution. Since only one reference pulse is to be evaluated all other reference pulses of the axes X, Y, Z, IV are inhibited on the analog board -50-. The signal lines are connected with the analog board via the PLC I/O board and the PLC interface board. The level conversion MOS/TTL as well as the galvanic decoupling is carried out on the PLC interface boards via -61- and -60-.

Kundendienst

- The data of the CLP processor is transferred to the analog outputs via the serial CRU bus. The digital output values calculated for all axes are multiplexed on the CRU OUT line and are converted in a 12 bit parallel format on the analog board. These successive digital values are then converted in analog values (voltages) by means of a DAC -52.1- (digital-analog-converter). These voltages are compared with the adjusted values of the override and feed potentiometers -52- and the results are transmitted to the CLP processor via CRUIN. The output voltages can thus be adapted to the values adjusted by the override or, respectively, the feed potentiometer. The X-, Y-, Z-, IV- and S-analog values generated shortly one after the other at the output of the DAC are allocated to the single axes by means of five sample and hold circuits -52.2-. The five individual analog voltages are amplified and buffered subsequently -52.3- and are led to the terminal board.
- On the analog board the buffer battery (-3,46V) and the internal temperature (65°) of the control are also supervised -51-. The supervision signals are led to the CLP processor via the CRUIN line.
- Two "watch dog" monoflops -51.1- are on the analog board. These must be triggered separately once every 5ms by the CLP processor -40- and once every 20ms by the main processor -30-. If the monoflops are not driven within 5ms or 20ms (error state), an emergency-stop signal is triggered.
- The display screen can either be operated in the text/graphic mode. The control of the routine procedures required for the text/graphic representation are taken over by the graphic controller μ PD 7220 -41-. This controller must receive the corresponding commands and the pertaining parameter from the CLP processor via the data bus. To permit the fast generation of a given representation all necessary commands and parameters are calculated in advance and are stored in 64k x 8 dynamic graphic memory -41.1-. Priority decisions between reading

or, respectively, writing and refreshing of the memory are executed by the DRAM controller -41.5-. The graphic controller dependent on the commands received by the CLP processor builds up the required bit pattern in the 32K x 16 video memory -41.6-. The continuous output of these data and the synchronisation signals to the display screen is likewise controlled by the graphic controller. In the graphic mode the 16-bit-pixel-words are read out by the CLP processor and are converted in a serial format via the graphic shift register -41.7-. The signal can be inverted with an exclusive-or-gate -41.7- to generate, under circumstances, an inverse video display.

In the text mode the video memory contains the 6-bit ASCII values and the pertaining mode data. The ASCII values and some of the mode bits form the addresses for the character generator IC-P19 -41.2-. The bit pattern for the momentarily addressed series of the desired sign is converted in a serial format by means of the video shift register -41.3-. Under circumstances an inverse video display can again be generated with the exclusive-or-gate-circuit -41.4-. A discretely built up timer circuit -41.8- synchronizes the procedures of the entire CLP/graphic board. The video, light, HSYNC and VSYNC signals are synchronized by the video output circuit -41.9-.

Kundendienst

- The V.24 signals of the handwheel unit HE 310 are connected to the line driver or, respectively, to the line receiver -62- on the SE board (or, respectively the PLC interface board). A serial interface module -43- on the CLP graphic board is between line receiver/driver and the CLP processor to execute the data transfer with the handwheel unit and to format data (start/stop pulses etc.).
- The signals of the 3D-probe are buffered via the 3D-probe-interface on the SE board (or, respectively, the PLC interface board) -63- and is evaluated via the counter module -42- on the CLP processor/graphic board.

If U2 (+5V) exceeds if there is a failure the overvoltage recognition -73- is immediately effective and causes the overvoltage protection (thyristor) -73.1- to connect through. Thus U1 is short-circuited coming directly from the power supply transformer -74- via the rectifier -75-. A greater damage at the subsequent electronics is thus inhibited by means of this protective measure.

Power Supply Unit

- +5V are generated for the TTL modules via the forward converter -70-. The flyback regulator -70.1- inductively coupled with the flow converter generates +/-15V for the operation amplifier.
- The +12V supply voltage for the V.24 interface is generated with the help of the +15V by means of a linear regulator -70.2-.
- +11V are generated via the forward converter -70.3- for the TNC 151 (BE 111, BE 211) screen which in contrast to the TNC 155 (BE 411) screen does not have an own power supply unit. The switch regulator -70.01- and -70.31- readjust the output voltage load controlled.
- The soft start -71- limits the relatively high switch-on current.
- On the power supply board there is, moreover, a voltage supervision -72- triggering a reset signal if the power supply is interrupted or if the supply voltage drops below a predetermined minimum level (187V if set for 220V operation) for a short time.

Kundendienst

4.2 Block Diagram TNC 155

Block Diagram	Drawing Number	Page
Arrangement	4820 EKD 1603300	56
PLC-I/O-Board	4820 EKD 1605100	57
Power Supply	4820 EKD 1605200	58
Terminal Board (P-Version)	4820 EKD 1605000	59
Terminal Board (A-Version)	4820 EKD 1604800	60
PLC Interface Board	4820 EKD 1604900	61
SE-I/O-Baord	4820 EKD 1604700	62
Main Processor Board	4820 EKD 1603400	63
CLP Processor Board	4820 EKD 1603700	64
CLP Graphic Board	4820 EKD 1603800	65
Analog Board (TTL-Impuls)	4820 EKD 1603600	66
Analog Board	4820 EKD 1603500	67
Memory Board	4820 EKD 1603900	68
Memory Board	4820 EKD 1604000	69

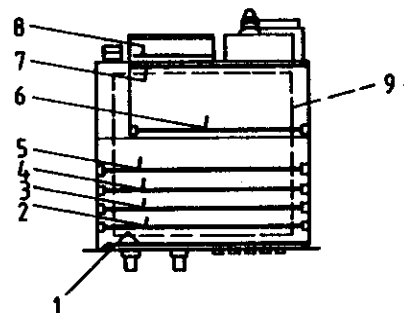
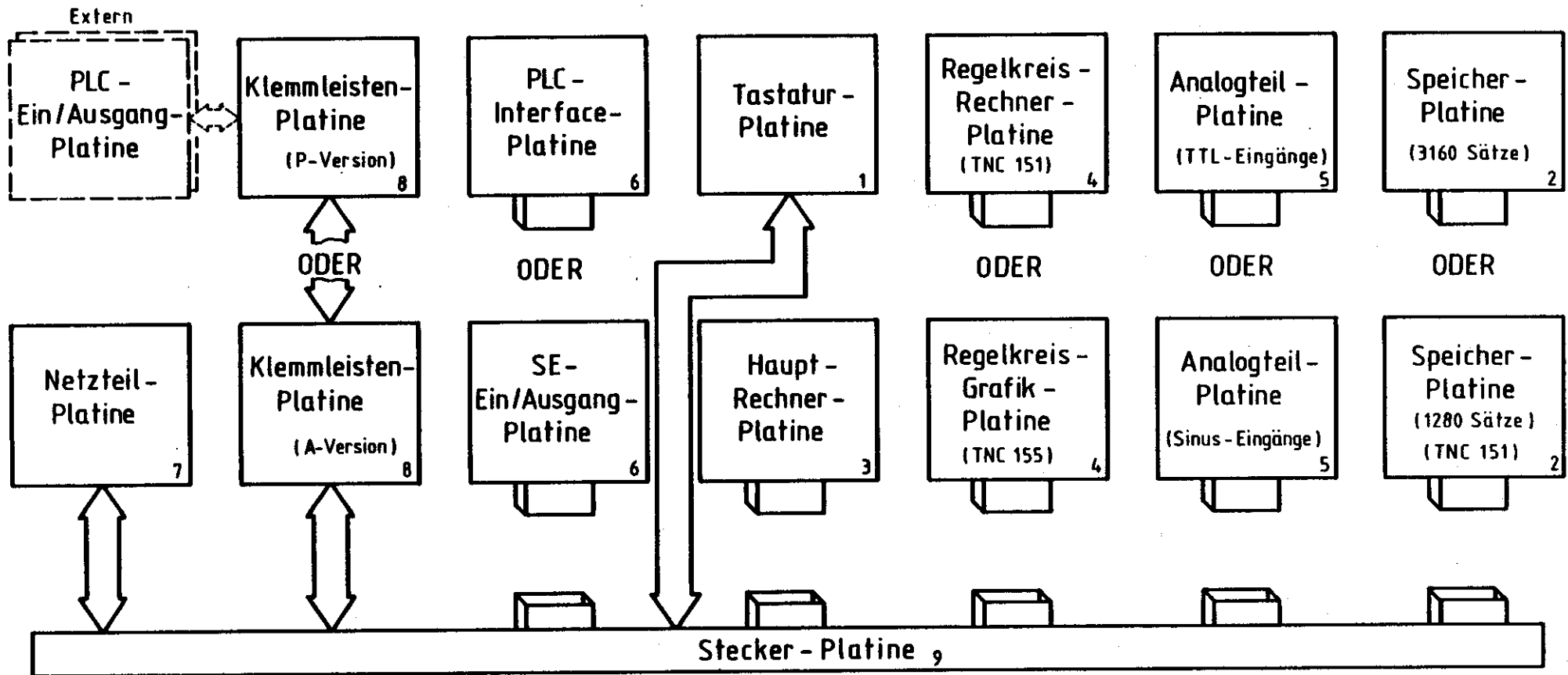

Zeichnungs - Nr.:
4820 E KD 16025 00



Anordnung der Blockschaltbilder
und Platinen für TNC 151 / 155



Maschinen - Schnittstelle

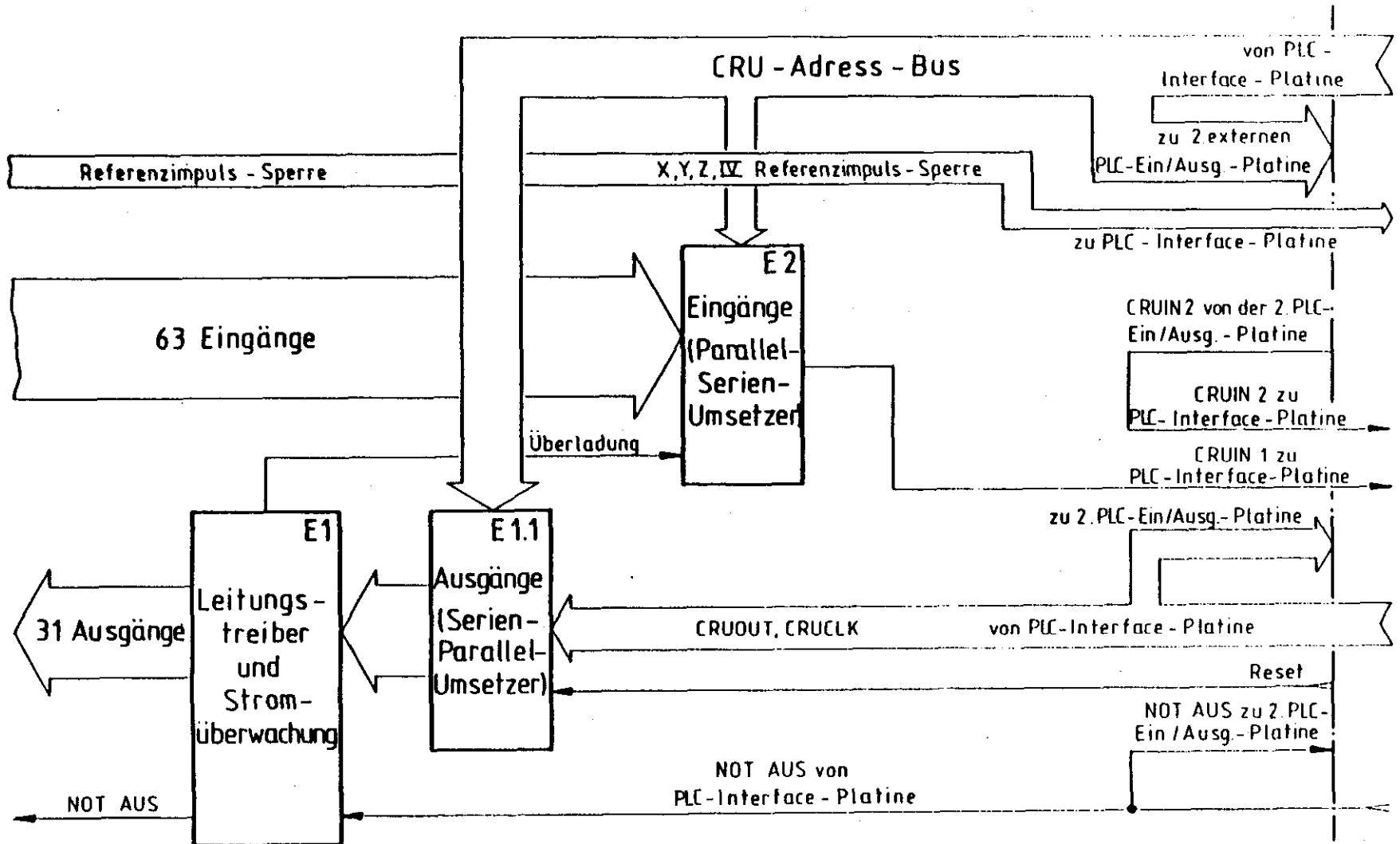

Zeichnungs - Nr.:
4820 E KD 1604500



Blockschaltbild TNC 151/155
(Extern)PLC-Ein/Ausgang-Platine



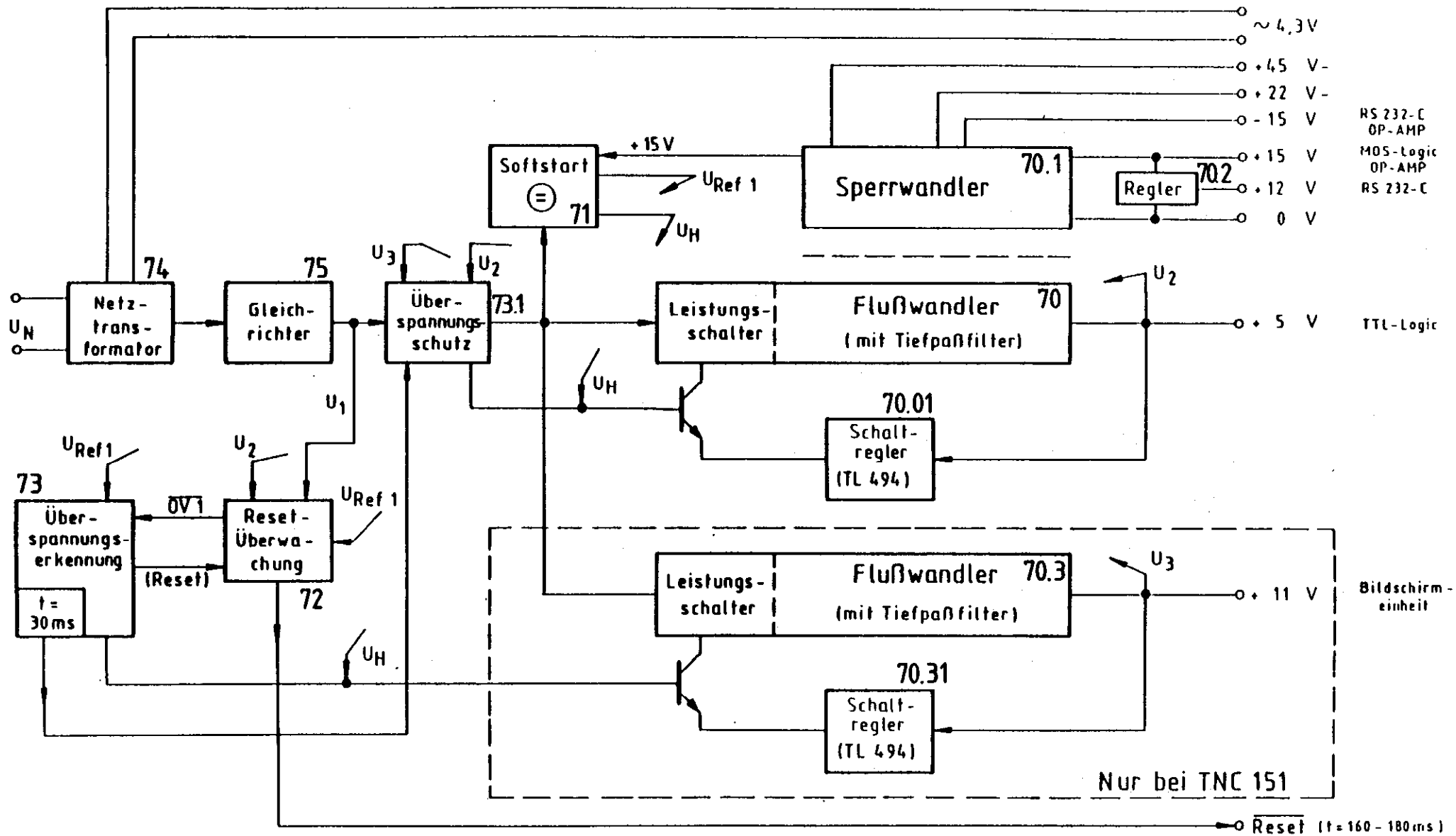

Zeichnungs - Nr.:
4820 E KD16046 00

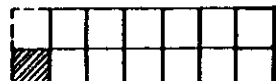

Blockschaltbild TNC 151/155
Netzteil



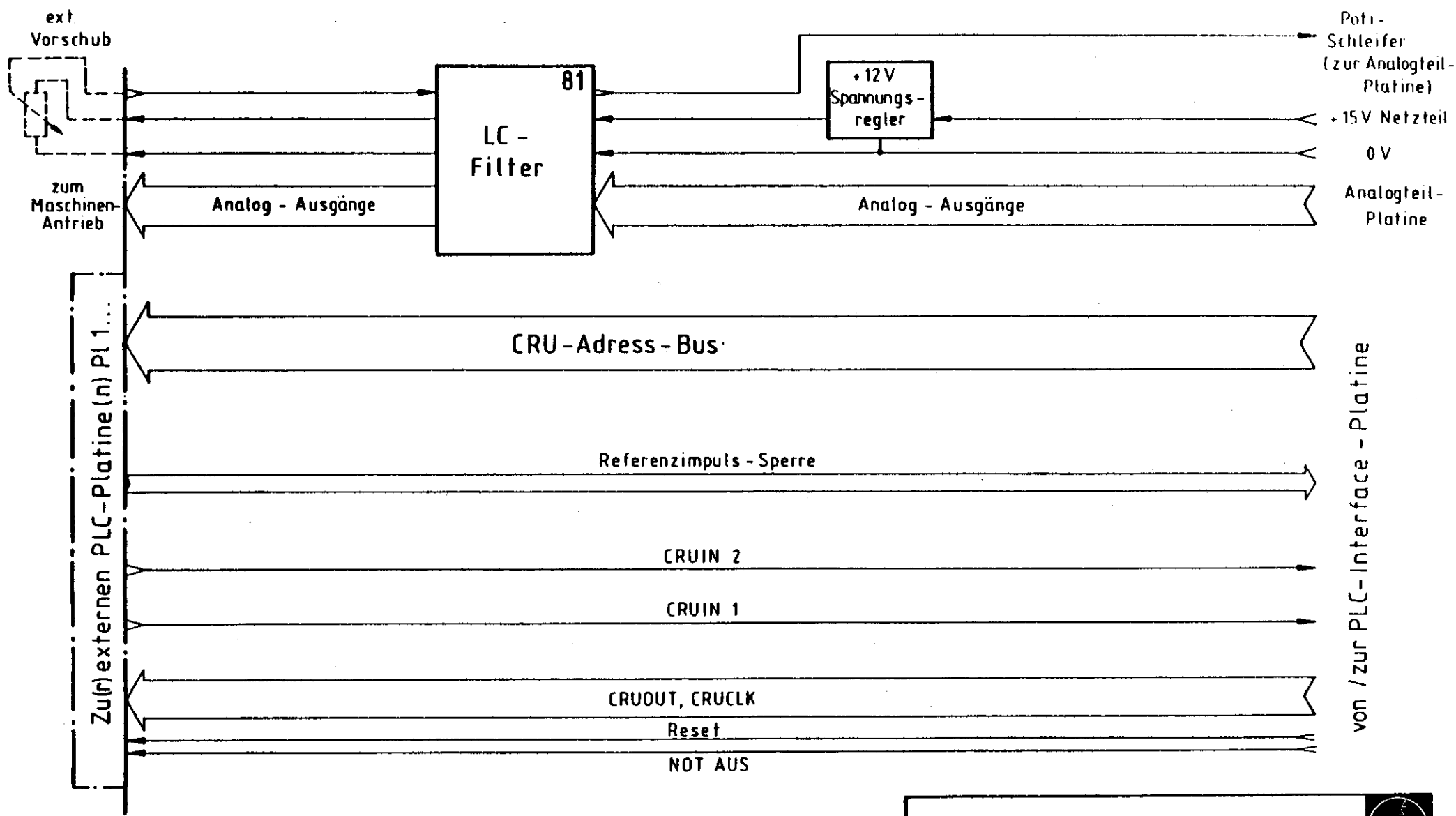

Zeichnungs - Nr.:
4820 E KD 16044 00

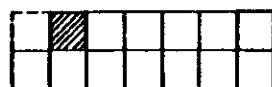

Blockschaltbild TNC 151/155
Klemmleisten-Platine (P-Version)



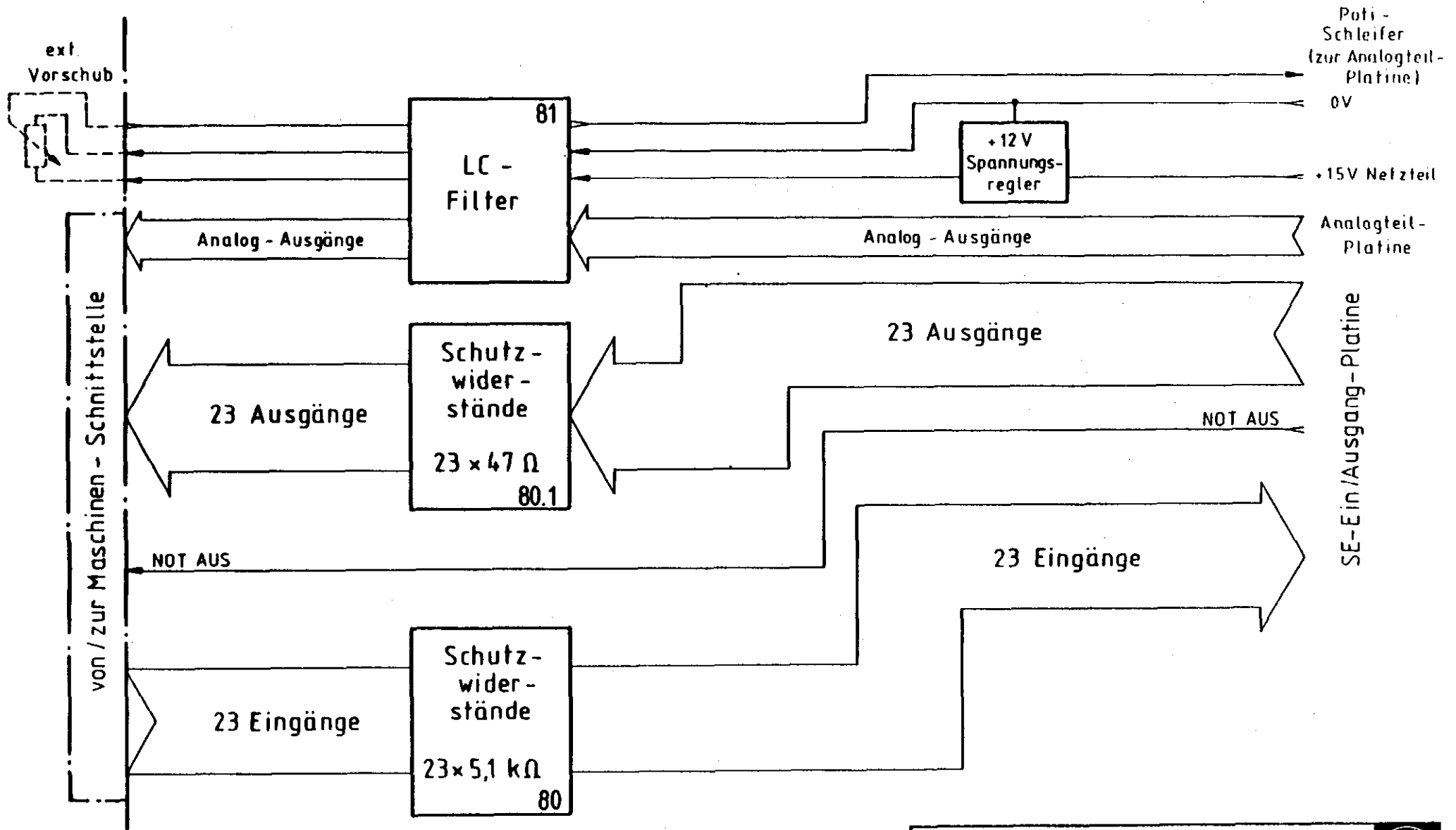

Zeichnungs - Nr.:
4820 E KD1604200



Blockschaltbild TNC 151/155
Klemmleisten - Platine (A-Version)



Zur Klemmleisten - Platine

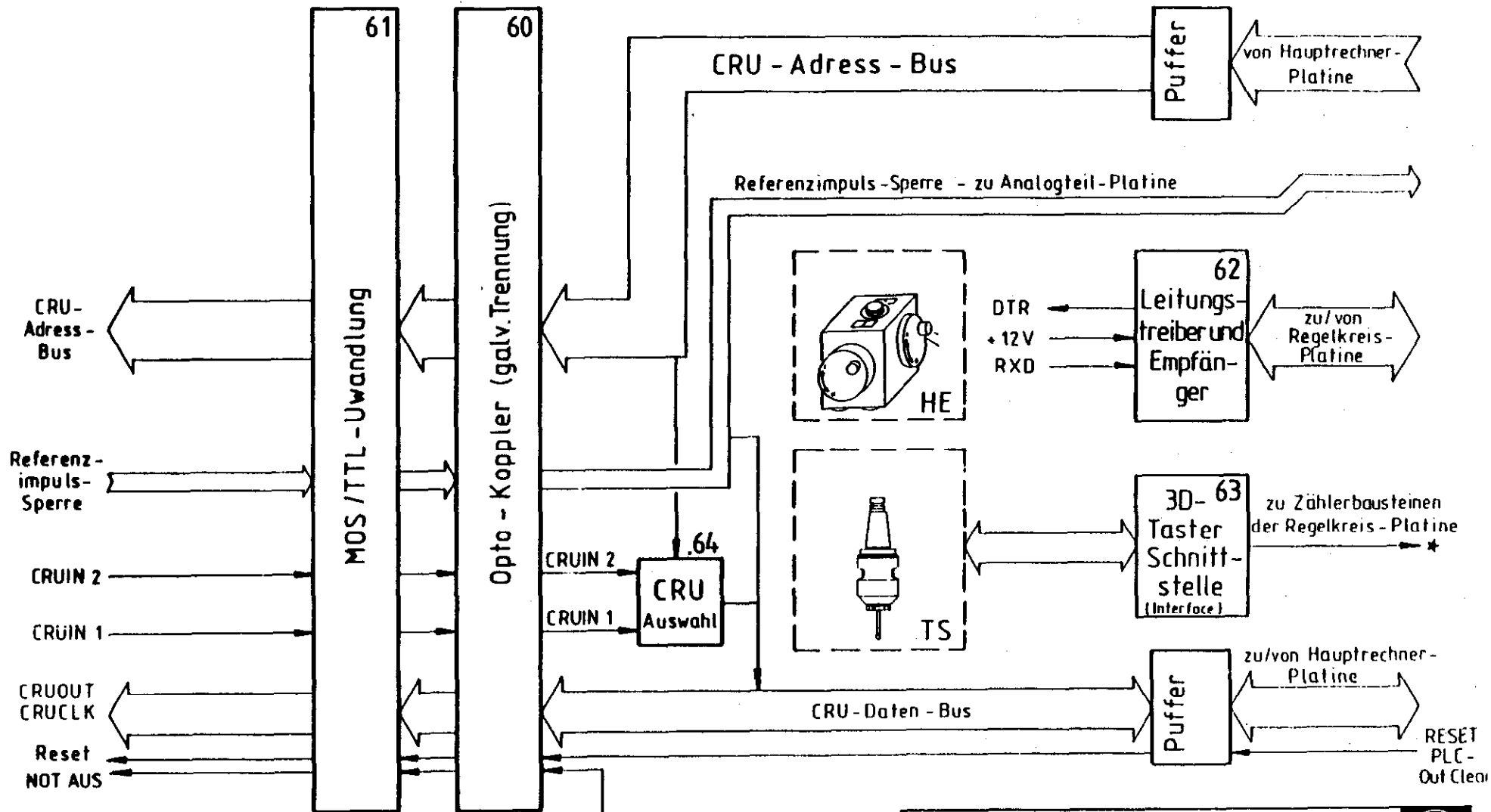

Zeichnungs - Nr.:
4820 E KD 16043 00



NOT AUS
von
Analogteil -
Platine

Blockschaltbild TNC 151/155
PLC-Interface - Platine



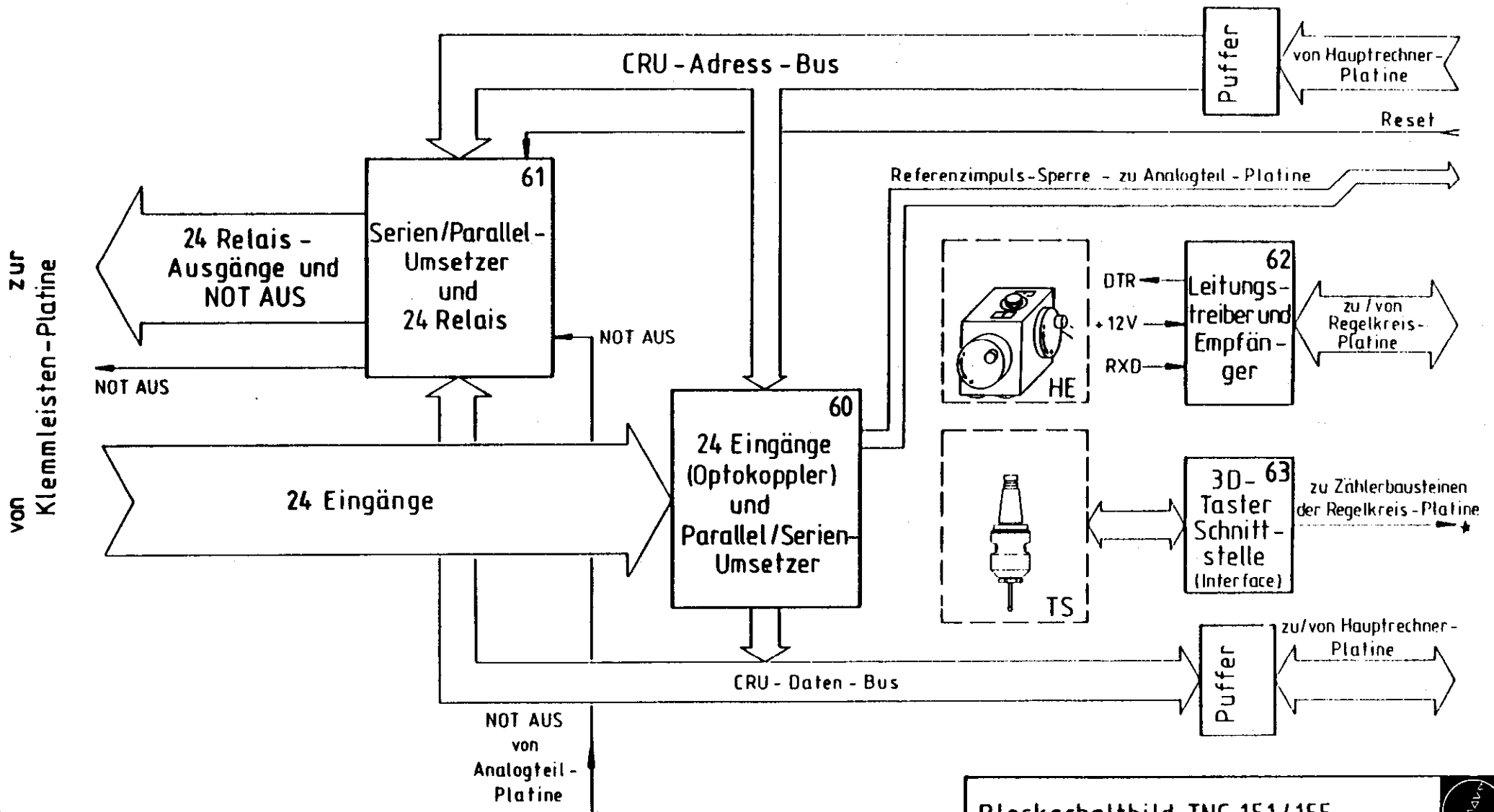

Zeichnungs - Nr.:
4820 EKD 16041 00



Blockschaltbild TNC 151/155
SE - Ein / Ausgang - Platine



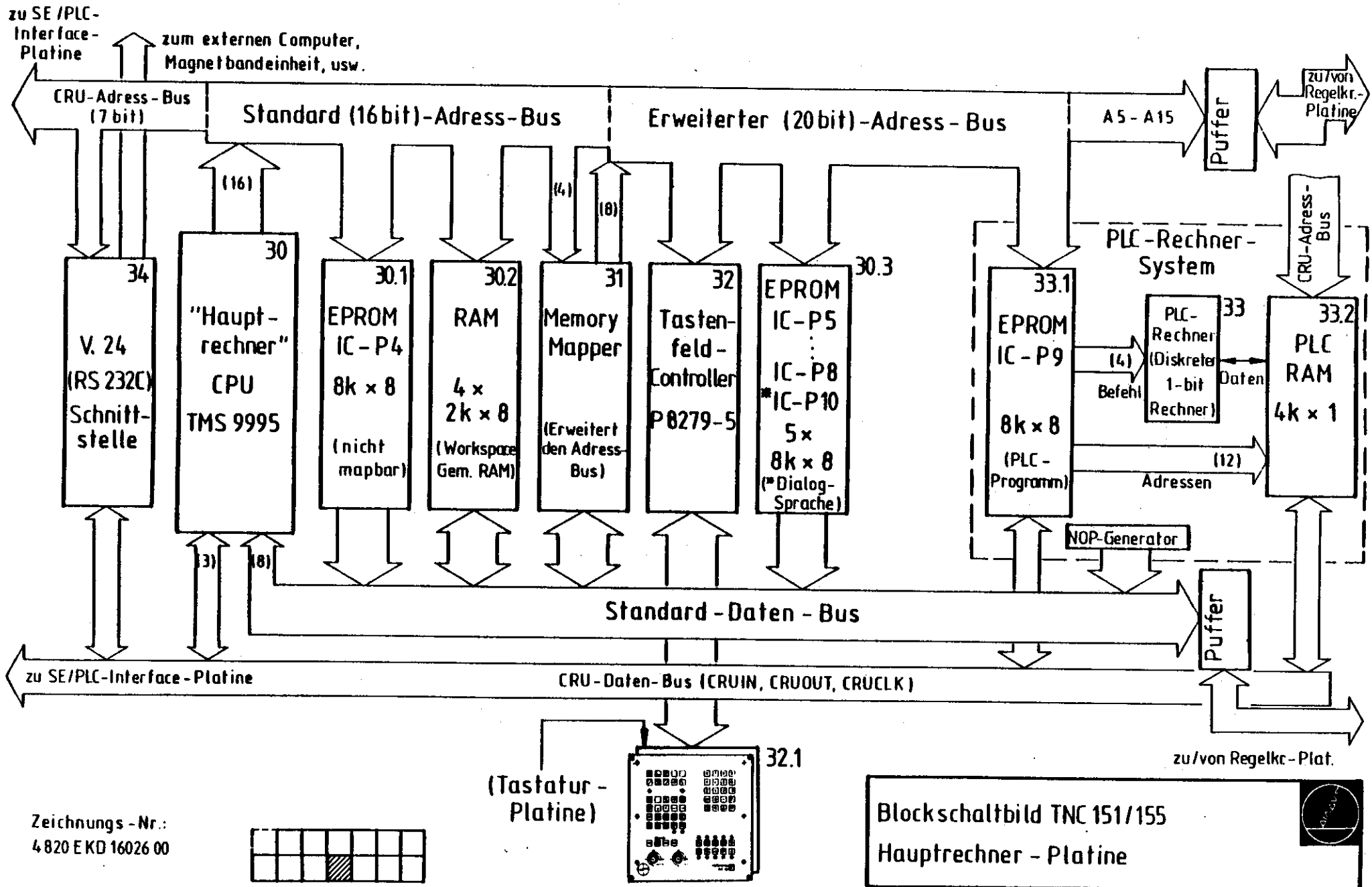

Zeichnungs-Nr.:
4 820 E KD 16026 00

Blockschaltbild TNC 151/155
Hauptrechner - Platine

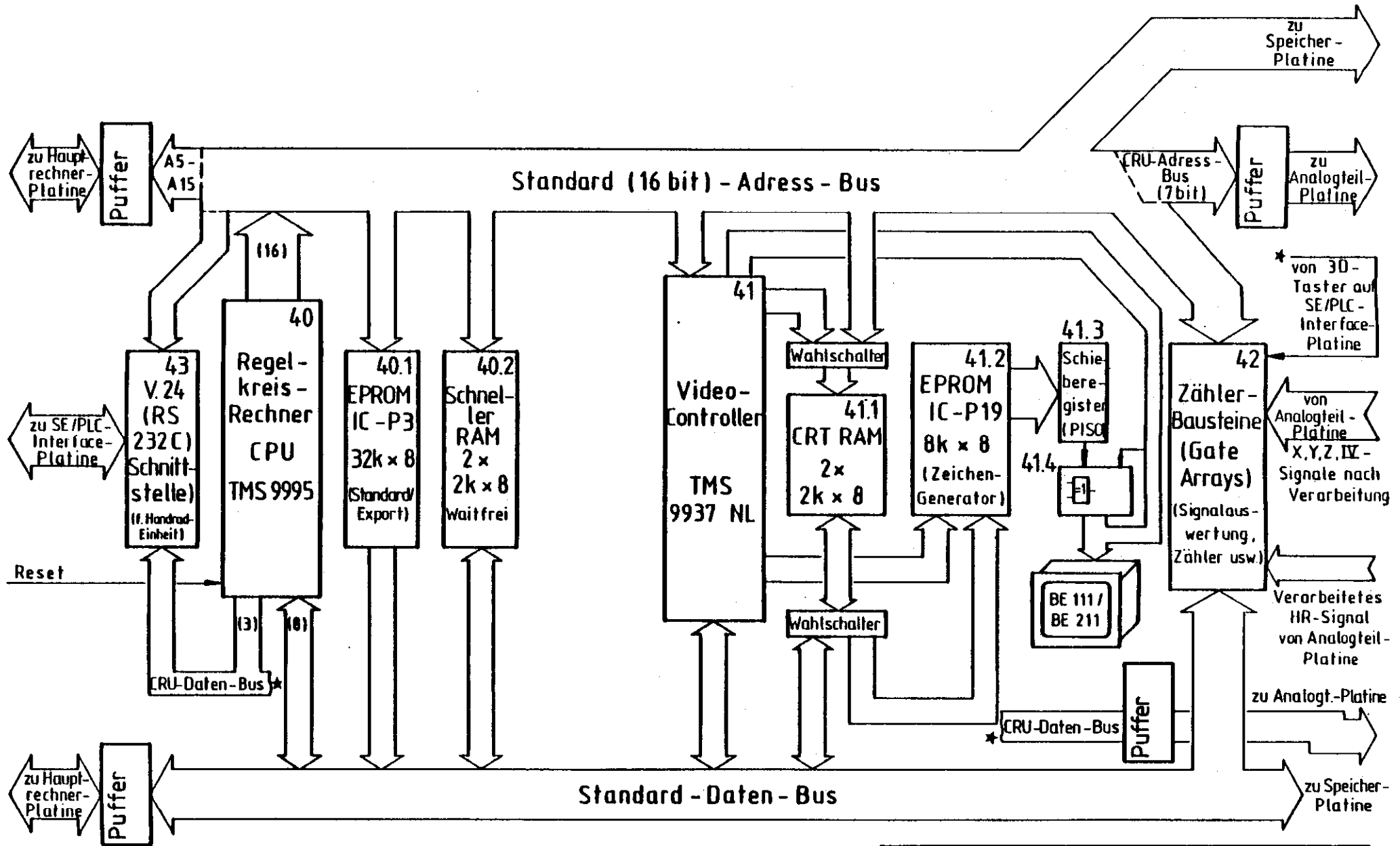

Blockschaltbild TNC 151
Regelkreis - Rechner - Platine

Zeichnungs - Nr.:
4 820 E KD 16029 00



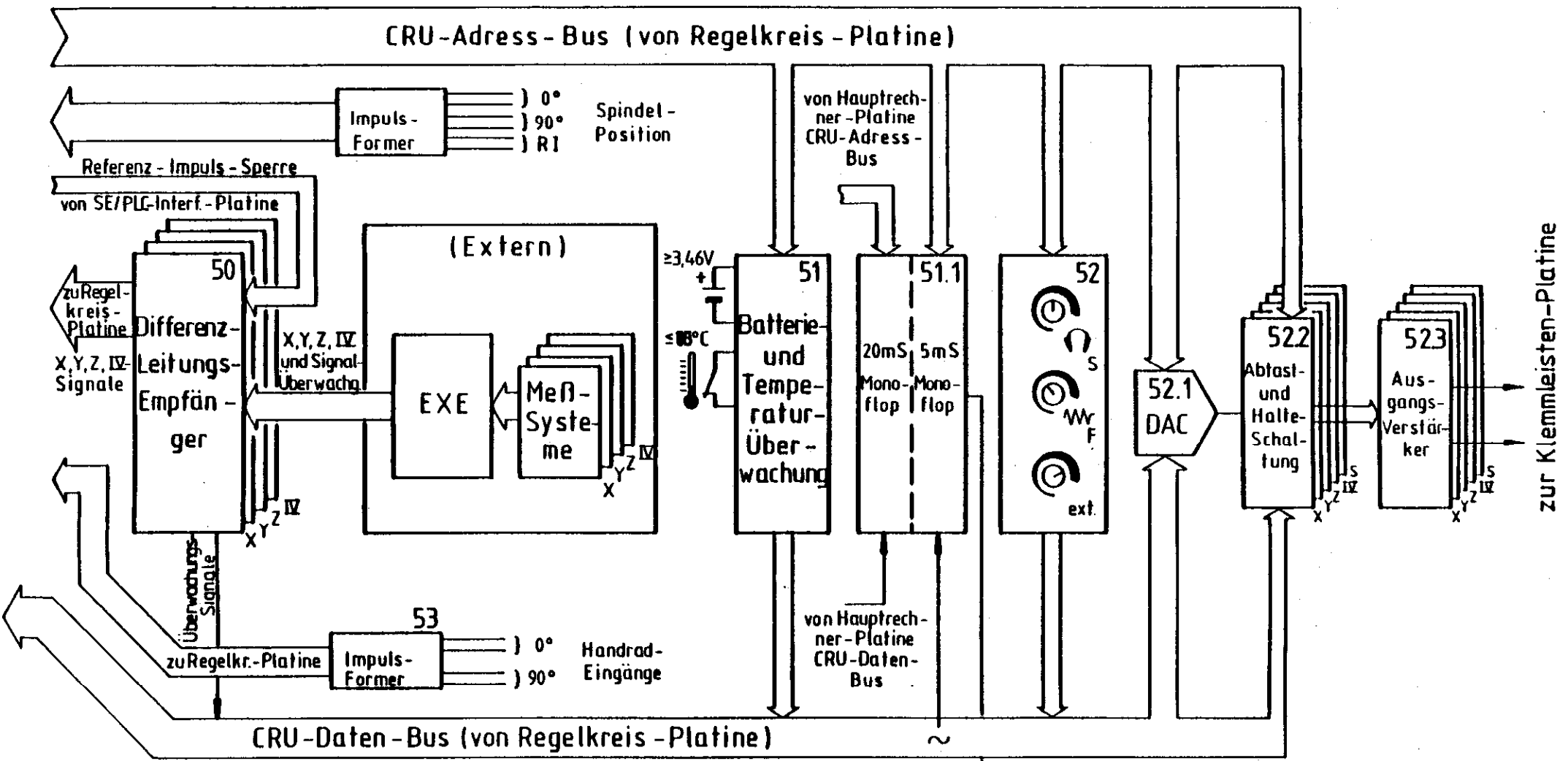

Zeichnungs - Nr.:
4820 EKD 16028 00



Blockschaltbild TNC 151/155
Analogteil - Platine (TTL-Eingänge)



CRU-Adress-Bus (von Regelkreis-Platine)

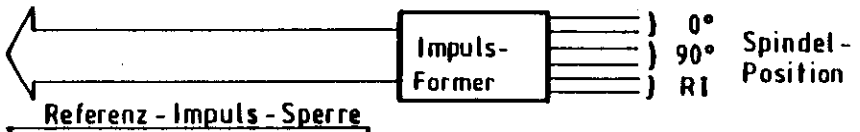

Referenz-Impuls-Sperre
von SE/PLC-Interf.-Platine

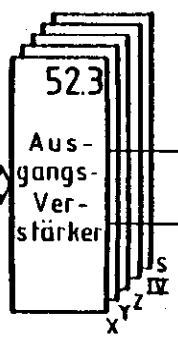
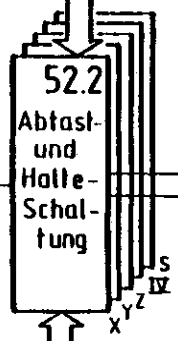
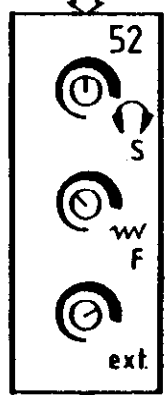
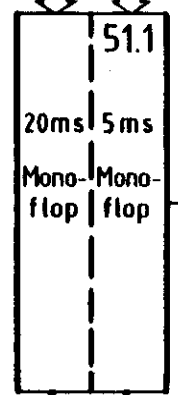
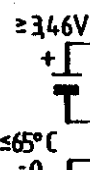
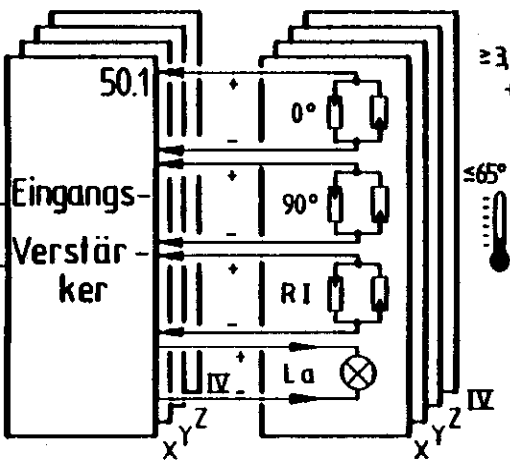
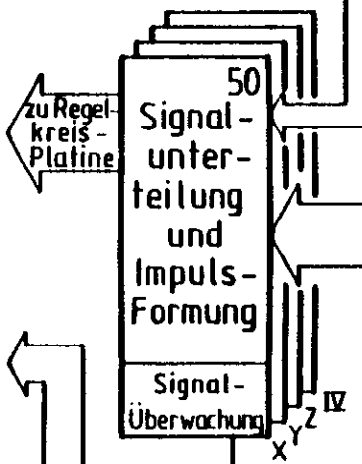

zur Klemmleiste-Platine



CRU-Daten-Bus (von Regelkreis-Platine)

von Hauptrechner-Platine
CRU-Daten-Bus

NOT
AUS

Blockschaltbild TNC 151/155
Analogteil-Platine

Zeichnungs-Nr.:
4.820 E KD 16027 00

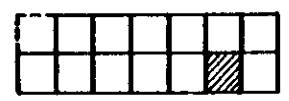

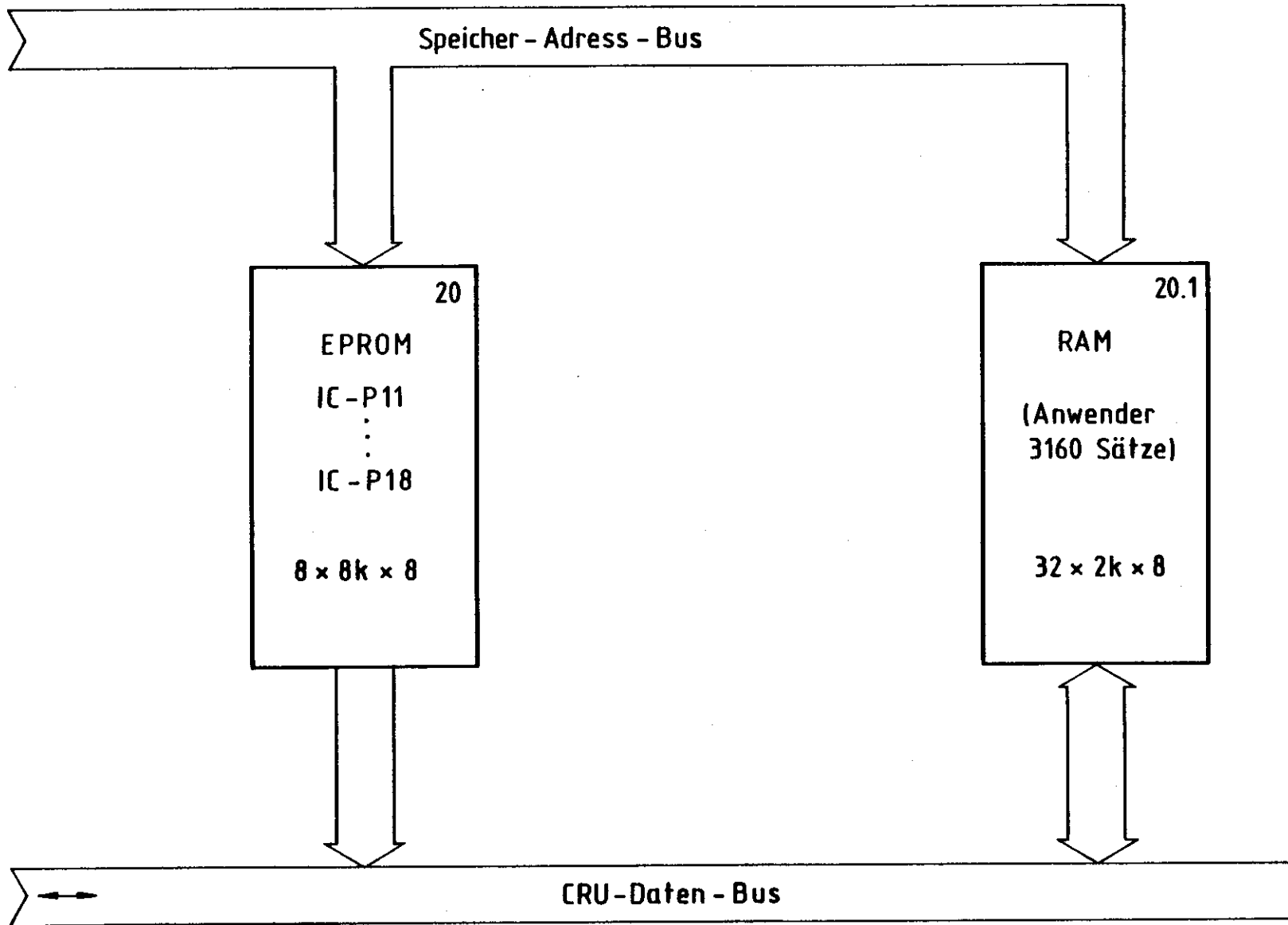

Zeichnungs - Nr:
4820 E KD1603100



Blockschaltbild TNC 151/155
Speicher - Platine



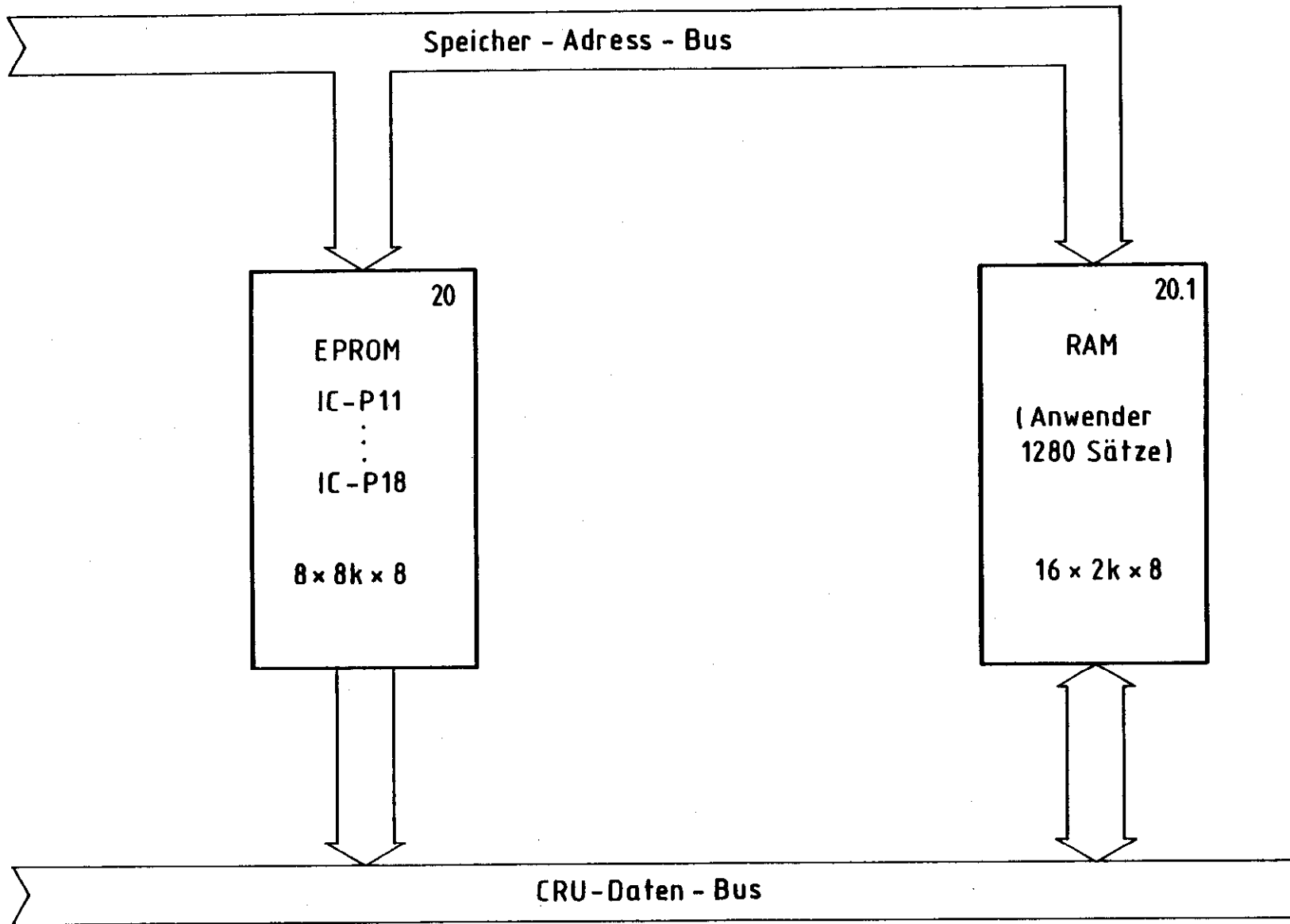

Zeichnungs - Nr.:
4820 EKD 16032 00



Blockschaltbild TNC 151
Speicher - Platine





Kundendienst

4.3 Wiring diagrams

Wiring diagram	TNC 155 A/E	Drawing No. 226 737 00	P. 71
Wiring diagram	TNC 155 AR/ER	Drawing No. 226 751 00	P. 72
Wiring diagram	TNC 155 P/V	Drawing No. 226 744 00	P. 73
Wiring diagram	TNC 155 PR/VR	Drawing No. 226 749 00	P. 74

Kundendienst

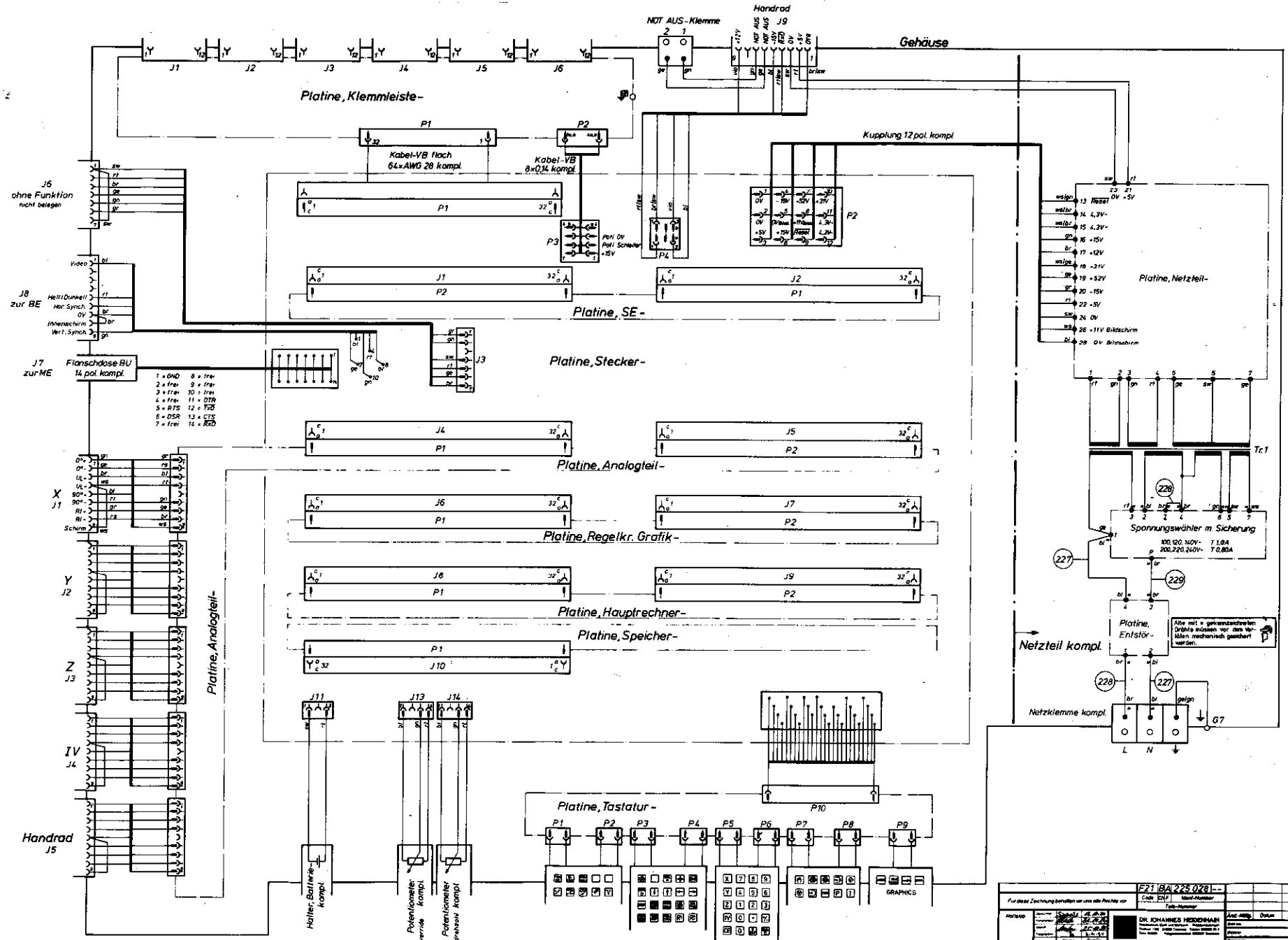

Kundendienst

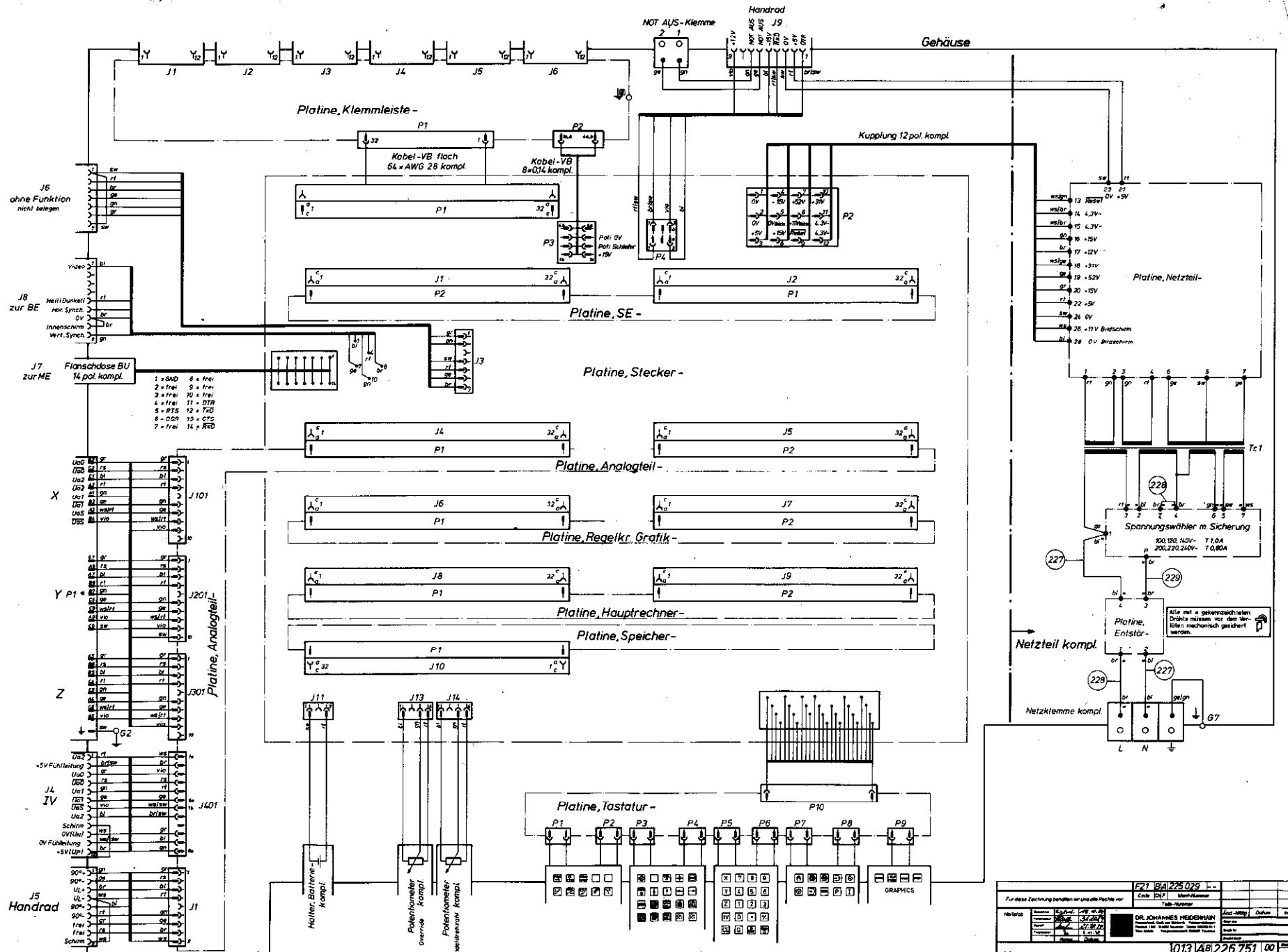

F21 BA225079		Code DNF		Ident-Nummer	
Für diese Zeichnung gelten nur die Maße vor					
Maßstab	1:1	Gezeichnet	27.07.79	Geprüft	
DR. JOHANNES HEIDENHAIN Messwerkzeuge mit dieser Kennzeichnung sind nach DIN 8582 geprüfte Messwerkzeuge. Die Genauigkeit ist in der Tabelle angegeben.					
Verdichtungsplan					
013 AB 226 751 00					

Kundendienst

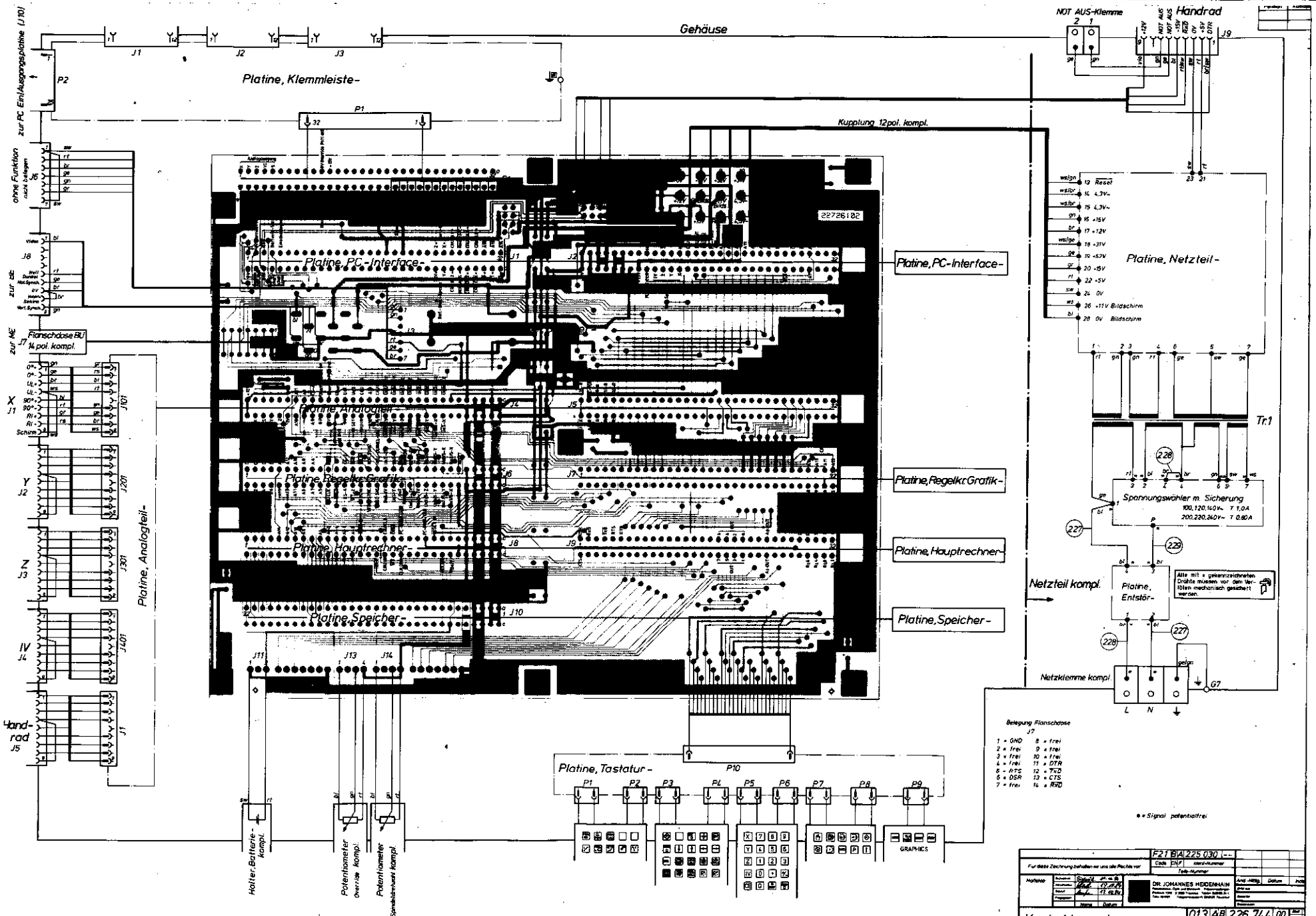

F21 BA 225 030		Blatt-Nr.		Blatt-Nr.	
Für diese Zeichnung behalten wir uns alle Rechte vor		Cock. DNF		Blatt-Nr.	
Autoren:		Gezeichnet:		Geprüft:	
Datum:		Datum:		Datum:	
Name:		Name:		Name:	
Firma:		Firma:		Firma:	
Vertragsnummer:		Vertragsnummer:		Vertragsnummer:	

Kundendienst

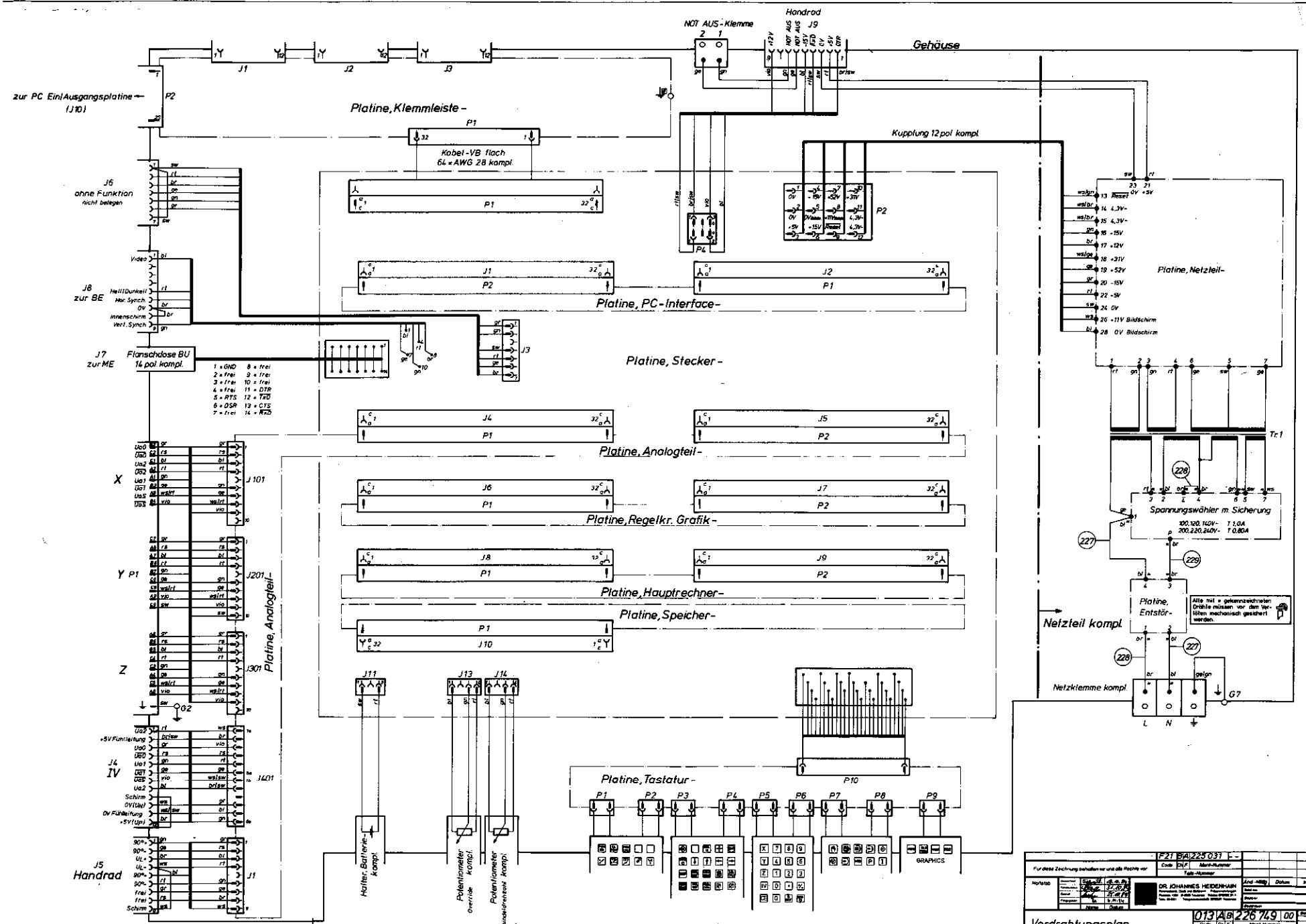

Für diese Zeichnung behält sich alle Rechte vor		Ecke: EN17 Maßstab: 1:1	
Verdrahtungsplan		0131A0226/9 00	
DR. JOHANNES HEIDENHAIN		Datei: EN17	



Kundendienst

4.4 Machine Parameters

Function	Parameter No.	Entry values
Rapid traverse X Y Z IV	0 1 2 3	80 – 15 999 mm/min
Manual feed X Y Z IV	4 5 6 7	(IV: Degrees/min. with axis designation A or B or C)
Speed when approaching reference points X Y Z IV	8 9 10 11	
Signal evaluation X Y Z IV	12 13 14 15	1 = 20-fold 2 = 10-fold
Traversing direction when approaching reference marks X Y Z IV	16 17 18 19	0 = Plus-direction 1 = Minus-direction (with correct programming of parameters Nos. 20 to 27)
Counting direction X Y Z IV	20 21 22 23	0 or 1
Polarity of nominal value voltage X Y Z IV	24 25 26 27	0 = positive with positive traversing direction 1 = negative with positive traversing direction
Integral factor X Y Z IV	28 29 30 31	0 – 65 535
Differential factor X Y Z IV	32 33 34 35	0 – 65,535 (Values from table on section 6.2.2)
Backlash compensation X Y Z IV	36 37 38 39	- 1.000 mm – + 1.000 mm
Correction factor for linear correction X Y Z IV	40 41 42 43	- 1.000 mm/m – + 1.000 mm/m

Function	Parameter No.	Entry values
Software limit switch ranges X+ X- Y+ Y- Z+ Z- IV+ IV-	44 45 46 47 48 49 50 51	0 to ± 30 000,000 mm Angular axis 0 to ± 30 000°
Analogue voltage with rapid traverse	52	+4,5 – +9 Volts
Approach speed	53	0,1 – 10 m/min
Acceleration	54	0,001 – 1,5 m/s ²
Circular acceleration	55	
Position supervision (erasable)	56	0,001 – 30 mm
Position supervision (emergency stop)	57	
Position window X, Y, Z	58	0,001 – 0,05 mm
Axis sequence for reference point approach	59	0 = X Y Z IV 12 = Z X Y IV 1 = X Y IV Z 13 = Z X IV Y 2 = X Z Y IV 14 = Z Y X IV 3 = X Z IV Y 15 = Z Y IV X 4 = X IV Y Z 16 = Z IV X Y 5 = X IV Z Y 17 = Z IV Y X 6 = Y X Z IV 18 = IV X Y Z 7 = Y X IV Z 19 = IV X Z Y 8 = Y Z X IV 20 = IV Y X Z 9 = Y Z IV X 21 = IV Y Z X 10 = Y IV X Z 22 = IV Z X Y 11 = Y IV Z X 23 = IV Z Y X
Speed pre-control	60	0 = on 1 = off
Output of tool numbers	61	0 No output 1 Output only when tool number changes 2 Output of tool number with every tool call
Output of spindle speeds codes or as S-analogue voltage	62	0 = No output of spindle rpm 1 = Coded output only when rpm changes 2 = Coded output of all rpms 3 = S-Analogue voltage output Gear switching signal only when gear ratio changes 4 = S-Analogue voltage output, Output of gear switching signal with every tool call 5 = S-Analogue voltage output without gear switching signal
rpm code limit	63	01991
Oscillation: when accelerating	64	0,01 – 0,999
Display resolution	65	0 = 1 µm 1 = 5 µm
External feed rate potentiometer	66	0 = internal potentiometer for override and manual feed 1 = external potentiometer for override and manual feed 2 = internal potentiometer for override external potentiometer for manual feed
Dwell time, rotation change of spindle in tapping cycle	67	0 – 65,535 s

Kundendienst

Function	Parameter No.	Entry values
Memory function for direction buttons	68	0 # off 1 # on
Special procedure for reference point	69	0 # off 1 # on
Nominal value voltage for spindle drive when tapping	70	0 - 9.999 Volts
Program end character	71	1 - 126 (depending on value of appropriate character on tape)
Selection for control of inhibited axes	72	0 # none Axis inhibited
	1 # X-	" "
	2 # Y-	" "
	3 # X-, Y-	" "
	4 # Z-	" "
	5 # X-, Z-	" "
	6 # Y-, Z-	" "
	7 # X-, Y-, Z-	" "
	8 # IV-	" "
	9 # X-, IV-	" "
	10 # Y-, IV-	" "
	11 # X-, Y-, IV-	" "
	12 # Z-, IV-	" "
	13 # X-, Z-, IV-	" "
	14 # Y-, Z-, IV-	" "
15 # X-, Y-, Z-, IV-	" "	
Pre-cut out time for tapping cycle	73	0 - 65.535 s
Override effective on pressing rapid button	74	0 # Override ineffective 1 # Override effective
Reference signal evaluation for inhibited axes	75	0 # inactive 1 # active
Display and transducer supervision for inhibited axes	76	0 # inactive 1 # active
PLC program from RAM or from EPROM	77	0 1
RPM-range gear ratios		
S-analogue output	78	0 - 9 000.000 rpm
	79	
	80	
	81	
	82	
	83	
	84	
	85	
S-Analogue voltage with S-Override at 100 %	86	0 - 9.999 Volts
S-Analogue voltage with S-Override at max. output voltage	87	
Limitation of S-override		0 - 150 %
Maximum	88	
Minimum	89	
Axis designation for axis IV	90	0 # A 3 # U 1 # B 4 # V 2 # C 5 # W
Constant contouring speed at corners	91	0 - 179.999 Angles in degrees
Decimal character in program output via V.24	92	0 # Decimal comma 1 # Decimal point
Overlapping factor with pocket milling	93	0.001 - 1.414

Function	Parameter No.	Entry values
PLC: Counter predetermined value for counter 0 - 15	94 to 109	0 - 65.535 in units of 20 ms
PLC: Timer duration for timer 0 - 15	110 to 125	0 - 65.535 in units of 20 ms
PLC: Position values for 31 coordinates 31 = Ref.	126 to 156	± 30 000.000 mm
Activation of next tool No.	157	0 # No output of next tool number 1 # Output only with change of tool number 2 # Output of next tool No. with every tool call
Setting of 16 markers to binary number	158	0 - 65.535
Automatic lubrication to programmed traversing distance in	159 to 162	0 - 65.535 (in 65.536-µm-units)
Feed rate for parameters Nos. 126 to 156	X	80 - 15 999 mm/min
	Y	
	Z	
	IV	
Display of current feed rate before start in	167	0 # off 1 # on
MANUAL OPERATION mode (same feed rate in all axes)		
Ramp gradient for S-analogue	168	0 - 1.999 Volts/ms
Standstill supervision	169	0.001 to 30 mm
Programming station	170	0 # Control 1 # Programming station: PLC active 2 # Programming station: PLC inactive
Handwheel	171	not yet active, enter 0
Polarity S-analogue voltage	172	0 # M 03: positive voltage M 04: negative voltage 1 # M 03: negative voltage M 04: positive voltage 2 # M 03 and M 04: positive voltage 3 # M 03 and M 04: negative voltage
Cancellation of status display with M 02 and M 30	173	0 # Status display not to be cancelled 1 # Status display to be cancelled
Trailing error supervision in trailing operation		
Emergency stop	174	0 - 100 mm
erasable	175	
Multiplication factor for K _V -factor	176	0.001 - 1.000
K _V -factor for	X	0.100 - 10.000
	Y	
	Z	
	IV	
Characteristic kink	181	0 - 100.000 %
Minimum for feed rate override with tapping	182	0 - 150 %
Maximum for feed rate override with tapping	183	
Minimum voltage for S-analogue output	184	0 - 9.999 Volts
Waiting time for cut-out of remaining nominal value voltage with error display "Positioning error"	185	0 - 65.535 s

Kundendienst

Function	Parameter No.	Entry values
Tool change position M 92:		
X-Axis	186	± 30 000.000
Y-Axis	187	
Z-Axis	188	
IV-Axis	189	
Programming of rpm S = 0 permitted (voltage value of MP 184 may be exceeded)	190	0 \neq S = 0 permitted 1 \neq S = 0 not permitted
Display of current spindle rpm before start in MANUAL OPERATION mode	191	0 \neq no display 1 \neq display
Position window for axis IV	192	0,001 – 0,05 mm
PLC: Timer duration for timer 16 – 31	193 to 208	0 – 65 535 in units of 20 ms
Support of PLC-macro commands	209 to 212	0
"Scaling" cycle effective for 2 or 3 axes	213	0 \neq the programmed scaling factor is effective in the 3 main axes X, Y, Z 1 \neq the programmed scaling factor is only effective in the working plane
Programmed stop with M 06	214	0 \neq Programmed stop with M 06 1 \neq No programmed stop with M 06

Function	Parameter No.	Entry values
Reserved machine parameter	215	Temporarily unassigned, enter 00
Reserved machine parameter	216	Temporarily unassigned, enter 0
Programming language changeover, HEIDENHAIN-dialogue/ISO format	217	0 \neq Program entry in HEIDENHAIN-dialogue 1 \neq Program entry in ISO-format
Parameters for definition of the V.24-(RS-232-C) interface	218 219 221 222	0 \neq 65535 0 \neq 65535 0 \neq 65535 0 \neq 65535
Standard data interface or "Transfer blockwise"	223	0 \neq standard data interface 1 \neq "Transfer blockwise"
Parameter for definition of the V.24 (RS-232-C) interface (see	224	0 – 255
<u>The following machine parameters have been extended:</u>		
Function	Parameter No.	Entry values
Spare character for STX/STX	71	0 – 65535
Programmed stop with M 06 CYCL CALL possible with M 89	214	0 \neq Programmed stop with M 06 No CYCL CALL with M 89 1 \neq No programmed stop with M 06 No CYCL CALL with M 89 2 \neq Programmed stop with M 06 CYCL CALL with M 89 3 \neq No programmed stop with M 06 CYCL Call with M 89