



HEIDENHAIN



Montageanleitung
Mounting Instructions
Instructions de montage
Istruzioni di montaggio
Instrucciones de montaje

RCN 723
FANUC-Interface
(High resolution type)

12/2001



1.



2.

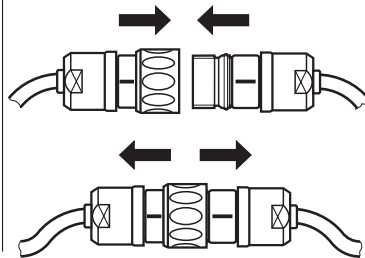

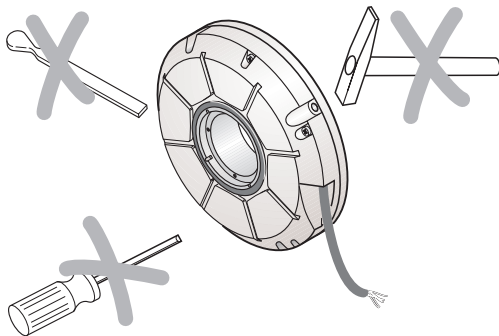
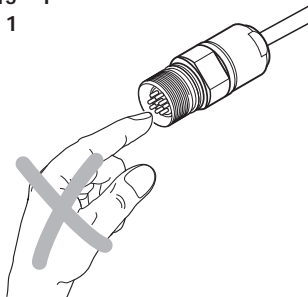
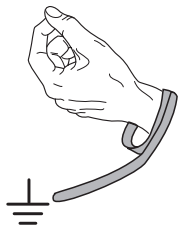

DIN EN 100 015 - 1
CECC 00015 - 1

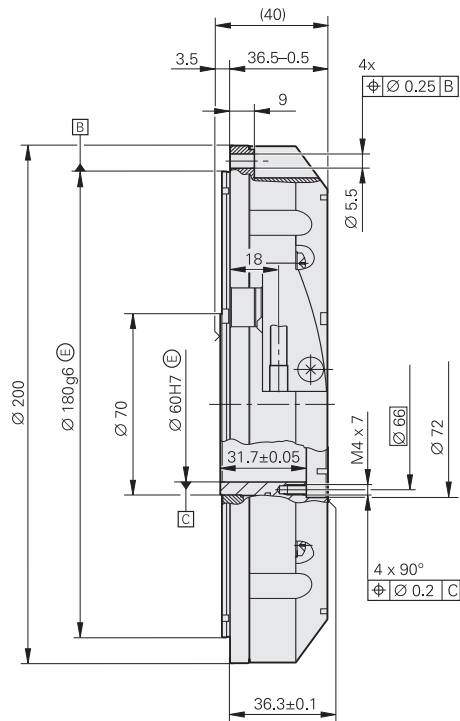

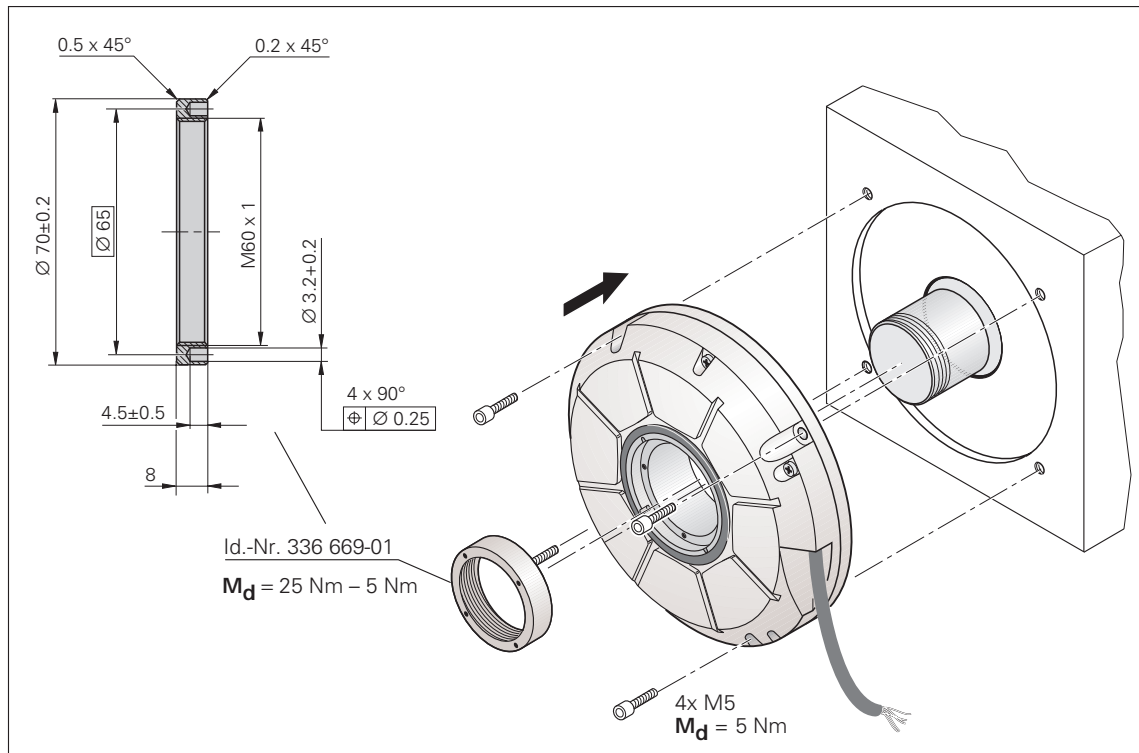

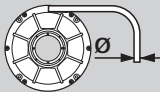
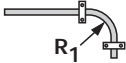
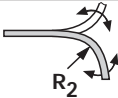

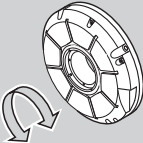

	 <p>$T \geq -40\text{ °C}$ (-40 °F)</p>	 <p>$T \geq -10\text{ °C}$ (14 °F)</p>
<p>$\text{Ø } 6\text{ mm}$</p>	<p>$R_1 \geq 20\text{ mm}$</p>	<p>$R_2 \geq 75\text{ mm}$</p>
<p>$\text{Ø } 8\text{ mm}$</p> 	<p>$R_1 \geq 40\text{ mm}$</p>	<p>$R_2 \geq 100\text{ mm}$</p>

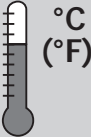
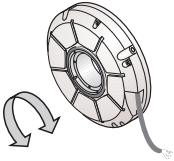
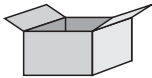
	<p>IP 64 EN 60529</p>
	<p>$M_d \leq 0.5\text{ Nm}$ (20 °C) $I = 1.2 \cdot 10^{-3}\text{ kgm}^2$</p>

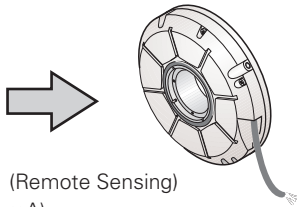
	 <p>0 ... 50 °C (32 ... 122 °F)</p>
	 <p>-30 ... 80 °C (-22 ... 176 °F)</p>



U_p = 5 V ± 5 % (Remote Sensing)
(max. 350 mA)



 EN 50 178/4.98; 5.2.9.5
IEC 364-4-41: 1992; 411(PELV/SELV)
(siehe, see, voir, vedi, véase
HEIDENHAIN D 231 929-01 -A-01)

 RS-485

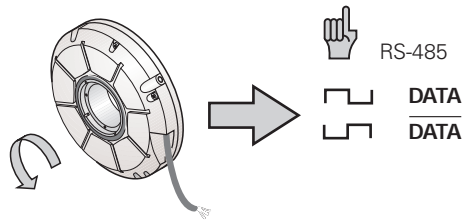
 **Request**
 **Request**



 RS-485

 **DATA**
 **DATA**

RS-485

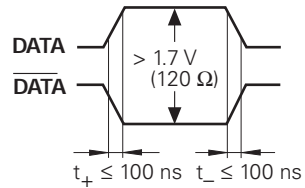

Id.-Nr. 291 698-26

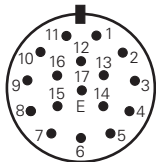
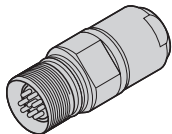

1) Außenschirm auf Gehäuse
External shield on housing
blindage externe sur boîtier
schermo esterno sulla carcassa
blindaje externo a carcasa

14	17	8	9	7	10	1)	1	4
DATA	DATA	Request	Request	5V U _P	0V U _N		5V sensor	0V sensor
grau <i>gray</i> gris <i>grigio</i> gris	rosa <i>pink</i> rose <i>rosa</i> rosa	violett <i>violet</i> violet <i>viola</i> violeta	gelb <i>yellow</i> jaune <i>giallo</i> amarillo	braun/grün <i>brown/green</i> brun/vert <i>marrone/verde</i> marrón/verde	weiß/grün <i>white/green</i> blanc/vert <i>bianco/verde</i> blanco/verde		blau <i>blue</i> bleu <i>azzurro</i> azul	weiß <i>white</i> blanc <i>bianco</i> blanco

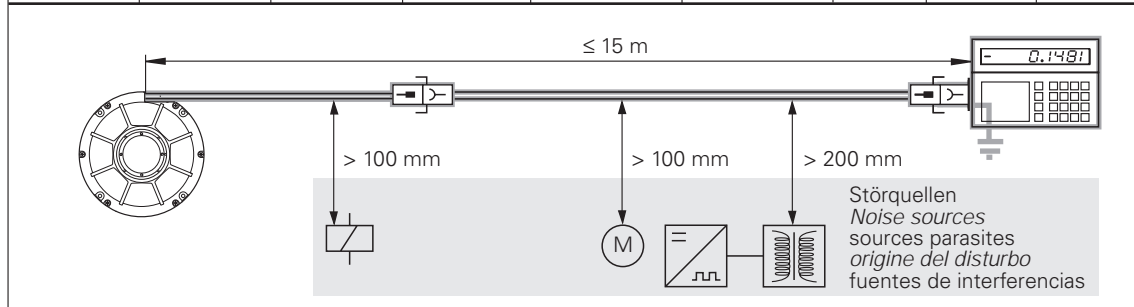

HEIDENHAIN

DR. JOHANNES HEIDENHAIN GmbH

Dr.-Johannes-Heidenhain-Straße 5

83301 Traunreut, Germany

☎ +49/8669/31-0

FAX +49/8669/5061

E-Mail: info@heidenhain.de

Technical support FAX +49/8669/31-1000

Measuring systems ☎ +49/8669/31-3104

E-Mail: service.ms-support@heidenhain.de

TNC support ☎ +49/8669/31-3101

E-Mail: service.nc-support@heidenhain.de

NC programming ☎ +49/8669/31-3103

E-Mail: service.nc-pgm@heidenhain.de

PLC programming ☎ +49/8669/31-3102

E-Mail: service.plc@heidenhain.de

Lathe controls ☎ +49/711952803-0

E-Mail: service.hsf@heidenhain.de

www.heidenhain.de

Ve 01

363 481-91 · 3 · 5/2003 · F&W · Printed in Germany

Änderungen vorbehalten · *Subject to change without notice* · Sous réserve de modifications · *Con riserva di modifiche* · Sujeto a modificaciones

