



HEIDENHAIN

Montageanleitung
Mounting Instructions
Instructions de montage
Istruzioni di montaggio
Instrucciones de montaje

LC 191 M
MITSUBISHI
High Speed Serial Interface

 DIN EN 100 015 - 1
CECC 00015 - 1

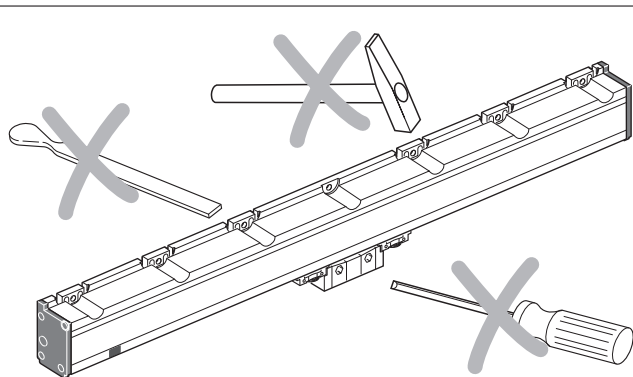
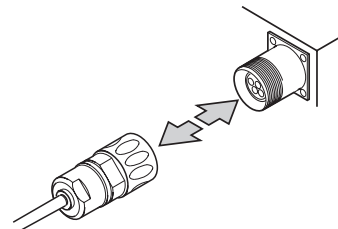
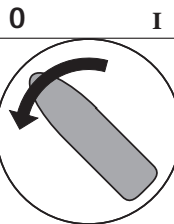

Maße in mm
Dimensions in mm
Cotes en mm
Dimensioni in mm
Dimensiones en mm



Die Inbetriebnahme des LC 191 M erfordert eine richtige Parametrierung der MITSUBISHI-Steuerung (Gefahr von Sach- und Personenschäden). Zur richtigen Parametrierung nehmen Sie bitte Kontakt zum Hersteller der Maschine auf.

The MITSUBISHI control parameters for the LC 191 M must be correctly configured for proper function. Improper configuration may result in damage to the equipment or even personal injury. Please contact the machine manufacture for the correct parameter configuration.

La mise en route du LC 191 M nécessite un paramétrage correct de la commande MITSUBISHI (risque matériels et corporels). Pour effectuer le paramétrage correctement, prenez S.V.P. contact avec le constructeur de la machine.

La messa in funzione della LC 191 M richiede una corretta parametrizzazione del controllo MITSUBISHI (rischio di danni alle cose e alle persone). Per una corretta parametrizzazione mettersi in contatto con il costruttore della macchina.

La puesta en marcha de la LC 191 M requiere una parametrización correcta del sistema de medida MITSUBISHI (peligro de daños en cosas y personas). Para la parametrización correcta contacten con el constructor de la máquina.

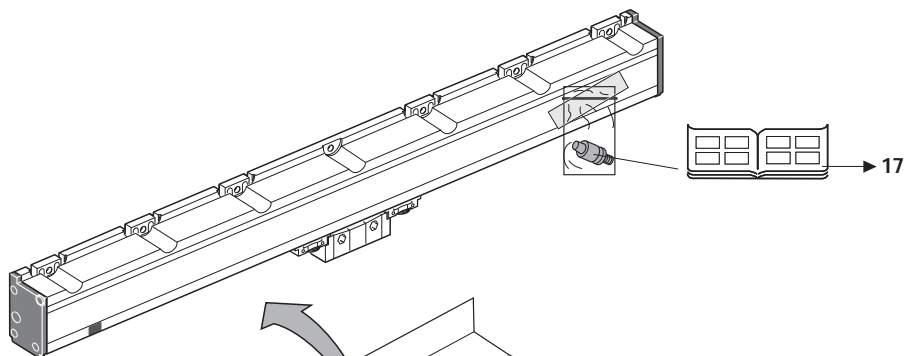

Separat bestellen
Order separately
A commander séparément
Ordinare a parte
Para pedir por separado

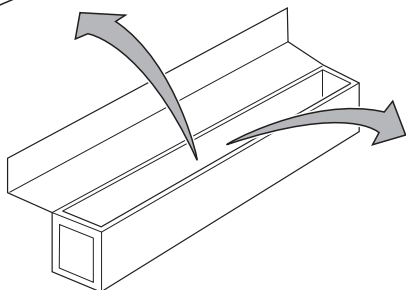
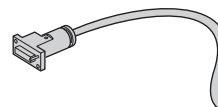

Bei Montage bitte Geräteschild-Aufkleber anbringen (Schaltschrank, Maschinen-Handbuch usw.)

Apply the encoder ID label to an appropriate surface, e.g. the electrical cabinet or machine manual

Lors du montage, accoler S.V.P. l'étiquette signalétique de l'appareil (armoire électrique, manuel de la machine, etc.)

Completato il montaggio, ricordarsi di applicare l'etichetta (manuale della macchina, quadro elettrico)

Por favor, durante el montaje, colocar el adhesivo del letrero del aparato (armario eléctrico, modo de empleo de la máquina, etc.)

1/4 Umdrehung lösen
Loosen by 1/4 revolution
Dévisser de 1/4 de tour
Allentare di 1/4 di giro
Aflojar 1/4 de vuelta

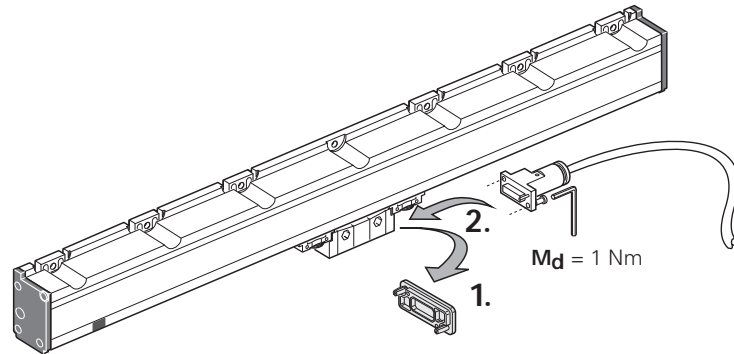
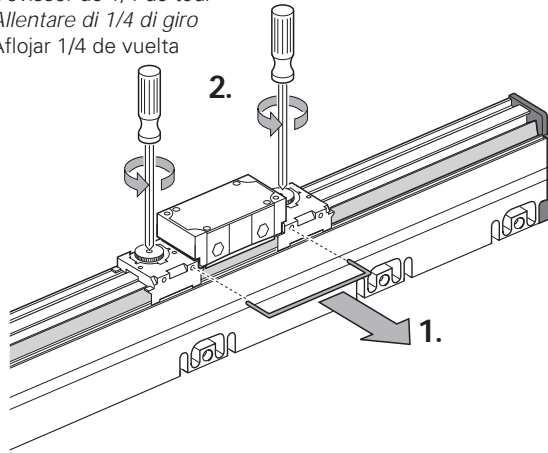

Hinweise zur Montage · *Mounting Procedure* · Procédures pour le montage

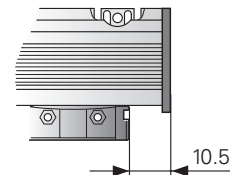
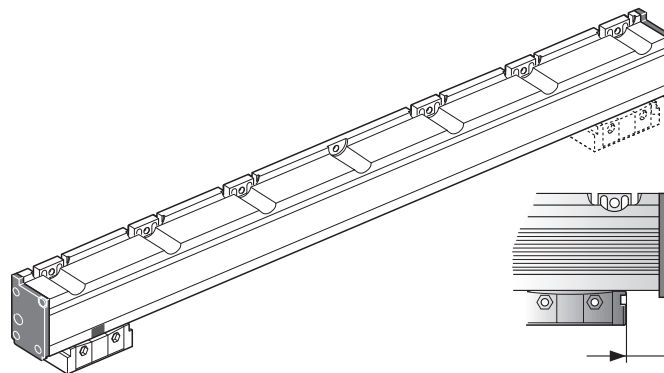
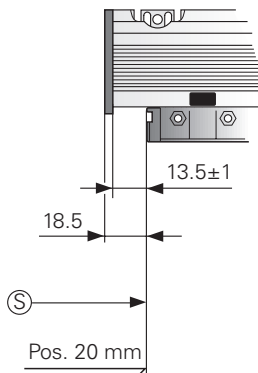

- Ⓢ= Der Absolutwert beim Beginn der Messlängen beträgt 20 mm. Je nach Auflösung errechnet sich der Positionswert.
At the beginning of the measuring lengths, the absolute value is 20 mm. The calculated position value depends on the resolution.
 La valeur absolue au début des longueurs de mesure est de 20 mm. La valeur de position est calculée en fonction de la résolution.
All'inizio della corsa utile, il valore assoluto della posizione è di 20 mm. Il calcolo del valore di posizione dipende dalla risoluzione.
 Al comienzo del curso útil, el valor absoluto es de 20 mm de los extremos. El valor de posición se calcula en función de la resolución.

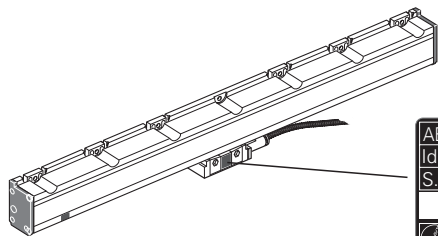

Messschritt z.B. 50 nm oder 0 = programmierbar für Service
 Measuring step e.g. 50 nm or 0 = programmable for Service
 Pas de mesure ex. 50 nm ou 0 = programmable pour SAV
 Passo di misura ad. es. 50 nm oppure 0 = programmabile per assistenza tecnica
 Paso de medición p.ej. 50 nm ó 0 = programable para servicio

Avvertenze per il montaggio · Indicaciones para el montaje

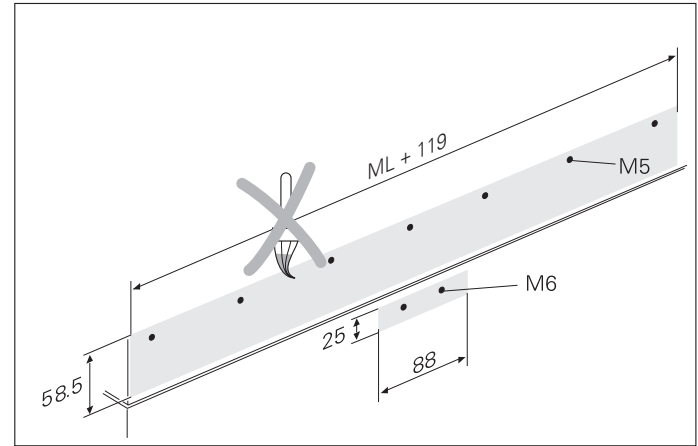
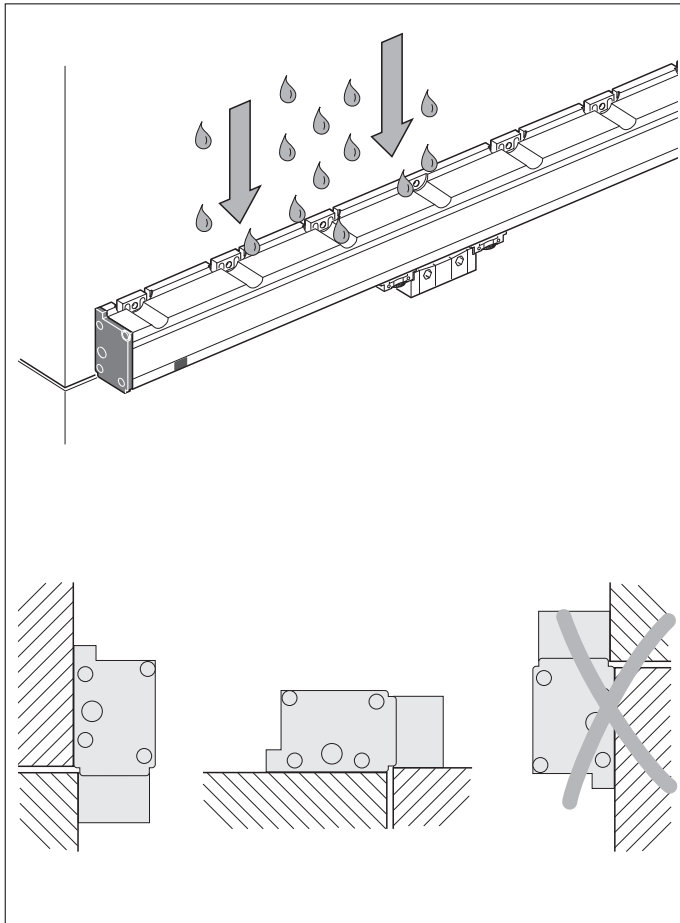

 DIN EN 100 015 - 1
CECC 00015 - 1

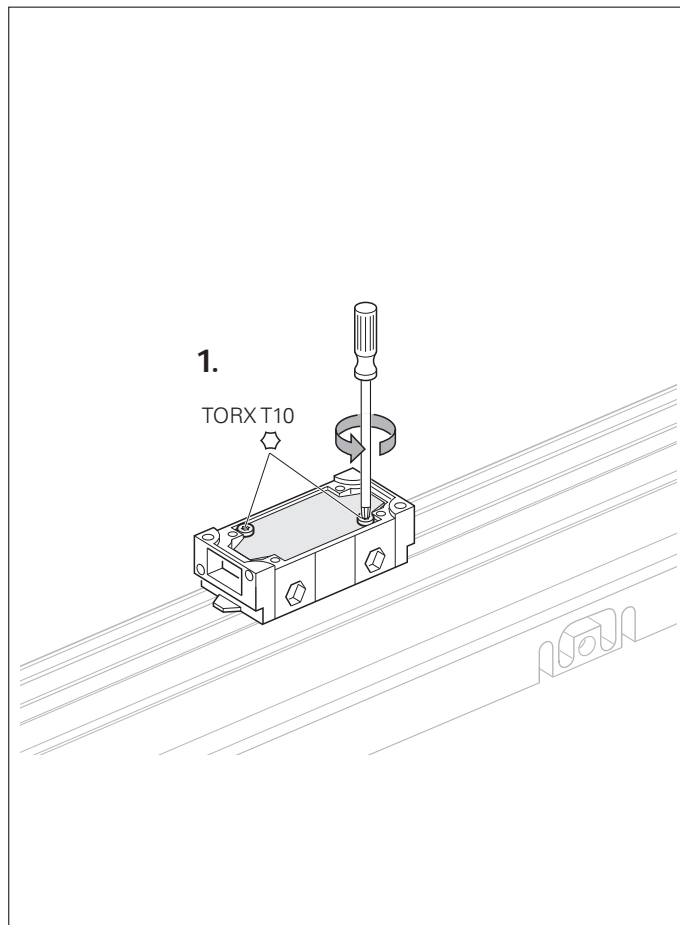
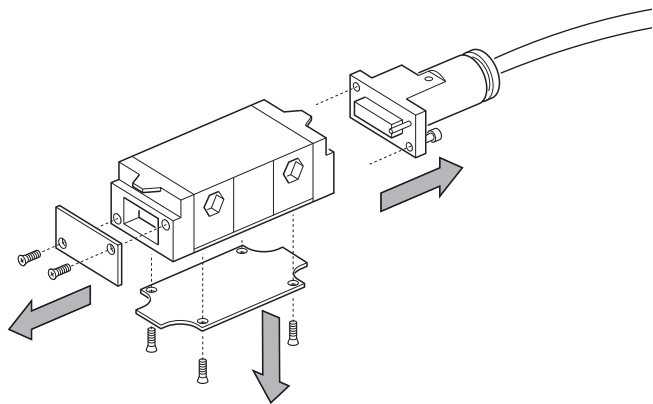
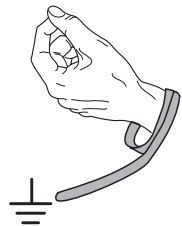

Configurazione dell'uscita del cavo · Colocar cable de salida

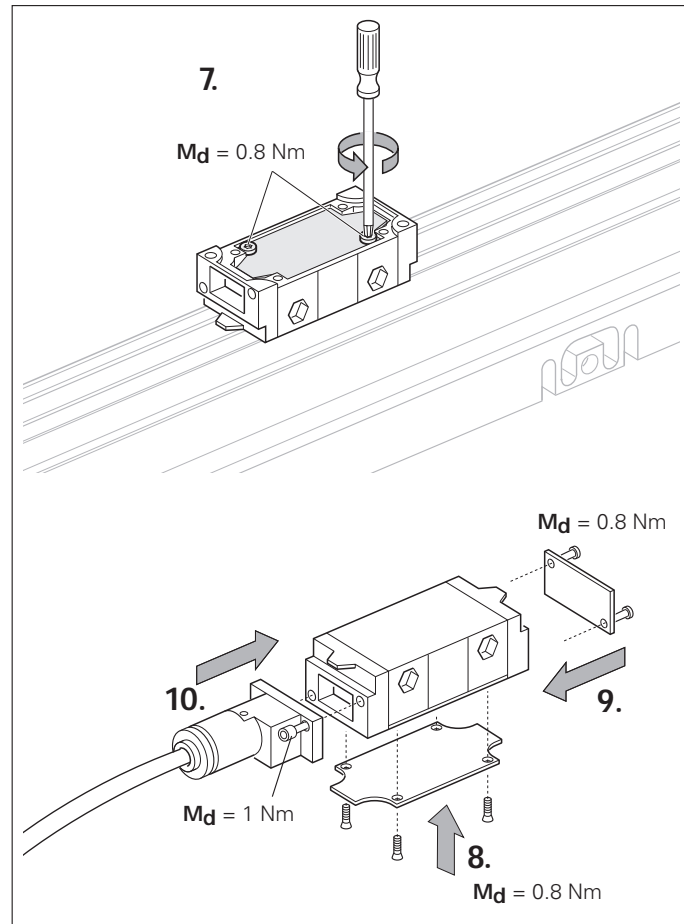
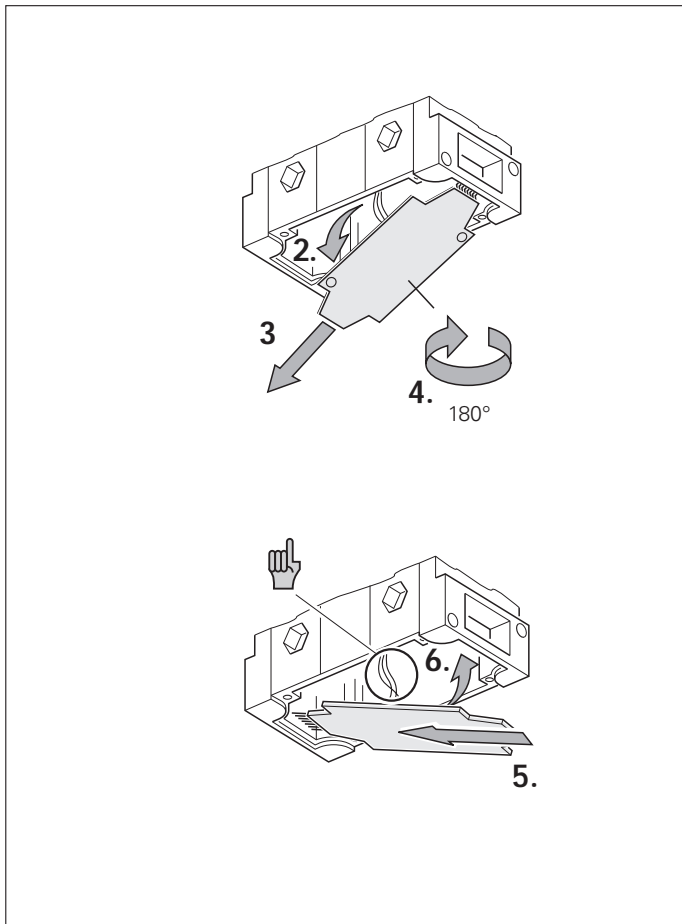

Abmessungen · Dimensions · Dimensions · Dimensioni · Dimensiones

mm



DIN ISO 8015
ISO 2768 - m H

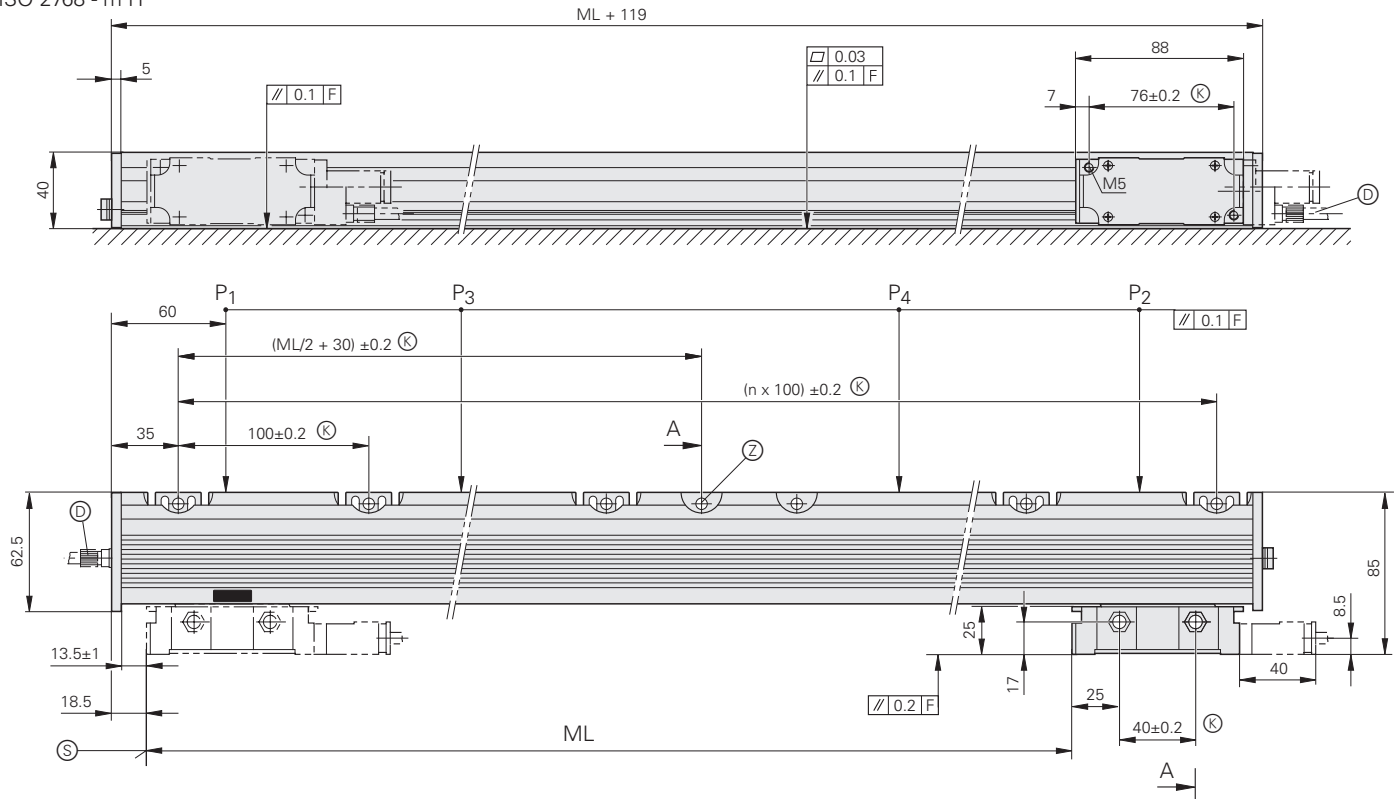

F = Maschinenführung
Machine guideway
 guidage de la machine
 guida della macchina
 guía de la máquina

① = Druckluftanschluss
Compressed air inlet
 raccordement d'air comprimé
 ingresso per pressurizzazione
 conexión de aire comprimido

② = erfüllt wenn $(ML/2 + 30)/100 =$ ganzzahlig
not applicable, if $(ML/2 + 30)/100$ is an integer
 inutile si $(ML/2 + 30)/100$ est un nombre entier
 non vale se $(ML/2+30)/100$ è un numero intero
 no es aplicable cuando $(ML/2 + 30)/100 =$ número entero

P = Messpunkte zum Ausrichten
Gauging points for alignment
 points de mesure pour dé gauchissage
 punti di misura per allineamento
 puntos medición alineamiento

③ = Beginn der Messlänge ML
Begin. of meas. length ML
 début longueur utile ML
 inizio lunghezza di misura ML
 comienzo longitud útil ML

Ⓚ = Kundenseitige Anschlussmaße
Required mating dimensions
 conditions requises pour le montage
 dimensioni di collegamento lato cliente
 cotas de montaje requeridas

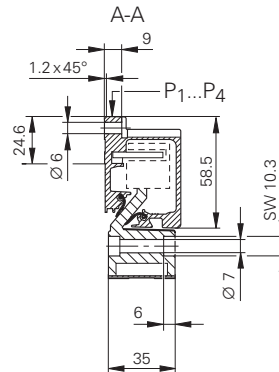
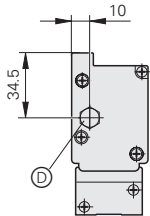

① ② ③ = Montage-Möglichkeiten
Mounting possibilities
 Options de montage
 Possibilità di montaggio
 Posibilidades de montaje

Ⓚ = Kundenseitige Anschlussmaße
Required mating dimensions
 Conditions requises pour le montage
 Dimensioni di collegamento lato cliente
 Cotas de montaje requeridas

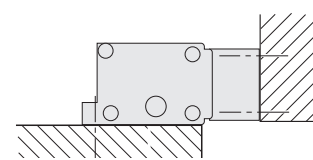
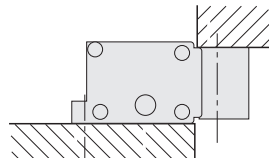
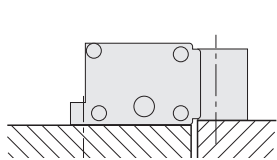
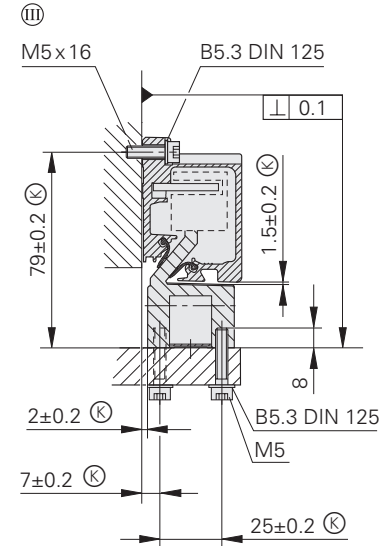
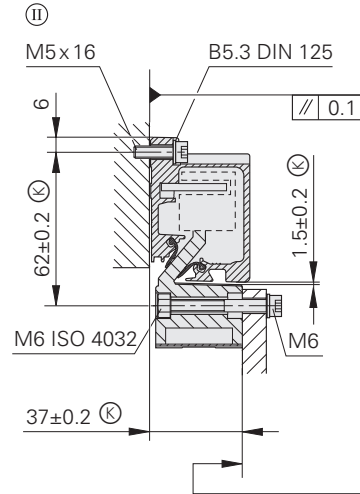
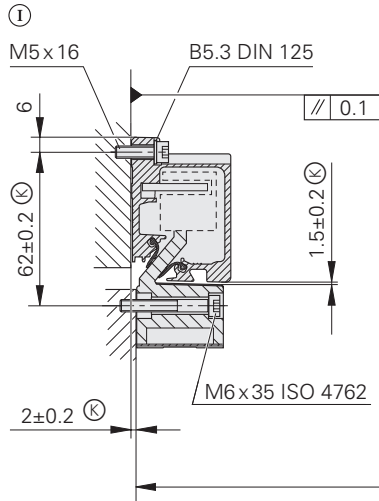

Anbau des Maßstabs · *Mounting the scale* · Montage de la règle de mesure · *Montaggio della riga* · Montaje de la regla

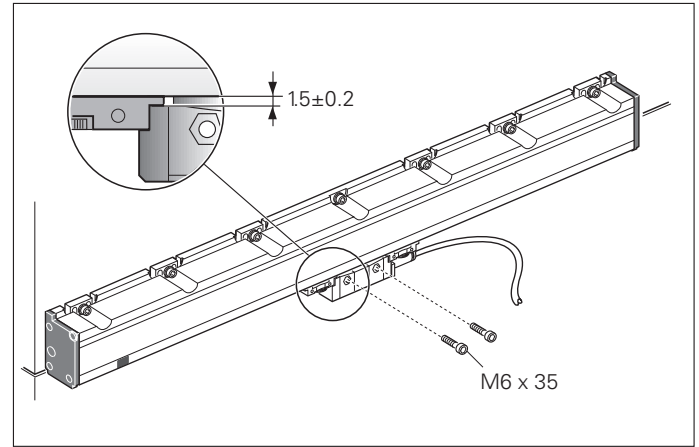
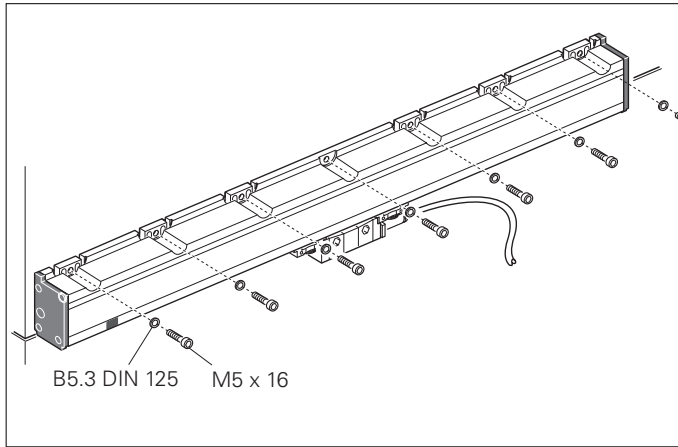

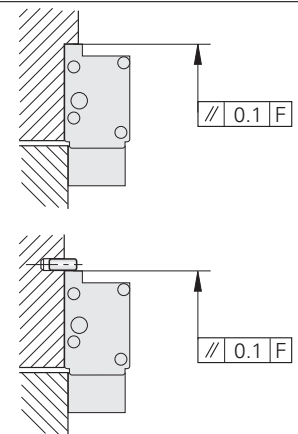
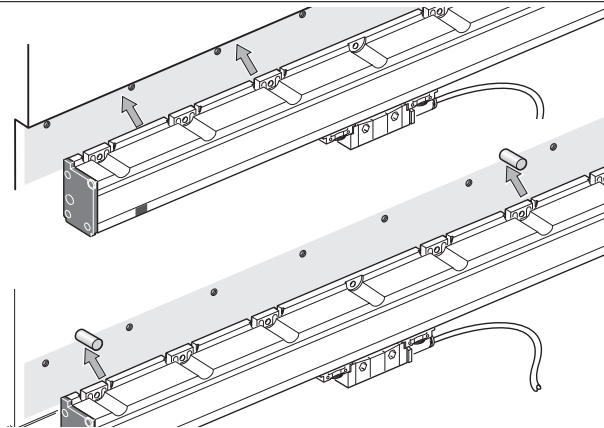

zusätzliche Anbaumöglichkeiten
Additional mounting options
 Possibilités de montage supplémentaires
Altre possibilità di montaggio
 Posibilidades de montaje adicionales

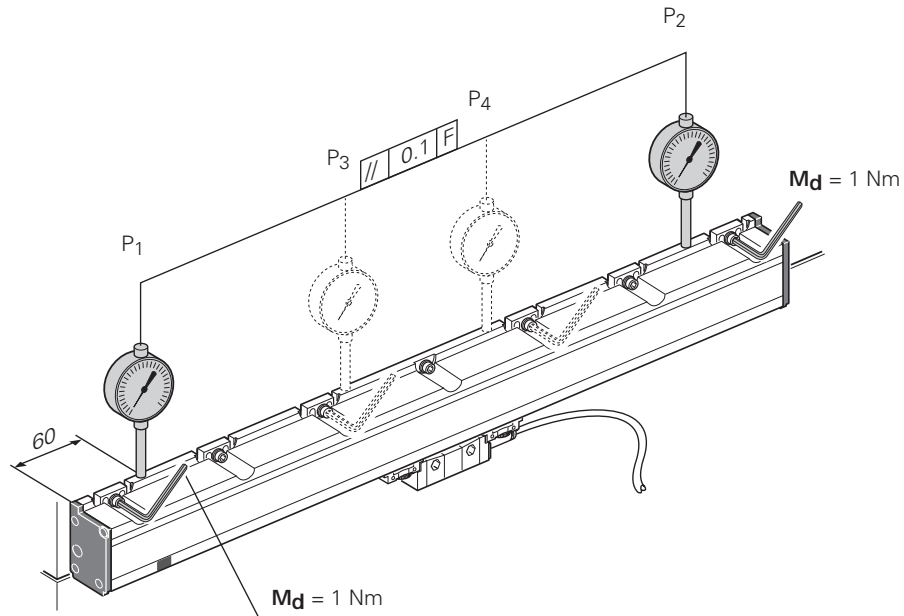

Ausrichten · Alignment · Alignement · Allineamento · Alinear

P = Messpunkte zum Ausrichten
Gauging points for alignment
 Points de mesure pour dé gauchissage
Punti di misura per allineamento
 Puntos medición alineamiento



ML	
≤ 840mm	2x
≤ 1740mm	3x
≤ 3040mm	4x

Befestigungsreihenfolge beachten
Mittlere Befestigung zwingend notwendig („Thermischer Fixpunkt“)

*Use the correct sequence when fastening
Mid-point must be fastened (“thermal fixpoint”)*

Respecter l'ordre chronologique de la fixation
Fixation centrale impérative („point fixe thermique“)

*Attenzione alla sequenza per il fissaggio
Il punto di fissaggio centrale è obbligatorio („punto di fissaggio termico“)*

Tener en cuenta la secuencia de sujeción
Sujeción central necesariamente obligatoria („Punto de fijación térmico“)

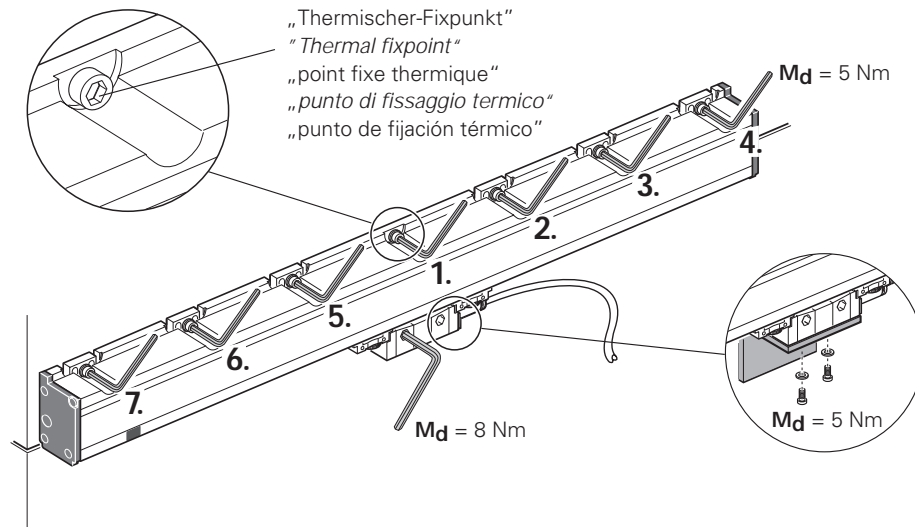

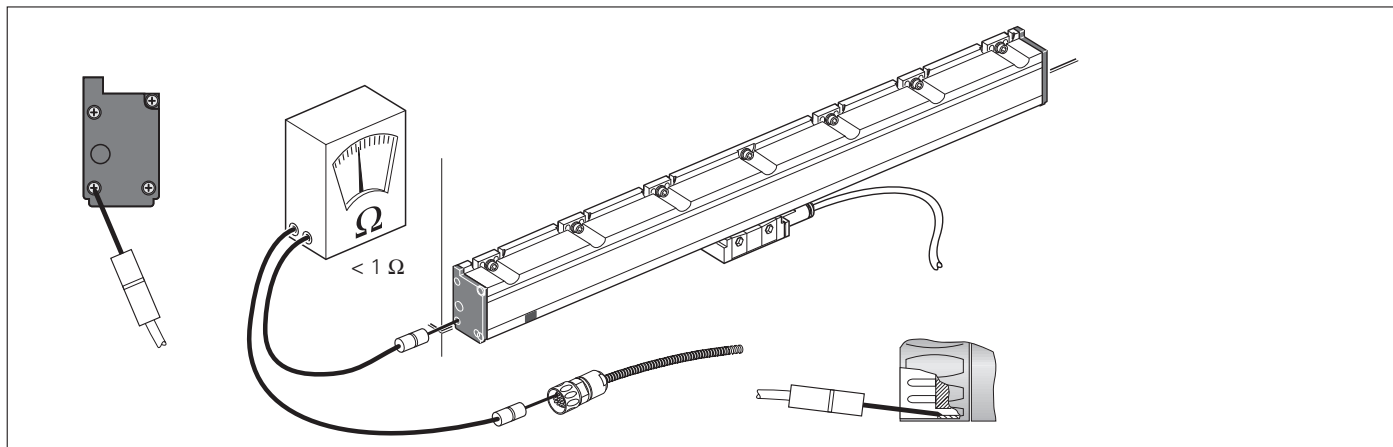
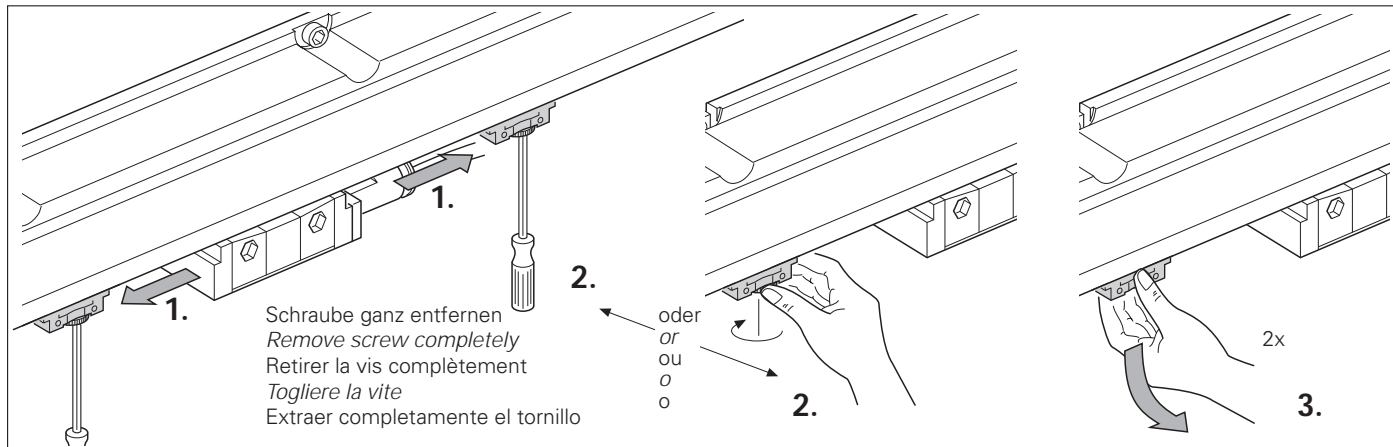

Abschließende Arbeiten · Final Steps · Opérations finales · Operazioni finali · Trabajos finales

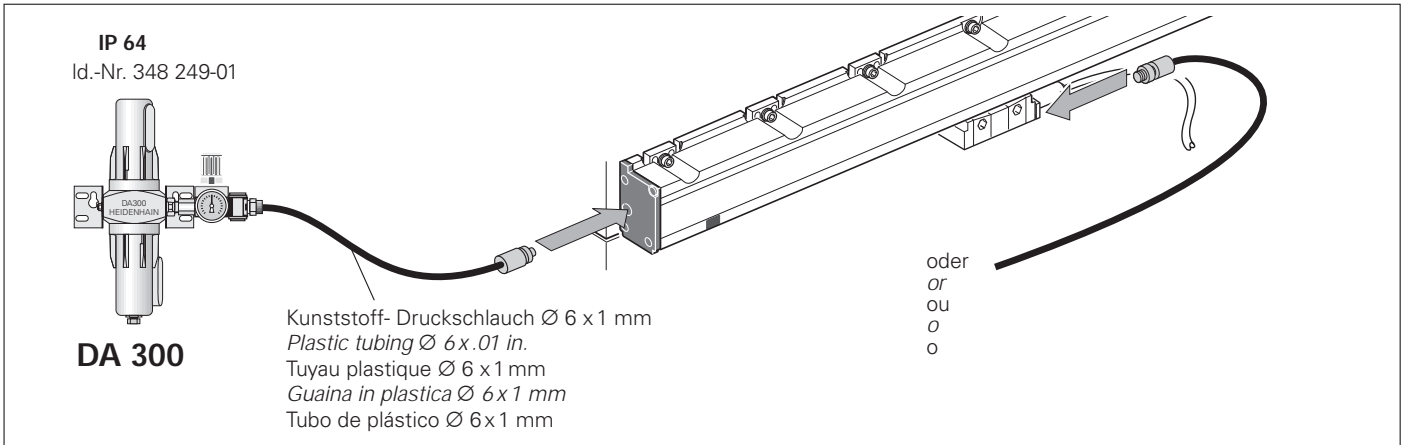
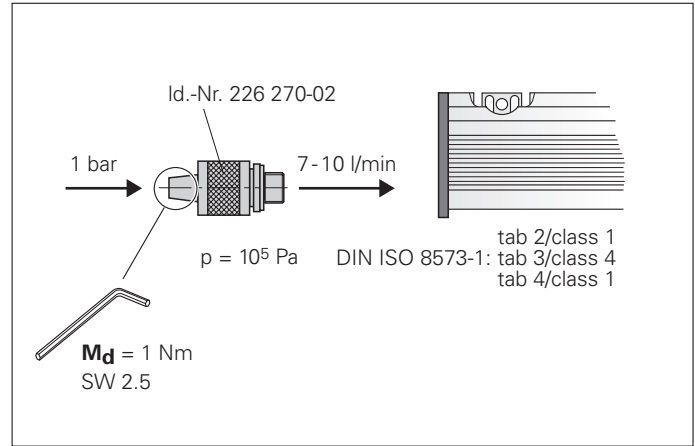
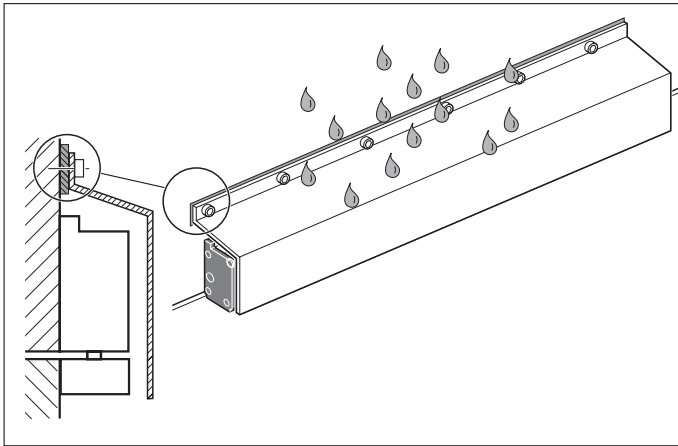

Schutzmaßnahmen · Protective Measures · Mesures préventives · Precauzioni · Medidas de protección

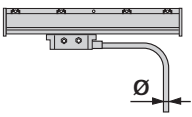
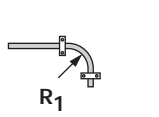
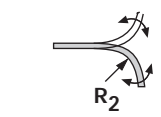

Technische Kennwerte · Specifications · Caractéristiques techniques · Dati tecnici · Datos técnicos

		
Ø 6 mm	$R_1 \geq 20 \text{ mm}$	$R_2 \geq 75 \text{ mm}$
Ø 10 mm	$R_1 \geq 35 \text{ mm}$	$R_2 \geq 75 \text{ mm}$
 Ø 8 mm	$R_1 \geq 40 \text{ mm}$	$R_2 \geq 100 \text{ mm}$

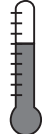

°C
(°F)

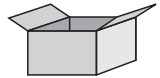

-20 ... 70 °C
(- 4 ... 158 °F)

IP 64
EN 60 529

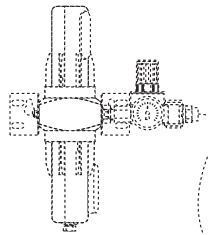



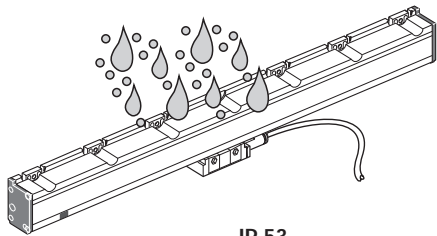

DA 300

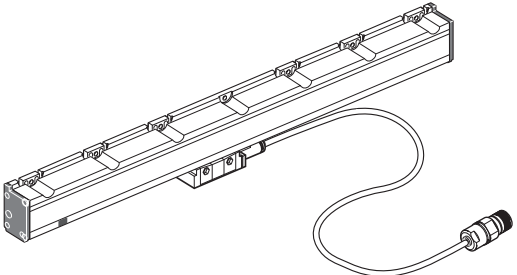





IP 53
EN 60 529

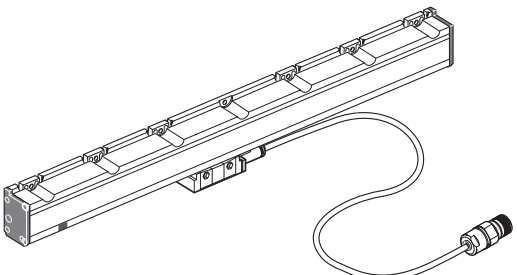

 RS-485
 Request Frame
 Request Frame
 $U_P = 5\text{ V} \pm 5\%$
 (max. 300 mA)
 EN 50 178/4.98; 5.2.9.5
 IEC 364-4-41: 1992; 411(PELV/SELV)
 (siehe, see, voir, vedi, véase
 HEIDENHAIN D 231 929)

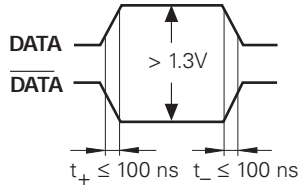

 DATA
 DATA
 RS-485

RS-485

Elektrischer Anschluss · *Electrical connection* · Raccordement électrique · *Collegamento elettrico* · Conexión eléctrica

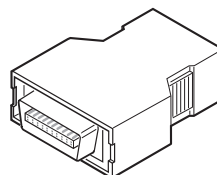
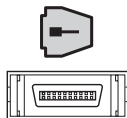
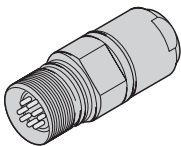
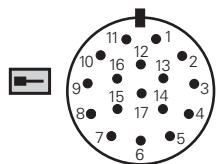

Außenschirm Gehäuse
External shield on housing
 Blindage externe sur le boîtier
Schermo esterno sulla carcassa
 Blindaje externo a carcasa

	14	17	8	9	7 ● — ● 1	10 ● — ● 4		
	6	16	7	17	20	19	1	11
	DATA	DATA	Request Frame	Request Frame	5 V Up	5 V sensor	0 V U_N	0 V sensor
	grau <i>gray</i> gris <i>grigio</i> gris	rosa <i>pink</i> rose <i>rosa</i> rosa	violett <i>violet</i> violet <i>viola</i> violeta	gelb <i>yellow</i> jaune <i>giallo</i> amarillo	braun/grün <i>brown/green</i> brun/vert <i>marrone/verde</i> marron/verde	blau <i>blue</i> bleu <i>azzurro</i> azul	weiß/grün <i>white/green</i> blanc/vert <i>bianco/verde</i> blanco/verde	weiß <i>white</i> blanc <i>bianco</i> blanco

Die Sensorleitung ist intern mit der Versorgungsleitung verbunden.
The sensor line is connected internally with the power supply.
 La ligne de palpeur est reliée de manière interne à la ligne d'alimentation.
La linea del sensore è collegata internamente con la linea di alimentazione.
 La línea de sensor está unida internamente con la línea de alimentación.

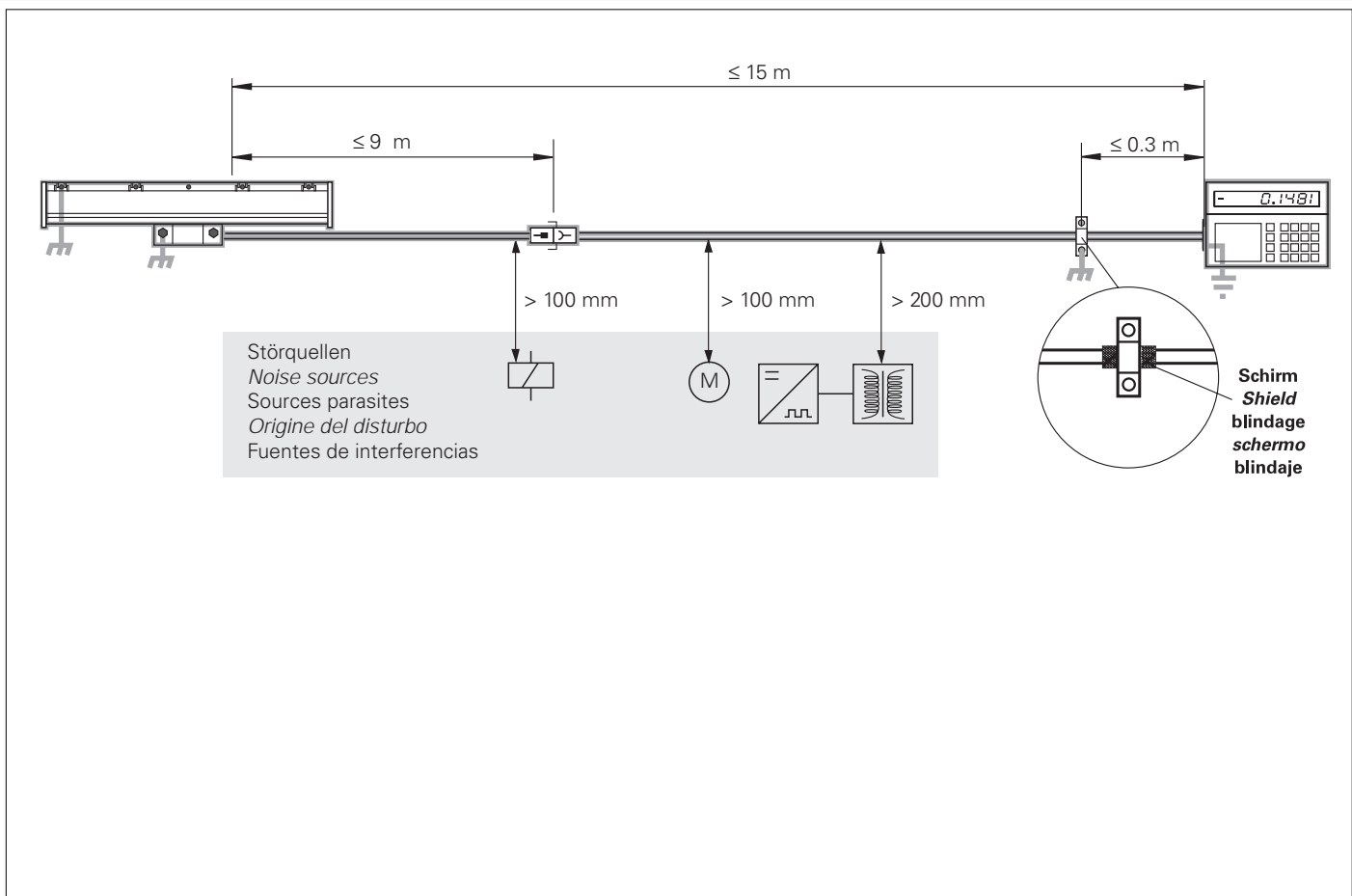

HEIDENHAIN

DR. JOHANNES HEIDENHAIN GmbH

Dr.-Johannes-Heidenhain-Straße 5

83301 Traunreut, Germany

☎ +49 (8669) 31-0

☎ +49 (8669) 5061

e-mail: info@heidenhain.de

Technical support ☎ +49 (8669) 31-1000

Measuring systems ☎ +49 (8669) 31-3104

e-mail: service.ms-support@heidenhain.de

TNC support ☎ +49 (8669) 31-3101

e-mail: service.nc-support@heidenhain.de

NC programming ☎ +49 (8669) 31-3103

e-mail: service.nc-pgm@heidenhain.de

PLC programming ☎ +49 (8669) 31-3102

e-mail: service.plc@heidenhain.de

Lathe controls ☎ +49 (7 11) 952803-0

e-mail: service.hsf@heidenhain.de

www.heidenhain.de

