

Montageanleitung
Mounting Instructions
Instructions de montage
Istruzioni di montaggio
Instrucciones de montaje

MT 2501

6/2002

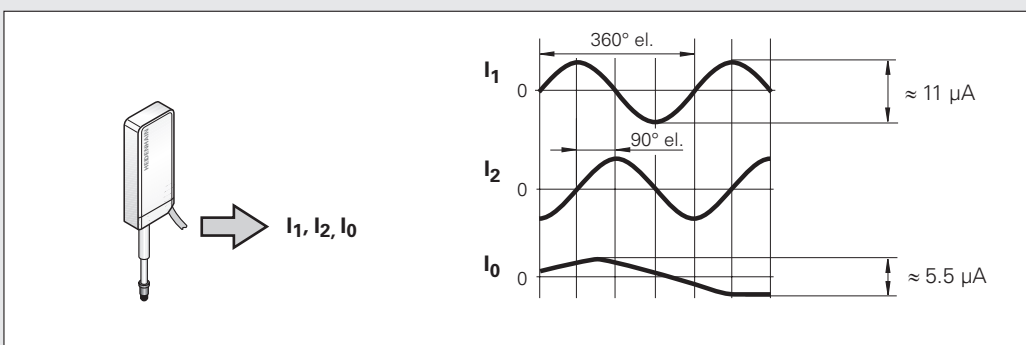
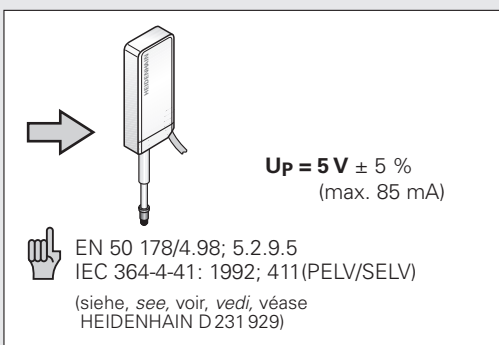

DR. JOHANNES HEIDENHAIN GmbH

Dr.-Johannes-Heidenhain-Straße 5

83301 Traunreut, Germany

☎ +49 (8669) 31-0

FAX +49 (8669) 50 61

E-Mail: info@heidenhain.de

Technical support ☎ +49 (8669) 32-10 00

Measuring systems ☎ +49 (8669) 31-31 04

E-Mail: service.ms-support@heidenhain.de

TNC support ☎ +49 (8669) 31-31 01

E-Mail: service.nc-support@heidenhain.de

NC programming ☎ +49 (8669) 31-31 03

E-Mail: service.nc-pgm@heidenhain.de

PLC programming ☎ +49 (8669) 31-31 02

E-Mail: service.plc@heidenhain.de

Lathe controls ☎ +49 (8669) 31-31 05

E-Mail: service.lathe-support@heidenhain.de

www.heidenhain.de



Ve 00

335 264-92 · 2.5 · 7/2007 · H · Printed in Germany · Änderungen vorbehalten

Subject to change without notice · Sous réserve de modifications · Con riserva di modifiche · Sujeto a modificaciones

MT 2501

mm
 Tolerancing ISO 8015
 ISO 2768 - m H
 < 6 mm: ±0.2 mm

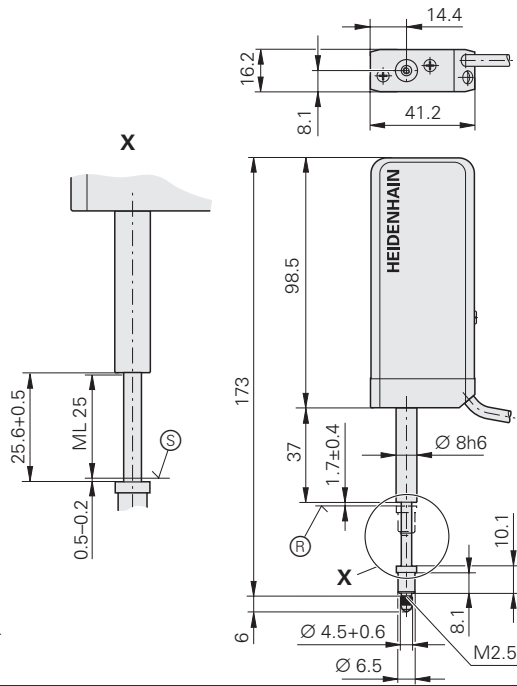

Ⓡ = Referenzmarken-Lage
Reference mark position
 Marque de référence
 Indici di riferimento
 Marca de referencia

Ⓢ = Beginn der Messlänge ML
Begin. of meas. length ML
 Début longueur utile ML
 Inizio lunghezza di misura ML
 Comienzo longitud útil ML

Ø 4.5 mm	$R_1 \geq 10 \text{ mm}$	$R_2 \geq 50 \text{ mm}$
	$R_1 \geq 40 \text{ mm}$	$R_2 \geq 100 \text{ mm}$

IP 50
 EN 60 529

°C
 (°F)

-20 ... 70 °C
 (-4 ... 158 °F)

Option
 Option
 Option
 Opzioni
 Opciones

ID 257 790-01

Zu starke Kraft klemmt Meßbolzen
Excessive force jams the plunger
 Force trop élevée serre la tige de mesure
 Una forza eccessiva blocca lo stelo di misura
 Una fuerza excesiva bloquea el vástago de medición

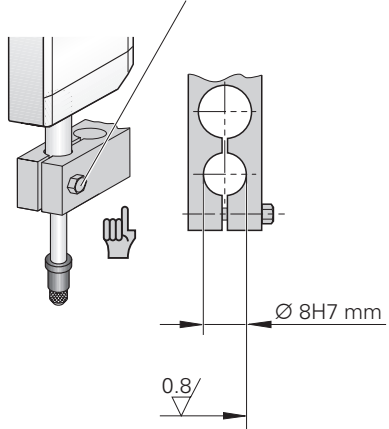

$F \leq 0.8 \text{ N}$
 $v = \text{max. } 30 \text{ m/min}$

$F = 0.6 \text{ N}$
 $F = 0.28 \text{ N}$
 $F = 0.44 \text{ N}$

Messeinsatz wechseln
Changing the measuring contact
 Changer de touche de mesure
 Cambiare dispositivo di misura
 Cambiar punta de medida

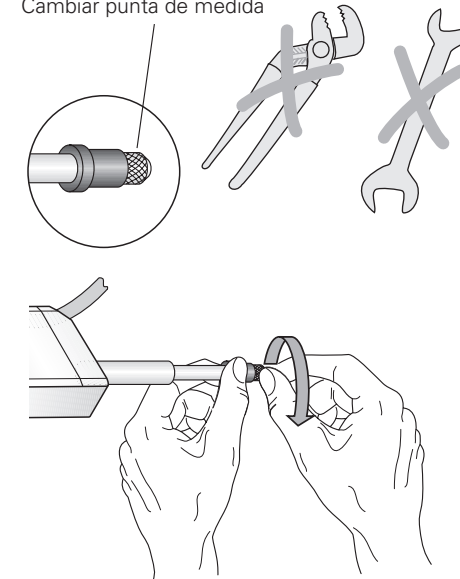

Ausfahrgeschwindigkeit einstellbar
Extension speed of plunger is adjustable
 Vitesse de sortie réglable
 Velocità di uscita regolabile
 Velocidad de salida ajustable

