

Montageanleitung  
*Mounting Instructions*  
Instructions de montage  
*Istruzioni di montaggio*  
Instrucciones de montaje

**ROD 1626.0001**  
**ROD 1626.0031**

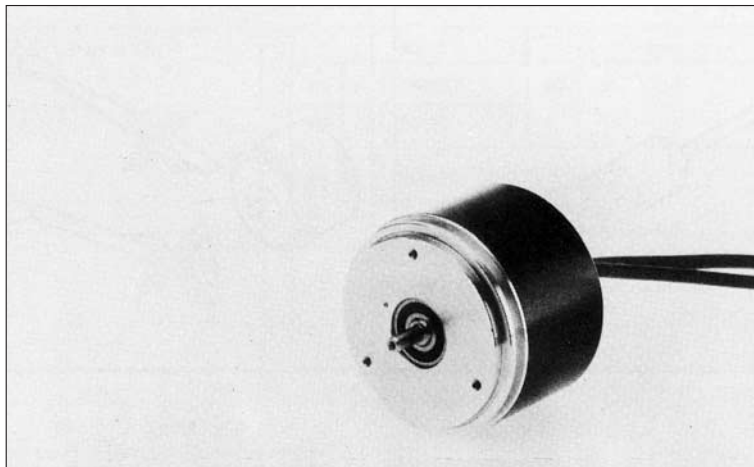



1.

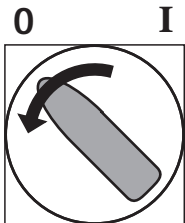

2.

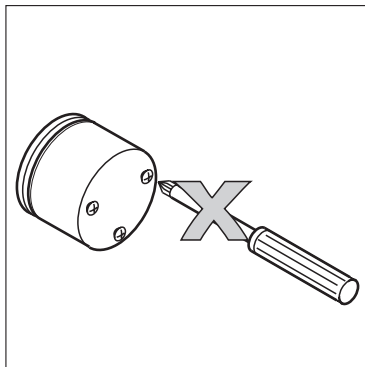
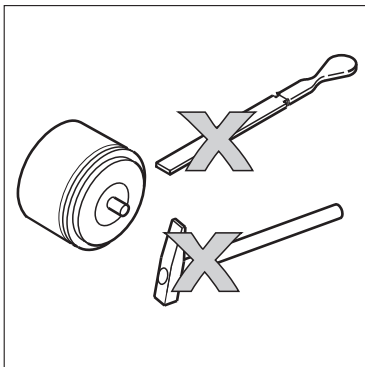
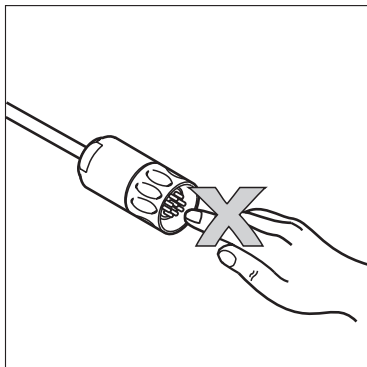
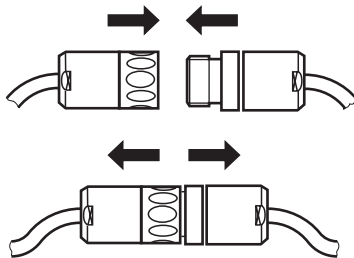

**ROD 1626.0001**  
**ROD 1626.0031**

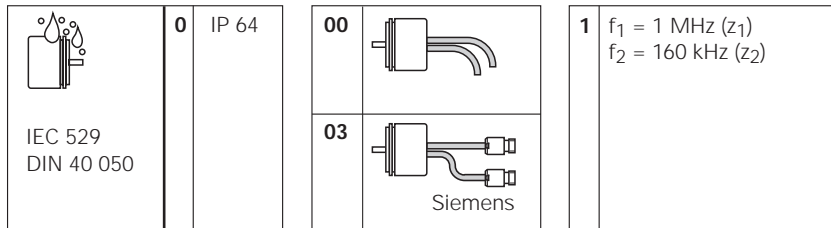

R O D 1 6 2 6 . 0 0 0 1 - 0 2 / 0 7

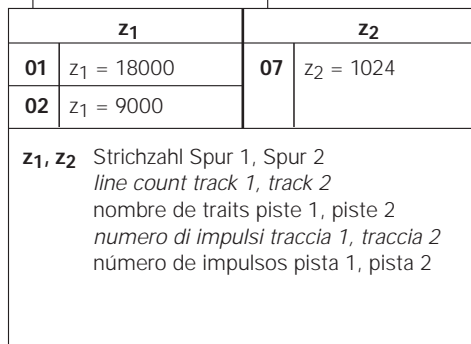
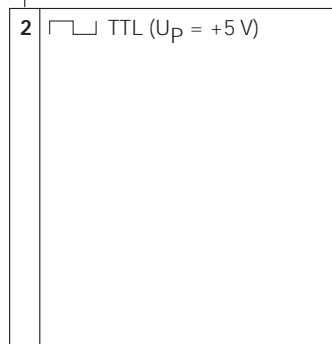

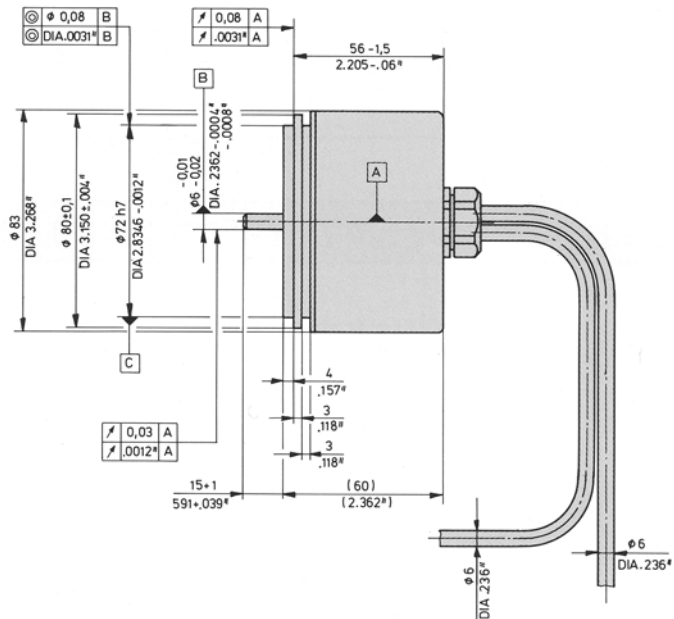

[A] Lagerung  
 ball bearing  
 roulement à billes  
 cuscinetto  
 rodamiento

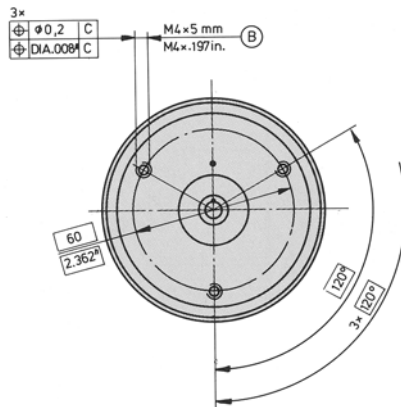

- (B) Befestigungsgewinde  
*threaded mounting hole*  
 trou de fixation taraudé  
*filettatura di fisaggio*  
 rosca de fijación

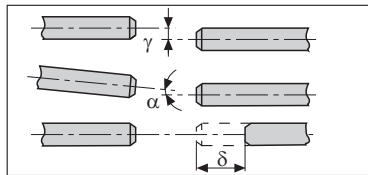

**K 17:**  $\gamma \leq 0.5 \text{ mm}$  (.02 in.)

**K 14:**  $\gamma \leq 0.2 \text{ mm}$  (.008 in.)

**K 17:**  $\alpha \leq 1^\circ$

**K 14:**  $\alpha \leq 0.5^\circ$

**K 17:**  $\delta \leq 0.5 \text{ mm}$  (.02 in.)

**K 14:**  $\delta \leq 0.2 \text{ mm}$  (.008 in.)

**K 17/01**

Id.-Nr. 226 521 01

**K 17/02**

Id.-Nr. 226 525 02



**K 14**



Id.-Nr. 200 365 01

Id.-Nr. 200 032 01

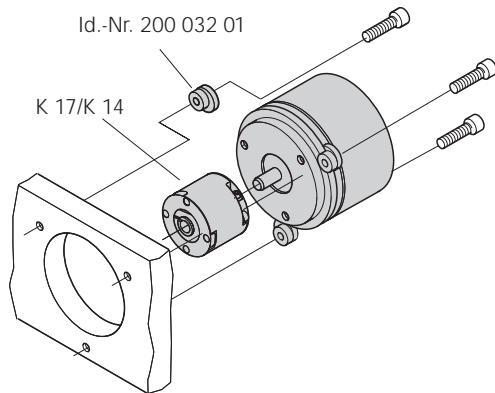
K 17/K 14

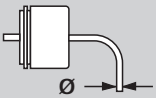
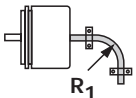
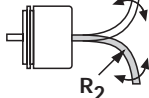

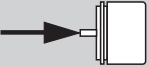
		
$\text{Ø } 6 \text{ mm}$ (.236 in.)	$R_1 \geq 20 \text{ mm}$ (.8 in.)	$R_2 \geq 75 \text{ mm}$ (3 in.)
$\text{Ø } 8 \text{ mm}$ (.315 in.)	$R_1 \geq 40 \text{ mm}$ (1.6 in.)	$R_2 \geq 100 \text{ mm}$ (4 in.)

	max. 20 N ( $z_1 \leq 9\,000$ ) max. 10 N ( $z_1 > 9\,000$ )
	max. 50 N ( $z_1 \leq 9\,000$ ) max. 10 N ( $z_1 > 9\,000$ )

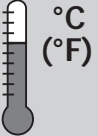
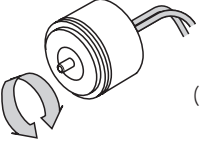
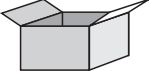
		0° ... 70° C (32° ... 158° F)
		-30° ... 80° C (-22° ... 176° F)

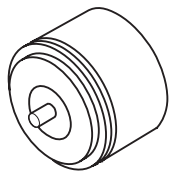

$$U_P = +5\text{ V} \pm 5\% \\ (\text{max. } 160\text{ mA})$$



$$U_P = +5\text{ V} \pm 5\% \\ (\text{max. } 160\text{ mA})$$



IEC 742  
DIN VDE 0100

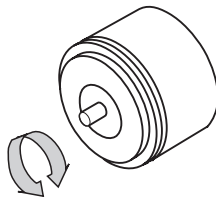

$$n = \begin{cases} \frac{1000}{z_1} \cdot 10^3 \cdot 60 \text{ min}^{-1} (z_1 = 9\,000; 18\,000) \\ \frac{160}{z_2} \cdot 10^3 \cdot 60 \text{ min}^{-1} (z_2 = 1\,024) \end{cases}$$

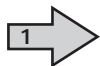
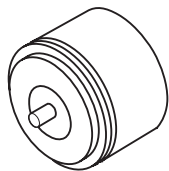

$$U_{a1}, U_{a2}, U_{a0} \\ \overline{U_{a1}}, \overline{U_{a2}}, \overline{U_{a0}}$$

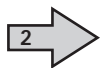

$$U_{a1}, U_{a2}, U_{a0} \\ \overline{U_{a1}}, \overline{U_{a2}}, \overline{U_{a0}}$$

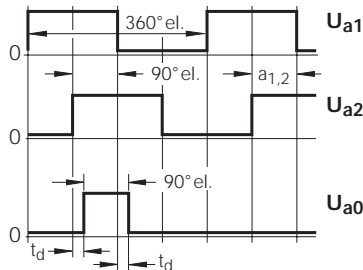

$$a_1 \geq 125\text{ ns} \\ (f_1 = 1\text{ MHz})$$

$$a_2 \geq 0.8\text{ }\mu\text{s} \\ (f_2 = 160\text{ kHz})$$

$$t_d \leq 50\text{ ns}$$



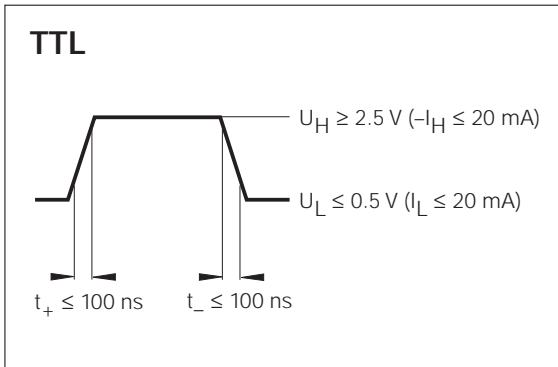
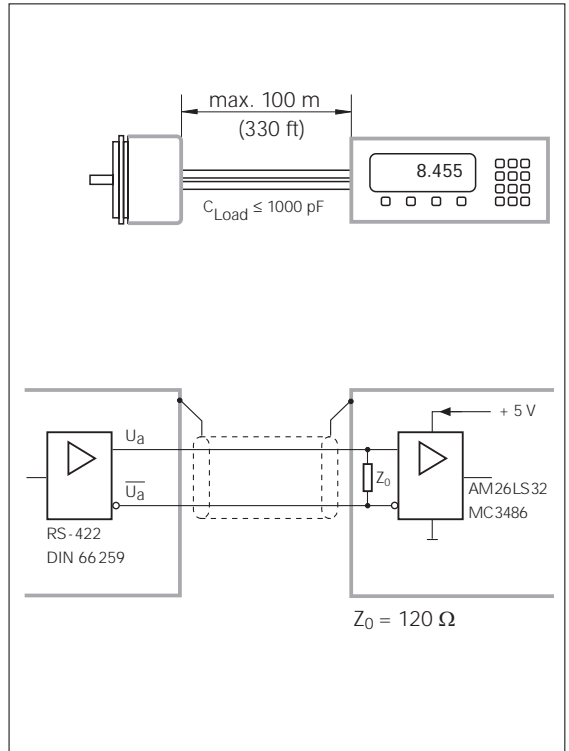
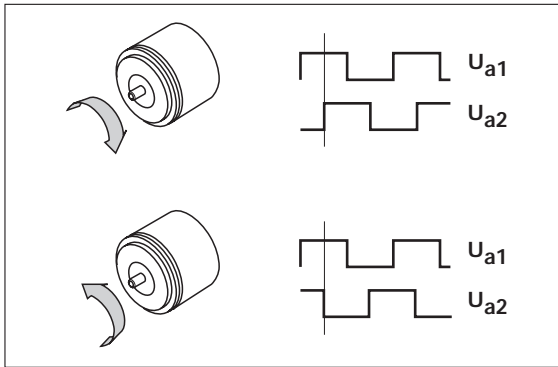

## ROD 1626.0001

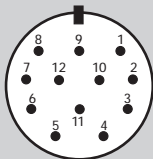
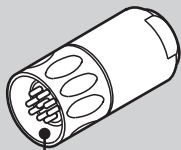

## ROD 1626.0031

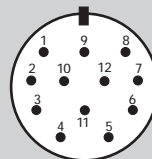
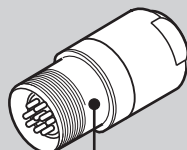

1	2	3	4	5	6	7	8	9			10	11	12
$\overline{U_{a2}}$	sensor 5 V	$U_{a0}$	$\overline{U_{a0}}$	$U_{a1}$	$\overline{U_{a1}}$	-	$U_{a2}$	-			0 V	sensor 0 V	+5 V
rosa pink rose rosa rosa	blau blue bleu azzurro azul	rot red rouge rosso rojo	schwarz black noir nero negro	braun brown brun marrone marrón	grün green vert verde verde	violett violet violet viola violeta	grau gray gris grigio gris	-		Schirm shield blindage schermo blindaje	weiß/grün white/green blanc/vert bianco/verde blanco/verde	weiß white blanc bianco blanco	braun/grün brown/green brun/vert marrone/verde marrón/verde

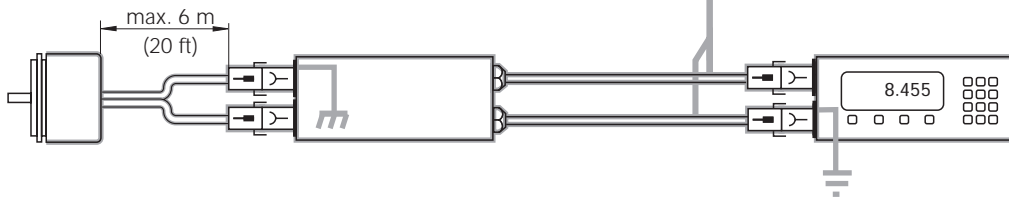



# HEIDENHAIN

---

**DR. JOHANNES HEIDENHAIN GmbH**

Dr.-Johannes-Heidenhain-Straße 5

**83301 Traunreut, Germany**

☎ +49 (86 69) 31-0

FAX +49 (86 69) 50 61

e-mail: [info@heidenhain.de](mailto:info@heidenhain.de)

---

**Technical support** FAX +49 (86 69) 31-10 00

**Measuring systems** ☎ +49 (86 69) 31-31 04

e-mail: [service.ms-support@heidenhain.de](mailto:service.ms-support@heidenhain.de)

**TNC support** ☎ +49 (86 69) 31-31 01

e-mail: [service.nc-support@heidenhain.de](mailto:service.nc-support@heidenhain.de)

**NC programming** ☎ +49 (86 69) 31-31 03

e-mail: [service.nc-pgm@heidenhain.de](mailto:service.nc-pgm@heidenhain.de)

**PLC programming** ☎ +49 (86 69) 31-31 02

e-mail: [service.plc@heidenhain.de](mailto:service.plc@heidenhain.de)

**Lathe controls** ☎ +49/7 11 95 28 03-0

e-mail: [service.hsf@heidenhain.de](mailto:service.hsf@heidenhain.de)

---

[www.heidenhain.de](http://www.heidenhain.de)



Chlorfrei gebleichtes Papier!  
*Paper bleached without chlorine!*  
Papier bianchi exempt de chlore!  
*Carta ecologica!*  
Papel blanqueado exento de cloro!