

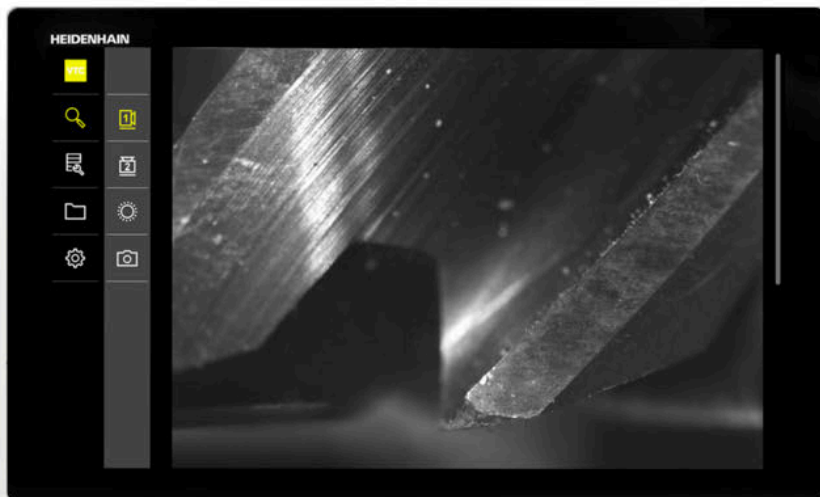

# HEIDENHAIN



## VTC

User's Manual

Software for VT 121, VT 122 Vision Systems

Version 1.4.x

English (en)  
11/2024

## Table of contents

<b>1</b>	<b>Fundamentals.....</b>	<b>7</b>
1.1	Overview.....	8
1.2	Information about the software.....	8
1.3	Documentation on the product.....	8
1.3.1	Validity of the documentation.....	8
1.3.2	Notes on reading the documentation.....	9
1.3.3	Storage and distribution of the documentation.....	9
1.4	About these instructions.....	10
1.4.1	Target groups for the instructions.....	10
1.4.2	Notes in this documentation.....	10
1.4.3	Symbols and fonts used for marking text.....	11
<b>2</b>	<b>Safety.....</b>	<b>13</b>
2.1	Overview.....	14
2.2	General safety precautions.....	14
2.3	Intended use.....	14
2.4	Improper use.....	14
2.5	Personnel qualification.....	14
2.6	Obligations of the operating company.....	15
2.7	General safety precautions.....	16
2.7.1	Electrical safety precautions.....	16
<b>3</b>	<b>Software Installation.....</b>	<b>17</b>
3.1	Overview.....	18
3.2	Installing the software.....	18
<b>4</b>	<b>Commissioning.....</b>	<b>19</b>
4.1	Overview.....	20
4.2	Configuring the vision system driver software.....	20
4.3	Selecting the vision system (camera).....	20

<b>5</b>	<b>VTC Cycles.....</b>	<b>21</b>
<b>5.1</b>	<b>Fundamentals.....</b>	<b>22</b>
5.1.1	VTC tool table.....	25
5.1.2	Overview.....	26
<b>5.2</b>	<b>Cycle 620 VT SETUP.....</b>	<b>28</b>
5.2.1	Cycle parameters.....	29
<b>5.3</b>	<b>Cycle 621 MANUAL INSPECTION.....</b>	<b>29</b>
5.3.1	Cycle parameters.....	31
<b>5.4</b>	<b>Cycle 622 IMAGES.....</b>	<b>32</b>
5.4.1	Cycle parameters.....	34
<b>5.5</b>	<b>Cycle 623 BREAKAGE CHECK.....</b>	<b>36</b>
5.5.1	Cycle parameters.....	37
5.5.2	Possible queries.....	38
<b>5.6</b>	<b>Cycle 624 MEASURING CUTTING EDGE ANGLES.....</b>	<b>39</b>
5.6.1	Cycle parameters.....	40
<b>5.7</b>	<b>Fundamentals of measuring cycles.....</b>	<b>41</b>
5.7.1	General information.....	41
<b>5.8</b>	<b>Cycle 625 VT CALIBRATION.....</b>	<b>42</b>
5.8.1	Cycle parameters.....	44
<b>5.9</b>	<b>Cycle 626 TEMPERATURE COMPENSATION.....</b>	<b>44</b>
5.9.1	Cycle parameters.....	46
<b>5.10</b>	<b>Cycle 627 TOOL LENGTH.....</b>	<b>47</b>
5.10.1	Cycle parameters.....	50
<b>5.11</b>	<b>Cycle 628 TOOL RADIUS.....</b>	<b>51</b>
5.11.1	Cycle parameters.....	53
<b>5.12</b>	<b>Cycle 629 TOOL RADIUS 2.....</b>	<b>55</b>
5.12.1	Cycle parameters.....	58
<b>5.13</b>	<b>Cycle 630 MEASURE TOOL.....</b>	<b>60</b>
5.13.1	Cycle parameters.....	62
<b>5.14</b>	<b>Cycle 631 MEASURE TOOL TIP.....</b>	<b>63</b>
5.14.1	Cycle parameters.....	65

<b>6</b>	<b>Basic operation.....</b>	<b>67</b>
6.1	Overview.....	68
6.2	User interface.....	68
6.3	Operation with touchscreen and gestures.....	69
6.4	General operating elements and functions.....	71
6.5	Manual tool inspection menu.....	73
6.6	Tool evaluation menu.....	74
6.7	Settings menu.....	75
<b>7</b>	<b>Manual Tool Inspection.....</b>	<b>77</b>
7.1	Overview.....	78
7.2	Displaying a camera image.....	79
7.3	Lighting palette.....	80
7.3.1	Opening the lighting palette.....	80
7.3.2	Operating elements of the Lighting palette.....	81
7.3.3	Configuring the lighting.....	82
7.4	Manual single shots.....	83
7.4.1	Taking a manual single shot.....	83
7.4.2	Parameters of the single shot.....	84
7.5	Cleaning.....	85

<b>8</b>	<b>Tool Evaluation.....</b>	<b>87</b>
<b>8.1</b>	<b>Overview.....</b>	<b>88</b>
<b>8.2</b>	<b>Navigating within the tool evaluation.....</b>	<b>89</b>
<b>8.3</b>	<b>Tool evaluation menu level.....</b>	<b>90</b>
8.3.1	Operating elements of the Tool evaluation menu level.....	90
8.3.2	Adding a new group.....	90
8.3.3	Renaming and customizing the group.....	91
8.3.4	Delete group.....	91
<b>8.4</b>	<b>Group menu level.....</b>	<b>92</b>
8.4.1	Operating elements of the Group menu level.....	93
8.4.2	Adding a new tool entry.....	93
8.4.3	Renaming and customizing the tool entry.....	94
8.4.4	Delete tool entry.....	94
<b>8.5</b>	<b>Tools menu level.....</b>	<b>95</b>
8.5.1	Operating elements of the Tools menu level.....	96
8.5.2	Adding a new image series.....	96
8.5.3	Renaming and customizing the image series.....	97
8.5.4	Deleting the image series and individual images.....	98
<b>8.6</b>	<b>Tool analysis.....</b>	<b>99</b>
8.6.1	Working in Image viewer mode.....	100
8.6.2	Working in Inspection mode.....	102
8.6.3	Working in Wear measurement mode.....	105
8.6.4	Transferring wear values via an export file.....	108
8.6.5	Working in Comparison mode.....	110

<b>9</b>	<b>Settings</b>	<b>113</b>
9.1	Overview	114
9.1.1	Software information	114
9.1.2	Image database	114
9.1.3	Sounds	114
9.1.4	Units	115
9.1.5	Copyrights	116
9.2	Sensors	116
9.2.1	Camera	116
9.2.2	Virtual camera or hardware camera	116
9.3	Interfaces	118
9.3.1	OPC UA-Server	118
9.4	Service	119
9.4.1	Firmware information	119
9.4.2	Back up and restore	120
9.4.3	Software options	120
9.4.4	Tools	120
<b>10</b>	<b>Service and Maintenance</b>	<b>121</b>
10.1	Overview	122
10.2	Back up settings	122
10.3	Restoring settings	123
10.4	Activating Software options	123
10.5	Requesting license key	124
10.6	Activating a license key	125
10.6.1	Uploading license key from license file	125
10.6.2	Entering license key manually	125
10.7	Checking the Software options	126
<b>11</b>	<b>Index</b>	<b>127</b>
<b>12</b>	<b>List of figures</b>	<b>128</b>

# 1

## Fundamentals

## 1.1 Overview

This chapter contains information about the product and this manual.

## 1.2 Information about the software

The VTC software is part of a vision system for tool inspection. In combination with the VT 121 vision system, the software enables the user to check the tool condition and wear while the tool is inside the machine's work envelope. The VT 122 vision system also enables tool measurement.

In addition to this, the following applications are possible:

- Tool inspection before critical machining steps
- Optimization of cutting parameters
- Optimization of NC programs
- Breakage control
- Tool inspection after expiration of tool life

The VTC software can be connected to a HEIDENHAIN-TNC7 or TNC 640 control with NC software 34059x-10 and later. Imaging, inspection for breakage and measurement are controlled through cycles in an automated process.

The VTC software allows the user to evaluate images visually. Further functions include: manual taking of images, control of lighting and exposure time, as well as image database management.

## 1.3 Documentation on the product

### 1.3.1 Validity of the documentation

Before using the documentation and the software, you need to verify that the documentation matches the software.

This User's Manual is valid for version 1280600.1.4.x of the VTC software as well as for the cycle packages 1386761-xx-xx (TNC7) and 1334619-xx-03-xx (TNC 640) for the VT 121 and VT 122 vision systems.



If the version numbers do not match so that the documentation is not valid, you will find the current documentation at [www.heidenhain.com](http://www.heidenhain.com).

### 1.3.2 Notes on reading the documentation

<b>⚠ WARNING</b>	
<b>Fatal accidents, personal injury or property damage caused by non-compliance with the documentation!</b>	
Failure to comply with the documentation may result in fatal accidents, personal injury or property damage.	
<ul style="list-style-type: none"> <li>▶ Read the documentation carefully from beginning to end</li> <li>▶ Keep the documentation for future reference</li> </ul>	

The following table lists the various parts of the documentation in their order of reading priority.

Document type	Description
Addendum	An Addendum supplements or supersedes the corresponding contents of the Operating Instructions and the User's Manual. If an Addendum is included in the shipment, it has the highest reading priority. All other documentation content retains its validity.
Operating Instructions	The Operating Instructions contain all the information and safety precautions needed for the proper mounting and installation of the product. The Operating Instructions are included in delivery. The Operating Instructions have the second highest priority for reading.
User's Manual	The User's Manual contains all the information and safety precautions needed for the proper operation of the product according to its intended use. The User's Manual can be downloaded from the download area at <b>www.heidenhain.com</b> . The User's Manual has the third highest reading priority.

**Have you found any errors or would you like to suggest changes?**

We are continuously striving to improve our documentation for you. Please help us by sending your suggestions to the following e-mail address:

**userdoc@heidenhain.de**

### 1.3.3 Storage and distribution of the documentation

The User's Manual must be kept in the immediate vicinity of the workplace and must be available to all personnel at all times. The operating company must inform the personnel where the User's Manual is kept. If the User's Manual has become illegible, the operating company must obtain a new copy from the manufacturer.

If the software is passed on to any other party, the User's Manual must also be passed on to the new owner.

## 1.4 About these instructions

These instructions provide all the information and safety precautions needed for the proper operation of the VTC software.

### 1.4.1 Target groups for the instructions

These instructions must be read and observed by every person who performs any of the following tasks:

- Software installation
- Software configuration
- Operation
- Service and maintenance

### 1.4.2 Notes in this documentation

#### Safety precautions

Precautionary statements warn of hazards in handling the product and provide information on their prevention. Precautionary statements are classified by hazard severity and divided into the following groups:

#### DANGER

**Danger** indicates hazards for persons. If you do not follow the avoidance instructions, the hazard **will result in death or severe injury**.

#### WARNING

**Warning** indicates hazards for persons. If you do not follow the avoidance instructions, the hazard **could result in death or serious injury**.

#### CAUTION

**Caution** indicates hazards for persons. If you do not follow the avoidance instructions, the hazard **could result in minor or moderate injury**.

#### NOTICE

**Notice** indicates danger to material or data. If you do not follow the avoidance instructions, the hazard **could result in property damage**.

#### Informational notes

Informational notes ensure reliable and efficient operation of the product. Informational notes are divided into the following groups:



The information symbol indicates a **tip**.

A tip provides important additional or supplementary information.



The gear symbol indicates a function that **depends on the machine**.

The function described depends on the machine if, for example:

- Your machine features a certain software or hardware option
- The behavior of the functions depends on the configurable machine settings



The book symbol indicates a **cross reference**.

A cross reference leads to external documentation, for example the documentation of your machine manufacturer or other supplier.

### 1.4.3 Symbols and fonts used for marking text

Format	Meaning
▶ ... > ...	Identifies an action and the result of this action Example: ▶ Tap <b>OK</b> > The message is closed
■ ... ■ ...	Identifies an item of a list Example: ■ TTL interface ■ EnDat interface ■ ...
<b>Bold</b>	Identifies menus, displays and buttons Example: ▶ Tap <b>Shut down</b> > The operating system shuts down ▶ Turn the power switch off



# 2

**Safety**

## 2.1 Overview

This chapter provides important safety information needed for the proper mounting and installation of the product.

## 2.2 General safety precautions

Generally accepted safety precautions, in particular the applicable precautions relating to the handling of live electrical equipment, must be followed when operating the system. Failure to observe these precautions could result in damage to the device, or injury to personnel.

It is understood that safety rules within individual companies vary. If a conflict exists between the material contained in these instructions and the rules of a company using this system, the more stringent rules take precedence.

## 2.3 Intended use

The VTC software is intended solely for the following use:

- Inspection and visual measurement of tools in machining centers
- In-process measurement of tools in machining centers (only in combination with the VT 122 vision system)

## 2.4 Improper use

Any use not specified in 'Intended use' is considered improper use. The machine manufacturer and the company operating the machine are solely liable for any damage resulting from improper use.

Especially its use as part of a safety function is not permitted.

## 2.5 Personnel qualification

The personnel for operating the product must be appropriately qualified for this work and must have obtained sufficient information from the documentation supplied with the product and with the connected peripherals.

The personnel required for the individual activities to be performed on the product are indicated in the respective sections of these instructions.

The personnel groups are specified in detail as follows with regard to their qualifications and tasks.

### Operator

The operator uses and operates the product within the framework specified for the intended use. He is informed by the operating company about the special tasks and the potential hazards resulting from incorrect behavior.

### Qualified personnel

The qualified personnel are trained by the operating company to perform advanced operation and parameterization. The qualified personnel have the required technical training, knowledge and experience and know the applicable regulations, and are thus capable of performing the assigned work regarding the application concerned and of proactively identifying and avoiding potential risks.

## 2.6 Obligations of the operating company

The operating company owns or leases the device and the peripherals. At all times, the operating company is responsible for ensuring that the intended use is complied with.

The operating company must:

- Assign the different tasks to be performed on the device to suitable, qualified and authorized personnel
- Verifiably train the personnel in the authorizations and tasks
- Provide all materials and means necessary in order for the personnel to complete the assigned tasks
- Ensure that the device is operated only when in perfect technical condition
- Ensure that the device is protected from unauthorized use

## 2.7 General safety precautions

**i** The safety of any system incorporating the use of this product is the responsibility of the assembler or installer of the system.

The specific safety precautions required for the individual activities to be performed on the product are indicated in the respective sections of these instructions.

### 2.7.1 Electrical safety precautions

#### **⚠ WARNING**

##### **Hazard of contact with live parts when opening the product!**

This may result in electric shock, burns or death.

- ▶ Never open the housing
- ▶ Only the manufacturer is permitted to access the inside of the product

#### **⚠ WARNING**

##### **Hazard of dangerous amount of electricity passing through the human body upon direct or indirect contact with live electrical parts!**

This may result in electric shock, burns or death.

- ▶ Work on the electrical system and live electrical components is to be performed only by trained specialists
- ▶ For power connection and all interface connections, use only cables and connectors that comply with applicable standards
- ▶ Have the manufacturer exchange defective electrical components immediately
- ▶ Regularly inspect all connected cables and all connections on the product. Defects, such as loose connections or scorched cables, must be removed immediately

#### **NOTICE**

##### **Damage to internal parts of the product!**

If you open the product, the warranty and the guarantee will become void.

- ▶ Never open the housing
- ▶ Only the product manufacturer is permitted to access the inside of the product

# 3

**Software  
Installation**

## 3.1 Overview

This chapter provides all of the information needed for downloading and properly installing VTC on a computer.

## 3.2 Installing the software

### Downloading the installer

To install VTC, you need to download the installer from the HEIDENHAIN website [www.heidenhain.com](http://www.heidenhain.com)

- ▶ Download the current version from:  
[www.heidenhain.com/service/downloads/software/](http://www.heidenhain.com/service/downloads/software/)



Change the selected category, if necessary.

- ▶ Navigate to the Download folder of your web browser
- ▶ Unzip the downloaded files into a temporary folder
- > The installer files will be unpacked into the temporary folder.

### Verifying the requirements

To ensure proper operation of VTC, HEIDENHAIN recommends a PC that meets the following minimum requirements:

- Quad-core processor
- Main memory: 8 GB RAM
- Hard disk space of 0.5 GB for approx. 1000 images
- Microsoft Windows 11 or Microsoft Windows 10

### Installing VTC and the driver software



In order to perform the installation, you need to log in to Microsoft Windows as an administrator.

To install VTC and the driver software:

- ▶ Double-click each installer file to start it
- > The Setup Wizard opens.
- ▶ Accept the license conditions
- ▶ Follow the setup wizard instructions
- > VTC and the driver software are installed; if selected, a desktop icon is created.
- ▶ Click the **Finish** button to complete the installation process
- > VTC and the driver software have been installed successfully.

# 4

## Commissioning

## 4.1 Overview

This chapter contains all the information necessary for putting the product into operation. This requires the connection between the VT 121 or VT 122 vision system and the VTC software to be configured.

## 4.2 Configuring the vision system driver software

In order for VTC to detect the vision system, you have to configure it using the IDS Camera Manager driver software.

To configure the connected vision system:

- ▶ Start the **IDS Camera Manager** driver software via the Microsoft Windows Start Menu.
- > An entry for the vision system is shown in the **Camera list** table.
- ▶ Tap the **Automatic ETH configuration** button
- > The configuration is automatically run and confirmed by means of a dialog box.
- > In the **Free** and **Avail.** columns of the **Camera list** table, the entry **Yes** is shown. If automatic configuration fails:
  - ▶ Tap **Expert mode**
  - ▶ The **IDS Camera Manager** dialog is expanded
  - ▶ Tap the **Manual ETH configuration** button
  - ▶ Enter the static IP address of the vision system in the **Parameters** area



Have an IT specialist enter the IP address.

- ▶ Tap the **Close** button

## 4.3 Selecting the vision system (camera)

In order for VTC to control the vision system, you must select it in the settings.



- ▶ Tap **Settings** in the main menu



- ▶ Tap **Sensors**
- ▶ Tap **Camera**
- ▶ Select the desired camera
- ▶ Click **Activate**
- > The selected camera is available in VTC.

# 5

**VTC Cycles**

## 5.1 Fundamentals



Refer to your machine manual.

This feature must be enabled and adapted by the machine tool builder.

The **Python** software option (#46/#7-01-1) must have been enabled.

The **Remote Desktop Manager** software option (#133/#3-01-1) must have been enabled.



HEIDENHAIN only guarantees the proper operation of the VTC cycles if the vision system is set up with a HEIDENHAIN touch probe.

In order to use the camera-based tool inspection, you need the following components:

- VTC software
- Camera driver
- **Python** (#46/#7-01-1)
- **Remote Desktop Manager** (#133/#3-01-1)
- Hardware:
  - HEIDENHAIN VT 121 or VT 122 vision system and accessories
  - External computer unit with Microsoft Windows 10 or 11 operating system
  - Touch probe

### Application

The camera-based tool inspection allows you to inspect your tool visually on an external computer unit on the basis of images, thus checking it for wear. It also helps you to detect tool breakage before and during the machining process. Additionally, you can measure the tool and determine the length, radius, corner radius, and point angle tool data. The cycles become available on the control immediately after setup of the VTC software. The VTC software is run on an external computer unit with Microsoft Windows 10 operating system.

Visual tool inspection can be performed on cylindrical, ball-nose and toroid cutters. Camera 2 also allows you to visually inspect drills.

The control uses the following tool management entries to identify the different tool types.

Tool type	R	R2	T-ANGLE
Cylindrical cutter	> 0	0	0
Ball-nose cutter	> 0	= R	0
Toroid cutter	> 0	> 0 and < R	0
Drill	> 0	0	> 0

### Terms

The following terms are used in connection with VTC:

Term	Explanation
Camera 1	Usually shows the tool from the side.
Camera 2	Usually shows the tool from below.
Single shot	A single shot is an image of an individual cutting edge.
Panoramic image	A panoramic image is a 360° view of the tool, possibly with inspection mode.
Mosaic image	A mosaic image is a complete image of the tool from below.
Profile image	A profile image is an image of individual cutting edges of ball-nose or toroid cutters with indexable inserts.
Tool evaluation	The images that were taken are stored in the tool evaluation.
Clearance height	The clearance height is specified in the cycle. The clearance height is 20.5 mm and is based on the reference surface of camera 2.
Focal plane / Setup clearance	The focal plane is at the center of the camera. The safety clearance to the camera is as follows and is based on the reference surface of camera 1. <ul style="list-style-type: none"> <li>■ VT 121 = 20.5 mm</li> <li>■ VT 122 = 52 mm</li> </ul>

### Things to keep in mind regarding VTC cycles

All VTC cycles are DEF-active. The control runs the cycle automatically as soon as it reads the cycle definition in the program run.



Your machine tool builder defines the feed rates, positioning and spindle speed.

### NOTICE

#### Danger of collision!

Danger of collision if the tool is positioned automatically in front of the camera. The camera, the machine and the tool may be damaged.

- ▶ Refer to your machine manual.
- ▶ Use **M140 MB MAX** to move to maximum height prior to positioning

### NOTICE

#### Danger of collision!

For visual inspection at camera 1, the cycle moves the tool to the outer tool radius. If the radius of the tool shaft is larger than the tool radius, there is a danger of collision.

- ▶ Test the NC program or program section in **Program run, single block** operating mode

### NOTICE

#### Danger of collision!

If you switched on the spindle before calling the cycle, the control will **not** reconstruct this previous state at the end of the cycle if there is a cycle **interruption**. There is a danger of collision!

- ▶ Check the spindle speed after the end of the cycle
- ▶ If required, call the tool again with the desired speed after the cycle call
- ▶ Program a spindle start after an interruption of the NC program

### NOTICE

#### Danger of collision!

If the tool has not been measured based on its bottom edge during the visual inspection, then there is a danger of collision!

- ▶ Measure the tool based on its bottom edge
- ▶ Prior to this, measure the tool length with the measuring cycles **627** or **630**

### NOTICE

#### Danger of collision!

If the actual tool diameter is greater than the measured tool diameter, then there is a danger of collision with camera 1!

- ▶ Measure the tool based on its outermost radius

- HEIDENHAIN recommends executing the cycle in **FUNCTION MODE MILL** machining mode.
- To attain useful results, the light must be adjusted optimally. Cycle **621 MANUAL INSPECTION** allows you to adjust the light.
- The images must be taken in the same position of the rotary axes and with the same kinematic configuration that was used for the calibration of the camera. Your machine manufacturer can save this position setting in the cycles, if required.

### 5.1.1 VTC tool table

Use the **VTC-TOOLS.TAB** to save the data that you need to take single shots. The table can be found in the **TNC:\table\** folder.

Abbr.	Inputs	Dialog
<b>T</b>	Tool number Tool number from the <b>TOOL.T</b>	-
<b>START-ANGLE</b>	Spindle angle of the cutting edge You can use Cycle <b>624</b> to determine or manually enter the spindle angles of the cutting edges. The minimum tool diameter is 1.9 mm for automatic cutting edge measurement.	Spindle angle of the first cutting edge
<b>TOOL-ID</b>	Tool ID number The tool ID number enables the operator to identify the tool in the tool evaluation. The ID number consists of the current date and a timestamp accurate to the second (e.g. <b>20191014112159</b> ).	TOOL-ID
<b>ANGLE-2</b> to <b>ANGLE-32</b>	Spindle angle of cutting edges 2 to 32 You can use Cycle <b>624</b> to determine or manually enter the spindle angles of the cutting edges.	Spindle angle of the second cutting edge ....
<b>REF-ANGLE</b>	Contact angle in degrees Using the contact angle, you define the point on the tool radius <b>R</b> or <b>R2</b> to which the camera will focus on the tool. This value is effective for ball-nose and toroid cutters only.	Contact angle



Operating notes:

- If the cutting edges are spaced evenly along the circumference of the milling tool, one angle and the number of cutting edges **CUT** in the tool table are sufficient.
- You can ascertain the spindle angle of the cutting edge with Cycle **624** or by means of a tool presetter and enter it manually.
- The tool is saved until you delete it manually or overwrite it with a tool with identical tool number **T**.

### 5.1.2 Overview

The control provides cycles that enable you to program camera-based tool monitoring.

Proceed as follows:

- ▶ Select the **TOUCH PROBE** soft key
- ▶ The control shows the available cycle groups.
- ▶ Select **VTC**

The control provides the following cycles:

**i** Cycles **620** to **624** are available with the **VT 121** and **VT 122** vision systems.  
Cycles **625** to **631** are available only with the **VT 122** vision system.

Cycle-number	Cycle	Page
<b>620</b>	VT SETUP <ul style="list-style-type: none"> <li>■ Calibration of the vision system</li> </ul>	28
<b>621</b>	MANUAL INSPECTION <ul style="list-style-type: none"> <li>■ Tool check with live image</li> <li>■ Adjustment of lighting</li> <li>■ Selection of camera 1 or camera 2</li> </ul>	29
<b>622</b>	IMAGES <ul style="list-style-type: none"> <li>■ Automatic capture and storage of images</li> <li>■ Selection of image capture mode</li> <li>■ Selection of camera 1 and/or camera 2</li> </ul>	32
<b>623</b>	BREAKAGE CHECK <ul style="list-style-type: none"> <li>■ Simple breakage detection</li> <li>■ Selection of camera 1</li> </ul>	36
<b>624</b>	MEASUREMENT OF CUTTING EDGE ANGLE <ul style="list-style-type: none"> <li>■ Automatic measurement of the spindle angle of all cutting edges</li> <li>■ Selection of camera 2</li> </ul>	39
<b>625</b>	VT CALIBRATION <ul style="list-style-type: none"> <li>■ Calibration of the VT 122 vision system with a reference tool</li> </ul>	42
<b>626</b>	TEMPERATURE COMPENSATION <ul style="list-style-type: none"> <li>■ Compensation of temperature-related deviations</li> <li>■ Performing a reference measurement or comparative measurement</li> </ul>	44
<b>627</b>	TOOL LENGTH <ul style="list-style-type: none"> <li>■ Measuring the tool length</li> <li>■ Writing of tool length or delta length to the tool table</li> </ul>	47
<b>628</b>	TOOL RADIUS <ul style="list-style-type: none"> <li>■ Measuring the tool radius</li> <li>■ Writing of tool radius or delta radius to the tool table</li> </ul>	51

<b>Cycle-number</b>	<b>Cycle</b>	<b>Page</b>
<b>629</b>	TOOL RADIUS 2 <ul style="list-style-type: none"><li>■ Measuring corner radius <b>R2</b></li><li>■ Adapting the length and the radius using the result of the corner radius.</li><li>■ Writing of the tool length, tool radius and <b>R2</b> or delta values to the tool table</li></ul>	55
<b>630</b>	MEASURE TOOL <ul style="list-style-type: none"><li>■ Measuring the tool length and radius</li><li>■ Writing of tool length and radius or delta values to the tool table</li></ul>	60
<b>631</b>	MEASURE TOOL TIP <ul style="list-style-type: none"><li>■ Measuring the theoretical tool length, length of the cylindrical part of the drill or the point angle</li><li>■ Writing of tool length or delta length <b>DL</b> to the tool table</li><li>■ Writing of point angle to the tool table</li></ul>	63

## 5.2 Cycle 620 VT SETUP

### Application

**i** HEIDENHAIN only guarantees the proper operation of the **VT SETUP** cycle in conjunction with HEIDENHAIN touch probes.

Cycle **620 VT SETUP** calibrates the vision system with a touch probe. The cycle uses the circular top surface of the camera as starting position. You have to pre-position your touch probe manually above the starting position.

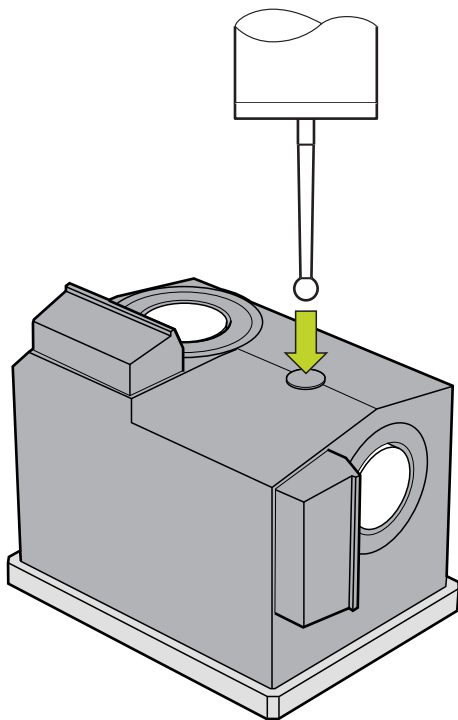

The coordinates of the vision system determined during calibration are coordinates in the machine coordinate system.

#### Cycle sequence:

- 1 This cycle interrupts the NC program.
- 2 The control displays a dialog window indicating that the touch probe must be placed at the right position.
- 3 Manual intervention:
  - ▶ Position the touch probe above the circular surface
  - ▶ Press **NC Start** as soon as the touch probe has reached the right position
- 4 Then the control probes the circular surface in the tool axis.
- 5 The touch probe moves to the adjacent sides of the corner point **Q624** and probes the two sides.
- 6 At the end of the cycle, the touch probe returns to the clearance height.

### Notes

- VTC cannot be run actively in combination with **Tilt working plane**.
- **Further information:** "Things to keep in mind regarding VTC cycles", Page 24

## 5.2.1 Cycle parameters

### Help graphic

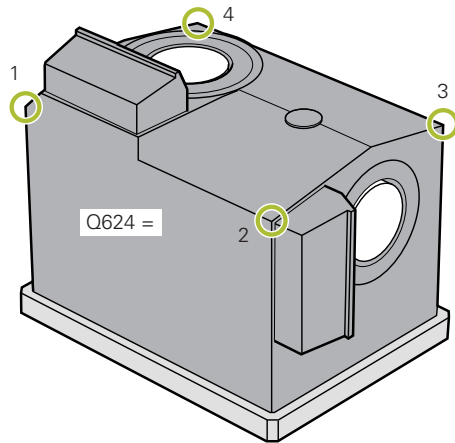

### Parameter

#### Q623 Viewing angle of side camera X+

Approximate angle ( $\pm 10^\circ$ ) of the viewing direction of camera 1 from the principal axis X+. The control determines the exact angle during calibration.

Input: **0...360**

#### Q624 Number of corner for preset

The number of the corner defines the adjacent sides to be probed.

Input: **1, 2, 3, 4**

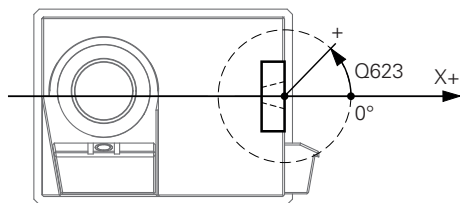

### Example

11 TCH PROBE 620 VT EINRICHTUNG ~	
Q623=+0	;VIEWING ANGLE ~
Q624=+1	;NUMBER OF CORNER

## 5.3 Cycle 621 MANUAL INSPECTION

### Application

Cycle **621 MANUAL INSPECTION** allows you to check tools visually and adjust the lighting.

#### Cycle sequence:

- 1 The control moves the tool to the clearance height and then positions it in front of the selected camera.
  - **Q620=1**: The control positions the tool next to camera 1, shifted by the tool radius and the safety clearance. Positioning depends on **Q629 Contact angle**.
  - **Q620 = 2**: The control positions the tool to the clearance height above the camera 2.
- 2 Then the cycle deactivates any spindle revolution that may be active.
- 3 You can resume the cycle with **NC Start**.
- 4 At the end of the cycle, the control positions the tool to the clearance height.
- 5 If the spindle revolution was active before the cycle call, the control restores this condition at the end of the cycle.

**Further information:** "Things to keep in mind regarding VTC cycles", Page 24

**Cleaning function**

- Before the start of the cycle, the compressed-air jets on the two cameras are activated for two seconds.
- Before the **MANUAL INSPECTION** cycle, compressed air is applied to the tool for one second.

**Notes****Tool notes****Image from the side – camera 1**

<b>Tool type</b>	<b>Minimum tool diameter</b>	<b>Maximum tool diameter</b>	<b>R2</b>
Drill	0.2 mm	32 mm	-
End mill	0.2 mm	No limitation	-
Ball-nose cutter	0.2 mm	32 mm	-
Toroid cutter	0.2 mm	32 mm	<=16 mm

**Image from below – camera 2**

<b>Tool type</b>	<b>Minimum tool diameter</b>	<b>Maximum tool diameter</b>	<b>R2</b>
Drill	0.2 mm	32 mm	-
End mill	0.2 mm	No limitation	-
Ball-nose cutter	0.2 mm	32 mm	-
Toroid cutter	0.2 mm	32 mm	<=16 mm

- Depending on the tool, you have to save the following values in the tool table:
  - **R**
  - **L**
- **Further information:** "Things to keep in mind regarding VTC cycles", Page 24

### 5.3.1 Cycle parameters

#### Help graphic

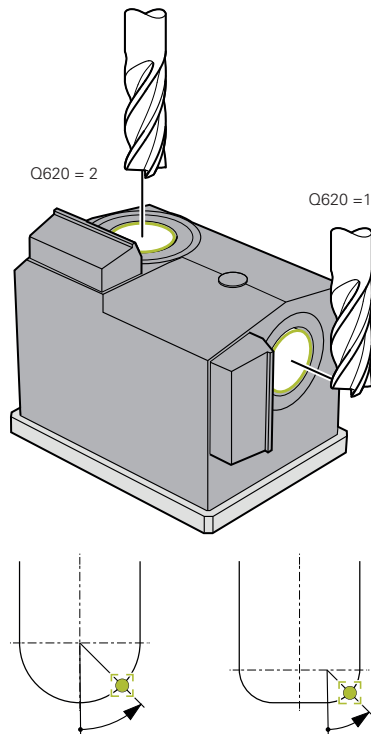

#### Parameter

##### Q620 Selection of the camera(s)

Select the camera 1 or camera 2:

**1:** Camera 1 – live image of the tool from the side

**2:** Camera 2 – live image of the tool from below

Input: **1, 2**

##### Q629 Contact angle at R/R2

Using the contact angle, you define the point on the corner radius to which the camera will focus on the tool.

**>=1:** The control uses the defined contact angle to focus on the individual cutting edges.

**0:** No contact point; the control focuses on the lower cutting edge of the tool.

**-1:** REF-ANGLE value from the VTC tool table

This parameter is effective for ball-nose and toroid cutters only.

Input: **-1...90**

#### Example

```
11 TCH PROBE 621 MANUAL INSPECTION ~
```

```
Q620=+1 ;CAMERA SELECTION ~
```

```
Q629=+0 ;CONTACT ANGLE
```

## 5.4 Cycle 622 IMAGES

### Application

Cycle **622 IMAGES** allows you to take and store images of the tool.

#### Cycle sequence:

- 1 The control moves the tool to the clearance height and then positions it in front of the selected camera:
  - **Q620 = 1**: The control positions the tool next to camera 1, shifted by the tool radius and the safety clearance.
  - **Q620 = 2**: The control positions the tool to the clearance height above the camera 2.
- 2 The spindle revolution is stopped or reduced depending on **Q621**:
  - Panoramic image at camera 1: Spindle revolution is reduced
  - Panoramic image at camera 2: Spindle revolution is stopped
  - Single shot: Spindle revolution is stopped
- 3 The cycle generates the desired images
  - If **Q622** is not equal to 0, the control takes multiple images on several focal planes, depending on radius **R2**.
- 4 The external computer unit saves the images in the tool evaluation of the VTC software in the subfolder defined.
- 5 At the end of the cycle, the control positions the tool to the clearance height.
- 6 If the spindle revolution was active before the cycle call, the control restores this condition at the end of the cycle.

#### Cleaning function

- Before the start of the cycle, the compressed-air jets on the two cameras are activated for two seconds.
- Before an image is taken, compressed air is applied to the tool for one second.
- During the single shot, compressed air is applied to each required cutting edge for half a second.
- When panoramic images are taken, compressed air is applied to the tool briefly at the beginning of imaging.

### Notes

- When you program single shots, the spindle angles of the cutting edges must be specified in the **VTC-TOOLS.TAB**.  
**Further information:** "VTC tool table", Page 25
- The profile view is intended for ball-nose cutters or toroid cutters with indexable inserts without twist.
- The panoramic image at camera 1 is suitable for cylindrical end mills.
- If you define a mosaic image to be taken by camera 2, then the camera will take multiple images of the bottom of the tool and automatically compose them into one sharp image.
- A VTC option is required for panoramic images with Cycle 622.

**Tool notes****Image from the side – camera 1**

<b>Tool type</b>	<b>Minimum tool diameter</b>	<b>Maximum tool diameter</b>	<b>R2</b>
Drill	0.2 mm	32 mm	-
End mill	0.2 mm	No limitation	-
Ball-nose cutter	0.2 mm	32 mm	-
Toroid cutter	0.2 mm	32 mm	<=16 mm

**Image from below – camera 2**

<b>Tool type</b>	<b>Minimum tool diameter</b>	<b>Maximum tool diameter</b>	<b>R2</b>
Drill	0.2 mm	32 mm	-
End mill	0.2 mm	No limitation	-
Ball-nose cutter	0.2 mm	32 mm	-
Toroid cutter	0.2 mm	32 mm	<=16 mm

- Depending on the tool, you have to save the following values in the tool table:
  - **R**
  - **L**
  - **R2**
  - **CUT** (This input is not needed for panoramic images.)
  - **T-ANGLE**
- **Further information:** "Things to keep in mind regarding VTC cycles", Page 24

## 5.4.1 Cycle parameters

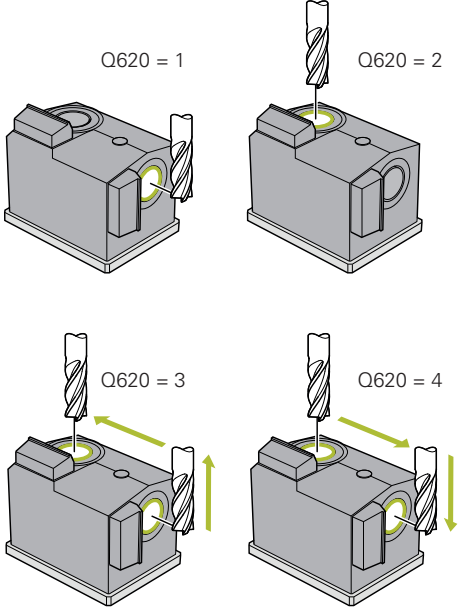
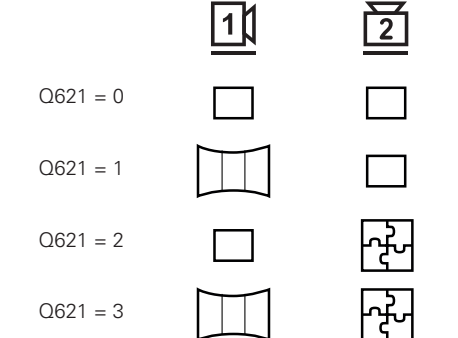
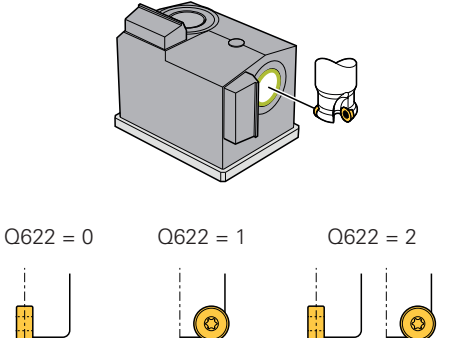
Help graphic	Parameter
	<p><b>QS610 Designation for the job</b> Name of the folder in which the images are stored in the tool evaluation. Input: Max. <b>255</b> characters</p>
	<p><b>Q620 Selection of the camera(s)</b> Selection of camera 1 or camera 2 <b>11</b>: Image is captured by camera 1 <b>22</b>: Image is captured by camera 2 <b>3</b>: Images are first captured by camera 1, and then by camera 2 <b>4</b>: Images are first captured by camera 2, and then by camera 1 Input: <b>1, 2, 3, 4</b></p> <p><b>Q621 Selection of image capture mode</b> Selection of single shot, panoramic image or mosaic image: <b>0</b>: Single shot on camera 1, single shot on camera 2 <b>1</b>: Panoramic image on camera 1, single shot on camera 2 <b>2</b>: Single shot on camera 1, mosaic image on camera 2 <b>3</b>: Panoramic image on camera 1, mosaic image on camera 2 Input: <b>0, 1, 2, 3</b></p>
	<p><b>Q622 Selection of view</b> Selection of plan view image or profile view image of the cutting edge. This process is repeated for each cutting edge stored. <b>0</b>: Plan view of single cutting edge. If <b>Q629=0</b>, the camera takes multiple images of the individual cutting edges on several focal planes. The VTC software composes the individual images into one sharp image. <b>1</b>: Profile view; the control rotates the tool by 90° and shifts the tool such that the camera's focus is on the profile of the cutting edge. The camera takes an image of the complete profile of the cutting edge. If the profile cannot be captured in one image, the control moves the tool in the machining plane and takes multiple images of the profile of the cutting edge. The VTC software composes the individual images into one sharp image. <b>2</b>: The camera takes an image of the plan view and then an image of the profile view of the individual cutting edges. See modes 0 and 1. This parameter is effective only for camera 1. Input: <b>0, 1, 2</b></p>

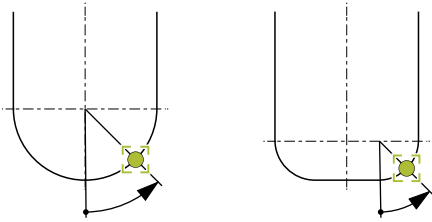
**Help graphic****Parameter****Q629 Contact angle at R/R2**

Using the contact angle, you define the point on the corner radius to which the camera will focus on the tool.

**>=1:** The control uses the defined contact angle to focus on the individual cutting edges.

**0:** No contact point; the control focuses on the lower cutting edge of the tool.

**-1: REF-ANGLE** value from the VTC tool table

This parameter is effective for ball-nose and toroid cutters only.

Input: **-1...90**

**Example**

11 TCH PROBE 622 IMAGES ~	
QS610="TEST"	;JOB NAME ~
Q620=+1	;CAMERA SELECTION ~
Q621=+0	;IMAGE CAPTURE MODE ~
Q622=+0	;SELECTION OF VIEW ~
Q629=+0	;CONTACT ANGLE

## 5.5 Cycle 623 BREAKAGE CHECK

### Application

Cycle **623 BREAKAGE CHECK** helps you to detect tool breakage. The control saves the result in parameter **Q601**. You can check cylindrical cutters, drills, ball-nose cutters, and toroid cutters for breakage.

#### Cycle sequence:

- 1 The control moves the tool to the clearance height and then positions it next to camera 1 on the outermost tool radius plus safety clearance.
- 2 The control switches on the spindle.
- 3 The VTC software compares the breakage check value with the **LBREAK** value from the control and checks whether the tool is broken or not. The control saves the result in **Q601**.
- 4 At the end of the cycle, the control positions the tool to the clearance height.
- 5 If the spindle revolution was active before the cycle call, the control restores this condition at the end of the cycle.

**i** The control moves ball-nose cutters, toroid cutters, and drills closer to the camera than cylindrical cutters:

- Ball-nose cutter: Closer to the camera by **R**
- Toroid cutter: Closer to the camera by **R2**
- Drill: Closer to the camera by **R**

#### Result parameters Q601:

Result	Meaning
-1	No result found
0	Tool is not broken
2	Tool is broken

#### Cleaning function

- Before the start of the cycle, the compressed-air jets on the two cameras are activated for two seconds.
- Before an image is taken, compressed air is applied directly to the tool for one second.

## Notes



Your machine manufacturer specifies whether your tool will be locked in case of breakage.

- If **LBREAK** is specified in the tool table, the breakage check can be performed on the tool.

### Tool notes

#### Breakage control

Tool type	Minimum tool diameter	Maximum tool diameter	R2
Drill	0.5 mm	32 mm	-
End mill	0.5 mm	No limitation	-
Ball-nose cutter	0.5 mm	32 mm	-
Toroid cutter	0.5 mm	32 mm	<=16 mm

- Depending on the tool, you have to save the following values in the tool table:
  - R
  - L
  - R2
  - **LBREAK**
- **Further information:** "Things to keep in mind regarding VTC cycles", Page 24

## 5.5.1 Cycle parameters

### Help graphic

### Parameter

Cycle **623** does not have a cycle parameter. Close cycle input with the **END** key.

### Example

```
11 TCH PROBE 623 BREAKAGE CHECK
```

### 5.5.2 Possible queries

The **BREAKAGE CHECK** cycle enters a value in parameter **Q601**.

The following values are possible:

- **Q601** = -1: No result
- **Q601** = 0: Tool not broken
- **Q601** = 2: Tool broken

Example showing a request of parameter **Q601**:

<b>0 BEGIN PGM 6 MM</b>	
<b>1 BLK FORM CYLINDER Z R42 L150</b>	Workpiece blank definition: cylinder
<b>2 FUNCTION MODE MILL</b>	Activate milling mode
<b>3 TOOL CALL 1 Z S4500</b>	
<b>4 L Z+250 R0 FMAX M3</b>	
<b>5 LBL 20</b>	
<b>6 TCH PROBE 623 BREAKAGE CHECK</b>	Define Cycle 623
<b>7 FN 9: IF +Q601 EQU -1 GOTO LBL 20</b>	If parameter Q601 = -1, then jump to LBL 20
<b>8 FN 9: IF +Q601 EQU +0 GOTO LBL 21</b>	If parameter Q601 = 0, then jump to LBL 21
<b>9 FN 9: IF +Q601 EQU +2 GOTO LBL 22</b>	If parameter Q601 = +2, then jump to LBL 22
<b>10 LBL 21</b>	Program the machining operation
...	
<b>57 LBL 22</b>	Definition of LBL 22
<b>58 STOP</b>	Program stop; the operator can inspect the tool
<b>59 LBL 0</b>	
<b>60 END PGM 6 MM</b>	

## 5.6 Cycle 624 MEASURING CUTTING EDGE ANGLES

### Application

Cycle **624 MEASURING CUTTING EDGE ANGLES** allows you to automatically determine the spindle angles of the cutting edges. The control enters them in the **VTC-TOOLS.TAB** table.

**Further information:** "VTC tool table", Page 25

The spindle angles of the cutting edges are needed for prepositioning in Cycle **621** and for the single shots and profile images in Cycle **622**. Cycle **624** is therefore recommended for every tool being used.

#### Cycle sequence:

- 1 The control moves the tool to the clearance height and then positions it above camera 2.
- 2 If a spindle revolution is activated, the control stops this movement.
- 3 The cycle automatically determines the spindle angles of the cutting edges.
- 4 The spindle angles are entered in the **VTC-TOOLS.TAB** table.
- 5 At the end of the cycle, the control positions the tool to the clearance height
- 6 If the spindle revolution was active before the cycle call, the control restores this condition at the end of the cycle.

#### Cleaning function

- Before the start of the cycle, the compressed-air jets on the two cameras are activated for two seconds.
- Before an image is taken, compressed air is applied directly to the tool for one second.
- During measurement of the spindle angles of the cutting edges, compressed air is applied to each successive cutting edge for half a second.

### Notes

- Measurement of the spindle angle of the cutting edges can be performed only with cylindrical, ball-nose, or toroid cutters.
- For optimum cutting edge measurement, HEIDENHAIN recommends programming a value between +30° and +60° in parameter **Q629 Contact angle** on ball-nose or toroid cutters.
- **Further information:** "Things to keep in mind regarding VTC cycles", Page 24

#### Tool notes

##### Image from below – camera 2

Tool type	Minimum tool diameter	Maximum tool diameter	R2
End mill	1.9 mm	No limitation	
Ball-nose cutter	1.9 mm	32 mm	
Toroid cutter	1.9 mm	32 mm	<=16 mm

- Depending on the tool, you have to save the following values in the tool table:
  - **R**
  - **L**
  - **R2**
  - **CUT**
- **Further information:** "Things to keep in mind regarding VTC cycles", Page 24

### 5.6.1 Cycle parameters

Help graphic	Parameter
	<p><b>Q625 Assign new tool ID</b></p> <p>In order to identify the tool in the tool evaluation, a tool ID number must have been assigned. This makes it possible to distinguish the tools. The tool ID numbers are stored in the <b>VTC-TOOLS.TAB</b> table.</p> <p><b>0:</b> If a tool ID number exists, the control will use it. If there is no tool ID number, the control adds a new line with the active tool and assigns a new tool ID number.</p> <p><b>1:</b> The control always generates a new tool ID number. If an ID number was already assigned for this tool, it is overwritten.</p> <p>Input: <b>0, 1</b></p> <p><b>Further information:</b> "VTC tool table", Page 25</p>

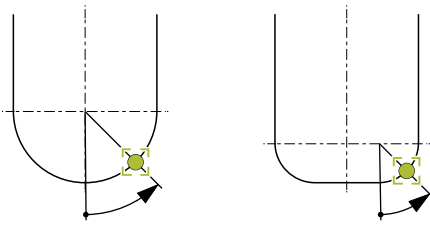

#### Q629 Contact angle at R/R2

Using the contact angle, you define the point on the tool radius **R** or **R2** to which the camera will focus on the tool and measure the cutting edge.

**>= 1:** The control uses the defined contact angle to focus on the individual cutting edges.

The control stores this value in the **REF-ANGLE** column of the VTC tool table.

This parameter is effective for ball-nose and toroid cutters only.

Input: **1...90**

#### Example

11 TCH PROBE 624 MEASUREMENT OF CUTTING EDGE ANGLE ~	
Q625=+0	;NEW TOOL ID ~
Q629=+30	;CONTACT ANGLE

## 5.7 Fundamentals of measuring cycles

### 5.7.1 General information

The VTC measuring cycles measure tools automatically. Lengths, radii, corner radii, point angles or compensation values are saved in the tool table and considered during further machining operations.

In order to precisely specify the actual values of the tools, you must calibrate the camera; otherwise the control cannot provide precise measuring results.

The control provides Cycle **625 VT CALIBRATION** for this purpose.

The control also features Cycle **626 TEMPERATURE COMPENSATION**. This cycle counteracts undesired temperature influences on the machine and compensates for temperature-related deviations. Temperature deviations may become evident through axial offsets, for example.

The reference tool provided by HEIDENHAIN allows you to calibrate the camera and determine the temperature compensation.

The following cycles are available for tool measurement:

- Cycle **627 TOOL LENGTH**
- Cycle **628 TOOL RADIUS**
- Cycle **629 TOOL RADIUS 2**
- Cycle **630 MEASURE TOOL**
- Cycle **631 MEASURE TOOL TIP**

#### Tool measurement cycle sequence

- 1 Pre-positioning
- 2 Measurement at the first measuring position



The control performs two measurements at each measuring position. For the second measurement, the control shifts the tool by one pixel. Based on these two values, the control determines the maximum value and then proceeds with this value.

- 3 Measurements are repeated, if necessary
- 4 Additional measuring positions are used, if necessary

## 5.8 Cycle 625 VT CALIBRATION

### Application

**i** HEIDENHAIN only guarantees the proper operation of the **VT CALIBRATION** cycle in conjunction with the HEIDENHAIN **VT 122** calibration tool. This calibration tool is available from HEIDENHAIN as an accessory.

Cycle **625 VT CALIBRATION** calibrates the **VT 122** vision system using a reference tool.

The coordinates of the vision system determined during calibration are coordinates in the machine coordinate system.

#### Requirements

Before you start the cycle, the camera must be measured. The control provides the following cycles for this purpose:

- Cycle **620 VT SETUP**

#### Cycle sequence

- 1 The control moves the reference tool to the clearance height and then positions it in the focal plane of camera 1. The focus is placed on the outermost tool radius of the reference tool.
- 2 The control switches on the spindle.
- 3 The control positions the reference tool in front of the camera based on **L-OFFS**.
- 4 The control performs the first calibration of the camera based on the tool radius. Depending on **Q633 REPEAT MEASUREMENTS**, the control repeats the calibration several times.
- 5 The control positions the reference tool in front of the camera based on **R-OFFS** and the length **L** from the tool table.
- 6 The control performs the second calibration of the camera by means of the tool axis. Depending on **Q633 REPEAT MEASUREMENTS**, the control repeats the calibration several times.
- 7 At the end of the cycle, the control positions the tool to the clearance height.
- 8 If the spindle revolution was active before the cycle call, the control restores this condition at the end of the cycle.

**Further information:** "Things to keep in mind regarding VTC cycles", Page 24

#### Cleaning function

- Before the start of the cycle, the compressed-air jets on the two cameras are activated for two seconds.
- Before the first measurement and before every repeated measurement, compressed air is applied to the tool for one second.

## Notes

- **VTC** cannot be run actively in combination with **Tilt working plane**.
- If the dispersion tolerance is exceeded, the control will interrupt machining with an error message.
- Use **R-OFFS** and **L-OFFS** to define the measuring position.

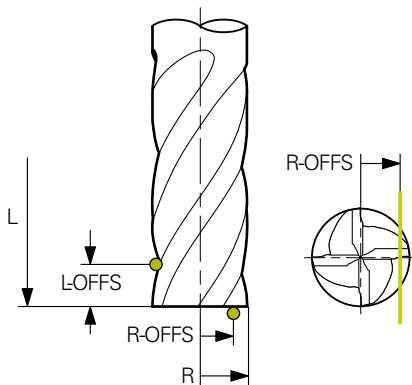

- The cycle searches for the tool based on the tool radius and the tool length. The cycle continues searching until **RBREAK** or **LBREAK** has been exceeded. If the value is exceeded, the control will display an error message.
- **Further information:** "Things to keep in mind regarding VTC cycles", Page 24

### Tool notes

- The reference tool must not be a drill or ball-nose cutter.
- Save the following values for the reference tool in the tool table:
  - Length **L**
  - Radius **R**
  - Offset **L-OFFS**
  - Offset **R-OFFS**
- Ensure that no **DL** and **DR** compensation values have been saved for the reference tool.

### 5.8.1 Cycle parameters

Help graphic	Parameter
	<p><b>Q633 Number of repeat measurements?</b></p> <p>Number of measurements that the cycle repeats at a measuring position.</p> <p>Input: <b>0...10</b></p>
	<p><b>Q634 Permitted dispersion tolerance?</b></p> <p>Input of the dispersion tolerance</p> <p>If repeat measurements <b>Q633&gt;0</b> are performed, the control will check whether the measurements are within the dispersion tolerance.</p> <p>Input: <b>0.001...0.099</b></p>

#### Example

11 TCH PROBE 625 VT 121 CALIBRATION -	
Q633=+2	;REPEAT MEASUREMENTS-
Q634=+0.03	;DISPERSION TOLERANCE

## 5.9 Cycle 626 TEMPERATURE COMPENSATION

### Application

Accuracy requirements are becoming increasingly stringent, particularly in the area of 5-axis machining. Complex parts are expected to be machined to exact specifications with reproducible accuracy over extended periods.

Cycle **626 TEMPERATURE COMPENSATION** counteracts undesired temperature influences on the machine and compensates for temperature-related deviations. Temperature deviations may become evident through axial offsets, for example.

To compensate for the deviations, first use a reference tool to make a reference measurement. The reference measurement corresponds to the current status of the machine.

To counteract the temperature influence over time, you can perform an additional measurement for comparison with the reference measurement. The control automatically compensates for the deviation during further measurements at the camera with Cycles **627** to **631**.

In addition, the control saves the deviations in the result parameters **Q115-Q117**. You can continue to use them in your NC program and offset them, for example, with the current datum.

The temperature compensation remains active until you execute Cycle **626 TEMPERATURE COMPENSATION** or Cycle **625 VT CALIBRATION** again. If the control is restarted and temperature compensation is active, the control displays a warning.

The coordinates of the vision system determined are coordinates in the machine coordinate system.

### Requirements

Before you start the cycle, the camera must be measured and calibrated. The control provides the following cycles for this purpose:

- Cycle **620 VT SETUP**
- Cycle **625 VT CALIBRATION**

**Cycle sequence**

- 1 The control moves the reference tool to the clearance height and then positions it in the focal plane of camera 1. The focus is placed on the outermost tool radius of the reference tool.
- 2 The control switches on the spindle.
- 3 The control positions the reference tool in front of the camera based on **R-OFFS** and **L-OFFS** from the tool table.
- 4 The control measures the tool.
- 5 Depending on **Q633 REPEAT MEASUREMENTS**, the control repeats the measurement several times.
- 6 At the end of the cycle, the control positions the tool to the clearance height.
- 7 If the spindle revolution was active before the cycle call, the control restores this condition at the end of the cycle.
- 8 The control saves the axial offsets measured relative to the reference measurement in the following Q parameters:

Q parameter number	Meaning
Q115	Deviation relative to the reference measurement in the machine coordinate system in the X axis.
Q116	Deviation relative to the reference measurement in the machine coordinate system in the Y axis.
Q117	Deviation relative to the reference measurement in the machine coordinate system in the Z axis.

**Further information:** "Things to keep in mind regarding VTC cycles", Page 24

**Cleaning function**

- Before the start of the cycle, the compressed-air jets on the two cameras are activated for two seconds.
- Before the first measurement and before every repeated measurement, compressed air is applied to the tool for one second.

**Notes**

- VTC cannot be run actively in combination with **Tilt working plane**.
- If the dispersion tolerance is exceeded, the control will interrupt machining with an error message.
- Use **R-OFFS** and **L-OFFS** to define the measuring position.

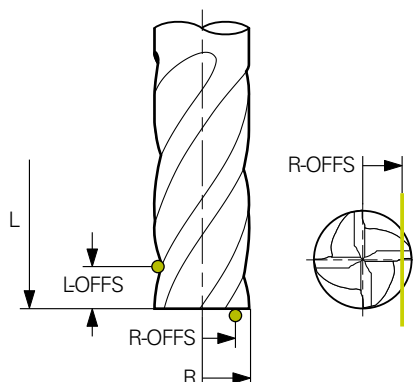

- **Further information:** "Things to keep in mind regarding VTC cycles", Page 24

**Tool notes**

- The reference tool must not be a drill or ball-nose cutter.
- Save the following values for the reference tool in the tool table:
  - Length **L**
  - Radius **R**
  - Offset **L-OFFS**
  - Offset **R-OFFS**
- Ensure that no **DL** and **DR** compensation values have been saved for the reference tool.

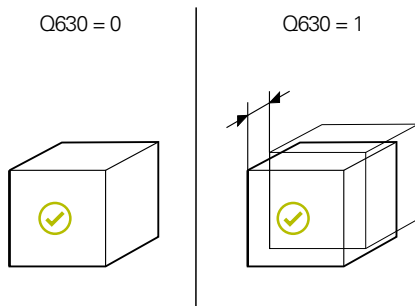
**5.9.1 Cycle parameters****Help graphic****Parameter****Q630 Compensation mode (0-1)?**

Selection of the mode:

**0:** Reference measurement—determining the current machine status.

**1:** Comparative measurement relative to the reference measurement—measuring deviations from the reference measurement (e.g., due to axial offset).

Input: **0, 1**

**Q633 Number of repeat measurements?**

Number of measurements that the cycle repeats at a measuring position.

Input: **0...10**

**Q634 Permitted dispersion tolerance?**

Input of the dispersion tolerance

If repeat measurements **Q633 > 0** are performed, the control will check whether the measurements are within the dispersion tolerance.

Input: **0.001...0.099**

**Example**

11 TCH PROBE 626 TEMPERATURE COMPENSATION ~	
Q630=+0	;MODE SELECTION ~
Q633=+2	;REPEAT MEASUREMENTS ~
Q634=+0.03	;DISPERSION TOLERANCE

## 5.10 Cycle 627 TOOL LENGTH

### Application

Cycle **627 TOOL LENGTH** determines the length of a tool.

#### Requirements

Before you start the cycle, the camera must be measured and calibrated. The control provides the following cycles for this purpose:

- Cycle **620 VT SETUP**
- Cycle **625 VT CALIBRATION**

#### Cycle sequence

- 1 The control moves the tool to the clearance height and then positions it in the focal plane of camera 1. The focus is placed on the outermost tool radius of the tool.
- 2 The control switches on the spindle.
- 3 The control positions the tool in front of the camera based on **R-OFFS** from the tool table.
- 4 Depending on **Q639**, the control first performs an initial measurement.
- 5 The control measures the tool.
- 6 Depending on **Q633 REPEAT MEASUREMENTS**, the control repeats the measurement several times.
- 7 At the end of the cycle, the control positions the tool to the clearance height.
- 8 If the spindle revolution was active before the cycle call, the control restores this condition at the end of the cycle.
- 9 The control saves the measured value and the status in the following Q parameters:

Q parameter number	Meaning
<b>Q115</b>	Deviation from the current tool radius – delta length <b>DL</b> + measured deviation
<b>Q601</b>	Tool status: <ul style="list-style-type: none"> <li>■ <b>-1</b> = Measurement failed</li> <li>■ <b>0</b> = Measurement OK</li> <li>■ <b>1</b> = Wear tolerance reached</li> <li>■ <b>2</b> = Tool breakage</li> </ul>

**Further information:** "Things to keep in mind regarding VTC cycles", Page 24

#### Cleaning function

- Before the start of the cycle, the compressed-air jets on the two cameras are activated for two seconds.
- Before the first measurement and before every repeated measurement, compressed air is applied to the tool for one second.

### Measuring tools with 0 length



Refer to your machine manual!

The machine manufacturer can define a maximum tool length for the tool measurement cycles in the **VTC.tab**.



HEIDENHAIN recommends that you always define tools with their actual tool length if possible.

The cycle measures the tool length automatically. You can also measure tools defined with a length L of 0 in the tool table. To do this, the machine manufacturer must define a maximum tool length value. Furthermore you have to save the radius **R**, **R2** (if available) and **T-ANGLE** (if available) in the tool table. The control starts a search in which the actual tool length is roughly determined in the first step. Subsequently, a fine measurement is realized.

### NOTICE

#### Danger of collision!

If the machine manufacturer fails to define the maximum tool length, no tool search will be run. The control pre-positions the tool with a length of 0. Risk of collision!

- ▶ Refer to your machine manual.
- ▶ Define tools with the actual tool length **L**

### NOTICE

#### Danger of collision!

Risk of collision if the tool is longer than the maximum length defined by the machine manufacturer.

- ▶ Refer to your machine manual.

### Notes

- VTC cannot be run actively in combination with **Tilt working plane**.
- If the dispersion tolerance is exceeded, the control will interrupt machining with an error message.
- Use **R-OFFS** to define the measuring position.

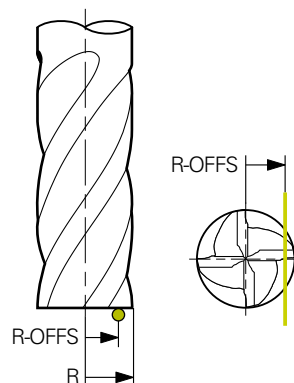

- **Further information:** "Things to keep in mind regarding VTC cycles", Page 24

**Tool notes****Measuring length**

<b>Tool type</b>	<b>Minimum tool diameter</b>	<b>Maximum tool diameter</b>	<b>R2</b>
Drill	1 mm	32 mm	-
End mill	1 mm	100 mm	-
Ball-nose cutter	1 mm	32 mm	-
Toroid cutter	1 mm	32 mm	<=16 mm

- Depending on the tool type, you have to save the following values for the tool in the tool table:
  - **L**
  - **R**
  - **R2**
  - **LTOL**
  - **R-OFFS**

### 5.10.1 Cycle parameters

Help graphic	Parameter
	<p><b>Q632 Tool measurement mode (0-2)?</b></p> <p>The cycle offers the following options for writing the measured length value to the tool table or in the Q parameter:</p> <p><b>0:</b> The control transfers the value into the <b>L</b> column. The control resets the existing delta value in the <b>DL</b> column.</p> <p><b>1:</b> The control enters the delta value in columns <b>DL</b> and <b>Q115</b>. To determine the delta value, the control compares the measured tool length with the tool length entered in the tool table. The control monitors the wear and breakage tolerance and locks the tool, if necessary.</p> <p><b>2:</b> The control enters the delta value in <b>Q115</b>. To determine the delta value, the control compares the measured tool length with the tool length entered in the tool table. The control monitors the wear and breakage tolerance and locks the tool, if necessary.</p> <p>Input: <b>0, 1, 2</b></p>
	<p><b>Q633 Number of repeat measurements?</b></p> <p>Number of measurements that the cycle repeats at a measuring position.</p> <p>Input: <b>0...10</b></p>
	<p><b>Q634 Permitted dispersion tolerance?</b></p> <p>Input of the dispersion tolerance</p> <p>If repeat measurements <b>Q633&gt;0</b> are performed, the control will check whether the measurements are within the dispersion tolerance.</p> <p>Input: <b>0.001...0.099</b></p>
	<p><b>Q639 Additional initial measurement (0-1)?</b></p> <p>Define whether an initial measurement with a larger measuring range is performed before the actual measurement of the tool length</p> <p><b>0:</b> The control does not perform an initial measurement. The tool length was already determined in advance and is saved in the tool table <b>TOOL.T</b>.</p> <p><b>1:</b> The control first performs an initial measurement. The tool length was determined approximately and is saved in the tool table <b>TOOL.T</b>.</p> <p>Input: <b>0, 1</b></p>

#### Example

11 TCH PROBE 627 TOOL LENGTH ~	
Q630=+0	;MODE SELECTION ~
Q633=+1	;REPEAT MEASUREMENTS ~
Q634=+0.03	;DISPERSION TOLERANCE ~
Q639=+0	;INITIALMESSUNG

## 5.11 Cycle 628 TOOL RADIUS

### Application

Cycle **628 TOOL RADIUS** determines the radius of a tool.

#### Requirements

Before you start the cycle, the camera must be measured and calibrated. The control provides the following cycles for this purpose:

- Cycle **620 VT SETUP**
- Cycle **625 VT CALIBRATION**

#### Cycle sequence

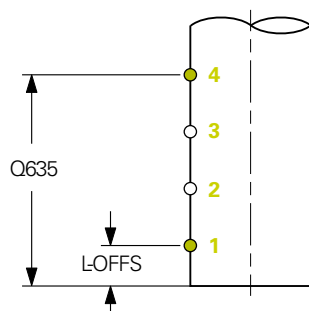

- 1 The control moves the tool to the clearance height and then positions it in the focal plane of camera 1. The focus is placed on the outermost tool radius of the tool.
- 2 The control switches on the spindle.
- 3 The control positions the tool in front of the camera based on **L-OFFS** from the tool table.
- 4 The control measures the tool radius at the starting point **1**. The starting point is at the height of **L-OFFS**.
- 5 If you define **Q633 REPEAT MEASUREMENTS**, the control repeats the measurement at the same measuring position several times.
- 6 Depending on the definition of **Q636 NO. MEASURING POINTS**, further measurements will be performed. These are distributed evenly on the length of **Q635** between the start point and the end point (measuring points **2** and **3**). Depending on the definition, step 5 repeats itself at every measurement position.
- 7 Finally, the control measures the tool at the end point **4**. The end point is at the height of **Q635 MEAS. LENGTH ENTRY**: Depending on the definition of **Q633**, the process repeats itself in step 5.
- 8 At the end of the cycle, the control positions the tool to the clearance height.
- 9 If the spindle revolution was active before the cycle call, the control restores this condition at the end of the cycle.
- 10 The control saves the measured value based on **Q632 MODE SELECTION** and the status in the following Q parameters:

Q parameter number	Meaning
Q116	Deviation from the current tool radius – delta radius <b>DR</b> + measured deviation
Q601	Tool status: <ul style="list-style-type: none"> <li>■ <b>-1</b> = Measurement failed</li> <li>■ <b>0</b> = Measurement OK</li> <li>■ <b>1</b> = Wear tolerance reached</li> <li>■ <b>2</b> = Tool breakage</li> </ul>

**Further information:** "Things to keep in mind regarding VTC cycles", Page 24

#### Cleaning function

- Before the start of the cycle, the compressed-air jets on the two cameras are activated for two seconds.
- Before the first measurement and before every repeated measurement, compressed air is applied to the tool for one second.

#### Notes

- **VTC** cannot be run actively in combination with **Tilt working plane**.
- If the parameter **Q636 MEAS. LENGTH ENTRY** is not equal to 0 and less than **L-OFFS**, the control will display an error message.
- If the dispersion tolerance is exceeded, the control will interrupt machining with an error message.
- **Further information:** "Things to keep in mind regarding VTC cycles", Page 24

#### Tool notes

##### Measuring the radius

Tool type	Minimum tool diameter	Maximum tool diameter	R2
Drill	1 mm	100 mm	-
End mill	1 mm	100 mm	-
Ball-nose cutter	1 mm	32 mm	-
Toroid cutter	1 mm	32 mm	<=16 mm

- Depending on the tool type, you have to save the following values for the tool in the tool table:
  - **L**
  - **R**
  - **R2**
  - **RTOL**
  - **L-OFFS**

### 5.11.1 Cycle parameters

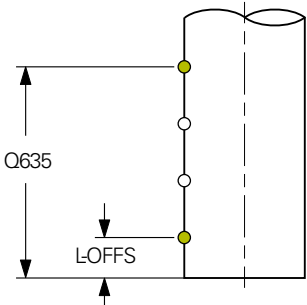
Help graphic	Parameter
	<p><b>Q632 Tool measurement mode (0-2)?</b></p> <p>The cycle offers the following options for writing the measured radius value to the tool table or in the Q parameters:</p> <p><b>0:</b> The control transfers the value into the <b>R</b> column. The control resets the existing delta value in the <b>DR</b> column.</p> <p><b>1:</b> The control enters the delta value in columns <b>DR</b> and <b>Q116</b>. To determine the delta value, the control compares the measured tool radius with the tool radius entered in the tool table. The control monitors the wear and breakage tolerance and locks the tool, if necessary.</p> <p><b>2:</b> The control enters the delta value in <b>Q116</b>. To determine the delta value, the control compares the measured tool radius with the tool radius entered in the tool table. The control monitors the wear and breakage tolerance and locks the tool, if necessary.</p> <p>Input: <b>0, 1, 2</b></p>
	<p><b>Q633 Number of repeat measurements?</b></p> <p>Number of measurements that the cycle repeats at a measuring position.</p> <p>Input: <b>0...10</b></p>
	<p><b>Q634 Permitted dispersion tolerance?</b></p> <p>Input of the dispersion tolerance</p> <p>If repeat measurements <b>Q633&gt;0</b> are performed, the control will check whether the measurements are within the dispersion tolerance.</p> <p>Input: <b>0.001...0.099</b></p>
	<p><b>Q635 Measurement length?</b></p> <p>The measurement length defines the area within which the control will capture further measuring points in order to measure the tool radius. The additional measuring points are distributed evenly on the length of <b>Q635</b> between the start point and the end point. At the same time, the measurement length defines the height of the last measuring point.</p> <p>The measurement length starts at the bottom edge of the tool. The bottom edge corresponds to the tool length <b>L</b> from the tool table.</p> <p><b>0:</b> The control performs a measurement at <b>L-OFFS</b>.</p> <p>Input: <b>0...100</b></p>

## Help graphic

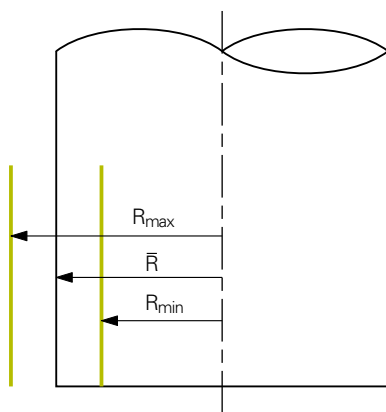
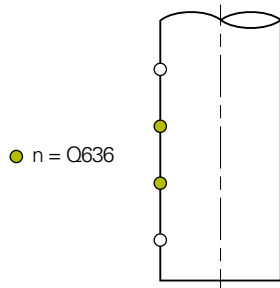

## Parameter

**Q636 Measurement points?**

Number of measuring points that the cycle additionally captures between the start and end point.

**0:** The control measures only the start point and the end point.

**1-30:** The control measures additional points between the start point and the end point and distributes them evenly.

Input: **0...30**

**Q637 Evaluation mode (0-2)?**

Behavior of the evaluation with multiple measuring points:

**0:** The control evaluates the maximum radius of all measuring points.

**1:** The control evaluates the minimum radius of all measuring points.

**2:** The control generates a mean value from all measured radii.

The parameter is effective only if **Q635>0**.

Input: **0, 1, 2**

## Example

11 TCH PROBE 628 TOOL RADIUS ~	
Q630=+0	;MODE SELECTION ~
Q633=+2	;REPEAT MEASUREMENTS ~
Q634=+0.03	;DISPERSION TOLERANCE ~
Q635=+0	;MEAS. LENGTH ENTRY ~
Q636=+0	;NO. MEASURING POINTS ~
Q637=+0	;EVALUATE

## 5.12 Cycle 629 TOOL RADIUS 2

### Application

Cycle **629 TOOL RADIUS 2** determines the corner radius of a tool. Based on the measured corner radius, the control calculates the length and radius and corrects them depending on the definition.

**i** Run this cycle only if the tool is being used for operations at a defined contact angle.

### Requirements

Before you start the cycle, the camera must be measured and calibrated. The control provides the following cycles for this purpose:

- Cycle **620 VT SETUP**
- Cycle **625 VT CALIBRATION**

### Cycle sequence

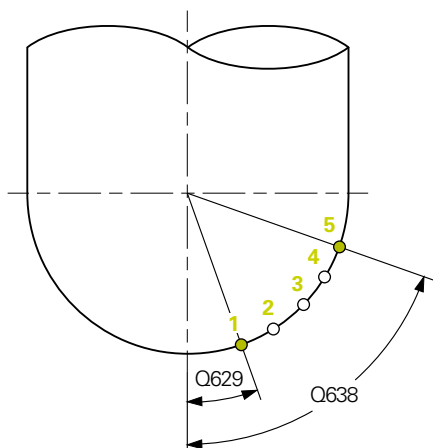

- 1 The control moves the tool to the clearance height and then positions it in the focal plane of camera 1. The focus is placed on the outermost tool radius of the tool.
- 2 The control switches on the spindle.
- 3 The control positions the tool in front of the camera based on **Q629 CONTACT ANGLE**.
- 4 The control measures the tool radius at the starting point **1**. The starting point is at the height of **Q629 CONTACT ANGLE**.
- 5 If you define **Q633 REPEAT MEASUREMENTS**, the control repeats the measurement at the same measuring position several times.
- 6 Depending on the definition of **Q636 NO. MEASURING POINTS**, further measurements will be performed. These are distributed evenly on the length of **Q638** between the start point and the end point (measuring points **2 to 4**). Depending on the definition, step 5 repeats itself at every measuring point.
- 7 Finally, the control measures the tool at the end point **5**. The end point is at the height of **Q638 MEASURING ANGLE LENGTH**: Depending on the definition of **Q633**, the process repeats itself in step 5.
- 8 At the end of the cycle, the control positions the tool to the clearance height.

- 9 If the spindle revolution was active before the cycle call, the control restores this condition at the end of the cycle.
- 10 The control saves the measured value based on **Q632 MODE SELECTION** and the status in the following Q parameters:

Q parameter number	Meaning
Q115	Deviation from the current tool length – delta length <b>DL</b> + measured deviation
Q116	Deviation from the current tool radius – delta radius <b>DR</b> + measured deviation
Q117	Deviation from the current tool radius 2 – delta radius 2 <b>DR2</b> + measured deviation
Q601	Tool status: <ul style="list-style-type: none"> <li>■ <b>-1</b> = Measurement failed</li> <li>■ <b>0</b> = Measurement OK</li> <li>■ <b>1</b> = Wear tolerance reached</li> <li>■ <b>2</b> = Tool breakage</li> </ul>

**Further information:** "Things to keep in mind regarding VTC cycles", Page 24

#### Cleaning function

- Before the start of the cycle, the compressed-air jets on the two cameras are activated for two seconds.
- Before the first measurement and before every repeated measurement, compressed air is applied to the tool for one second.

## Notes

### NOTICE

#### Caution: Danger to the workpiece and tool!

The length, radius and delta values are not measured. The control calculates them based on the contact angle and the corner radius. Owing to this, the length, radius and delta values may differ from the actual values. This may result in damage to the tool or the workpiece!

- ▶ Check the length, radius and delta values after the cycle sequence
- ▶ HEIDENHAIN recommends the evaluation mode **Q632 = 2**

- **VTC** cannot be run actively in combination with **Tilt working plane**.
- If the parameter **Q636 MEAS. LENGTH ENTRY** is not equal to 0 and less than **Q629 CONTACT ANGLE**, the control will display an error message.
- If the dispersion tolerance is exceeded, the control will interrupt machining with an error message.
- **Further information:** "Things to keep in mind regarding VTC cycles", Page 24

**Tool notes**

<b>Tool type</b>	<b>Minimum tool diameter</b>	<b>Maximum tool diameter</b>	<b>R2</b>
Ball-nose cutter	1 mm	32 mm	-
Toroid cutter	1 mm	32 mm	<=16 mm

- Depending on the tool type, you have to save the following values for the tool in the tool table:
  - **L**
  - **R**
  - **R2**
  - **R2TOL**
  - **L-OFFS**

### 5.12.1 Cycle parameters

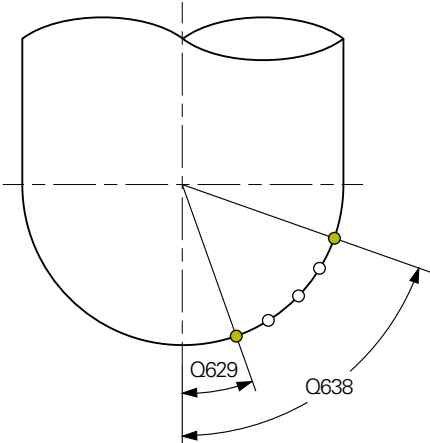
Help graphic	Parameter
	<p><b>Q632 Tool measurement mode (0-2)?</b></p> <p>The cycle offers the following options for writing the measured values for the length, radius and corner radius <b>R2</b> to the tool table or in the Q parameters:</p> <p><b>0:</b> The control transfers the values into the <b>L, R</b> and <b>R2</b> columns. The control resets any existing delta values in the <b>DL, DR</b> and <b>DR2</b> columns.</p> <p><b>1:</b> The control enters the delta values in columns <b>DL, DR</b> and <b>DR2</b> as well as in <b>Q115, Q116</b> and <b>Q117</b>. To determine the delta values, the control compares the measured values with the existing values in the tool table. The control monitors the wear and breakage tolerance and locks the tool, if necessary.</p> <p><b>2:</b> The control enters the delta values in <b>Q115, Q116</b> and <b>Q117</b>. To determine the delta values, the control compares the measured values with the existing values in the tool table. The control monitors the wear and breakage tolerance and locks the tool, if necessary.</p> <p>Input: <b>0, 1, 2</b></p>
	<p><b>Q633 Number of repeat measurements?</b></p> <p>Number of measurements that the cycle repeats at a measuring position.</p> <p>Input: <b>0...10</b></p>
	<p><b>Q634 Permitted dispersion tolerance?</b></p> <p>Input of the dispersion tolerance</p> <p>If repeat measurements <b>Q633&gt;0</b> are performed, the control will check whether the measurements are within the dispersion tolerance.</p> <p>Input: <b>0.001...0.099</b></p>
 <p>The diagram shows a cross-section of a tool with a rounded corner. A vertical dashed line represents the tool's axis. A horizontal dashed line represents the cutting edge. The corner is defined by a quarter-circle arc. Two yellow dots mark the start and end of the measuring angle. A curved arrow labeled Q638 indicates the measuring angle length. A straight arrow labeled Q629 indicates the contact angle at the start point.</p>	<p><b>Q629 Contact angle at R2</b></p> <p>The contact angle defines the start point on the corner radius <b>R2</b> to which the camera will focus on the tool and perform the measurement.</p> <p><b>0:</b> No contact point; the control focuses on the lower cutting edge of the tool.</p> <p>Input: <b>0...90</b></p>
	<p><b>Q638 Measuring angle length?</b></p> <p>The measuring angle defines the area within which the control will capture further measuring points in order to measure the corner radius. The additional measuring points are distributed evenly on the angle of <b>Q638</b> between the start point and the end point. At the same time, the measuring angle also defines the position of the last measuring point.</p> <p><b>0:</b> The control performs a measurement at the <b>Q629 CONTACT ANGLE</b></p> <p>Input: <b>0...90</b></p>

## Help graphic

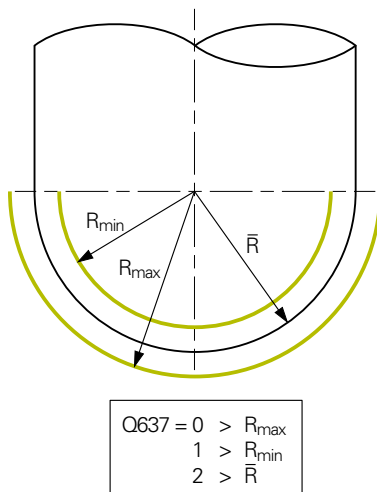
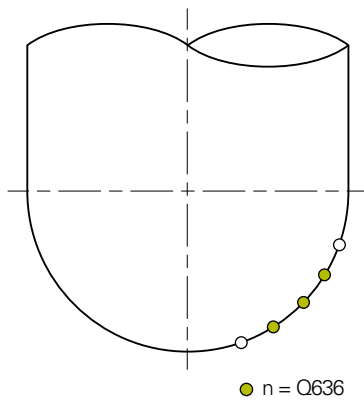

## Parameter

**Q636 Measurement points?**

Number of measuring points that the cycle additionally captures between the start and end point.

**0:** The control measures only the start point and the end point.

**1-30:** The control measures additional points between the start point and the end point and distributes them evenly.

Input: **0...30**

**Q637 Evaluation mode (0-2)?**

Behavior of the evaluation with multiple measuring points:

**0:** The control evaluates the maximum **R2** of all measuring points.

**1:** The control evaluates the minimum **R2** of all measuring points.

**2:** The control generates a mean value from all measured **R2** radii.

The parameter is effective only if **Q638>0**.

Input: **0, 1, 2**

## Example

11 TCH PROBE 629 TOOL RADIUS 2 ~	
Q630=+0	;MODE SELECTION ~
Q633=+1	;REPEAT MEASUREMENTS ~
Q634=+0.03	;DISPERSION TOLERANCE ~
Q629=+30	;CONTACT ANGLE ~
Q638=+80	;MEASURING ANGLE ~
Q636=+0	;NO. MEASURING POINTS ~
Q637=+0	;EVALUATE

## 5.13 Cycle 630 MEASURE TOOL

### Application

Cycle **630 MEASURE TOOL** measures a tool completely with the **VT 122** vision system.

#### Requirements

Before you start the cycle, the camera must be measured and calibrated. The control provides the following cycles for this purpose:

- Cycle **620 VT SETUP**
- Cycle **625 VT CALIBRATION**

#### Cycle sequence

- 1 The control moves the tool to the clearance height and then positions it in the focal plane of camera 1. The focus is placed on the outermost tool radius of the tool.
- 2 The control switches on the spindle.
- 3 The control positions the tool in front of the camera based on **R-OFFS** from the tool table.
- 4 Depending on **Q639**, the control first performs an initial measurement.
- 5 The control measures the tool length. Depending on the definition of **Q633 REPEAT MEASUREMENTS**, the control repeats the measurement several times.
- 6 The control positions the tool in front of the camera based on **L-OFFS** from the tool table and measures the radius. Depending on the definition of **Q633 REPEAT MEASUREMENTS**, the control repeats the measurement several times.
- 7 At the end of the cycle, the control positions the tool to the clearance height.
- 8 If the spindle revolution was active before the cycle call, the control restores this condition at the end of the cycle.
- 9 The control saves the measured value based on **Q632 MODE SELECTION** and the status in the following Q parameters:

Q parameter number	Meaning
Q115	Deviation from the current tool length – delta length <b>DL</b> + measured deviation
Q116	Deviation from the current tool radius – delta radius <b>DR</b> + measured deviation
Q601	Tool status: <ul style="list-style-type: none"> <li>■ <b>-1</b> = Measurement failed</li> <li>■ <b>0</b> = Measurement OK</li> <li>■ <b>1</b> = Wear tolerance reached</li> <li>■ <b>2</b> = Tool breakage</li> </ul>

**Further information:** "Things to keep in mind regarding VTC cycles", Page 24

#### Cleaning function

- Before the start of the cycle, the compressed-air jets on the two cameras are activated for two seconds.
- Before the first measurement and before every repeated measurement, compressed air is applied to the tool for one second.

## Notes

- VTC cannot be run actively in combination with **Tilt working plane**.
- If the dispersion tolerance is exceeded, the control will interrupt machining with an error message.
- Use **R-OFFS** and **L-OFFS** to define the measuring position.

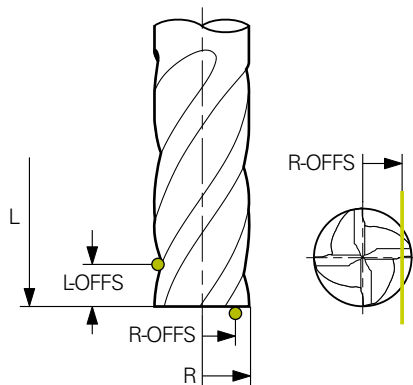

- **Further information:** "Things to keep in mind regarding VTC cycles", Page 24

### Tool notes

#### Measuring the radius

Tool type	Minimum tool diameter	Maximum tool diameter	R2
Drill	1 mm	100 mm	-
End mill	1 mm	100 mm	-
Ball-nose cutter	1 mm	32 mm	-
Toroid cutter	1 mm	32 mm	<=16 mm

#### Measuring length

Tool type	Minimum tool diameter	Maximum tool diameter	R2
Drill	1 mm	32 mm	-
End mill	1 mm	100 mm	-
Ball-nose cutter	1 mm	32 mm	-
Toroid cutter	1 mm	32 mm	<=16 mm

- Depending on the tool type, you have to save the following values for the tool in the tool table:
  - **L**
  - **R**
  - **R2**
  - **RTOL**
  - **LTOL**
  - **L-OFFS**
  - **R-OFFS**

### 5.13.1 Cycle parameters

Help graphic	Parameter
	<p><b>Q632 Tool measurement mode (0-2)?</b></p> <p>The cycle offers the following options for writing the measured values for the length and radius to the tool table or in the Q parameters:</p> <p><b>0:</b> The control transfers the values into the <b>L</b> and <b>R</b> columns. The control resets existing delta values in the <b>DL</b> and <b>DR</b> columns.</p> <p><b>1:</b> The control enters the delta values in columns <b>DL</b> and <b>DR</b> as well as in <b>Q115</b> and <b>Q116</b>. To determine the delta values, the control compares the measured values with the existing values in the tool table. The control monitors the wear and breakage tolerance and locks the tool, if necessary.</p> <p><b>2:</b> The control enters the delta values in <b>Q115</b> and <b>Q116</b>. To determine the delta values, the control compares the measured values with the existing values in the tool table. The control monitors the wear and breakage tolerance and locks the tool, if necessary.</p> <p>Input: <b>0, 1, 2</b></p>
	<p><b>Q633 Number of repeat measurements?</b></p> <p>Number of measurements that the cycle repeats at a measuring position.</p> <p>Input: <b>0...10</b></p>
	<p><b>Q634 Permitted dispersion tolerance?</b></p> <p>Input of the dispersion tolerance</p> <p>If repeat measurements <b>Q633&gt;0</b> are performed, the control will check whether the measurements are within the dispersion tolerance.</p> <p>Input: <b>0.001...0.099</b></p>
	<p><b>Q639 Additional initial measurement (0-1)?</b></p> <p>Define whether an initial measurement with a larger measuring range is performed before the actual measurement of the tool length</p> <p><b>0:</b> The control does not perform an initial measurement. The tool length was already determined in advance and is saved in the tool table <b>TOOL.T</b>.</p> <p><b>1:</b> The control first performs an initial measurement. The tool length was determined approximately and is saved in the tool table <b>TOOL.T</b>.</p> <p>Input: <b>0, 1</b></p>

#### Example

11 TCH PROBE 630 MEASURE TOOL ~	
Q630=+0	;MODE SELECTION ~
Q633=+2	;REPEAT MEASUREMENTS ~
Q634=+0.03	;DISPERSION TOLERANCE ~
Q639=+0	;INITIALMESSUNG

## 5.14 Cycle 631 MEASURE TOOL TIP

### Application

Cycle **631 MEASURE TOOL TIP** measures the point angle **T-ANGLE** and the tool length, if required.

#### Requirements

Before you start the cycle, the camera must be measured and calibrated. The control provides the following cycles for this purpose:

- Cycle **620 VT SETUP**
- Cycle **625 VT CALIBRATION**

#### Cycle sequence

- 1 The control moves the tool to the clearance height and then positions it in the focal plane of camera 1. The focus is placed on the outermost tool radius of the tool.
- 2 The control switches on the spindle.
- 3 The control positions the tool in front of the camera based on mode **Q631** and performs the first measurement. The first measurement position is at **R-OFFS** or at a calculated position next to the tool tip.
- 4 Depending on **Q633 REPEAT MEASUREMENTS**, the control repeats the measurement several times.
- 5 The control performs a second measurement to determine the point angle **T-ANGLE**. The measuring position is within the cylindrical area of the tool. Depending on **Q633** step 4 is repeated.
- 6 If you have defined the measurement of the tool length, the cycle will perform another measurement. Depending on **Q633** step 4 is repeated.
- 7 At the end of the cycle, the control positions the tool to the clearance height.
- 8 If the spindle revolution was active before the cycle call, the control restores this condition at the end of the cycle.

**Further information:** "Things to keep in mind regarding VTC cycles", Page 24

#### Cleaning function

- Before the start of the cycle, the compressed-air jets on the two cameras are activated for two seconds.
- Before the first measurement and before every repeated measurement, compressed air is applied to the tool for one second.

### Notes



- VTC cannot be run actively in combination with **Tilt working plane**
- If the dispersion tolerance is exceeded, the control will interrupt machining with an error message.
- **Further information:** "Things to keep in mind regarding VTC cycles", Page 24

**Tool notes**

<b>Tool type</b>	<b>Minimum tool diameter</b>	<b>Maximum tool diameter</b>
Drill	1 mm	32 mm

- The following tool values must be saved in the tool table:
  - **L**
  - **R**
  - **R-OFFS** (optional)

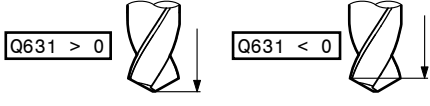
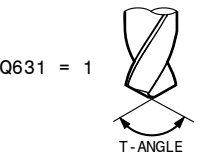
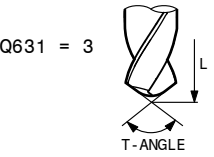
## 5.14.1 Cycle parameters

Help graphic	Parameter
	<p><b>Q631 Tip measurement mode (0-4)?</b></p>
	<p>Define the position at which the cycle will measure the tool:</p>
	<p><b>+/-1:</b> Measure point angle <b>T-ANGLE</b> on the tool</p>
	<p><b>+/-2:</b> Measure wear on <b>R-OFFS</b>. Use <b>R-OFFS</b> to define the measuring position.</p>
	<p><b>+/-3:</b> Measure the point angle <b>T-ANGLE</b> and the length of the theoretical tips.</p>
	<p><b>+/-4:</b> Measure the point angle <b>T-ANGLE</b> and the length of cylindrical part of the tool</p>
	<p>With the algebraic sign <b>+/-</b>, you define how the tool is currently measured and saved:</p>
	<ul style="list-style-type: none"> <li>■ <b>+</b>: The tool is currently measured based on the theoretical tool tip.</li> <li>■ <b>-</b>: The tool is currently measured based on the length of the cylindrical part of the tool.</li> </ul>
	<p>Input: <b>-4, -3, -2, -1, +1, +2, +3, +4</b></p>
	<p><b>Q632 Tool measurement mode (0-2)?</b></p>
	<p>The cycle offers the following options for writing the measured values for the length and point angle <b>T-ANGLE</b> to the tool table or in the Q parameters:</p>
	<p><b>0:</b> The control transfers the values into the <b>L</b> and <b>T-ANGLE</b> columns. The control resets the existing delta values in the DL column.</p>
	<p><b>1:</b> The control enters the delta value in columns <b>DL</b> and <b>Q115</b>. To determine the delta value, the control compares the measured length with the existing length in the tool table. The control saves the point angle directly in the <b>T-ANGLE</b> column. The control monitors the wear and breakage tolerance and locks the tool if necessary.</p>
	<p><b>2:</b> The control enters the delta value in <b>Q115</b>. To determine the delta value, the control compares the measured length with the existing length in the tool table. The control monitors the wear and breakage tolerance and locks the tool, if necessary.</p>
	<p>Input: <b>0, 1, 2</b></p>
	<p><b>Q633 Number of repeat measurements?</b></p>
	<p>Number of measurements that the cycle repeats at a measuring position.</p>
	<p>Input: <b>0...10</b></p>

**Help graphic****Parameter****Q634 Permitted dispersion tolerance?**

Input of the dispersion tolerance

If repeat measurements **Q633>0** are performed, the control will check whether the measurements are within the dispersion tolerance.

Input: **0.001...0.099**

**Example**

11 TCH PROBE 631 TOOL TIP ~	
Q631=+0	;MODE ~
Q632=+1	;MODE SELECTION ~
Q633=+2	;REPEAT MEASUREMENTS ~
Q634=+0.03	;DISPERSION TOLERANCE

# 6

**Basic operation**

## 6.1 Overview

This chapter describes the user interface, operating elements and basic functions of the software.

## 6.2 User interface

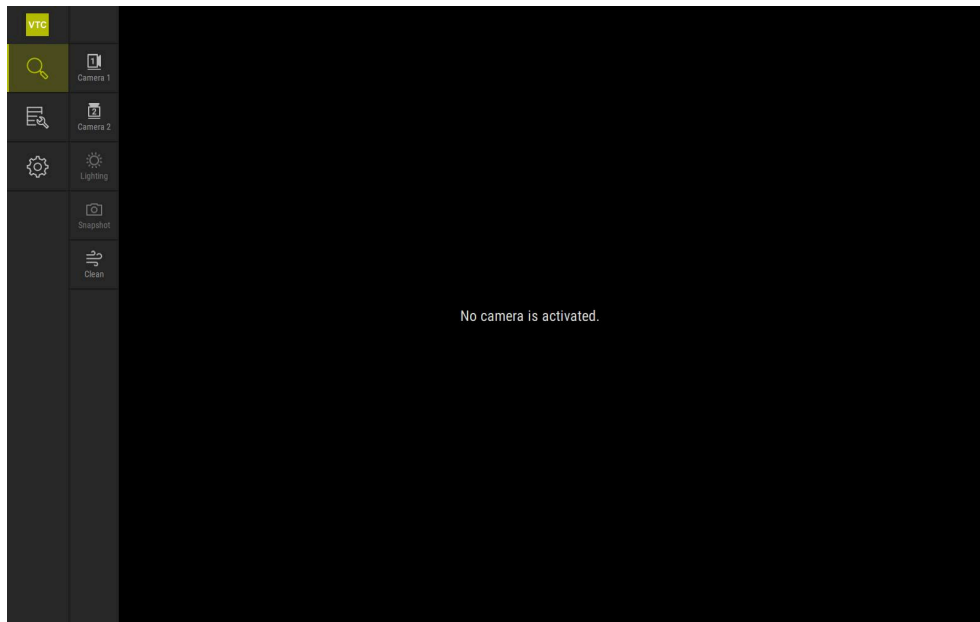





Figure 1: Main menu of the user interface

### Main menu operating elements

Operating element	Function
	<p><b>Manual tool inspection</b></p> <p>Live image of the tool with choice of camera, lighting control by means of the lighting palette and taking of single shots and panoramic images</p>
	<p><b>Tool evaluation</b></p> <p>Overview of the images taken and evaluation of the tool condition</p>
	<p><b>Settings</b></p> <p>Settings of the product, such as software configuration or enabling of software options</p>

### 6.3 Operation with touchscreen and gestures



The user interface of the VTC software is operated with gestures on the touchscreen or with a connected mouse.

To enter data, you can use the screen keyboard of the touchscreen.

**i** The gestures for operating the touchscreen may differ from the gestures for operating the mouse.

If the gestures for operating the touchscreen differ from those for operating the mouse, then these instructions describe both operating options as alternative actions.

The alternative actions for operating the touchscreen or the mouse are identified by the following symbols:

	Operation using the touchscreen
	Operation using the mouse

The following overview describes the different gestures for operating the touchscreen or the mouse:

---

#### Tapping

---



Means touching the screen briefly with your fingertip



Means pressing the left mouse button once

#### The actions initiated by tapping include

- ■ Selection of menus, features, or parameters
- Entering characters with the screen keyboard
- Closing dialogs

---

#### Double-tap

---



Means touching the screen twice briefly with your finger tip



Means pressing the left mouse button twice

**Double tapping leads to the following actions, for example:**

- Magnifying or minimizing images in the **Single** function and the **Inspection** function.

**Holding (long press)**

Means touching the screen and holding your finger(s) on it for a few seconds



Means pressing the left mouse button once and holding it down

**The actions initiated by holding are**

- Activate multiple selection

**Dragging**

Is a combination of long press and then swipe, moving a finger over the touchscreen when at least the starting point of motion is defined



Means pressing the left mouse button once and holding it down while moving the mouse; at least the starting point of the motion is defined

**The actions initiated by dragging include**

- Scrolling through lists and texts

## 6.4 General operating elements and functions

The operating elements described below are available for configuring and operating the product via the touchscreen or input devices.

### Screen keyboard

The screen keyboard enables you to enter text into the input fields of the user interface. Depending on the input field, a numeric or alphanumeric screen keyboard is shown.

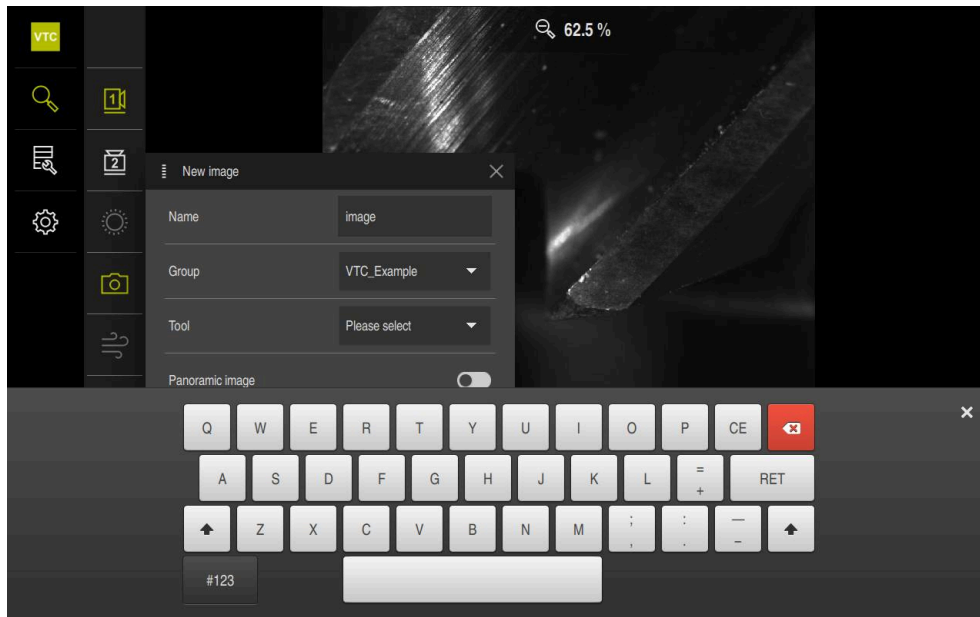



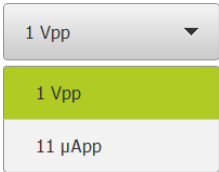





Figure 2: Screen keyboard

### Using the screen keyboard

- ▶ To enter values, tap an input field
- > The input field is highlighted.
- > The screen keyboard is displayed.
- ▶ Enter text or numbers
- > If the entry is correct and complete, a green check mark is displayed as applicable.
- > If the entry is incomplete or the values are incorrect, a red exclamation mark is displayed as applicable. In this case, the entry cannot be completed.
- ▶ To apply the values, confirm the entry with **RET**
- > The values are displayed
- > The screen keyboard disappears.

## Operating elements

Operating element	Function
	<p><b>Input fields with plus and minus buttons</b></p> <p>To adjust a numerical value, use the + (plus) and - (minus) buttons to the left and right of the numerical value.</p> <ul style="list-style-type: none"> <li>▶ Tap + or - until the desired value is displayed</li> <li>▶ Long-press + or - to scroll through the values more quickly</li> <li>&gt; The selected value is displayed.</li> </ul>
	<p><b>Toggle switch</b></p> <p>Use the toggle switch to switch between functions.</p> <ul style="list-style-type: none"> <li>▶ Tap the desired function</li> <li>&gt; The active function is shown in green.</li> <li>&gt; The inactive function is shown in light gray.</li> </ul>
	<p><b>Slide switch</b></p> <p>Use the slide switch to activate or deactivate a function.</p> <ul style="list-style-type: none"> <li>▶ Drag the slider to the desired position</li> <li>or</li> <li>▶ Tap the slide switch</li> <li>&gt; The function is activated or deactivated.</li> </ul>
	<p><b>Slider</b></p> <p>Use the slider (horizontal or vertical) to continuously adjust values.</p> <ul style="list-style-type: none"> <li>▶ Drag the slider to the desired position</li> <li>&gt; The selected value is displayed graphically or in percent.</li> </ul>
	<p><b>Drop-down list</b></p> <p>Buttons that open drop-down lists are indicated by a triangle pointing down.</p> <ul style="list-style-type: none"> <li>▶ Tap the button</li> <li>&gt; The drop-down list opens.</li> <li>&gt; The active entry is highlighted in green.</li> <li>▶ Tap the desired entry</li> <li>&gt; The selected entry is applied.</li> </ul>
Operating element	Function
	<p><b>Close</b></p> <ul style="list-style-type: none"> <li>▶ Tap <b>Close</b> to close a dialog</li> </ul>
	<p><b>Confirm</b></p> <ul style="list-style-type: none"> <li>▶ Tap <b>Confirm</b> to conclude an action</li> </ul>
	<p><b>Back</b></p> <ul style="list-style-type: none"> <li>▶ Tap <b>Back</b> to return to the higher level in the menu structure</li> </ul>

## 6.5 Manual tool inspection menu

### Activation



- ▶ Tap **Manual tool inspection** in the main menu
- > The user interface for the tool inspection is displayed.

### Short description

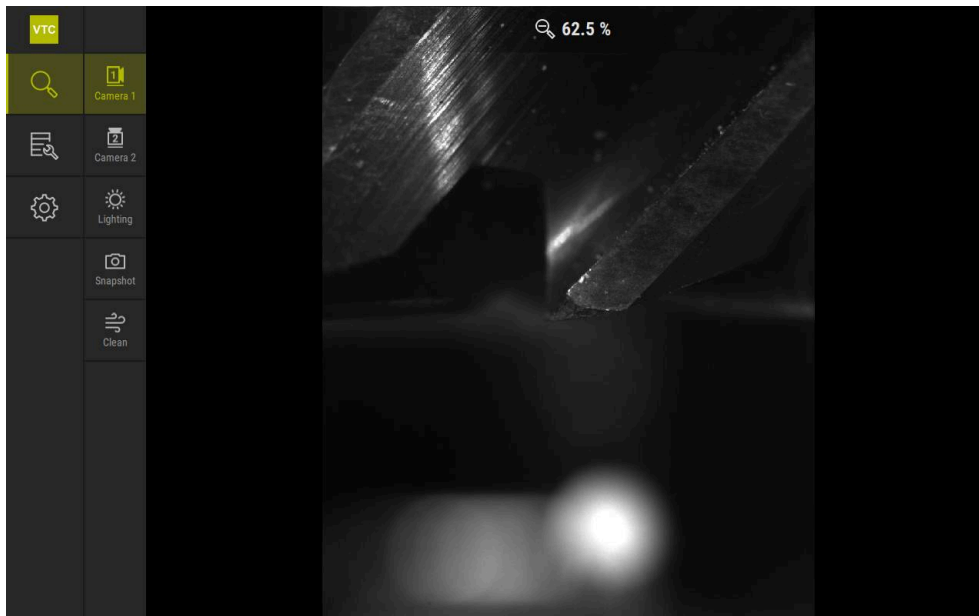







Figure 3: **Manual tool inspection** menu

### Functions

Operating element	Function
	<b>Camera 1</b> Usually shows the tool from the side
	<b>Camera 2</b> Usually shows the tool from below
	<b>Lighting palette</b> Setting the lighting with the LEDs on the device
	<b>New image</b> Taking a single shot or panoramic image
	<b>Blow off</b> Activation of the product's jet blocks for cleaning the cover glasses and the tool with compressed air

## 6.6 Tool evaluation menu

### Activation



- ▶ Tap **Tool evaluation** in the main menu
- The user interface for the evaluation of the tool condition is displayed.

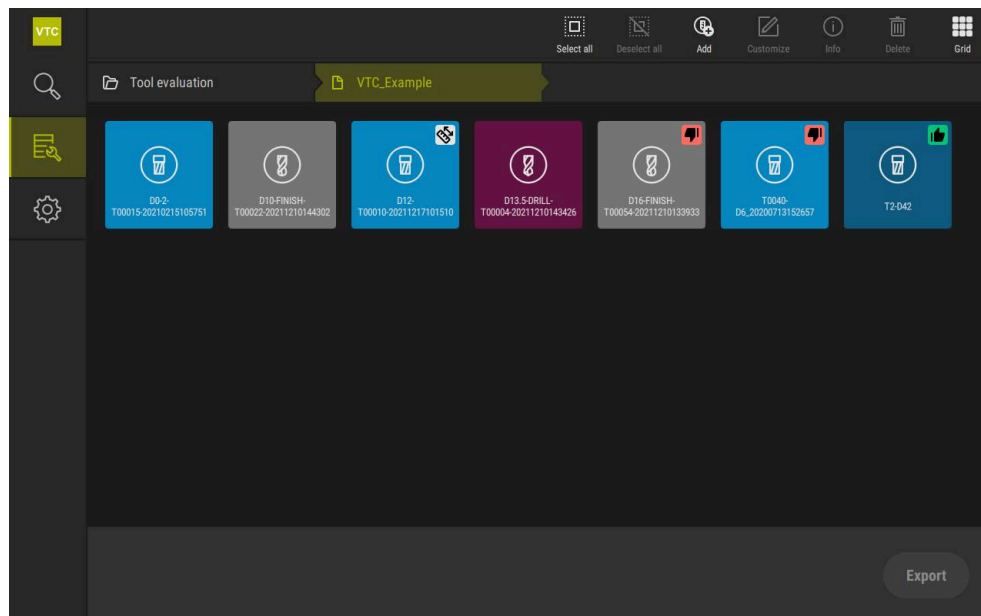

Figure 4: **Tool evaluation** menu

### Navigation elements

The **Tool evaluation** menu provides the following hierarchical menu levels: The navigation path in the function area helps you to orient yourself within the menu levels.

**Tool evaluation** ▶ **Group** ▶ **Tool** ▶ **Image series**

## 6.7 Settings menu

### Call



- ▶ Tap **Settings** in the main menu
- > The user interface for the product settings is displayed.

### Short description

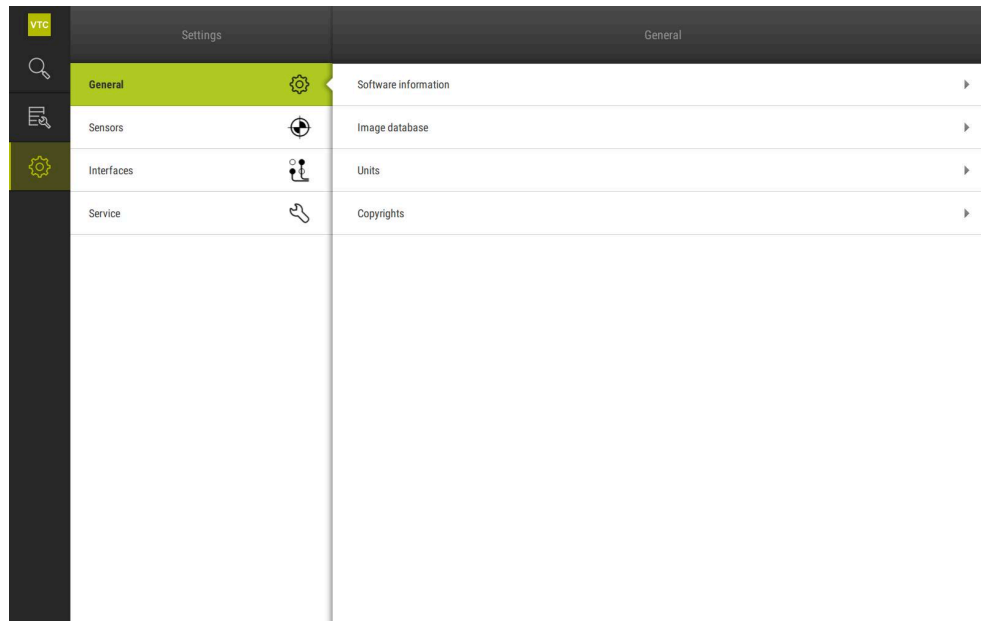

Figure 5: **Settings** menu

The **Settings** menu shows all of the options for configuring the product. The settings parameters allow you to adapt the product to on-site requirements.



# 7

## Manual Tool Inspection

## 7.1 Overview

In the **Manual tool inspection** menu, you can view the live image of a camera. You can also configure the lighting and save an image. The live image can be called via Cycle **621** at the connected control.

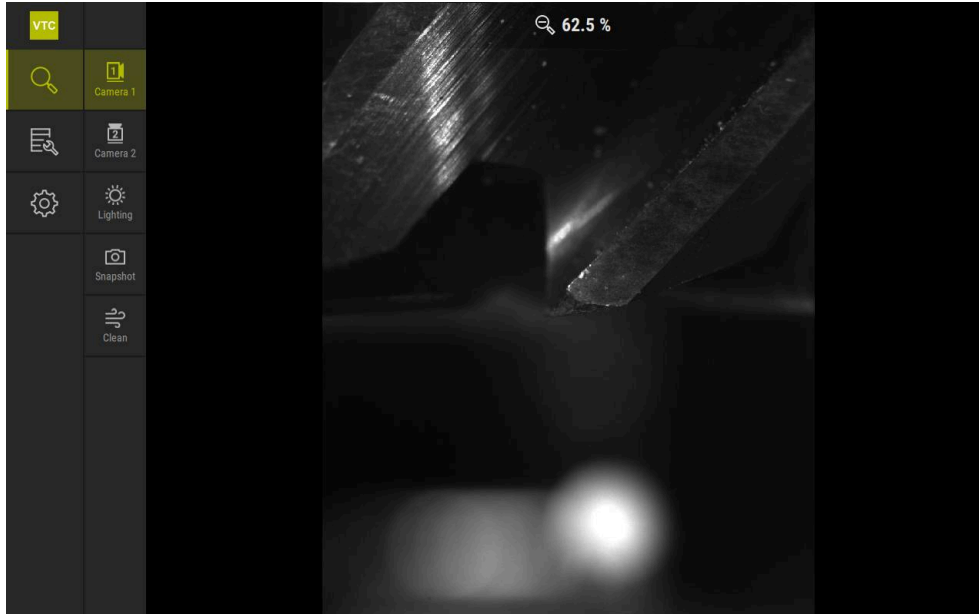

Figure 6: **Manual tool inspection** menu

## 7.2 Displaying a camera image

Camera 1 shows the side view of the tool. Camera 2 shows the tool view from below.

The camera views are activated via Cycle **621**.

To switch manually between the camera views of camera 1 and camera 2:



- ▶ Tap **Camera 1** to show the side view
- > The side view is displayed.
- > The active camera is displayed in green.



- ▶ Tap **Camera 2** to show the bottom view
- > The bottom view is displayed.
- > The active camera is displayed in green.

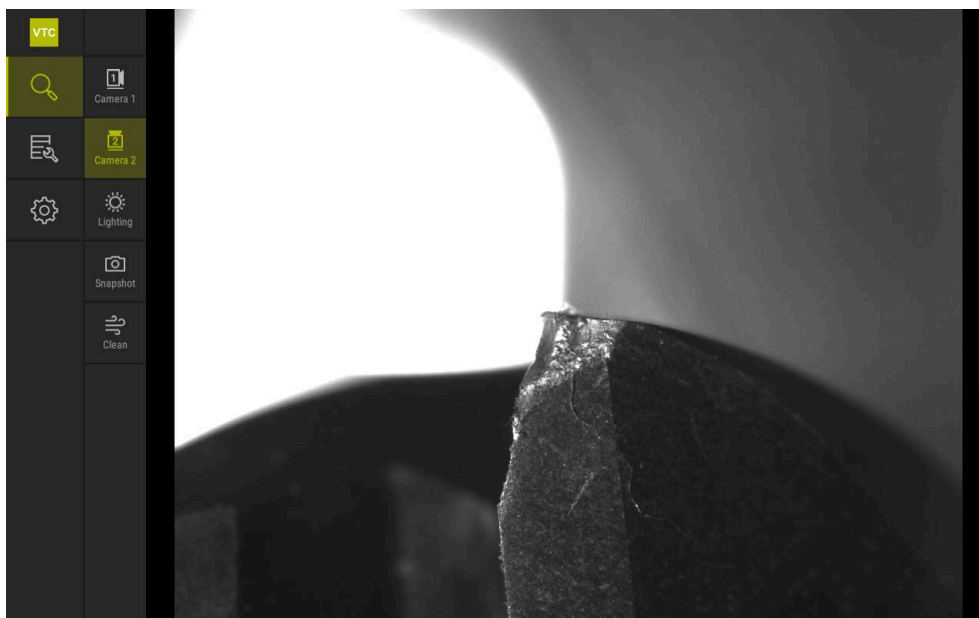

Figure 7: Live image of camera 2

## 7.3 Lighting palette

You can individually adapt the brightness of the LEDs on the device depending on the light conditions inside the machine tool. Camera 1 and camera 2 each have a ring light with twelve LEDs for this purpose.

Under **Simple** in the lighting palette, you can set the brightness of the individual sectors. Under **Extended**, you can control each LED in the ring light separately.

### 7.3.1 Opening the lighting palette



- ▶ Tap **Lighting** in the **Manual tool inspection** menu
- ▶ The **Simple** lighting palette is opened.
- ▶ Tap **Extended** to control each LED separately
- ▶ The **Extended** lighting palette is opened.

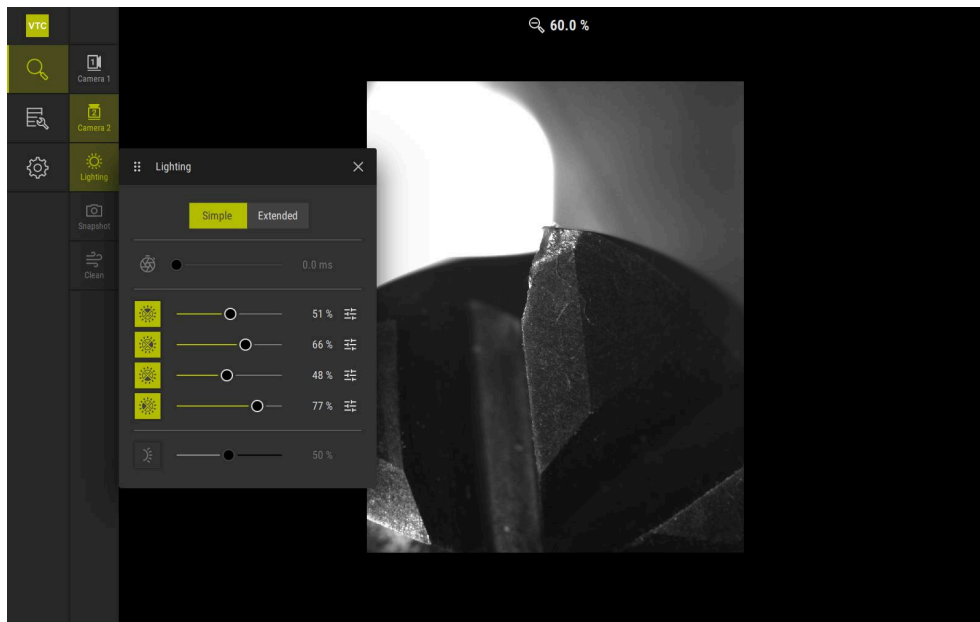









Figure 8: **Lighting** dialog box

### 7.3.2 Operating elements of the Lighting palette

The following functions are available in the lighting palette:

Symbol	Explanation
	<p><b>Simple:</b> Exposure time with an accuracy of 1/10 ms</p> <p><b>Extended:</b> Exposure time with an accuracy of 1/100 ms</p> <ul style="list-style-type: none"> <li>Settings: <b>0 ms...66 ms</b></li> <li>Default setting: <b>7 ms</b></li> </ul> <div style="border: 1px solid black; padding: 5px; margin-top: 10px;">  The settings options vary depending on the connected vision system.         </div>
	<p><b>Simple:</b> Average brightness of the upper sector</p> <p><b>Extended:</b> Brightness of the upper three LEDs. The LEDs can be controlled separately.</p> <ul style="list-style-type: none"> <li>Settings: <b>0%...100%</b></li> <li>Default setting: <b>50%</b></li> </ul>
	<p><b>Simple:</b> Average brightness of the right-hand sector</p> <p><b>Extended:</b> Brightness of the upper three LEDs. The LEDs can be controlled separately.</p> <ul style="list-style-type: none"> <li>Settings: <b>0 % ... 100 %</b></li> <li>Default setting: <b>50 %</b></li> </ul>
	<p><b>Simple:</b> Average brightness of the lower sector</p> <p><b>Extended:</b> Brightness of the lower three LEDs. The LEDs can be controlled separately.</p> <ul style="list-style-type: none"> <li>Settings: <b>0 % ... 100 %</b></li> <li>Default setting: <b>50 %</b></li> </ul>
	<p><b>Simple:</b> Average brightness of the left-hand sector</p> <p><b>Extended:</b> Brightness of the three left-hand LEDs. The LEDs can be controlled separately.</p> <ul style="list-style-type: none"> <li>Settings: <b>0 % ... 100 %</b></li> <li>Default setting: <b>50 %</b></li> </ul>
	<p>The operating element is displayed in simple mode if three bundled LEDs have different lighting values.</p>
	<p>Brightness of the lateral LED on the jet block</p> <ul style="list-style-type: none"> <li>Settings: <b>0 % ... 100 %</b></li> <li>Default setting: <b>50 %</b></li> </ul>

### 7.3.3 Configuring the lighting

The lighting palette provides sliders for stepless adjustment of the lighting:

- In **Simple** mode, the sliders show the average value of the three LEDs in percent.
- In **Extended** mode, the sliders show the individual values of the LEDs in percent.

The percentage value shows the brightness setting of the LEDs for the respective camera. If the value is below 100 %, the LEDs are dimmed.

 If you want an LED to remain switched off during automatic recording, set the value to 0 %.

To adjust the lighting:

#### Configuring the lighting in simple mode



- ▶ Select the desired camera

- ▶ Tap **Lighting**



- ▶ To set the brightness of individual sectors, tap **Simple**

- ▶ To activate the sensor, tap the corresponding operating element

- > The operating element and the slider are displayed in green.

- ▶ To set the desired lighting, drag the slider horizontally to the right or left

- > The lighting is adjusted.

#### Configuring the lighting in extended mode



- ▶ Select the desired camera

- ▶ Tap **Lighting**



- ▶ To set the brightness of individual LEDs, tap **Extended**

- ▶ To activate the sensor, tap the corresponding operating element

- > The operating element and the slider are displayed in green.

- ▶ To set the desired lighting, drag the slider horizontally to the right or left

- > The lighting is adjusted.

 The lighting that was configured in one mode is automatically transferred to the other lighting mode.

#### Closing the lighting palette



- ▶ Tap **Close** to close the dialog  
or



- ▶ Tap **Lighting**

- > The lighting configuration is saved.

- > The dialog is closed.

## 7.4 Manual single shots

You can manually take shots of a live image and save them. Based on the images, you can check the tool for breakage.

**i** If you create and open a group and a tool entry in the **Tool evaluation** menu beforehand, this information is automatically transferred when a new image is taken.

**Further information:** "Adding a new group", Page 90

**Further information:** "Adding a new tool entry", Page 93

### 7.4.1 Taking a manual single shot



- ▶ Tap **Record** in the Manual tool inspection menu
- The **New image** dialog box appears.
- ▶ Enter the desired parameters (see "Parameters of the single shot", Page 84)
- ▶ Tap **OK** to save the single shot
- The single shot is saved in the specified **Tool evaluation** area.

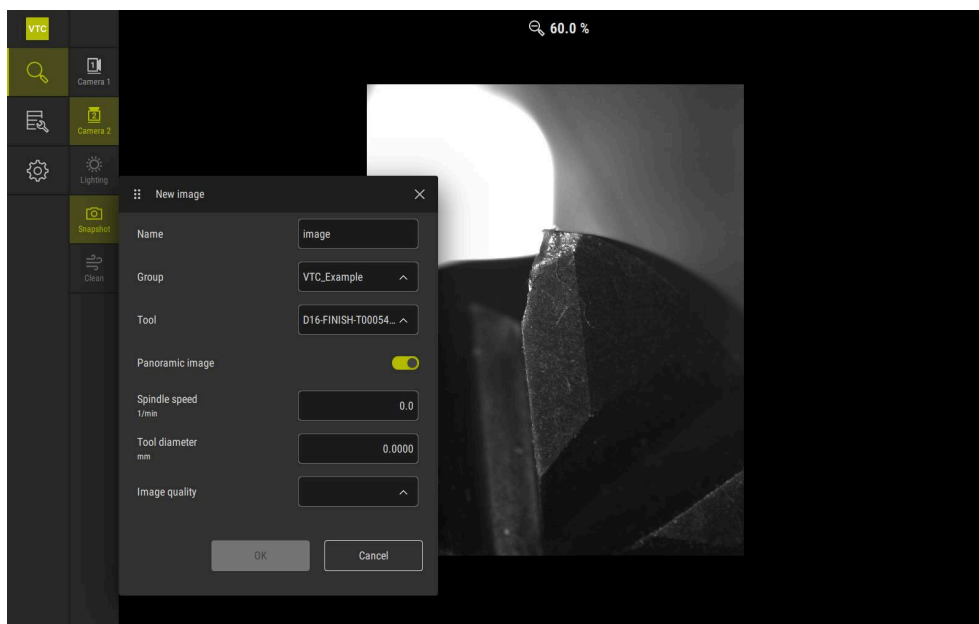

Figure 9: **New image** dialog box

## 7.4.2 Parameters of the single shot

The following parameters are available in the **New image** dialog:

Parameter	Explanation
<b>Name</b>	Name of the image under which it is saved in the <b>Tool evaluation</b>
<b>Group</b>	Assignment to a group in the <b>Tool evaluation</b>
<b>Tool</b>	Assignment to a tool entry in the <b>Tool evaluation</b>
<b>Panoramic image</b>	Activation of panoramic image <ul style="list-style-type: none"> <li>■ Setting: ON or OFF</li> <li>■ Default setting: OFF</li> </ul>
<b>Spindle speed</b>	Entry of the tool rotation value. The camera needs this information to generate a panoramic image <ul style="list-style-type: none"> <li>■ Setting: <b>Corresponding spindle speed of the machine tool</b></li> <li>■ Default setting: <b>0.0 rpm</b></li> </ul>
<b>Tool diameter</b>	Entry of the diameter of the respective tool. The application needs this information to generate a panoramic image <ul style="list-style-type: none"> <li>■ Setting: <b>Diameter of the tool in the machine</b></li> <li>■ Default setting: <b>0.0000 mm</b></li> </ul>
<b>Image quality</b>	Selection of the quality in which the image is to be saved <ul style="list-style-type: none"> <li>■ Setting: <b>Fast, Medium</b> or <b>High</b></li> <li>■ Default setting: /</li> </ul>



A higher quality requires a lower spindle speed.

## 7.5 Cleaning

The **Reinigen** button allows you to clean the cover glasses and the area around the tool with compressed air.



- ▶ Tap **Reinigen** in the Manual tool inspection menu
- ▶ The **Blow off** dialog box appears.
- ▶ Tap and hold **Start** in the **Blow off** dialog box
- ▶ The cover glasses and the tool are cleaned with compressed air from the product's jet blocks.
- ▶ Release **Start**
- ▶ The compressed air is switched off.

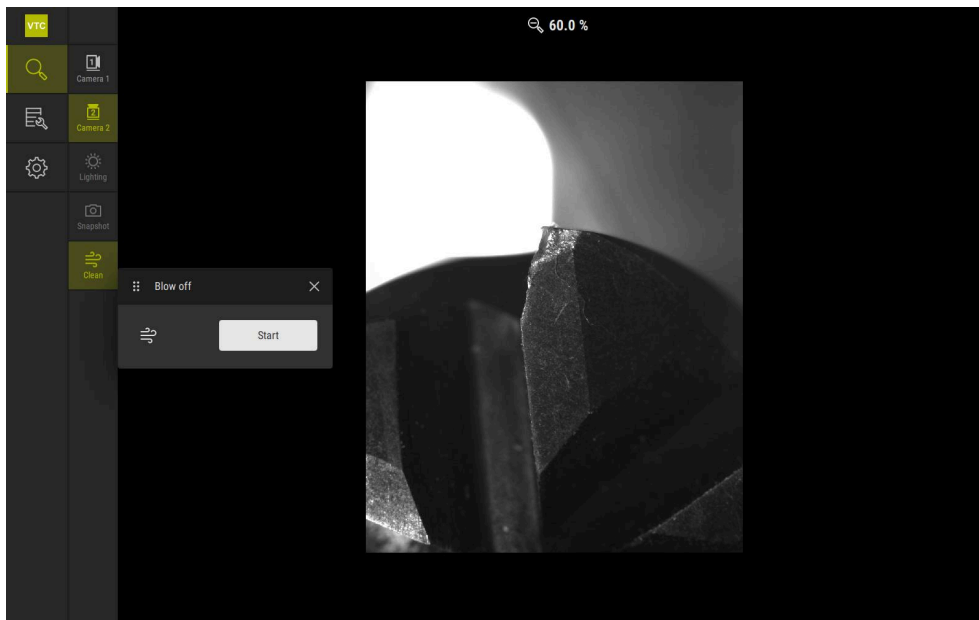

Figure 10: **Blow off** dialog box



# 8

## Tool Evaluation

## 8.1 Overview

The **Tool evaluation** menu gives you access to the images from the Cycles **621** and **622**.

To get an overview of the images taken, you can combine images and image series in groups that you organize as needed. For the actual evaluation, the images can then be analyzed in various modes and compared with each other.

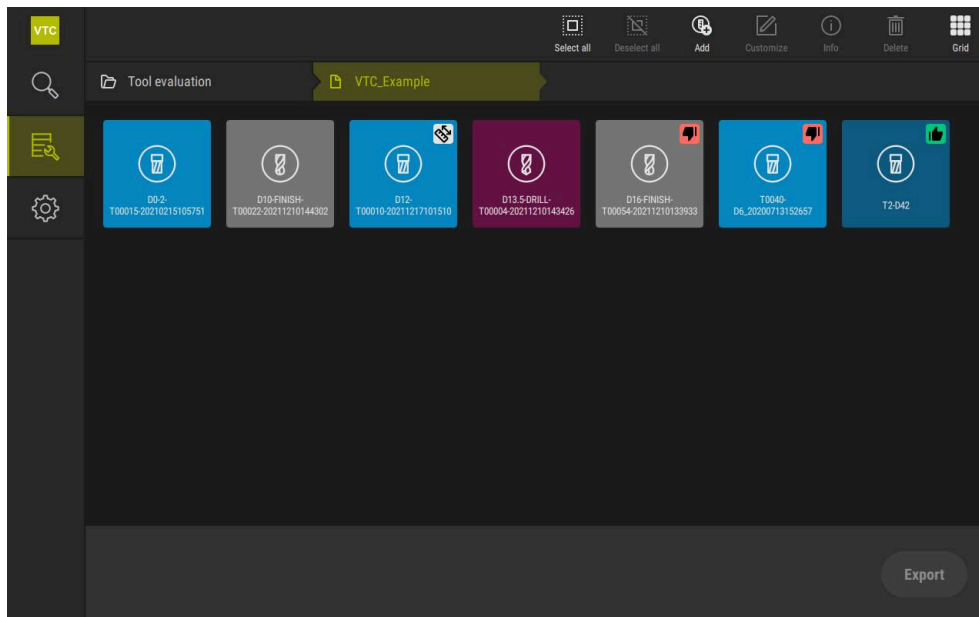

Figure 11: **Tool evaluation** menu

## 8.2 Navigating within the tool evaluation



### Menu levels

The **Tool evaluation** menu has the following menu levels:

- **Tool evaluation** menu level
- **Group** menu level
- **Tools** menu level

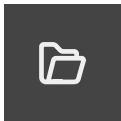

### Navigation path

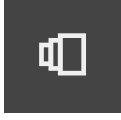
The navigation path in the function area of the **Tool evaluation** menu enables you to navigate within the menu levels.

Icon	Menu level
	<b>Tool evaluation</b>
	<b>Group</b>
	<b>Tools</b>
	<b>Image series</b>

 If you display a previously selected menu level again via the navigation path, your last selection in the menu level will be shown with a green marking.

### Display options

Operating element	Explanation
	<b>View small</b> Elements are displayed in small size
	<b>View medium</b> The elements are displayed in medium size
	<b>View large</b> Elements are displayed in large size

## 8.3 Tool evaluation menu level

In the **Tool evaluation** menu level, you can define groups. The groups allow you to structure the tool entries, single shots, and image series.









You will also indicate the group as **QS610** parameter when generating image series in Cycle **622**.

**Further information:** "Cycle parameters", Page 34

### 8.3.1 Operating elements of the Tool evaluation menu level

The **Tool evaluation** menu level provides the following functions:

Operating elements	Explanation
	<p><b>Select all</b></p> <p>Selects all displayed elements of the level.</p>
	<p><b>Deselect all</b></p> <p>Deactivates the selection of all displayed elements of the level.</p>
	<p><b>Add</b></p> <p>Creates a new group and opens the <b>Add group</b> dialog box.</p>
	<p><b>Customize</b></p> <p>Opens the <b>Customize</b> dialog box. The group can be renamed and customized with the following elements:</p> <ul style="list-style-type: none"> <li>■ <b>Icon</b></li> <li>■ <b>Color</b></li> <li>■ <b>Comment</b></li> </ul>
	<p><b>Info</b></p> <p>Activates the display of the following information on the selected element:</p> <ul style="list-style-type: none"> <li>■ Creation date</li> <li>■ Change date</li> <li>■ Last opened on</li> <li>■ <b>Comment</b></li> </ul>
	<p><b>Delete</b></p> <p>Opens the <b>Delete</b> dialog box.</p>

### 8.3.2 Adding a new group



- ▶ To create a new group, tap **Add**
- > The **Add group** dialog box appears.
- ▶ Tap the **Name** field
- ▶ Enter the desired name via the screen keyboard
- ▶ Confirm with **RET**
- ▶ Confirm with **OK**
- > The new group is created.

### 8.3.3 Renaming and customizing the group

- ▶ To edit a group, tap and hold the group in question
- > The group is shown highlighted.



- ▶ Tap **Customize**
- > The **Customize** dialog box appears.
- ▶ Tap the **Name** field and enter a new name as needed
- ▶ Confirm with **RET**
- ▶ Tap the desired icon as needed
- ▶ Tap the desired color, if applicable
- ▶ Tap the **Comment** field and enter a comment, if required
- ▶ Confirm with **RET**
- ▶ Confirm with **OK**
- > The representation of the group is changed accordingly.

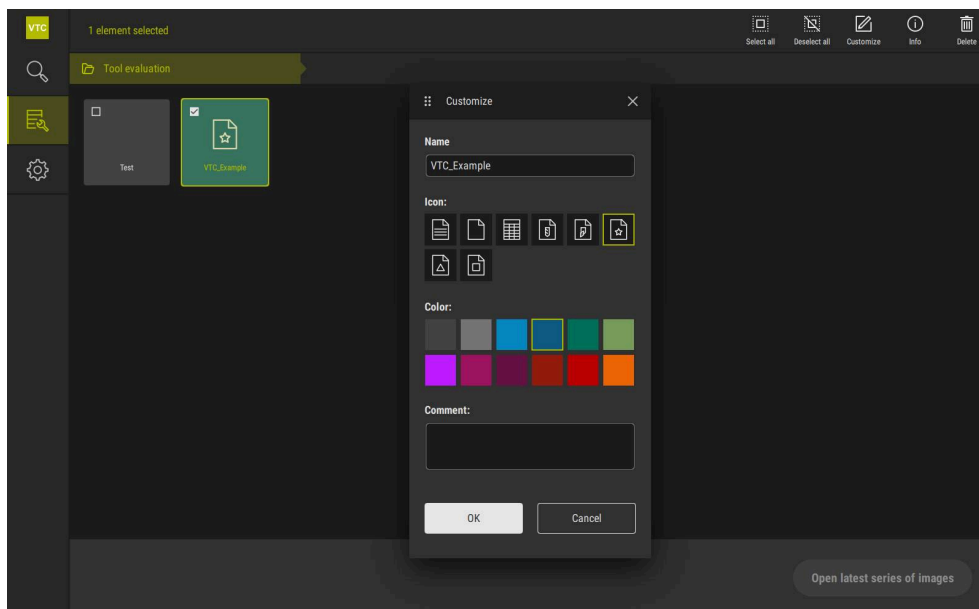

Figure 12: **Customize** dialog box

### 8.3.4 Delete group



Please note that deleting a group also deletes all of the tool entries and their contents in the group.

- ▶ To edit a group, tap and hold the group in question
- > The group is shown highlighted.



- ▶ Tap **Delete**
- > The **Delete** dialog box appears.
- ▶ To delete the group and all of the tool entries in the group, confirm with **OK**
- > The group is removed.

## 8.4 Group menu level

In the **Group** menu level, you can create tool entries. The tool entries allow you to structure the images individually.

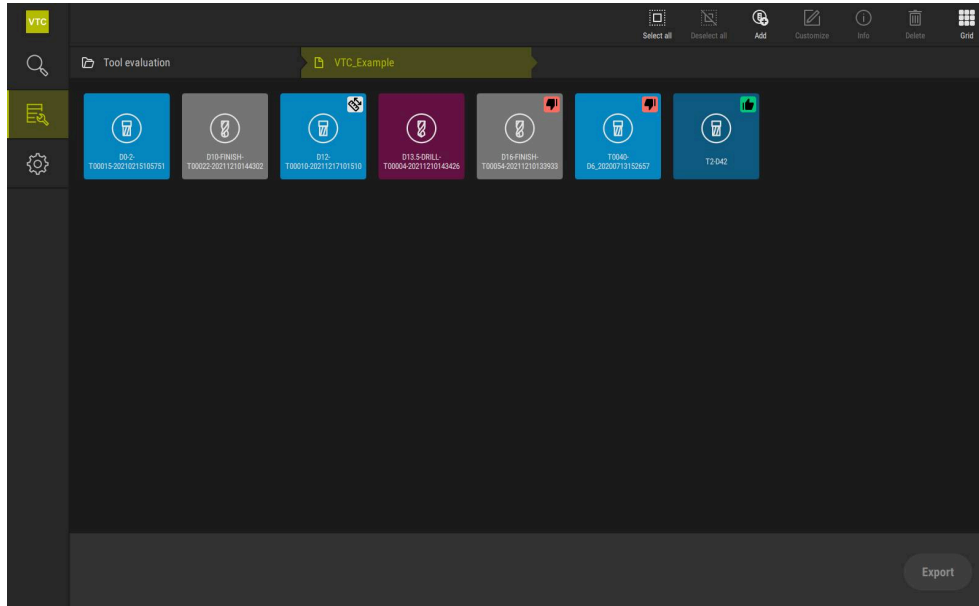







Figure 13: **Group** menu level

### 8.4.1 Operating elements of the Group menu level

The **Group** menu level provides the following functions:

Operating elements	Explanation
	<p><b>Select all</b></p> <p>Selects all displayed elements of the level.</p>
	<p><b>Deselect all</b></p> <p>Deactivates the selection of all displayed elements of the level.</p>
	<p><b>Add</b></p> <p>Creates a new tool entry and opens the <b>Add tool entry</b> dialog box.</p>
	<p><b>Customize</b></p> <p>Opens the <b>Customize</b> dialog box. The tool entry can be renamed and customized with the following elements:</p> <ul style="list-style-type: none"> <li>■ <b>Icon</b> (various tool types)</li> <li>■ <b>Color</b></li> <li>■ <b>Comment</b></li> </ul>
	<p><b>Info</b></p> <p>Activates the display of the following information on the selected element:</p> <ul style="list-style-type: none"> <li>■ Creation date</li> <li>■ Change date</li> <li>■ Last opened on</li> <li>■ <b>Status</b></li> <li>■ <b>Status last applied</b></li> <li>■ <b>Comment</b></li> </ul>
	<p><b>Delete</b></p> <p>Opens the <b>Delete</b> dialog box.</p>

### 8.4.2 Adding a new tool entry



- ▶ To create a new tool entry, tap **Add**
- > The **Add tool entry** dialog box appears.
- ▶ Tap the **Name** field
- ▶ Enter the desired name via the screen keyboard
- ▶ Confirm with **RET**
- ▶ Confirm with **OK**
- > A new tool entry is created.

### 8.4.3 Renaming and customizing the tool entry

- ▶ To edit a tool entry, tap and hold the desired tool entry
- > The tool entry is shown highlighted.



- ▶ Tap **Customize**
- > The **Customize** dialog box appears.
- ▶ Tap the **Name** field and enter a new name as needed
- ▶ Confirm with **RET**
- ▶ Tap a tool-type icon as desired
- ▶ Tap the desired color, if applicable
- ▶ Tap the **Comment** field and enter a comment, if required
- ▶ Confirm with **RET**
- ▶ Confirm with **OK**
- > The representation of the tool entry is changed accordingly.

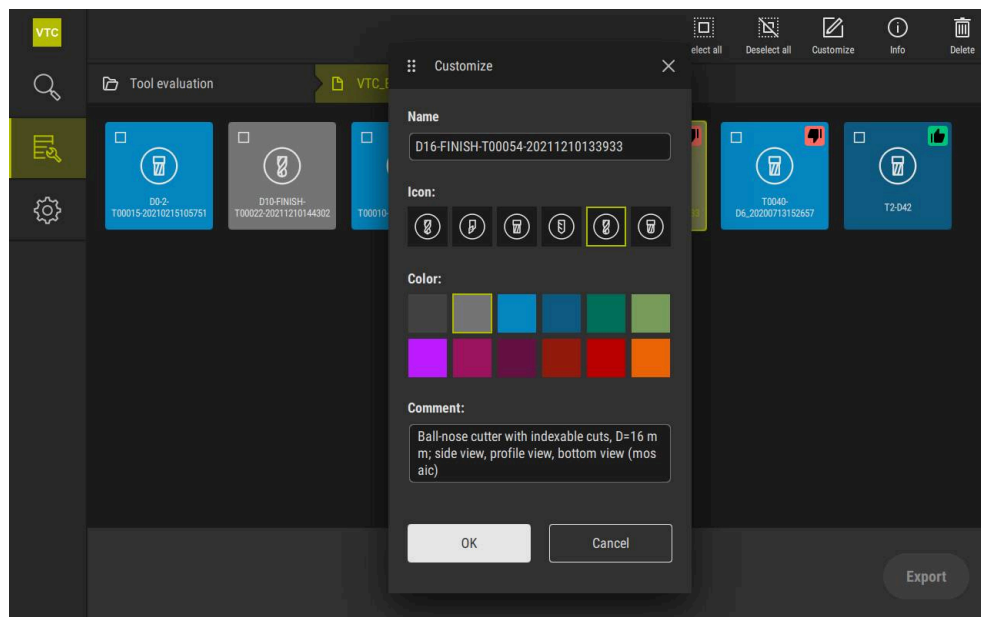

Figure 14: **Customize** dialog box

### 8.4.4 Delete tool entry



Please note that deleting a tool entry also deletes all images and image series of the tool entry.

- ▶ To edit a tool entry, tap and hold the desired tool entry
- > The tool entry is shown highlighted.



- ▶ Tap **Delete**
- > The **Delete** dialog box appears.
- ▶ To delete the tool entry and the images in it, confirm with **OK**
- > The tool entry is removed.

## 8.5 Tools menu level

In the **Tools** menu level, you can display the images of a tool and change the tool status. To combine a series of several images, you can also create image series. You can either create the images yourself in the **Manual tool inspection** menu or have them generated by Cycle **622**.

Tap **Quick-start of tool checking** to start with the first image series.

**Further information:** "Taking a manual single shot", Page 83

**Further information:** "Cycle parameters", Page 34

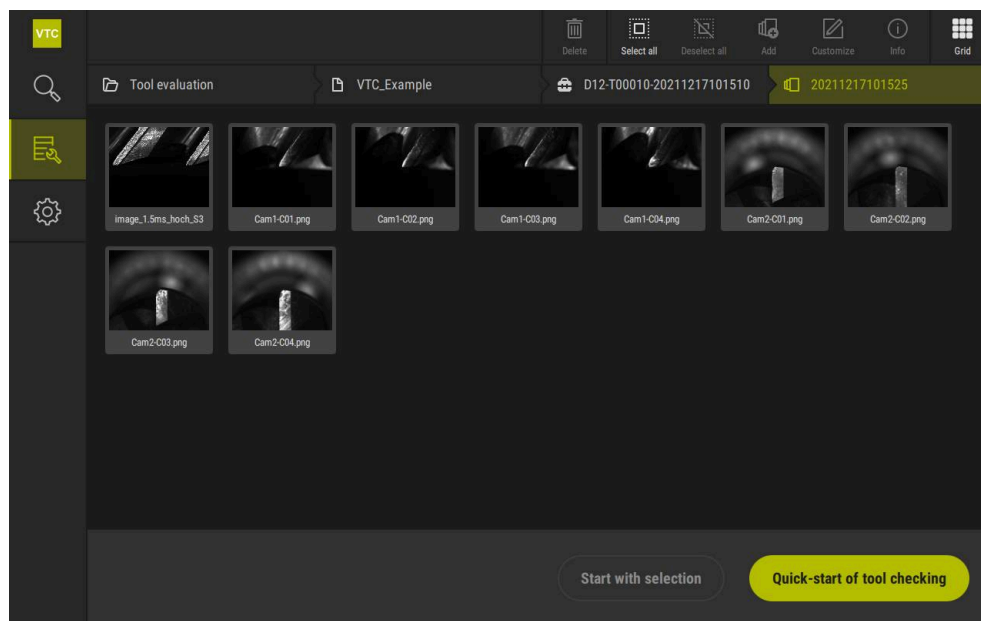







Figure 15: **Tools** menu level

### 8.5.1 Operating elements of the Tools menu level

The **Tools** menu level provides the following functions:

Operating element	Explanation
	<p><b>Select all</b></p> <p>Selects all displayed elements of the level.</p>
	<p><b>Deselect all</b></p> <p>Deactivates the selection of all displayed elements of the level.</p>
	<p><b>Add</b></p> <p>Creates a new image series and opens the <b>Add image series</b> dialog box.</p>
	<p><b>Customize</b></p> <p>Opens the <b>Customize</b> dialog box. The image series can be renamed and customized with the following elements:</p> <ul style="list-style-type: none"> <li>■ <b>Color</b></li> <li>■ <b>Comment</b></li> </ul>
	<p><b>Info</b></p> <p>Activates the display of the following information on the selected element:</p> <ul style="list-style-type: none"> <li>■ Creation date</li> <li>■ Change date</li> <li>■ Last opened on</li> <li>■ Optional: <ul style="list-style-type: none"> <li>■ Image size</li> <li>■ View</li> <li>■ Camera</li> <li>■ Lighting information</li> <li>■ Exposure time</li> </ul> </li> <li>■ <b>Comment</b></li> </ul>
	<p><b>Delete</b></p> <p>Opens the <b>Delete</b> dialog box.</p>

### 8.5.2 Adding a new image series



- ▶ To create a new image series, tap **Add**
- > The **Add image series** dialog box appears.
- ▶ Tap the **Name** field
- ▶ Enter the desired name via the screen keyboard
- ▶ Confirm with **RET**
- ▶ Confirm with **OK**
- > A new image series is created.

### 8.5.3 Renaming and customizing the image series

- ▶ To edit an image series, tap and hold the image series in question
- The image series is shown highlighted.



- ▶ Tap **Customize**
- The **Customize** dialog box appears.
- ▶ Tap the **Name** field and enter a new name as needed
- ▶ Confirm with **RET**
- ▶ Tap the desired color, if applicable
- ▶ Tap the **Comment** field and enter a comment, if required
- ▶ Confirm with **RET**
- ▶ Confirm with **OK**
- The representation of the image series is adjusted.

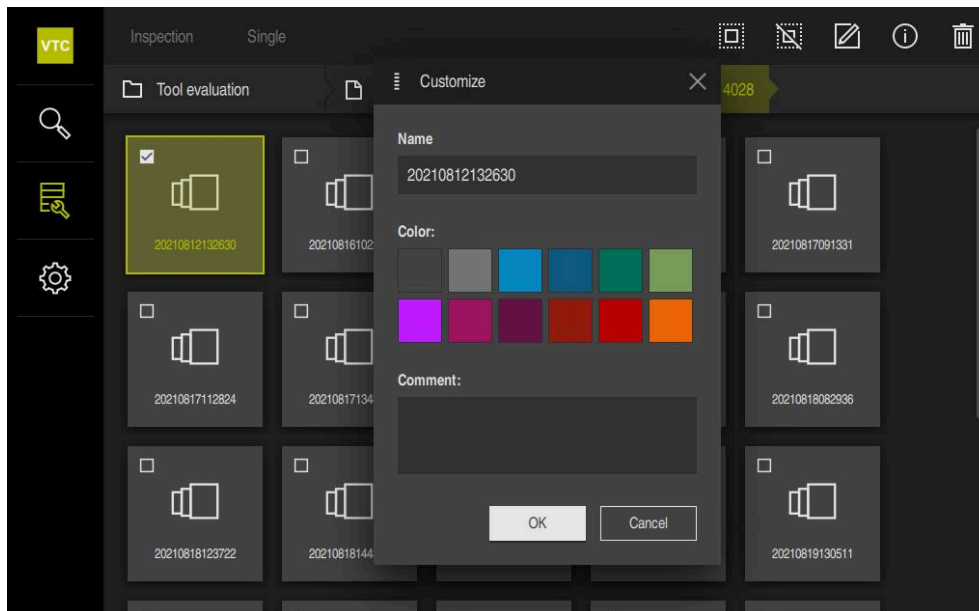

Figure 16: **Customize** dialog box

## 8.5.4 Deleting the image series and individual images



Please note that deleting an image series deletes all of the images that belong to this series.

- ▶ To edit an image series, tap and hold the image series in question
- > The image series is shown highlighted.



- ▶ Tap **Delete**
- > The **Delete** dialog box appears.
- ▶ To delete the image series and the images in it, confirm with **OK**
- > The image series is removed.



- ▶ To delete a single shot, tap the desired single shot
- ▶ Tap **Delete**
- > The single shot is removed.

## 8.6 Tool analysis

The tool analysis allows you to

- Examine and measure the wear status of your tools
- Examine the progress of the tool condition in different ways
- Create reports with the measured wear values

The tool analysis allows you to examine and measure the wear status of your tools, examine the progress of the tool condition in different ways and to create reports with the measured wear values.

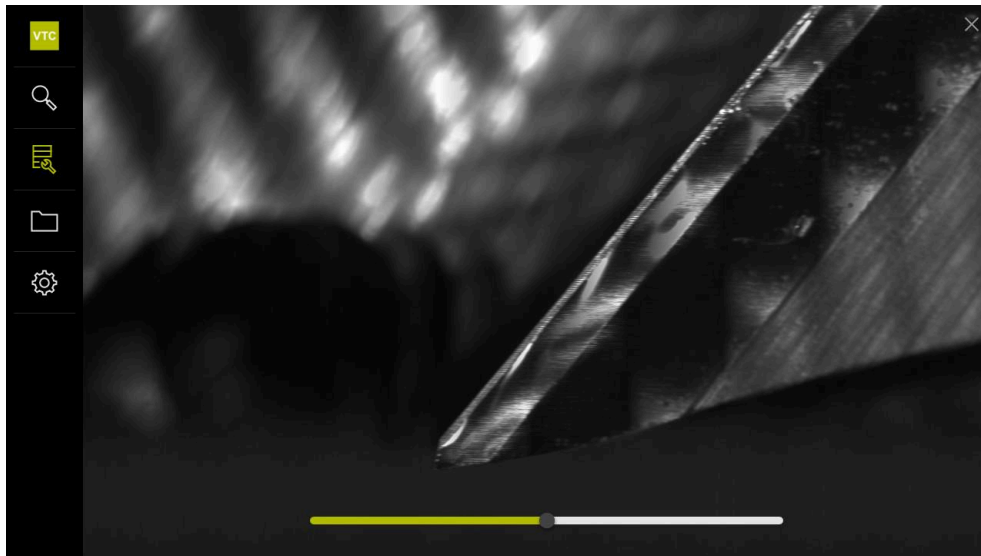



Figure 17: Tool analysis

Operating element	Explanation
	<b>Gallery</b> Shows all images of the tool in the gallery view.
	<b>Close</b> Closes the tool analysis window.

### 8.6.1 Working in Image viewer mode

The **Image viewer** mode is available for images from the cycles and for images from the manual tool inspection. The **Image viewer** mode allows you to magnify parts of the image and to navigate between the images.

If the image is a panoramic image, you can improve wear control by virtually adapting the displayed illumination angle of individual cutting edges via the slider in order to illuminate the tool optimally and to remove any reflections.

To work with the **Image viewer** mode:

- ▶ Tap the desired image
- > **Image viewer** opens.



- ▶ To view the individual images of a tool, tap **Single**
- > The single view opens.



- ▶ To view the tool in the panoramic view, tap **Panorama**
- > The panoramic view is shown.



- ▶ To adjust the brightness and contrast of the image, tap **Optimize**
- > The image view is adjusted.



- ▶ To magnify an image, tap **Magnify**
- > Gradually magnifies the image.
- > The image size is shown in percent.



- ▶ To minimize an image, tap **Shrink**
- > Gradually reduces the image.
- > The image size is shown in percent.

- ▶ To switch between the 100% view and the full-surface view in the window, double-tap the image

**Virtually removing reflections in the panoramic image**

- ▶ To illuminate the tool optimally without any reflections, drag the slider for the illumination angle to the right or left
- > The incidence angle of the light is adjusted.
- > The representation of the cutting edge is optimally illuminated in the virtual image to remove any reflections.

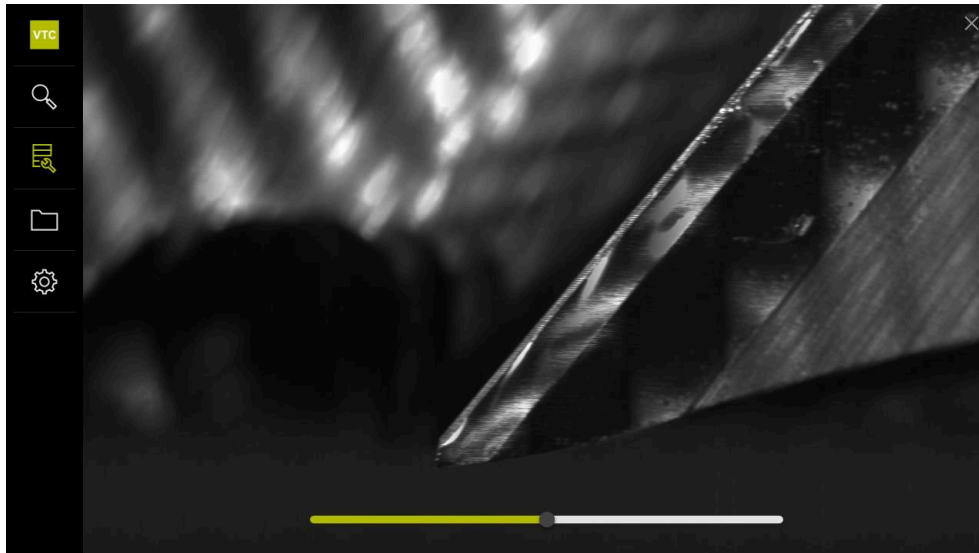

Figure 18: Illumination angle of the panoramic image

**Depiction of small tools in the panoramic image**

For small tools with a diameter  $< 4$  mm, the depiction of the cutting edges is adjusted and the lateral image margins are shown semitransparent.

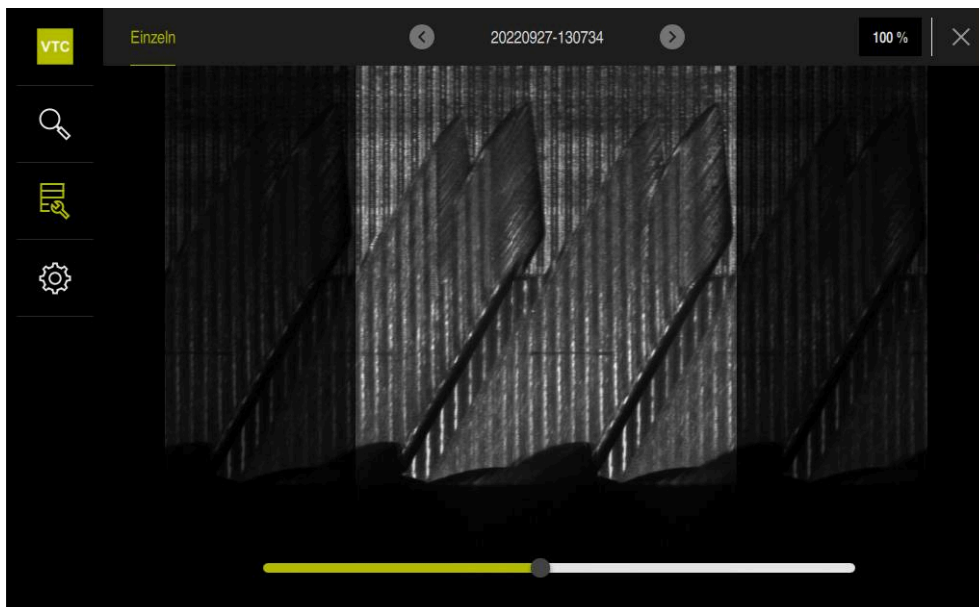

Figure 19: Panoramic image of small tools

## 8.6.2 Working in Inspection mode

**i** The **Inspection** mode is only available for automatically generated image series from Cycle **622**.

The following image views are available in the **Inspection** mode:

- **Bottom view**
- **Side view**
- **Profile view** (only for ball-nose cutters or toroid cutters)

The **Side view** and **Bottom view** provide a single view or, possibly, a panoramic view.

If you select a **Side view** or **Bottom view**, an image detail will be shown in the **Zoom view**.

The zooming frame can be used in the **Side view** and the **Bottom view**.

- If you change the image position in the **Zoom view**, the zooming frame will show you the current position in the **Side view** or **Bottom view**.
- The **Zoom view** allows you to magnify or minimize the image detail. The zooming frame adapts according to the image detail.
- If you set a zooming frame and switch between the images within a series, the set zooming frame remains at the same position.

If you have current images of a cycle, you can inspect your tool based on the images and define the corresponding **Tool status**.

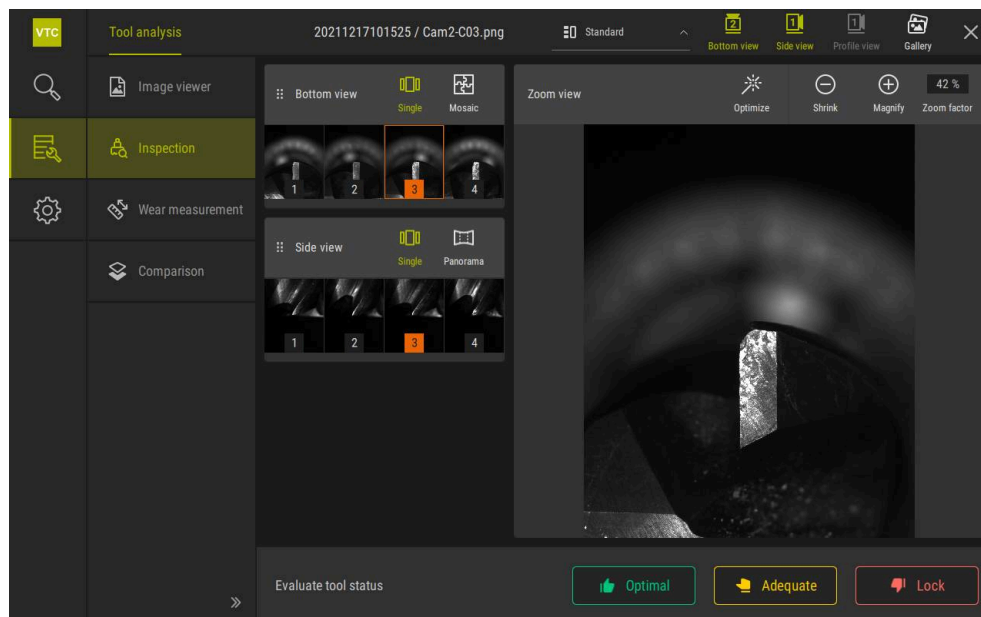













Figure 20: **Inspection** mode

### Operating elements of the Inspection mode

The following operating elements are available in the **Inspection** mode:

Operating element	Function
<b>Tool status</b>	<p>Defines the tool status; the following options are available:</p> <ul style="list-style-type: none"> <li>■ <b>Optimal</b> (green)</li> <li>■ <b>Adequate</b> (yellow)</li> <li>■ <b>Lock</b> (red)</li> </ul>
	<p>Activates and deactivates the <b>Bottom view</b>. The <b>Bottom view</b> shows the selected tool image from the perspective of camera 2.</p>
	<p>Activates and deactivates the <b>Side view</b>. The <b>Side view</b> shows the selected tool image from the perspective of camera 1.</p>
	<p>Activates and deactivates the <b>Profile view</b>. The <b>Profile view</b> shows the image of the complete profile of a cutting edge from the perspective of camera 1. This view is only available for ball-nose cutters or toroid cutters.</p>
	<p>Activates and deactivates the <b>Gallery</b>.</p>
	<p>Activates and deactivates the <b>Single</b> images of a series. This view is available in the <b>Bottom view</b> and the <b>Side view</b>.</p>
	<p>Activates and deactivates the <b>Mosaic</b> view. The <b>Mosaic</b> view shows an existing mosaic image or generates a composed image from the single images of a tool from below (camera 2). This view is only available in the <b>Bottom view</b>.</p>
	<p>Activates and deactivates the <b>Panoramic view</b> if a panoramic image was taken within the series (camera 1). This view is only available in the <b>Side view</b>.</p>
	<p><b>Optimize</b> Adjusts the brightness and contrast of the image</p>
	<p><b>Magnify / Shrink</b> Gradually magnifies or minimizes the image detail</p>
	
	

To use the views and the zooming frame in the **Inspection** mode:

- ▶ Tap an image in the **Bottom view** or **Side view**
- > An orange frame is placed around the selected image.
- > The zooming frame shows the image detail in **Zoom view**.
- ▶ To change the image detail, tap the **Zoom view** and drag it to the desired position
- > The zooming frame shows the new position in the selected image.



- ▶ To adjust the brightness and contrast of the image, tap **Optimize**
- > The image view is adjusted.



- ▶ To magnify an image, tap **Magnify**
- > Gradually magnifies the image.
- > The image size is shown in percent.



- ▶ To minimize an image, tap **Shrink**
- > Gradually reduces the image.
- > The image size is shown in percent.
  
- ▶ To switch between the 100% view and the full-surface view in the window, double-tap the image



- In the **Side view** and the **Bottom view**, numbers show the relations. This allows you to put the images of the cutting edges in relation to one another.
- Double-click the **Zoom view** to switch directly between the 100% view and the entire image.
- Press and hold the **Zoom view** to magnify the image detail in this area. After a short time, a zoom window appears that you can adjust by dragging.

### Evaluate tool status

In **Tool status**, you can evaluate the status of the tool based on the images from the currently active cycle.

- ▶ Depending on the result of your evaluation, select a status:
  - **Optimal** (green)
  - **Adequate** (yellow)
  - **Lock** (red)
- ▶ Tap **Confirm** in the dialog box
- > The tool status is saved with date and time.

- i** To cancel an evaluation
- ▶ Tap the selected status again
  - ▶ Tap **Confirm** in the dialog box
  - > The evaluation is canceled.

- i** Applicable only to HEIDENHAIN TNC7 and TNC 640 controls:  
If you select the **Lock** tool status, the tool will be locked permanently in the tool table **TOOL.T**.

### 8.6.3 Working in Wear measurement mode

- i** The **Wear measurement** mode is only available for automatically generated image series from Cycle **622**.

The following image views are available in **Wear measurement** mode:

- **Single**
- **Panorama**

In the images of a cycle you can measure the tool-flank wear and determine the corresponding **Tool status**.

The measured flank-wear data can be exported as a CSV file.

**Further information:** "Transferring wear values via an export file ", Page 108

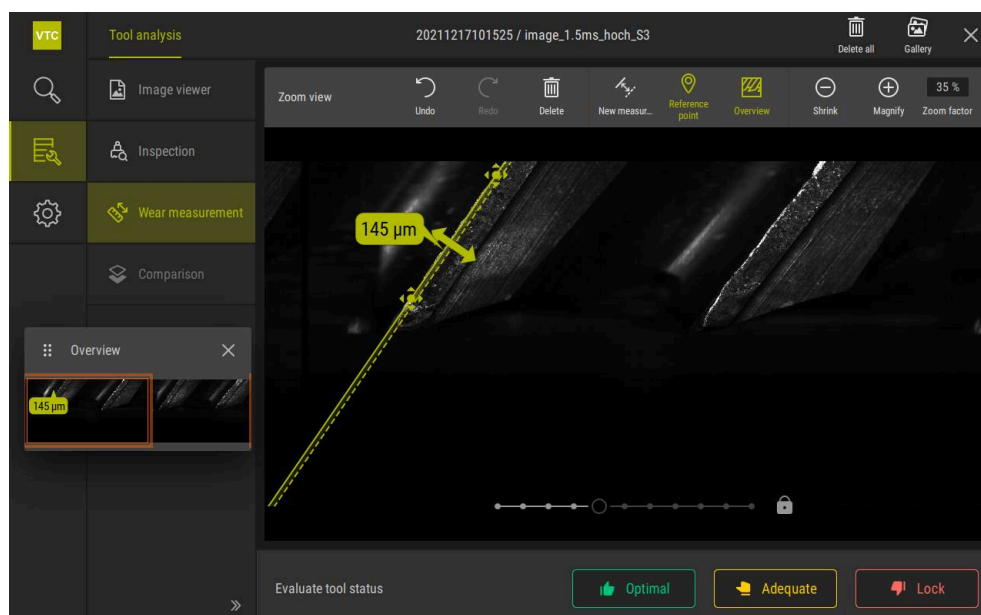





Figure 21: Flank-wear mode

## Operating elements in Flank-wear mode

The following operating elements are available in **Wear measurement** mode:

Operating element	Explanation
<b>Tool status</b>	<p>Defines the tool status; the following options are available:</p> <ul style="list-style-type: none"> <li>■ <b>Optimal</b> (green)</li> <li>■ <b>Adequate</b> (yellow)</li> <li>■ <b>Lock</b> (red)</li> </ul>
	<p>Activates and deactivates the <b>New measurement</b></p> <p>This function allows you to visually measure the tool-flank wear.</p>
	<p><b>Referencepoint</b></p> <p>This function allows you to set a <b>Referencepoint</b> in the <b>Panorama</b> view.</p>
	<p><b>Overview</b></p> <p>This function shows or hides the <b>Overview</b>.</p>

## Working with the wear measurement

To get a microscopic view of the tool-flank wear and to measure it with **New measurement**:



- ▶ Select an image in **Single** or **Panorama** view
- ▶ Select **New measurement**
- ▶ Click the cutting edge in the image
- > A green line along the cutting edge is displayed
- > A green double arrow is displayed.
- ▶ To measure the tool-flank wear, tap the green double arrow
- > A dashed green line appears.
- ▶ Tap the dashed green line and drag it to the desired position



You can also directly drag the green double arrow.

- > The tool-flank wear is displayed.



- ▶ To adjust the brightness and contrast of the image, tap **Optimize**
- > The image view is adjusted.



- ▶ To magnify an image, tap **Magnify**
- > Gradually magnifies the image.
- > The image size is shown in percent.



- ▶ To minimize an image, tap **Shrink**
- > Gradually reduces the image.
- > The image size is shown in percent.
  
- ▶ To switch between the 100% view and the full-surface view in the window, double-tap the image



- For better orientation, you can set a **Referencepoint** in the **Panorama** view.
- Double-click the **Zoom view** to switch directly between the 100% view and the entire image.
- Press and hold the **Zoom view** to magnify the image detail in this area. After a short time, a zoom window appears that you can adjust by dragging.

### 8.6.4 Transferring wear values via an export file

You can export the flank-wear data as a CSV file and evaluate them in MS Excel. The **Export** function is available in the **Group** menu level.

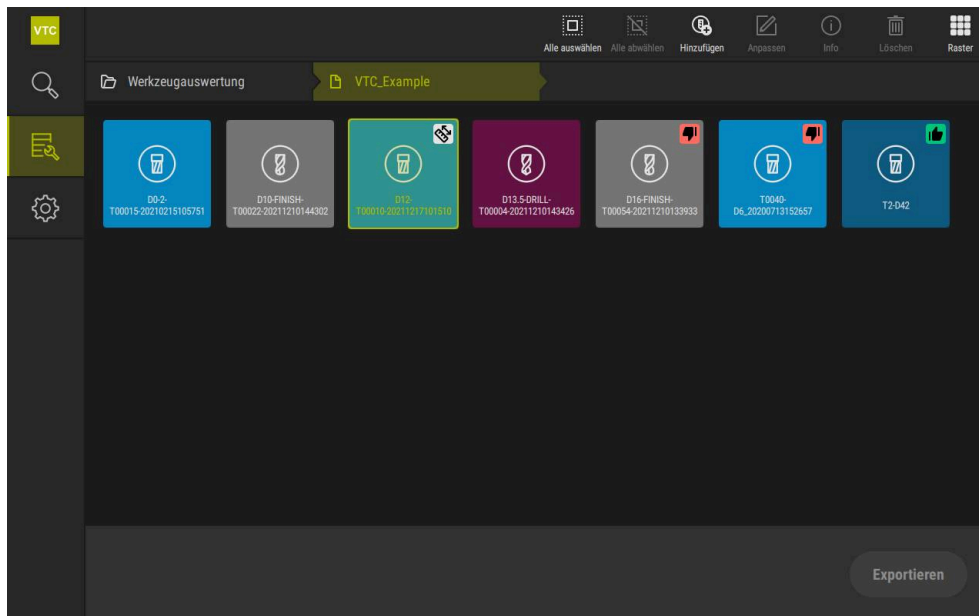

Figure 22: **Group** menu level

- ▶ To export the wear values of a tool, long-press the desired tool
- > The tool is highlighted.
- > The **Export** function is shown in green.

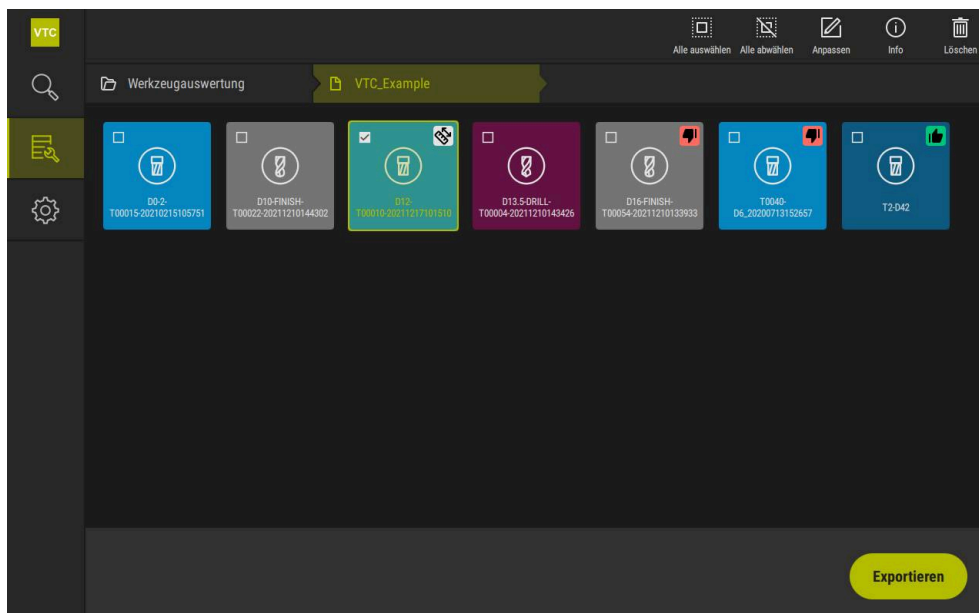

Figure 23: Selecting the tool in the **Group** menu level

- ▶ To define data for the CSV file, tap **Export**
- > The **Export** dialog opens.

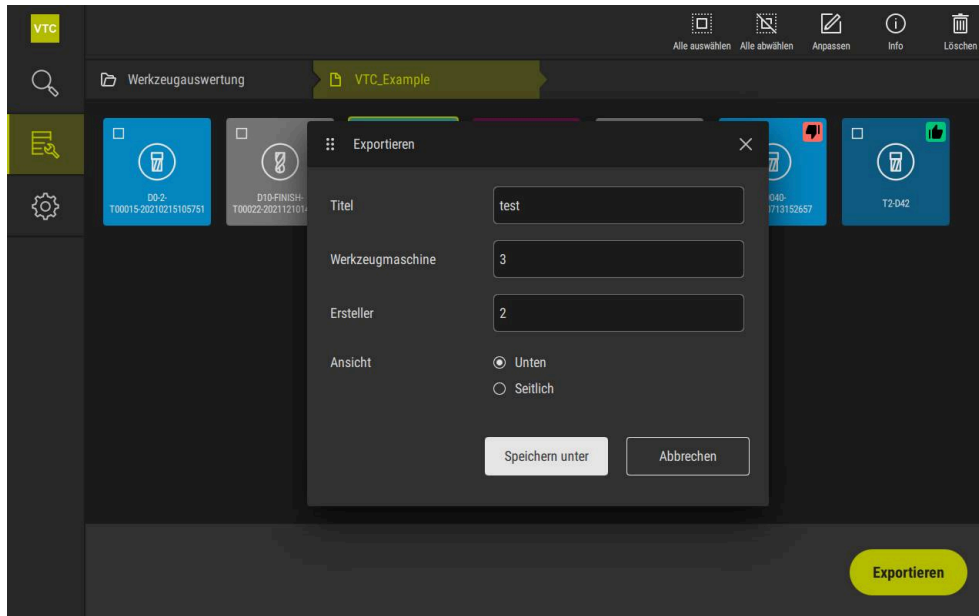

Figure 24: **Export** dialog

- ▶ To enter values, tap an input field
- > The input field is highlighted.
- > The screen keyboard is displayed.
- ▶ Enter text or numbers
- ▶ To apply the values, confirm the entry with **RET**
- > The values are displayed
- > The screen keyboard disappears.
- ▶ In **View** select whether the images were measured from the **Bottom** or **Lateral** view.
- > **Save as** is displayed.

## 8.6.5 Working in Comparison mode



The **Comparison** mode is only available for image series from cycles.

In **Comparison** mode, you can display a current image and a reference image next to each other. For better wear inspection, this comparison view can be magnified synchronously and adjusted in the display.

To work with the **Comparison** mode:

- ▶ Tap **Comparison**
- ▶ Tap the desired image
- > The comparison view is opened.



- ▶ To magnify an image, tap **Magnify**
- > Gradually magnifies the image.
- > The image size is shown in percent.



- ▶ To minimize an image, tap **Shrink**
- > Gradually reduces the image.
- > The image size is shown in percent.

- ▶ To switch between the 100% view and the full-surface view in the window, double-tap the image



Overlaying images

- ▶ Tap **Overlay**
- > In the **Current image** area, the image is overlaid with a differential image.



Adjusting the representation

- ▶ Tap **Settings**
- > The **Settings** dialog box appears.
- ▶ The representation in the **Current image** area can be customized with the following parameters:
  - **Tolerance** specifies the limit value for image deviations
  - **Opacity** specifies the opacity of the color marking
  - **Color coding** shows an additional bar with the color information
- > The representation in the **Current image** area is customized accordingly.

Changing the comparison view

- ▶ Tap the < or > button
- > In the **Comparison image** area, the next image series is used for the comparison.
- > The overlaid image in the **Current image** setting is adjusted.

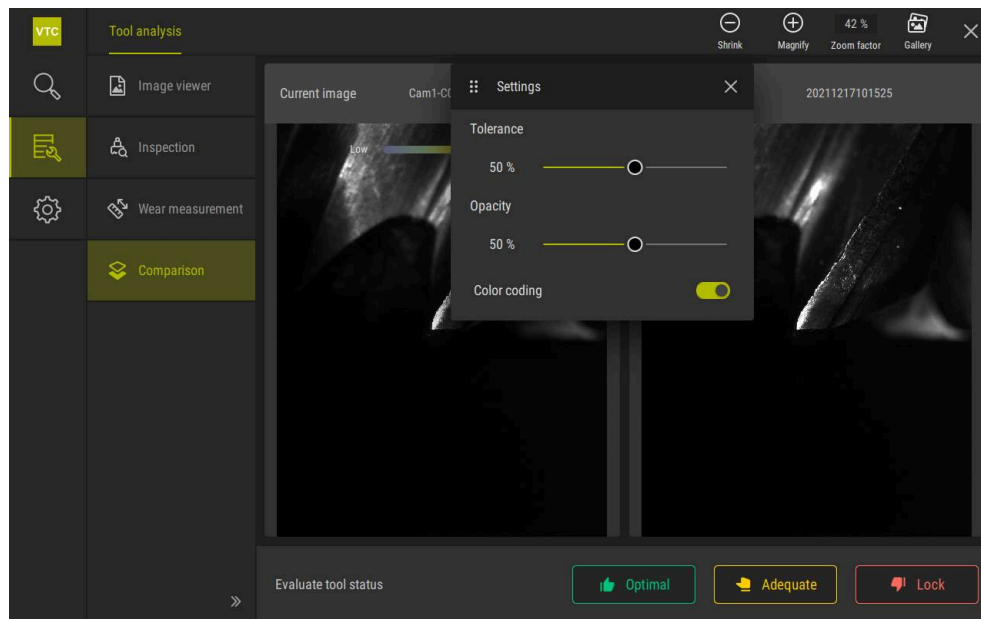

Figure 25: **Comparison** mode



To change the current image:

- ▶ Tap **gallery**
- > All image series for this tool are shown in a strip
- ▶ Select another series or image
- > The current image is changed.



# 9

**Settings**

## 9.1 Overview

This chapter describes settings for configuring the operation and representation mode.

### 9.1.1 Software information

Path: **Settings ► General ► Software information**

The overview displays basic information about the software.

Parameter	Displays the information
Product designation	Product designation of the software
Serial number	Serial number of the software
Version	Version number of the software
Built on	Software creation date
Last update on	Date of most recent software update

### 9.1.2 Image database

**Settings ► General ► Image database**

The overview shows the paths where the images were saved.

Parameter	Displays the information
Path to the database	Path on any hard disk in which the images were saved
Default path to the database	Resetting the path to the default path

### 9.1.3 Sounds

**Settings ► General ► Sounds**

The available sounds are grouped into categories. The sounds differ within a category.

Parameter	Explanation
Speaker	<ul style="list-style-type: none"> <li>■ Settings: <b>ON</b> or <b>OFF</b></li> <li>■ Default setting: <b>ON</b></li> </ul>
Speaker volume	Volume of the product's speaker <ul style="list-style-type: none"> <li>■ Setting range: <b>0 % ... 100 %</b></li> <li>■ Default setting: <b>50 %</b></li> </ul>
Message and Error	Sound to be played when a message is displayed When you select a setting, the associated sound is played <ul style="list-style-type: none"> <li>■ Settings: <b>Standard, Guitar, Robot, Outer space, No sound</b></li> <li>■ Default setting: <b>Standard</b></li> </ul>
Touch tone	Sound to be played when using a touch element When you select a setting, the associated sound is played <ul style="list-style-type: none"> <li>■ Settings: <b>Standard, Guitar, Robot, Outer space, No sound</b></li> <li>■ Default setting: <b>Standard</b></li> </ul>

## 9.1.4 Units

Settings ► General ► Units

Parameter	Explanation
<b>Unit for linear values</b>	Unit of measure for linear values <ul style="list-style-type: none"> <li>■ Settings: <b>Millimeters</b> or <b>Inch</b></li> <li>■ Default setting: <b>Millimeters</b></li> </ul>
<b>Rounding method for linear values</b>	Rounding method for linear values Settings: <ul style="list-style-type: none"> <li>■ <b>Commercial</b>: Decimal places from 1 to 4 are rounded down, decimal places from 5 to 9 are rounded up</li> <li>■ <b>Round off</b>: Decimal places from 1 to 9 are rounded down</li> <li>■ <b>Round up</b>: Decimal places from 1 to 9 are rounded up</li> <li>■ <b>Truncate</b>: Decimal places are truncated without rounding up or down</li> <li>■ <b>Round to 0 and 5</b>: Decimal places <math>\leq 24</math> or <math>\geq 75</math> are rounded to 0, decimal places <math>\geq 25</math> or <math>\leq 74</math> are rounded to 5</li> <li>■ Default setting: <b>Commercial</b></li> </ul>
<b>Decimal places for linear values</b>	Number of decimal places for linear values Setting range: <ul style="list-style-type: none"> <li>■ <b>Millimeters: 0 ... 5</b></li> <li>■ <b>Inch: 0 ... 7</b></li> </ul> Default value: <ul style="list-style-type: none"> <li>■ <b>Millimeters: 4</b></li> <li>■ <b>Inch: 6</b></li> </ul>
<b>Unit for angular values</b>	Unit for angular values Settings: <ul style="list-style-type: none"> <li>■ <b>Radian</b>: Angles in radian (rad)</li> <li>■ <b>Decimal degrees</b>: Angles in degrees (<math>^{\circ}</math>) with decimal places</li> <li>■ <b>Deg-Min-Sec</b>: Angles in degrees (<math>^{\circ}</math>), minutes [<math>'</math>] and seconds [<math>''</math>]</li> <li>■ Default setting: <b>Decimal degrees</b></li> </ul>
<b>Rounding method for angular values</b>	Rounding method for decimal angular values Settings: <ul style="list-style-type: none"> <li>■ <b>Commercial</b>: Decimal places from 1 to 4 are rounded down, decimal places from 5 to 9 are rounded up</li> <li>■ <b>Round off</b>: Decimal places from 1 to 9 are rounded down</li> <li>■ <b>Round up</b>: Decimal places from 1 to 9 are rounded up</li> <li>■ <b>Truncate</b>: Decimal places are truncated without rounding up or down</li> <li>■ <b>Round to 0 and 5</b>: Decimal places <math>\leq 24</math> or <math>\geq 75</math> are rounded to 0, decimal places <math>\geq 25</math> or <math>\leq 74</math> are rounded to 5</li> <li>■ Default setting: <b>Commercial</b></li> </ul>

Parameter	Explanation
<b>Decimal places for angular values</b>	Number of decimal places for angular values Setting range: <ul style="list-style-type: none"> <li>■ <b>Radian: 0 ... 7</b></li> <li>■ <b>Decimal degrees: 0 ... 5</b></li> <li>■ <b>Deg-Min-Sec: 0 ... 2</b></li> </ul> Default value: <ul style="list-style-type: none"> <li>■ <b>Radian: 5</b></li> <li>■ <b>Decimal degrees: 3</b></li> <li>■ <b>Deg-Min-Sec: 0</b></li> </ul>
<b>Decimal separator</b>	Separator for the display of values <ul style="list-style-type: none"> <li>■ Settings: <b>Point</b> or <b>Comma</b></li> <li>■ Default setting: <b>Point</b></li> </ul>

### 9.1.5 Copyrights

Settings ► General ► Copyrights

Parameter	Meaning and function
<b>Open source software</b>	Display of the licenses of the software used

## 9.2 Sensors

This chapter describes settings for configuring the sensors.

Depending on the software options that have been activated on the product, various parameters are available for configuring the sensors.

### 9.2.1 Camera

Path: **Settings ► Sensors ► Camera**

The **Camera** menu shows a list of the virtual cameras.

### 9.2.2 Virtual camera or hardware camera

Settings ► Sensors ► Camera ► **Camera designation**

Parameter	Explanation
<b>Camera</b>	Shows the name of the camera
<b>Serial number</b>	Shows the serial number of the camera
<b>Sensor resolution</b>	Shows the resolution of the camera sensor
<b>Frames per second</b>	Shows the number of camera images per second
<b>Frames (successful/faulty)</b>	Shows the number of successful and faulty images taken since the last time the product was powered up
<b>Image directory</b>	Location in which the demo image is stored on the product (can only be set for virtual cameras) <ul style="list-style-type: none"> <li>■ Default setting: <b>Camera</b> folder in installation folder</li> </ul>

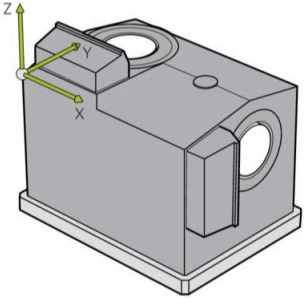
Parameter	Explanation
<b>Network settings</b>	<p>Network address and subnet mask of the network connection (can only be set for connected <b>(GigE)</b> camera)</p> <p>Settings:</p> <ul style="list-style-type: none"> <li>■ <b>IPv4 address</b>: network address</li> <li>■ <b>IPv4 subnet mask</b>: Subnet mask</li> <li>■ Default setting: <b>OFF</b></li> </ul> <div style="border: 1px solid black; padding: 5px; margin-top: 10px;"> <p><b>i</b> The camera must be in the same subnet as the product.</p> </div>
<b>Frame rate (fps)</b>	<p>Number of single images acquired per second</p> <ul style="list-style-type: none"> <li>■ Setting range: depending on connected camera</li> </ul>
<b>Default values</b>	Resets the <b>Pixel clock (MHz)</b> and <b>Frame rate (fps)</b> to the default values
<b>Focus points</b>	Shows the values of the camera's focal points
	
<b>Deactivate camera</b>	Deactivates the camera and live image

## 9.3 Interfaces

This chapter describes settings for configuring networks, network drives, and USB mass storage devices.

### 9.3.1 OPC UA-Server

Path: **Settings ► Interfaces ► OPC UA-Server**

Parameter	Explanation
Port	Entry of OPC UA interface

#### **NOTICE**

The port must not be blocked by the firewall

## 9.4 Service

### 9.4.1 Firmware information

#### Settings ► Service ► Firmware information

The information on the individual software modules is displayed for service and maintenance.

Parameter	Explanation
Core version	Version number of the microkernel
Boot ID	ID number of the boot process
C Library Version	Version number of the C library
Compiler Version	Version number of the compiler
Number of unit starts	Number of times the product was switched on
Qt build system	Version number of the Qt compilation software
Qt runtime libraries	Version number of the Qt runtime libraries
Kernel	Version number of the Linux kernel
Login status	Information on the logged-in user
SystemInterface	Version number of the system interface module
GuiInterface	Version number of the user interface module
TextDataBank	Version number of the text database module
NetworkInterface	Version number of the network interface module
OSInterface	Version number of the operating system interface module
CameraInterface	Version number of the camera interface module
VTCComServer	Version number of the VTC ComServer module
VTCDaBase	Version number of the VTC database module
VTCSettings	Version number of the VTC settings module
system.xml	Version number of the system parameters
info.xml	Version number of the information parameters
audio.xml	Version number of the audio parameters
network.xml	Version number of the network parameters
os.xml	Version number of the operating system parameters
runtime.xml	Version number of the runtime parameters
users.xml	Version number of the user parameters
camera.xml	Version number of the camera parameters
vtcCameraSettings.xml	Version number of the VTC camera parameters
vtcDataBaseSettings.xml	Version number of the VTC database parameters
vtcDisplaySettings.xml	Version number of the parameters for the VTC representation
vtcLightSettings.xml	Version number of the parameters for the lighting
vtcServerSettings.xml	Version number of the VTC server parameters
GI Patch Level	Patch level of the golden image (GI)

## 9.4.2 Back up and restore

### Settings ► Service ► Back up and restore

The product's settings or user files can be backed up as a file so that they are available after a reset to the factory default settings has been performed or for installation on multiple products.

Parameters	Explanation
Restoring settings	Restoring of the backed up settings <b>Further information:</b> "Restoring settings", Page 123
Back up settings	Backing up of settings of the product <b>Further information:</b> "Back up settings", Page 122

## 9.4.3 Software options

### Settings ► Service ► Software options

Parameter	Explanation
Overview	Overview of all software options that are active on the product
Request options	Creation of a license key request that can be submitted to a HEIDENHAIN service agency <b>Further information:</b> "Requesting license key", Page 124
Request trial options	Creation of a license key request that can be submitted to a HEIDENHAIN service agency <b>Further information:</b> "Requesting license key", Page 124
Activate options	Activation of the software options via license key or license file <b>Further information:</b> "Activating a license key", Page 125

## 9.4.4 Tools

Path: Settings ► Service ► Tools

Parameter	Explanation
Remote access for screenshots	Activation of remote access for screenshots of the software <ul style="list-style-type: none"> <li>■ Settings: <b>ON</b> or <b>OFF</b></li> <li>■ Default setting: <b>OFF</b></li> </ul>
Hilfswerkzeuge	Access to auxiliary tools is only possible with a password

# 10

**Service and  
Maintenance**

## 10.1 Overview

This chapter describes the service functions of the software. You can save and restore your settings. You can also enable the software options.



The following steps must be performed only by qualified personnel.

**Further information:** "Personnel qualification", Page 14

## 10.2 Back up settings

The settings can be backed up as a file to make them available after a reset to the factory default settings or for installation on multiple products.



- ▶ Tap **Settings** in the main menu



- ▶ Tap **Service**
- ▶ Open in succession:
  - **Back up and restore**
  - **Back up settings**
- ▶ Tap **Complete backup**
- ▶ If required, connect a USB mass storage device (FAT32 format) to a USB port
- ▶ Select the folder to which you want to copy the configuration file
- ▶ Specify a name for the configuration data (e.g., "<yyyy-mm-dd>\_config")
- ▶ Confirm your input with **RET**
- ▶ Tap **Save as**
- ▶ Tap **OK** to confirm the successful backup of the configuration
- > The configuration file has been backed up.

**Further information:** "Back up and restore", Page 120

## 10.3 Restoring settings

Backed-up settings can be reloaded. The current configuration of the software is replaced in the process.



- ▶ Tap **Settings** in the main menu
- ▶ Open in succession:
  - **Service**
  - **Back up and restore**
  - **Restoring settings**
- ▶ Tap **Complete restoration**
- ▶ If required, connect a USB mass storage device to a USB port
- ▶ Navigate to the folder containing the backup file
- ▶ Select the backup file
- ▶ Tap **Select**
- ▶ Confirm the successful transfer with **OK**
- > The software is terminated.

## 10.4 Activating Software options

You can activate additional **Software options** via a **License key**.



You can view the enabled **Software options** on the overview page.  
**Further information:** "Checking the Software options", Page 126

## 10.5 Requesting license key

You can request a license key by using the following procedure:

- Creating a license key request

### Creating a license key request



- ▶ Tap **Settings** in the main menu



- ▶ Tap **Service**
- ▶ Tap **Software options**
- ▶ To request a software option that is available for a fee, tap **Request options**
- ▶ To request a free trial option, tap **Request trial options**
- ▶ To select the desired software option, tap its check mark or use + and - to select the number of options



- ▶ To deselect an entry, tap the check mark for the respective software option

- ▶ Tap **Creating a request**
- ▶ In the dialog box, select the storage location in which you want to save the license key request
- ▶ Enter a suitable file name
- ▶ Confirm your input with **RET**
- ▶ Tap **Save as**
- > The license key request is created and saved in the selected folder.
- ▶ Safely remove USB stick
- ▶ Contact a HEIDENHAIN service agency and submit the file you created in order to request a license key
- > The license key and the license file are generated and submitted by e-mail

## 10.6 Activating a license key

You can activate a license key by

- Reading the license key from the provided license file into the product
- Entering the license key manually into the product

### 10.6.1 Uploading license key from license file



- ▶ Tap **Settings** in the main menu



- ▶ Tap **Service**
- ▶ Open in succession:
  - **Software options**
  - **Activate options**
- ▶ Tap **Read license file**
- ▶ Select the license file in the file system, on the USB mass storage device or on the network drive
- ▶ Confirm your selection with **Select**
- ▶ Tap **OK**
- > The license key is activated.
- ▶ Tap **OK**
- > You may need to restart the product, depending on the software option.
- ▶ Confirm the restart with **OK**
- > The activated software option is available.

### 10.6.2 Entering license key manually



- ▶ Tap **Settings** in the main menu



- ▶ Tap **Service**
- ▶ Open in succession:
  - **Software options**
  - **Activate options**
- ▶ Enter the license key into the **License key** input field
- ▶ Confirm the entry with **RET**
- ▶ Tap **OK**
- > The license key is activated.
- ▶ Tap **OK**
- > You may need to restart the product, depending on the software option.
- ▶ Confirm the restart with **OK**
- > The activated software option is available.

## 10.7 Checking the Software options

On the overview page, you can check which **Software options** are enabled for the product.



- ▶ Tap **Settings** in the main menu



- ▶ Tap **Service**
- ▶ Open in succession:
  - **Software options**
  - **Overview**
- > A list of enabled **Software options** is displayed.

## 11 Index

### A

Activating Software options..... 123

### C

#### Camera

Lighting palette..... 80

Live image..... 79

Settings..... 116

Comparison..... 110

#### Cycles

breakage check..... 36

Images..... 32

manual inspection..... 29

Measure tool completely..... 60

Measure tool length..... 47

Measure tool radius..... 51

Measure tool radius R2..... 55

Measure tool tip..... 63

measuring cutting edge

angles..... 39

Temperature compensation.... 44

VT calibration..... 42

VT Setup..... 28

### D

Decimal places..... 115

Decimal separator..... 115

#### Documentation

Addendum..... 9

Download..... 8

Operating Instructions..... 9

User's Manual..... 9

Double tap..... 69

Dragging..... 70

### E

Export..... 108

### G

#### Gestures

Double-tap..... 69

Dragging..... 70

Holding..... 70

Tapping..... 69

### H

Holding..... 70

### I

#### Image

Adding a series..... 96

Comparison view..... 110

Inspection view..... 102

Lighting..... 80

Parameters for single shot..... 84

See image..... 83

Single view..... 100

Wear measurement..... 105

Image database..... 114

Informational notes..... 10

Inspection view..... 102

### L

LEDs..... 80

#### License key

Activating..... 125

Entering..... 125

requesting..... 124

Lighting settings..... 82

#### Light setting

Extended..... 82

Simple..... 82

Live image..... 79

### M

#### Measuring cycles

Fundamentals..... 41

#### Menu

Manual tool inspection..... 73, 78

Settings..... 75, 114

Tool evaluation..... 74, 88

Menu level in tool evaluation..... 89

Mosaic view..... 103

#### Mouse actions

Dragging..... 70

Holding..... 70

Tapping..... 69

#### Mouse operation

Double-tap..... 69

### N

Navigation elements..... 89

### O

#### Obligations of the operating

company..... 15

#### Operating elements

Back..... 72

Close..... 72

Confirm..... 72

Drop-down list..... 72

Main menu..... 68

Plusminus button..... 72

Screen keyboard..... 71

Slider..... 72

Slide switch..... 72

Toggle switch..... 72

#### Operation

General operation..... 68

Operating elements..... 71

Operator..... 14

### P

Panoramic view..... 101, 103

Personnel qualification..... 14

### Q

Qualified personnel..... 14

### R

Recording..... 83

Rounding methods..... 115

### S

Safety precautions..... 10, 14

Series..... 96

#### Settings

backing up..... 122

Menu..... 75

Restoring..... 123

Single view..... 100

Software, installation..... 18

### T

Taking single shots..... 83

Tapping..... 69

#### Tool

Evaluate..... 95

Evaluating..... 105

Removing reflections virtually.....

101

#### Tool evaluation

Menu level..... 89

#### Traffic light

Tool status..... 105

### U

Units..... 115

Uploading license file..... 125

#### User interface

Manual tool inspection menu.. 73

Settings menu..... 75

Tool evaluation menu..... 74

### V

VTC cycles..... 26

### W

Wear control..... 110

Wear measurement..... 105

#### Wear values

Export..... 108

## 12 List of figures

Image 1:	Main menu of the user interface.....	68
Image 2:	Screen keyboard.....	71
Image 3:	Screen keyboard.....	
Image 4:	<b>Manual tool inspection</b> menu.....	73
Image 5:	<b>Tool evaluation</b> menu.....	74
Image 6:	<b>Settings</b> menu.....	75
Image 7:	<b>Manual tool inspection</b> menu.....	78
Image 8:	Live image of camera 2.....	79
Image 9:	<b>Lighting</b> dialog box.....	80
Image 10:	<b>New image</b> dialog box.....	83
Image 11:	<b>Blow off</b> dialog box.....	85
Image 12:	<b>Tool evaluation</b> menu.....	88
Image 13:	<b>Customize</b> dialog box.....	91
Image 14:	<b>Group</b> menu level.....	92
Image 15:	<b>Customize</b> dialog box.....	94
Image 16:	<b>Tools</b> menu level.....	95
Image 17:	<b>Customize</b> dialog box.....	97
Image 18:	Tool analysis.....	99
Image 19:	Illumination angle of the panoramic image.....	101
Image 20:	Panoramic image of small tools.....	101
Image 21:	<b>Inspection</b> mode.....	102
Image 22:	<b>Flank-wear</b> mode.....	105
Image 23:	<b>Group</b> menu level.....	108
Image 24:	Selecting the tool in the <b>Group</b> menu level.....	108
Image 25:	<b>Export</b> dialog.....	109
Image 26:	<b>Comparison</b> mode.....	111

# HEIDENHAIN

## DR. JOHANNES HEIDENHAIN GmbH

Dr.-Johannes-Heidenhain-Straße 5

**83301 Traunreut, Germany**

☎ +49 8669 31-0

☎ +49 8669 32-5061

info@heidenhain.de

**Technical support** ☎ +49 8669 32-1000

**Measuring systems** ☎ +49 8669 31-3104

service.ms-support@heidenhain.de

**NC support** ☎ +49 8669 31-3101

service.nc-support@heidenhain.de

**NC programming** ☎ +49 8669 31-3103

service.nc-pgm@heidenhain.de

**PLC programming** ☎ +49 8669 31-3102

service.plc@heidenhain.de

**APP programming** ☎ +49 8669 31-3106

service.app@heidenhain.de

**www.heidenhain.com**

