



HEIDENHAIN



Product Information

RCN 6000

Absolute Angle Encoder
with Integral Bearing and
Large Hollow Shaft

RCN 6000 series

Absolute angle encoder with

- Integral stator coupling
- Hollow through shaft (Ø 180 mm)
- System accuracy: $\pm 2''$

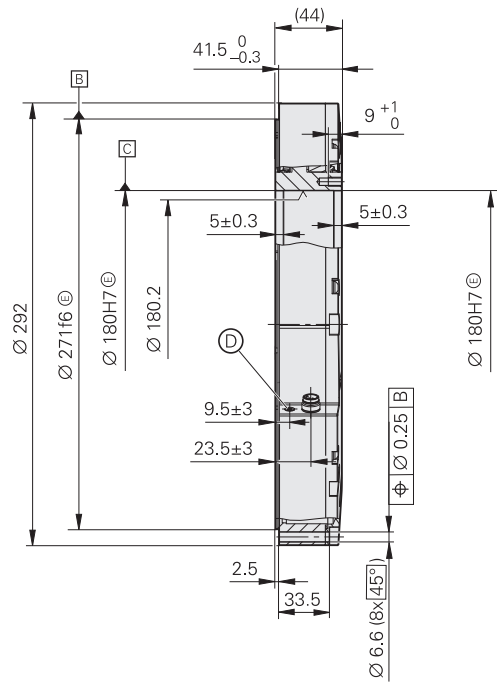
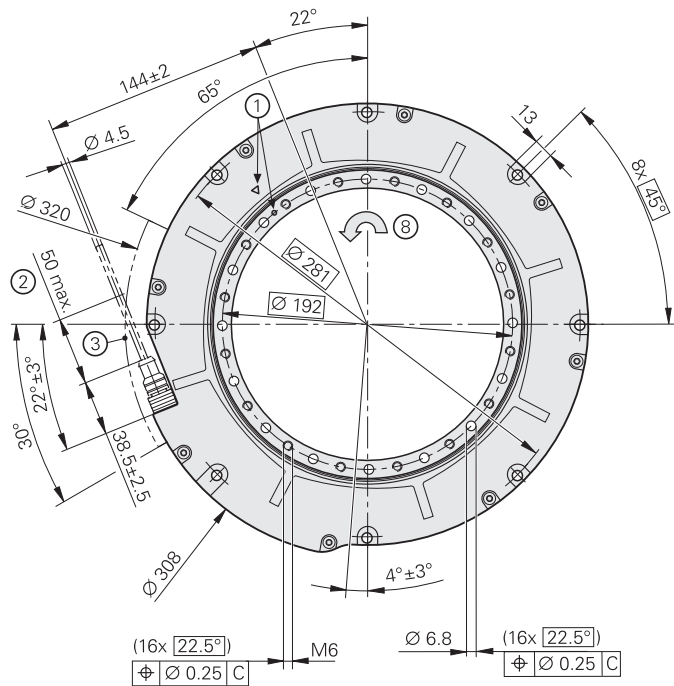
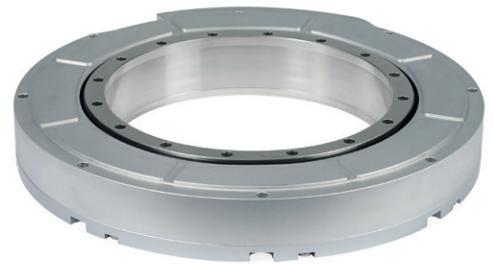

Shaft coupling via through hole

Ⓚ

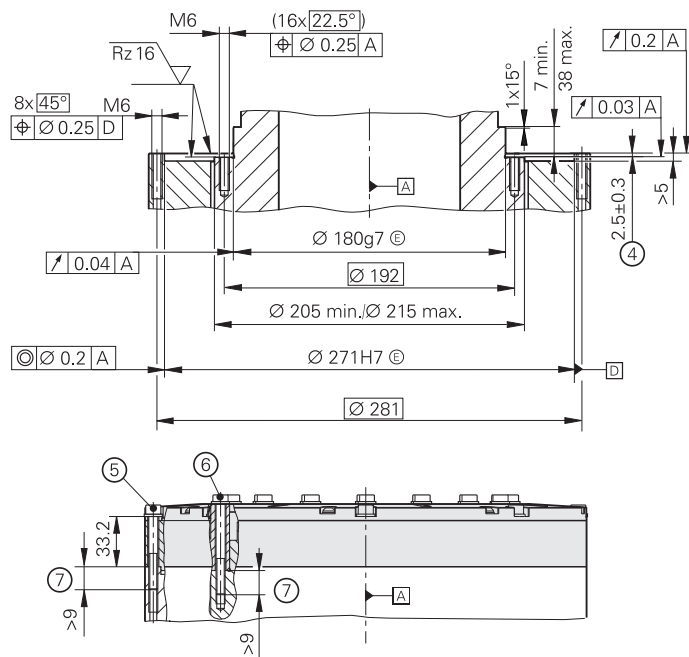

Shaft coupling via thread

Ⓚ

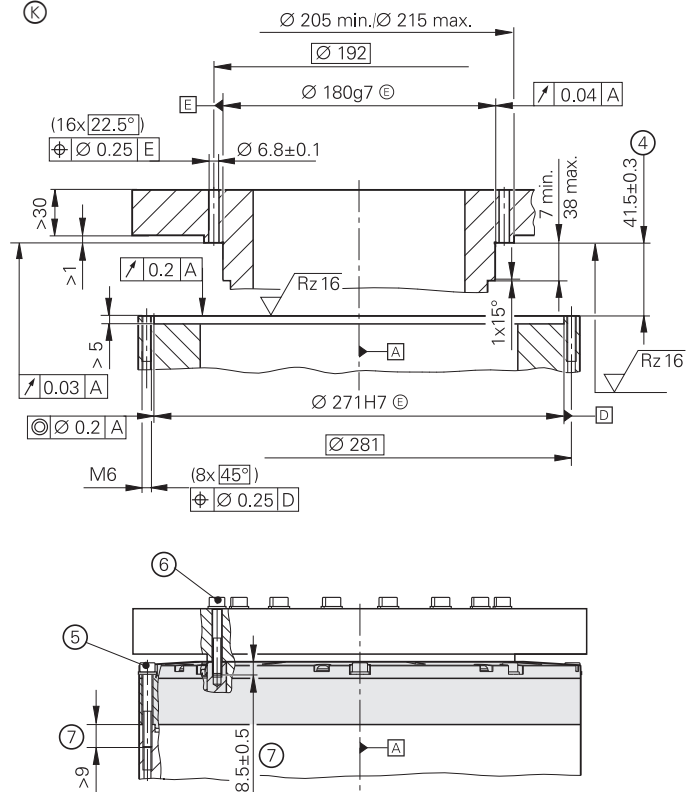

Ⓚ = Bearing of mating shaft

Ⓚ = Compressed air inlet

Ⓚ = Required mating dimensions

1 = Mark for 0° position $\pm 2.5^\circ$

2 = Cable support

3 = Free space for customer

4 = Tolerance specification includes mounting tolerances and thermal expansion. No dynamic movement permitted.

5 = Screw: ISO 4762-M6-8.8; tightening torque: 7 Nm ± 0.42 Nm
Washer: ISO 7092-6-200HV

6 = Screw: ISO 4762-M6-8.8; tightening torque: 8 Nm ± 0.48 Nm
Washer: ISO 7092-6-200HV

7 = Thread engagement

8 = Direction of shaft rotation for ascending position values

mm



Tolerancing ISO 8015
ISO 2768 - m H
 ≤ 6 mm: ± 0.2 mm

	Absolute RCN 6310 
Measuring standard	METALLUR graduation with absolute track and incremental track (19998 lines)
System accuracy	$\pm 2''$
Position error per signal period	$\leq \pm 0.3''$
Functional safety for applications with up to	<ul style="list-style-type: none"> • SIL 2 as per EN 61508 (further basis for testing: EN 61800-5-2) • Category 3, PL d as per EN ISO 13849-1:2015
PFH	$\leq 25 \cdot 10^{-9}$ (up to 2000 m above sea level)
Safe position ¹⁾	<i>Encoder:</i> $\pm 0.22^\circ$ (safety-related measuring step SM = 0.088°) <i>Mechanical coupling:</i> fault exclusion for the loosening of the housing/flange and hollow shaft
Interface	EnDat 2.2
Ordering designation	EnDat22
Position values per rev.	268435456 (28 bits)
Electrically permissible speed	≤ 800 rpm for continuous position value
Clock frequency Calculation time t_{cal}	≤ 16 MHz $\leq 5 \mu s$
Electrical connection	Separate adapter cable connectable to encoder via quick disconnect
Cable length ²⁾	≤ 100 m
Supply voltage	DC 3.6 V to 14 V
Power consumption ³⁾ (max.)	3.6 V: ≤ 1.1 W; 14 V: ≤ 1.3 W
Current consumption (typical)	5 V: 140 mA (without load)

¹⁾ Further tolerances may arise in the downstream electronics after position value comparison (contact mfr. of the downstream electronics).

²⁾ With HEIDENHAIN cable: ≤ 8 MHz

³⁾ See *General electrical information* in the *Interfaces of HEIDENHAIN Encoders* brochure

	Absolute RCN 6310 
Shaft	Hollow through shaft D = 180 mm
Mech. permissible speed	$\leq 200 \text{ rpm}^{4)}$
Starting torque (at 20 °C)	Typically $\leq 2.0 \text{ Nm}$
Moment of inertia	<i>Rotor (hollow shaft):</i> $40 \cdot 10^{-3} \text{ kgm}^2$; <i>stator (housing/flange):</i> $52 \cdot 10^{-3} \text{ kgm}^2$
Radial load (typical)	4.0 N per μm rotor-to-stator radial error
Permissible axial motion of measured shaft	$\pm 0.3 \text{ mm}^{5)}$
Natural frequency	$\geq 650 \text{ Hz}$
Vibration 55 Hz to 1400 Hz Shock: 6 ms	$\leq 200 \text{ m/s}^2$ (EN 60068-2-6) $\leq 200 \text{ m/s}^2$ (EN 60068-2-27)
Operating temperature	0 °C to 50 °C
Protection EN 60529	IP64
Mass	$\approx 6.5 \text{ kg}$

⁴⁾ Higher shaft speeds possible depending on the operating temperature (see *Mechanically permissible speed*)

⁵⁾ Range includes mounting tolerances and thermal expansion; no dynamic movement permitted

Mechanically permissible speed

The operating temperature (i.e., the temperature in the vicinity of the angle encoder) influences the permissible shaft speed (see graph). At a working temperature of 50 °C, for example, the maximum permissible speed is 200 rpm; at 20 °C, it is 500 rpm. Higher speeds of up to 800 rpm are permissible for short periods. In this case, consultation is required.

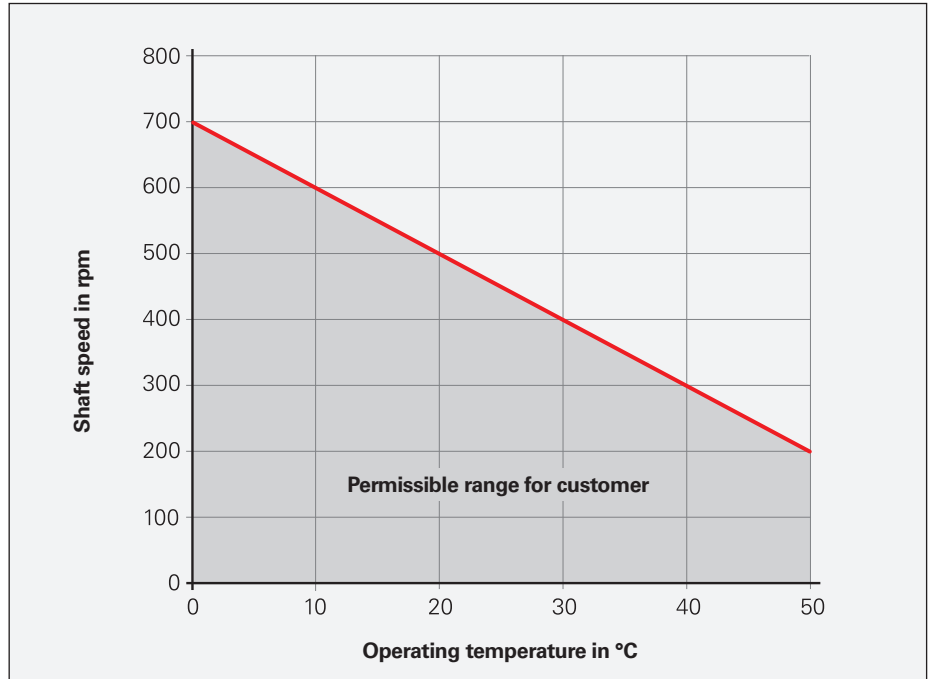

Permissible speed and operating temperature for the RCN 6000

Functional safety

Functionally safe axes

Driven axes on machine tools are generally a significant hazard for humans. It must be ensured that the machine does not make any uncontrolled movements, especially when a person is interacting with the machine (e.g., during workpiece setup). This requires position information about the axes in order for a safety function to be implemented. As an evaluating safety module, the control must be able to detect faulty position information and react accordingly.

Various safety strategies can be pursued, depending on the topology of the axis and the evaluation capabilities of the control. In a single-encoder system, for example, only one encoder per axis is evaluated for the safety function. But on axes with two encoders, such as a rotational axis with a rotary encoder and an angle encoder, the two redundant position values can be compared with each other in the controller. Safe fault detection can be ensured only if the controller and the encoder are properly matched and configured. Please note that the safety designs of control manufacturers differ from one another. As a result, the requirements to be fulfilled by the connected encoders may partially differ as well.

Type-examined encoders

HEIDENHAIN angle encoders with an integral bearing are successfully used on different controls in a wide variety of safety designs. This particularly applies to the type-examined RCN 6000 angle encoders with the EnDat interface. These encoders can be operated as single-encoder systems in conjunction with a suitable control in applications with the control category SIL 2 (as per EN 61508) or performance level "d" (as per EN ISO 13849). Unlike incremental encoders, the RCN 6000 absolute angle encoders always provide a safe absolute position value immediately after switch-on or after a power outage. Reliable position transmission is based on two independently generated absolute position values and on error bits provided to the safe control. The purely serial data transmission also provides other benefits, including greater reliability, improved accuracy, diagnostic capabilities and reduced costs through simpler connection technology.

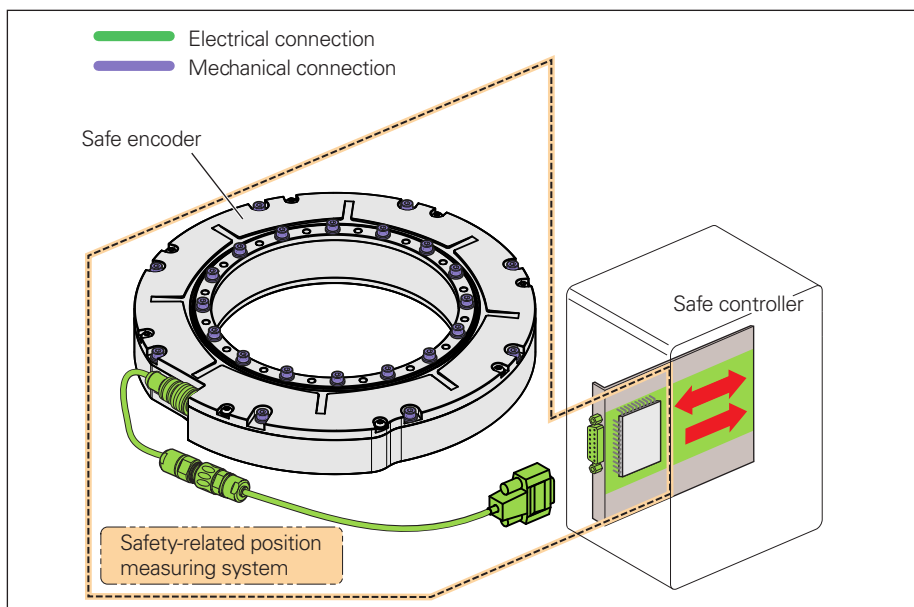

Safety-related position measuring system with mechanical connection and electrical interface



Further information:

The safety-related characteristic values are listed in the encoder specifications. These characteristic values are explained in the Technical Information document *Safety-Related Position Encoders*.

Fault exclusion for the loosening of the mechanical connection

Along with an encoder's data interface, its mechanical connection to the motor is also safety-relevant. The standard for electric motors, EN 61800-5-2, requires that the loosening of the mechanical connection between the encoder and the motor be considered as a fault. Since it cannot be guaranteed that the controller will detect such errors, fault exclusion for the loosening of the mechanical connection is required in many cases.

For the RCN 6000 series, the fastening method permits this type of fault exclusion. To find out more, please refer to the table below.

Fault exclusion is thereby possible for the loosening of the mechanical connection between the encoder and the machine shaft / customer fastening components. For designing the mechanical fault exclusion for other purely customer-side connections, the following encoder torque must be taken into account:

$$M_{Max} = J \cdot \alpha + 20 \text{ Nm}$$

J: Moment of inertia of the encoder (for the rotor or stator, see the specifications)

α: Max. angular acceleration in the application

Mechanical connection	Fastening ¹⁾	Safe position for the mechanical connection ²⁾
Housing/flange	M6 ISO 4762 8.8 screws	±0°
Hollow shaft Shaft coupling	M6 ISO 4762 8.8 screws	±0°

¹⁾ Use a suitable anti-rotation lock for the screw connection

²⁾ Fault exclusion is granted only for the explicitly mentioned mounting options

Mounting

(with mechanical fault exclusion)

Mounting

The housing of the RCN 6000 is firmly attached to the mounting surface of the machine by means of the mounting flange and the centering collar. Coupling of the hollow shaft with the machine shaft is performed via through holes or a thread.

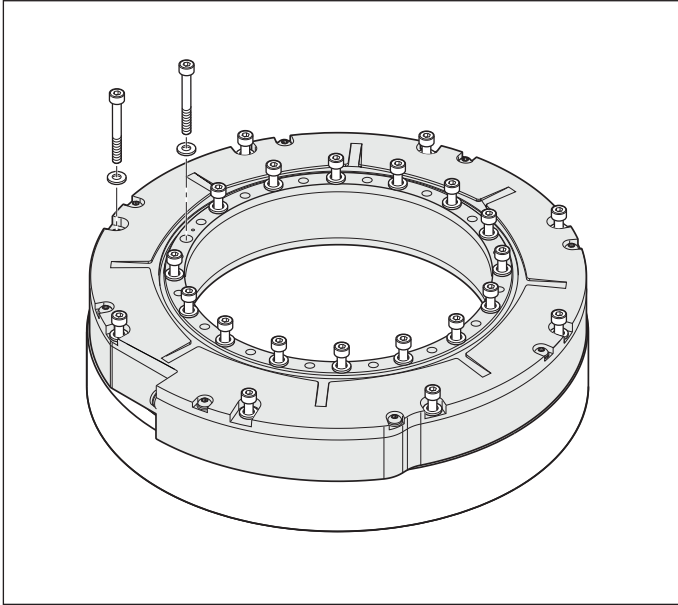

Shaft coupling via through holes

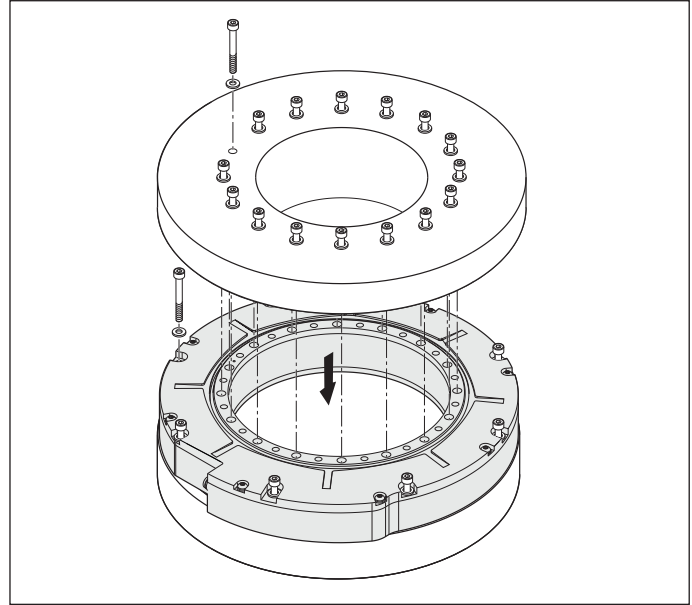

Shaft coupling via threads

Permissible angular acceleration

1000 rad/s²





Material

The materials stated in the following table must be used for the machine shaft and fastening components.

	Mating shaft	Mating stator
Material	Ferrous materials (steel/cast iron materials)	
Tensile strength R_m	$\geq 600 \text{ N/mm}^2$	$\geq 250 \text{ N/mm}^2$
Shear strength τ_a	$\geq 390 \text{ N/mm}^2$	$\geq 290 \text{ N/mm}^2$
Interface pressure p_G	$\geq 660 \text{ N/mm}^2$	$\geq 275 \text{ N/mm}^2$
Elastic modulus E	110000 N/mm ² to 215000 N/mm ²	
Coefficient of thermal expansion α_{therm} (at 20 °C)	10 · 10 ⁻⁶ K ⁻¹ to 17 · 10 ⁻⁶ K ⁻¹	
Mounting temperature	All of the information regarding screw connections is based on a mounting temperature of 15 °C to 35 °C	

Electrical connection

Cables

PUR adapter cables		$\varnothing 4.5 \text{ mm}; 1 \times (4 \times 0.09 \text{ mm}^2) + 4 \times 0.16 \text{ mm}^2; A_P = 2 \times 0.16 \text{ mm}^2$
Adapter cable with 8-pin M12 coupling (male)		729681-xx
Adapter cable with 15-pin D-sub connector (female)		1119394-xx
PUR adapter cables and connecting cable		$\varnothing 6 \text{ mm}; 2 \times (2 \times 0.09 \text{ mm}^2) + 2 \times (2 \times 0.16 \text{ mm}^2); A_P = 2 \times 0.16 \text{ mm}^2$
Connecting cable with 8-pin M12 connector (female) and 8-pin M12 coupling (male)		1036372-xx
Adapter cable with 8-pin M12 connector (female) and 15-pin D-sub connector (female)		1036521-xx
Adapter cable with 8-pin M12 connector (female) and 15-pin D-sub connector (male)		1036526-xx

A_P : Cross section of power supply lines

\varnothing : Cable diameter (for bend radii see the brochure *Interfaces of HEIDENHAIN Encoders*)

Note for safety-related applications: Only completely assembled HEIDENHAIN cables are qualified.

Do not modify cables or exchange their connectors without first consulting with HEIDENHAIN Traunreut.

For more cables, see the brochure *Angle Encoders with Integral Bearing*.

HEIDENHAIN

DR. JOHANNES HEIDENHAIN GmbH

Dr.-Johannes-Heidenhain-Straße 5

83301 Traunreut, Germany

☎ +49 8669 31-0

FAX +49 8669 32-5061

info@heidenhain.de

www.heidenhain.com

This Product Information document supersedes all previous editions, which thereby become invalid. The basis for ordering from HEIDENHAIN is always the Product Information document edition valid when the order is placed.



Further information:

Comply with the requirements described in the following documents to ensure correct and intended operation:

- Brochure: *Angle Encoders with Integral Bearing* 591109
- Brochure: *Interfaces of HEIDENHAIN Encoders* 1078628
- Brochure: *Cables and Connectors* 1206103
- Mounting instructions: *RCN 6000* 1234453
- Technical Information: *Safety-Related Position Measuring Systems* 596632

For implementation in a controller:

- Specification for safe controller 533095

For brochures and product information documents, visit www.heidenhain.com.