

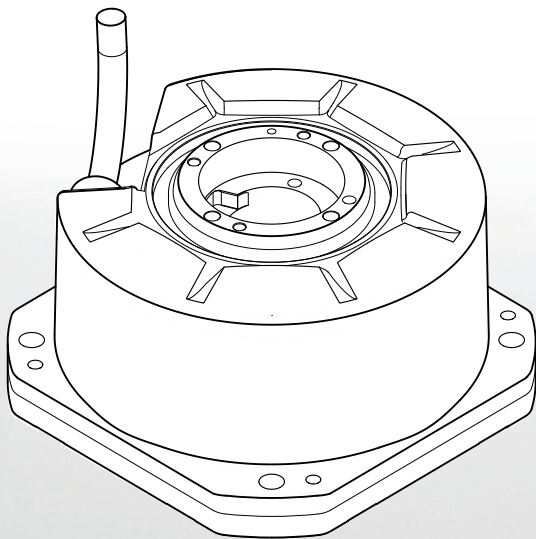

**HEIDENHAIN**



**RCN 2xx1**  
Mounting Instructions

**RIANA1: K**

## Table of contents

<b>1</b>	<b>Basic information.....</b>	<b>4</b>
1.1	Validity of the documentation.....	4
1.2	Target groups of the Mounting Instructions.....	4
1.3	Notes on reading the documentation.....	5
1.4	Symbols and fonts used for marking text.....	6
1.5	Notes in this documentation.....	7
1.6	Units and tolerances.....	7
<b>2</b>	<b>Safety.....</b>	<b>8</b>
2.1	Personnel qualification.....	8
2.2	General safety precautions.....	8
<b>3</b>	<b>Items supplied and accessories.....</b>	<b>10</b>
3.1	Items supplied.....	10
3.2	Mounting accessories.....	11

<b>4</b>	<b>Mounting</b>	<b>12</b>
4.1	Requirements and notes	12
4.1.1	Functional safety	13
4.2	Choosing the mounting variant	14
4.3	Mounting variant I: shaft coupling with mechanical fault exclusion, with ring nut	15
4.3.1	Materials and tools	15
4.3.2	Mounting the encoder	15
4.4	Mounting variant II: shaft coupling without mechanical fault exclusion, with ring nut	17
4.4.1	Materials and tools	17
4.4.2	Mounting the encoder	17
4.5	Mounting variant III: front-face shaft coupling with mechanical fault exclusion	19
4.5.1	Materials and tools	19
4.5.2	Mounting the encoder	19
4.6	Mounting variant IV: front-face shaft coupling without mechanical fault exclusion	22
4.6.1	Materials and tools	22
4.6.2	Mounting the encoder	22
<b>5</b>	<b>Final steps</b>	<b>24</b>
5.1	Connecting the encoder with the downstream electronics	24
5.1.1	To connect the encoder	24
<b>6</b>	<b>Removal</b>	<b>25</b>
6.1	Safety precautions regarding removal	25
6.2	Disassembly variants	26
6.3	Mounting variants I and II: shaft coupling with ring nut	27
6.3.1	Materials and tools	27
6.3.2	Removing the encoder	27
6.4	Mounting variant III: front-face shaft coupling with mechanical fault exclusion	29
6.4.1	Materials and tools	29
6.4.2	Removing the encoder	29
6.5	Mounting variant IV: front-face shaft coupling without mechanical fault exclusion	31
6.5.1	Materials and tools	31
6.5.2	Removing the encoder	31

## 1 Basic information

This chapter contains information about the product and the Mounting Instructions.

### 1.1 Validity of the documentation

These Mounting Instructions apply to RCN 2xx1.

- Before using the documentation, check whether the documentation and product model match. The designation of the product is printed on the ID label.

#### ID label

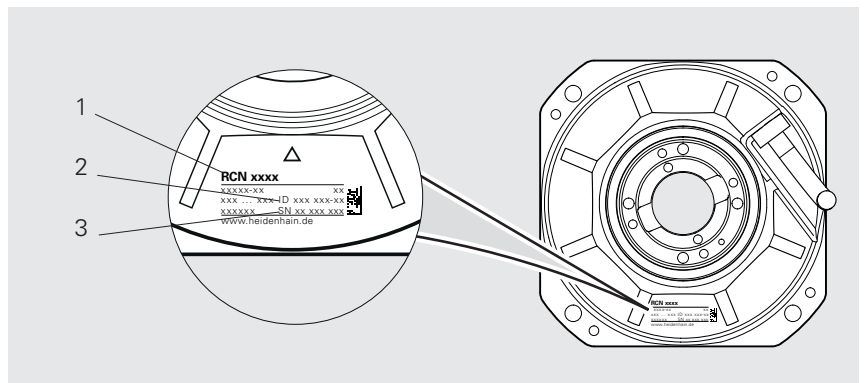

- 1 Product name
- 2 Product ID / Part number (ID)
- 3 Serial number (SN)

### 1.2 Target groups of the Mounting Instructions

The Mounting Instructions must be read and observed by every person who performs any of the following tasks:

- Design
- Mounting
- Removal

## 1.3 Notes on reading the documentation

### WARNING

#### **Fatal accidents, personal injury or property damage caused by non-compliance with the documentation!**

Failure to comply with the documentation may result in fatal accidents, personal injury or property damage.

- ▶ Read the documentation carefully from beginning to end
- ▶ Keep the documentation for future reference

The following table lists the various parts of the documentation in their order of reading priority.

Document type	Description
Addendum	An Addendum supplements or supersedes the corresponding contents of the Operating Instructions and, if applicable, of the Mounting Instructions. If an Addendum is included in the shipment, it has the highest priority for reading. All other documentation content retains its validity.
Operating Instructions	The Operating Instructions contain all of the information and safety instructions for the proper and intended operation of the device. The Operating Instructions (English language version) are included in delivery and can also be downloaded in other languages from <b><a href="http://www.heidenhain.com/documentation">www.heidenhain.com/documentation</a></b> . The Operating Instructions must be read prior to initial operation of the product. The Operating Instructions have the second highest priority for reading.
Mounting Instructions	The Mounting Instructions contain all the information and safety precautions needed for the proper mounting and installation of a product. The Mounting Instructions are not included in delivery and must be downloaded from <b><a href="http://www.heidenhain.com/documentation">www.heidenhain.com/documentation</a></b> . The Mounting Instructions have the third highest priority for reading.

#### **Would you like any changes, or have you found any errors?**

We are continuously striving to improve our documentation for you. Please help us by sending your suggestions to the following e-mail address:

**[userdoc@heidenhain.de](mailto:userdoc@heidenhain.de)**

## 1.4 Symbols and fonts used for marking text

In these instructions the following symbols and fonts are used for marking text:

Format	Meaning
▶ ...	Identifies an action and the result of this action
> ...	Example: <ul style="list-style-type: none"> <li>▶ Tilt the shipping brace to remove it <b>(c)</b></li> <li>&gt; The shipping brace has been removed now</li> </ul>
■ ...	Identifies an item of a list
■ ...	Example: <ul style="list-style-type: none"> <li>■ Solid contaminants: class 3</li> <li>■ Max. pressure dew point: class 4</li> </ul>

## 1.5 Notes in this documentation

### Safety precautions

Precautionary statements warn of hazards in handling the product and provide information on their prevention. Precautionary statements are classified by hazard severity and divided into the following groups:

#### DANGER

**Danger** indicates hazards for persons. If you do not follow the avoidance instructions, the hazard **will result in death or severe injury**.

#### WARNING

**Warning** indicates hazards for persons. If you do not follow the avoidance instructions, the hazard **could result in death or serious injury**.

#### CAUTION

**Caution** indicates hazards for persons. If you do not follow the avoidance instructions, the hazard **could result in minor or moderate injury**.

#### NOTICE

**Notice** indicates danger to material or data. If you do not follow the avoidance instructions, the hazard **could result in property damage**.

### Informational notes

Informational notes ensure reliable and efficient operation of the product. Informational notes are divided into the following groups:



The information symbol indicates a **tip**.  
A tip provides important additional or supplementary information.



The book symbol indicates a **cross reference**.  
A cross reference leads to external documentation, for example: further documentation from HEIDENHAIN or another supplier.

## 1.6 Units and tolerances

Unless otherwise specified, the dimensions stated in these Mounting Instructions are given in millimeters.

Unless otherwise specified, the tolerances stated in these Mounting Instructions conform to ISO 8015 and ISO 2768 standards.

mm



Tolerancing ISO 8015  
ISO 2768:1989-mH  
≤ 6 mm: ±0.2 mm

## 2 Safety

This chapter provides important safety information needed for the proper mounting and installation of the product.

### 2.1 Personnel qualification

Mounting, initial configuration and removal must be conducted by a qualified specialist under compliance with local safety regulations.

### 2.2 General safety precautions

#### WARNING

##### **Danger of electric shock due to connection to unsuitable downstream electronics!**

If you connect unsuitable downstream electronics to the product, fatal accidents or severe personal injuries can occur.

- ▶ Connect the product only to downstream electronics whose supply voltage comes from PELV systems

#### WARNING

##### **Live plug connections!**

If you disengage plug connections while the equipment is under power, this may result in fatal accidents or severe personal injury.

- ▶ Do not engage or disengage any connecting elements while the product is under power

#### WARNING

##### **Risk of injury from damaged or worn components!**

Safety functions can fail if damaged or worn components are installed. Failed safety functions can result in death or serious injury.

- ▶ Inspect the component for damage
- ▶ Do not use any damaged or worn components
- ▶ In case of replacement, repair the thread
- ▶ Use new screws, spring pins and nuts
- ▶ Secure screws and nuts with suitable material-bonding anti-rotation lock

#### WARNING

##### **Risk of injury due to improper assembly work!**

Safety functions can fail if assembly is performed incorrectly. Failed safety functions can result in death or serious injury.

- ▶ Further assembly requirements must be defined by the machine manufacturer
- ▶ Note the machine manufacturer's assembly requirements
- ▶ After assembly, perform an acceptance test according to the machine manufacturer's requirements

**⚠ WARNING****Risk of injury due to moving machine parts!**

Moving machine parts can cause accidents resulting in severe personal injury.

- ▶ Comply with local safety regulations and the machine manufacturer's requirements.

**NOTICE****Property damage due to mechanical stress!**

- ▶ Do not drop the product or subject it to major vibration
- ▶ Do not expose the product to mechanical stress
- ▶ Do not change the physical structure of the product

**NOTICE****Property damage due to electrical stress!**

- ▶ Do not engage or disengage any connecting elements while the product is under power
- ▶ Do not touch the contacts of the plug connections

**NOTICE****Electrostatic discharge (ESD)!**



This product contains electrostatically sensitive components that can be destroyed by electrostatic discharge (ESD).

- ▶ It is essential to observe the safety precautions for handling ESD-sensitive components
- ▶ Never touch connector pins without ensuring proper grounding
- ▶ Wear a grounded ESD wristband when handling the connections of the product

### 3 Items supplied and accessories

This chapter contains information on the items supplied and the available accessories of the product.

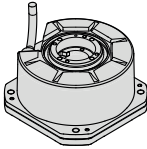
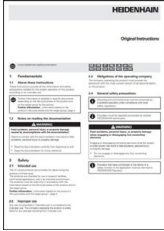
#### 3.1 Items supplied

Component	Figure
Encoder	
Operating Instructions	
Quality Inspection Document	

## 3.2 Mounting accessories



The following accessories can be ordered separately from HEIDENHAIN.



For more information, refer to the **Angle Encoders with Integral Bearing** brochure.

▶ [www.heidenhain.com/documentation](http://www.heidenhain.com/documentation)

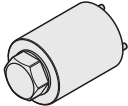
▶ Enter the document ID **591109**

Designation	ID	Figure
Mounting aid	530334-03	
Catch	817921-01	
Ring nut	336669-03	

## 4 Mounting

This chapter describes the mounting requirements, different mounting variants, and all other tasks necessary when mounting.

### 4.1 Requirements and notes

#### NOTICE

##### Property damage due to inappropriate tools!

Using inappropriate tools for mounting or removal of the encoder may cause damage to the encoder.

- ▶ Do not use hammers
- ▶ Do not use pointed or sharp-edged tools

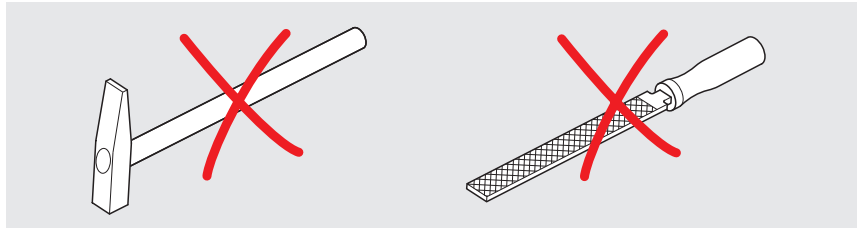

#### NOTICE

##### Property damage due to aggressive media

The use of aggressive media or organic solvents such as thinners, alcohol, or ligroin causes damage to the encoder.

- ▶ Never use aggressive media or organic solvents

**i** The mounting surfaces must be clean and free of burrs.

**i** All information on screw connections is based on a mounting temperature of 15 °C to 35 °C.

**📖** For more information on mounting, refer to the **Mating Dimensions** document.

- ▶ [www.heidenhain.com/documentation](http://www.heidenhain.com/documentation)
- ▶ Enter the product ID
- ▶ Open **Mating Dimensions**

#### Zero position

If the zero position is relevant in the application, pay attention to the alignment of the zero position marks during mounting.

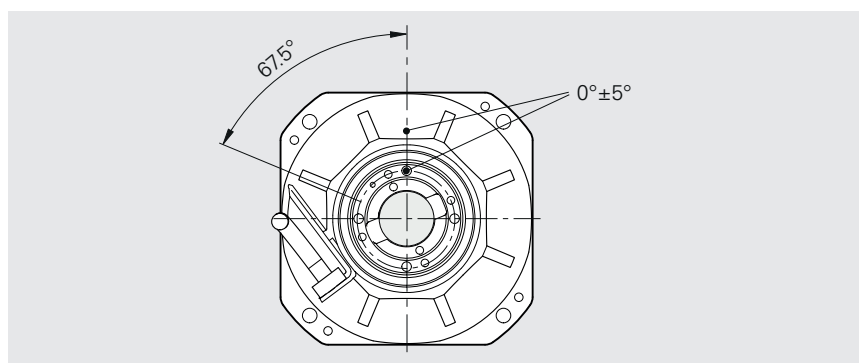

### 4.1.1 Functional safety

If the machine manufacturer requires fault exclusion for the loosening of the mechanical connection in order to use the encoder, the information on safe mechanical connection must be complied with. The corresponding information is described in the mounting variants "**with mechanical fault exclusion.**"



For more information, refer to the **Angle Encoders with Integral Bearing** brochure.

- ▶ [www.heidenhain.com/documentation](http://www.heidenhain.com/documentation)
- ▶ Enter the document ID **591109**

## 4.2 Choosing the mounting variant

### Mounting variants for the shaft coupling

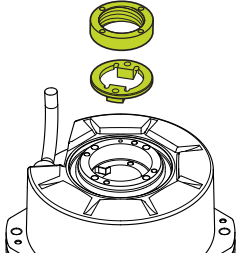
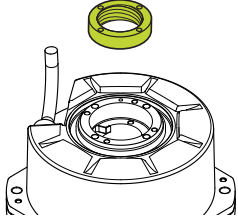
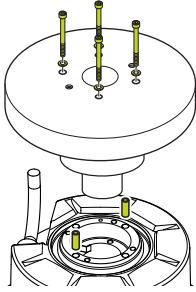
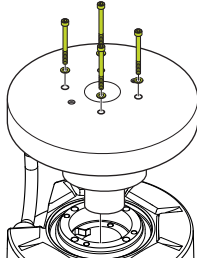
		Shaft coupling with mechanical fault exclusion	Shaft coupling without mechanical fault exclusion	
With ring nut		Mounting variant I <b>Page 15</b>		Mounting variant II <b>Page 17</b>
	At the front		Mounting variant III <b>Page 19</b>	

## 4.3 Mounting variant I: shaft coupling with mechanical fault exclusion, with ring nut

The mounting variant described in this chapter refers to mounting of the product by means of shaft coupling with mechanical fault exclusion, using a ring nut.

An overview of the mounting variants is provided on Page 14.

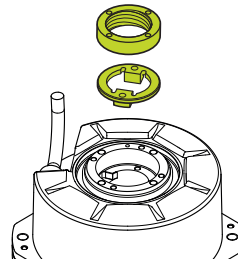

### 4.3.1 Materials and tools

For this task, the following materials and tools are needed:

#### Included in delivery

#### To be provided separately

- Ring nut
- Catch
- Mounting aid
- 4 screws (ISO 4762 – M4x20 – 8.8)
- 4 washers (ISO 7092 – 4 – 200HV)
- Torque wrench (hexagon socket for 3 mm)
- Torque wrench width 17
- Material bonding anti-rotation lock (medium strength, removable)
- Caliper gauge
- Cable fastening

### 4.3.2 Mounting the encoder

- ▶ Align the encoder with the machine shaft and slide it on
- ▶ Insert the catch (**M**) in the recess provided in the encoder and the machine shaft
- ▶ Make sure that the catch (**M**) is seated correctly in the recesses on the encoder and the machine shaft

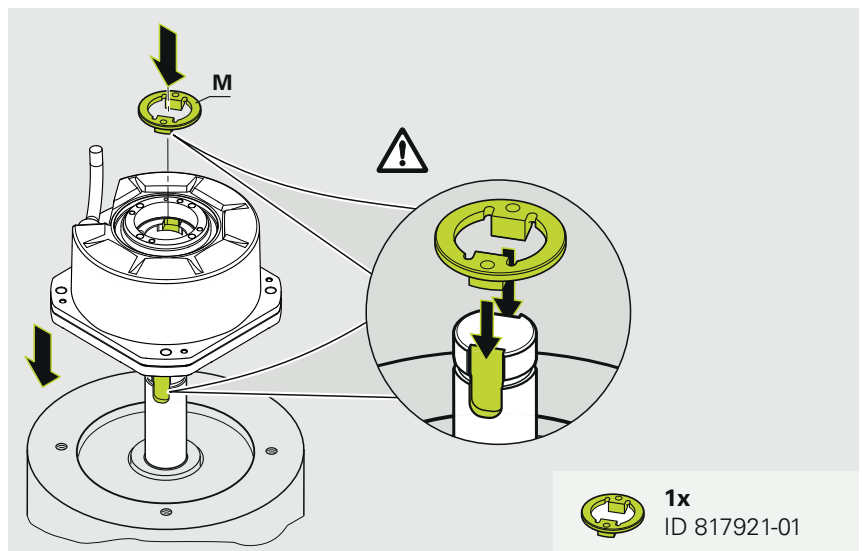

- ▶ Apply material bonding anti-rotation lock (medium strength, removable) to the screws
- ▶ Insert the screws and washers in the encoder
- ▶ Tighten the screws with the specified torque

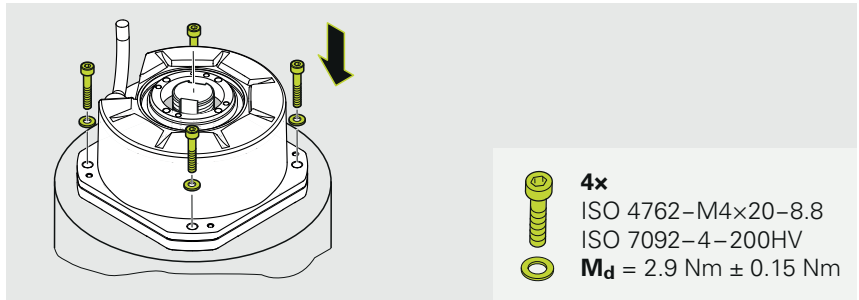

- ▶ Apply material bonding anti-rotation lock (medium strength, removable) to the thread of the ring nut
- ▶ Place the ring nut onto the machine shaft
- ▶ Place the mounting aid on the ring nut
- ▶ Using the mounting aid, tighten the ring nut with the specified torque

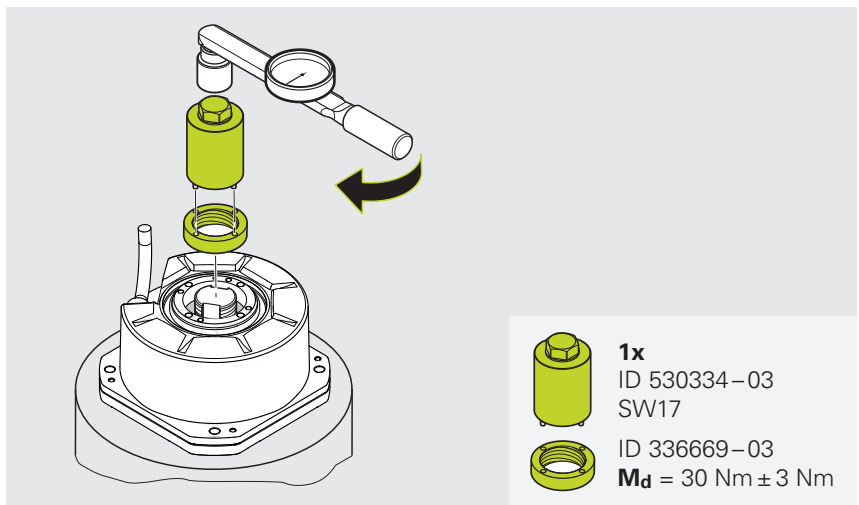

- ▶ Remove the mounting aid from the ring nut
- ▶ Ensure that the protrusion of the ring nut to the encoder is within the specified tolerance

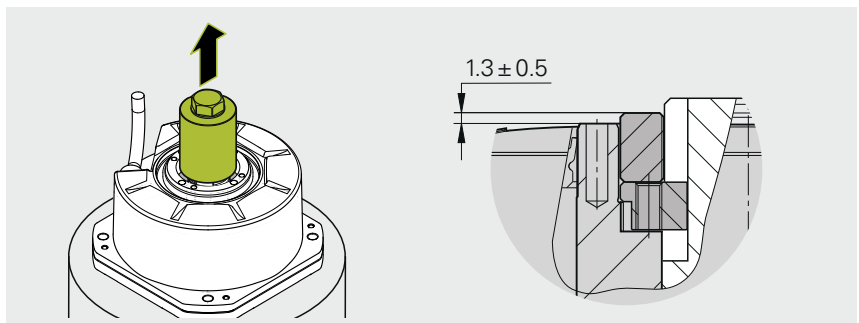

- ▶ Attach the cable fastening with the specified distance

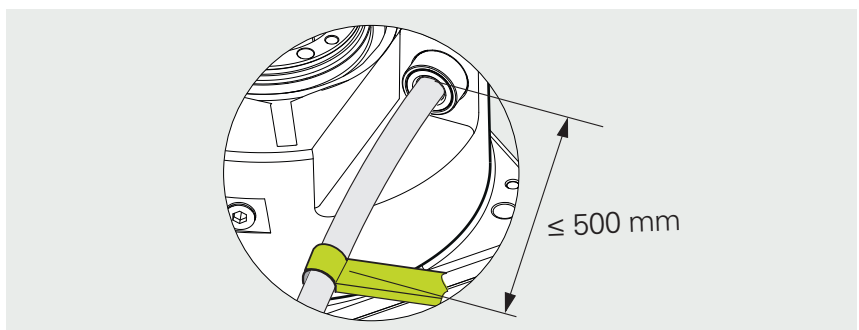

**Next step:** "To connect the encoder"

## 4.4 Mounting variant II: shaft coupling without mechanical fault exclusion, with ring nut

The mounting variant described in this chapter refers to mounting of the product by means of shaft coupling without mechanical fault exclusion, using a ring nut.

An overview of the mounting variants is provided on Page 14.

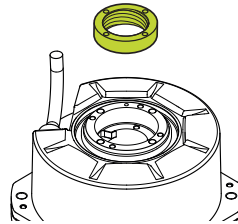

### 4.4.1 Materials and tools

For this task, the following materials and tools are needed:

#### Included in delivery

#### To be provided separately

- Ring nut
- Mounting aid
- 4 screws (ISO 4762 – M4×20 – 8.8)
- 4 washers (ISO 7092 – 4 – 200HV)
- Torque wrench (hexagon socket for 3 mm)
- Torque wrench width 17
- Material bonding anti-rotation lock (medium strength, removable)
- Caliper gauge
- Cable fastening

### 4.4.2 Mounting the encoder

- ▶ Slide the encoder onto the machine shaft
- ▶ Apply material bonding anti-rotation lock (medium strength, removable) to the screws
- ▶ Insert the screws and washers in the encoder
- ▶ Tighten the screws with the specified torque

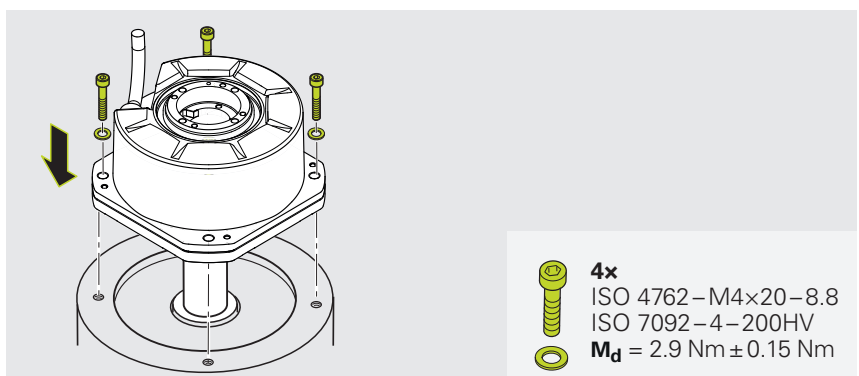

- ▶ Apply material bonding anti-rotation lock (medium strength, removable) to the thread of the ring nut
- ▶ Place the ring nut onto the machine shaft
- ▶ Place the mounting aid on the ring nut
- ▶ Using the mounting aid, tighten the ring nut with the specified torque
- ▶ Remove the mounting aid from the ring nut

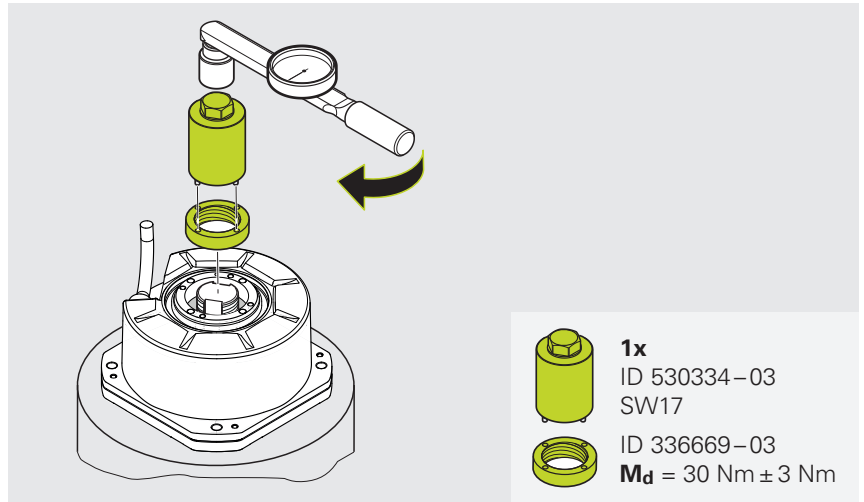

- ▶ Attach the cable fastening with the specified distance

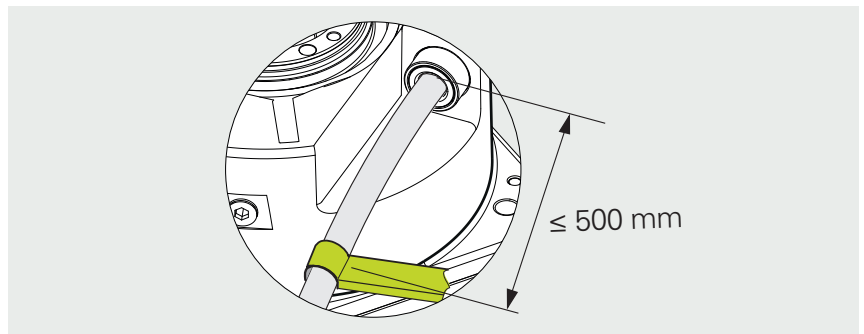

**Next step:** "To connect the encoder"

## 4.5 Mounting variant III: front-face shaft coupling with mechanical fault exclusion

The mounting variant described in this chapter refers to mounting of the product by means of front-end shaft coupling with mechanical fault exclusion.

An overview of the mounting variants is provided on Page 14.

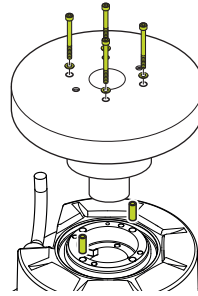

### 4.5.1 Materials and tools

For this task, the following materials and tools are needed:

#### Included in delivery

#### To be provided separately

- Mounting element (adapted to the design)
- 4 screws (ISO 4762 – M4×20 – 8.8)
- 4 washers (ISO 7092 – 4 – 200HV)
- 4 screws (ISO 4762 – M3×(L-4.5) – 8.8)
- 4 screws (ISO 4762 – M3×(L+4.5) – 8.8)
- 4 washers (ISO 7092 – 3 – 200HV)
- 2 spring pins (ISO 8752 – 2.5×10 – St)
- Torque wrench (hexagon socket, 2.5 mm and 3 mm)
- Material bonding anti-rotation lock (medium strength, removable)
- Caliper gauge
- Cable fastening

### 4.5.2 Mounting the encoder

- ▶ Apply material bonding anti-rotation lock (medium strength, removable) to the screws
- ▶ Insert the screws and washers in the encoder
- ▶ Tighten the screws with the specified torque

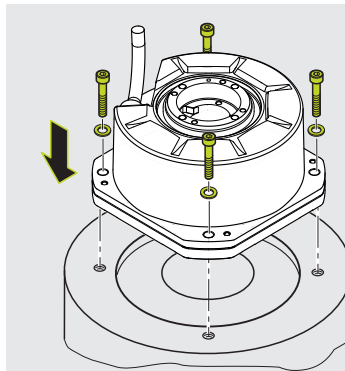

- 4x**  
ISO 4762 – M4×20 – 8.8  
ISO 7092 – 4 – 200HV
- M<sub>d</sub>** = 2.9 Nm ± 0.15 Nm

- ▶ Determine the dimension **(L)**
- ▶ For later determination of the screw length and the reference dimension

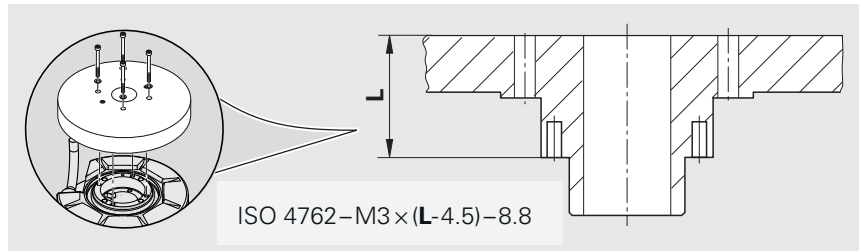

- ▶ Ensure that the spring pins **(S)** are free of burrs
- ▶ Align the slots of the spring pins tangentially toward each other **(W)** and insert them in the mounting element
- ▶ Ensure that the spring pins in the mounting element protrude by the specified length

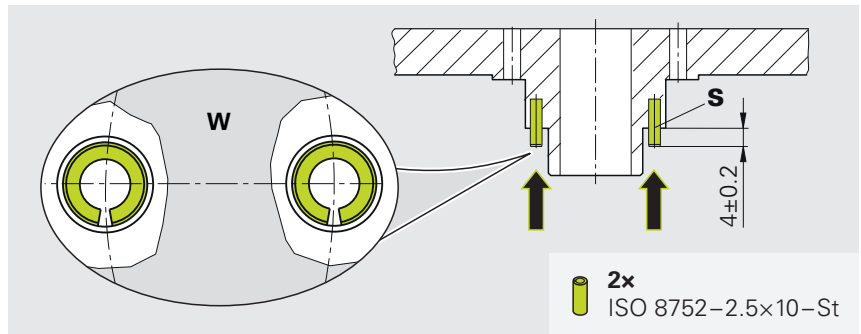

- ▶ Align the mounting element with the spring pins toward the spring pin holes **(C)** on the encoder
- ▶ Place the mounting element on the encoder and slightly push the spring pins into the spring-pin holes **(C)**

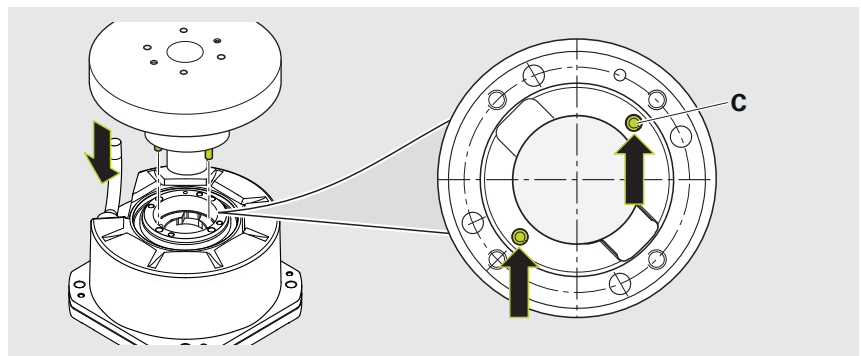

- ▶ Apply the material bonding anti-rotation lock (medium strength, removable) to the screws
- ▶ Insert the screws and washers into the mounting element

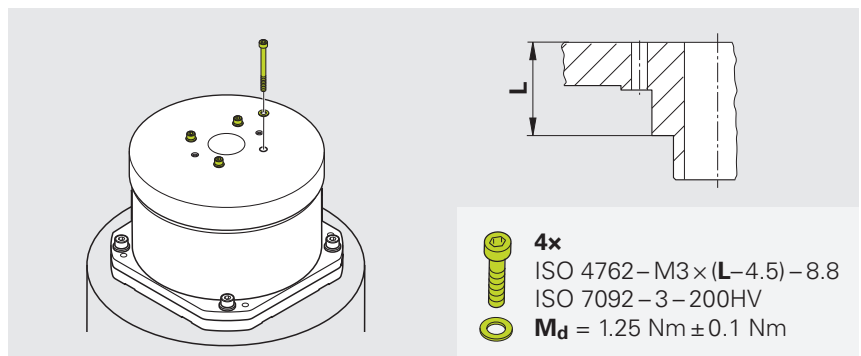

### NOTICE

#### Damage due to improper mounting of the mounting element

Improper mounting can lead to jamming of the mounting element, thus causing damage to the encoder.

- ▶ Tighten the screws only crosswise by half a turn at a time
  - ▶ Ensure that the mounting element does not get jammed in the encoder
- ▶ Tighten the screws crosswise, half a turn at a time, until the specified tightening torque is reached

- ▶ Determine the reference dimension **(Z)** through the back-off thread **(M3)**
- ▶ Ensure that the distances are within the specified tolerance

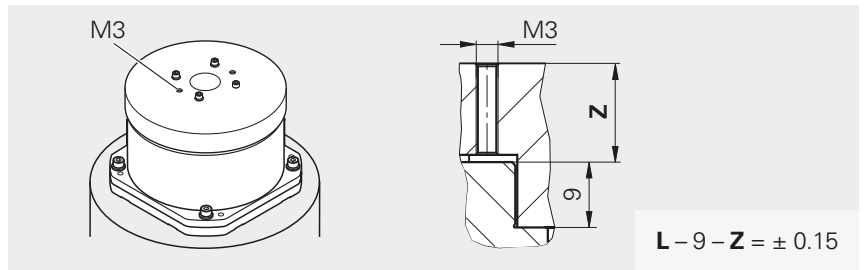

- ▶ Attach the cable fastening with the specified distance

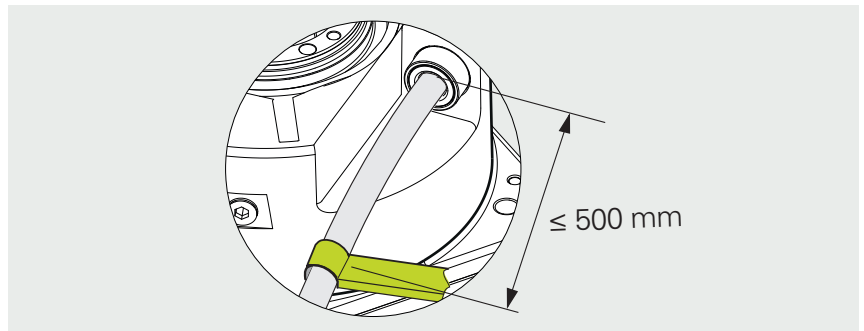

**Next step:** "To connect the encoder"

## 4.6 Mounting variant IV: front-face shaft coupling without mechanical fault exclusion

The mounting variant described in this chapter refers to mounting of the product by means of front-end shaft coupling without mechanical fault exclusion.

An overview of the mounting variants is provided on Page 14.

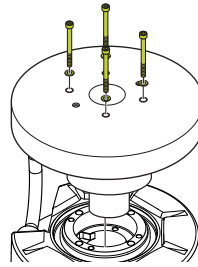

### 4.6.1 Materials and tools

For this task, the following materials and tools are needed:

#### Included in delivery

#### To be provided separately

- Mounting element (adapted to the design)
- 4 screws (ISO 4762 – M4×20 – 8.8)
- 4 washers (ISO 7092 – 4 – 200HV)
- 4 screws (ISO 4762 – M3×(L-4.5) – 8.8)
- 4 washers (ISO 7092 – 3 – 200HV)
- Torque wrench (hexagon socket, 2.5 mm and 3 mm)
- Material bonding anti-rotation lock (medium strength, removable)
- Caliper gauge
- Cable fastening

### 4.6.2 Mounting the encoder

- ▶ Apply material bonding anti-rotation lock (medium strength, removable) to the screws
- ▶ Insert the screws and washers in the encoder
- ▶ Tighten the screws with the specified torque

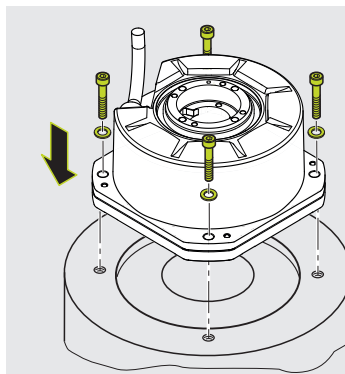

- 4x**  
 ISO 4762 – M4×20 – 8.8  
 ISO 7092 – 4 – 200HV  
**M<sub>d</sub>** = 2.9 Nm ± 0.15 Nm

- ▶ Determine the dimension (**L**)
- ▶ For later determination of the screw length

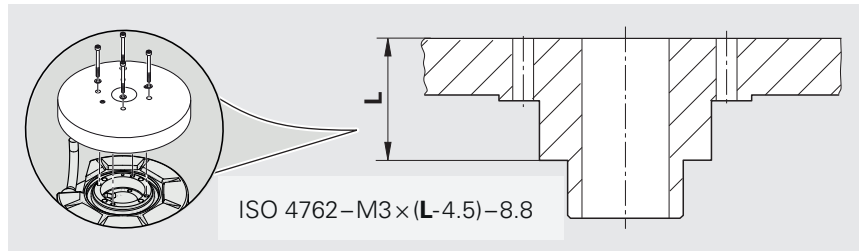

- ▶ Place the mounting element on the encoder. Pay attention to the orientation of the holes
- ▶ Apply the material bonding anti-rotation lock (medium strength, removable) to the screws
- ▶ Insert the screws and washers into the encoder

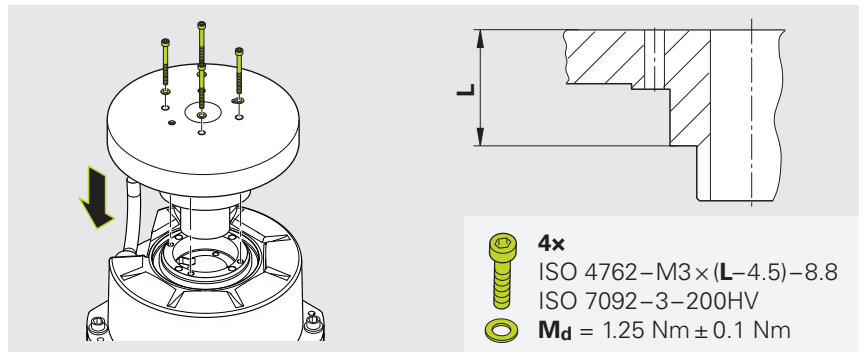

### NOTICE

#### Damage due to improper mounting of the mounting element

Improper mounting can lead to jamming of the mounting element, thus causing damage to the encoder.

- ▶ Tighten the screws only crosswise by half a turn at a time
  - ▶ Ensure that the mounting element does not get jammed in the encoder
- ▶ Tighten the screws crosswise, half a turn at a time, until the specified tightening torque is reached
  - ▶ Attach the cable fastening with the specified distance

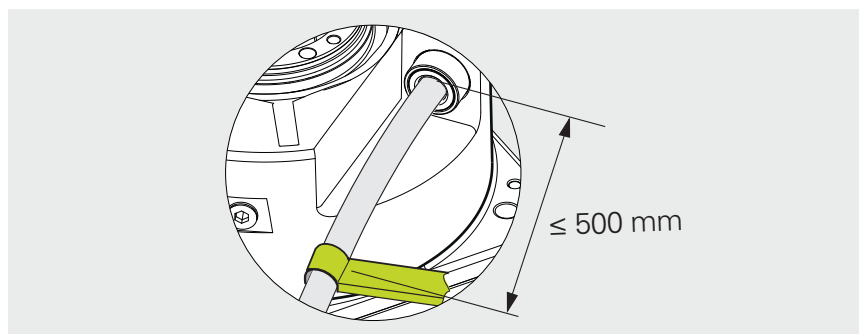

**Next step:** "To connect the encoder"

## 5 Final steps

### 5.1 Connecting the encoder with the downstream electronics

#### 5.1.1 To connect the encoder

#### WARNING

##### **Danger of electric shock due to plug connections under voltage!**

Connecting and disconnecting live cables and plug connections in the equipment can result in death or serious injury.

- Only connect and disconnect cables and plug connections when no current is flowing through them
- Disconnect the downstream electronics from power before connecting the product
- For cables without connectors, pay attention to the pin layout

#### **NOTICE**

##### **Property damage resulting from incorrect routing of the connecting cable!**

Connecting cables may become damaged as a result of incorrect routing.

- ▶ Observe the maximum permissible bend radii
- ▶ Do not cross connecting cables in drag chains
- ▶ Route connecting cables professionally

- ▶ Connect the encoder to the downstream electronics



For more information on the pin layout of the product, refer to the **Pin Layout** document

- ▶ [www.heidenhain.com/documentation](http://www.heidenhain.com/documentation)
- ▶ Enter the product ID
- ▶ Open the **Pin Layout**



For more information on sources of interference, refer to the **Interfaces of HEIDENHAIN Encoders** brochure.

- ▶ [www.heidenhain.com/documentation](http://www.heidenhain.com/documentation)
- ▶ Enter the document ID **1078628**



For more information on the cable characteristics and cable routing, refer to the **Cables and Connectors** brochure.

- ▶ [www.heidenhain.com/documentation](http://www.heidenhain.com/documentation)
- ▶ Enter the document ID **1206103**



For more information on the pin layouts of pre-assembled cables, refer to the **Cables and Connectors** brochure.

- ▶ [www.heidenhain.com/documentation](http://www.heidenhain.com/documentation)
- ▶ Enter the document ID **1206103**

## 6 Removal

This chapter describes the disassembly of the product.

### 6.1 Safety precautions regarding removal

#### WARNING

##### **Live plug connections!**

If you disengage plug connections while the equipment is under power, this may result in fatal accidents or severe personal injury.

- ▶ Do not engage or disengage any connecting elements while the product is under power

#### WARNING

##### **Risk of injury due to improper disassembly work!**

Safety functions can fail if disassembly is performed incorrectly. Failed safety functions can result in death or serious injury.

- ▶ Further disassembly requirements must be defined by the machine manufacturer
- ▶ Note the machine manufacturer's disassembly requirements

#### WARNING

##### **Risk of injury due to moving machine parts!**

Moving machine parts can cause accidents resulting in severe personal injury.

- ▶ Comply with local safety regulations and the machine manufacturer's requirements.

## 6.2 Disassembly variants

The removal procedure depends on the selected mounting variant.

### Mounting variants for the shaft coupling

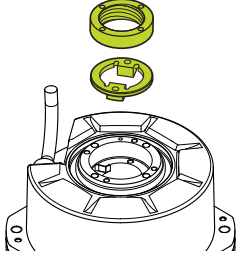
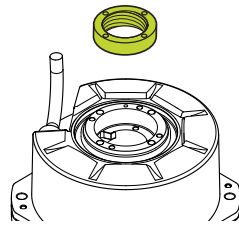
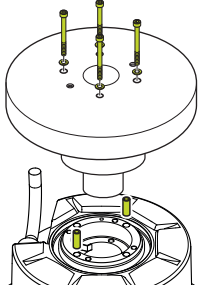
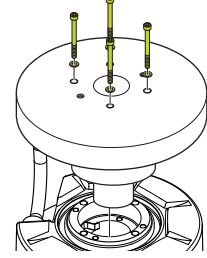
	Shaft coupling with mechanical fault exclusion	Shaft coupling without mechanical fault exclusion
With ring nut	 <p>Mounting variant I <b>Page 27</b></p>	 <p>Mounting variant II <b>Page 27</b></p>
At the front	 <p>Mounting variant III <b>Page 29</b></p>	 <p>Mounting variant IV <b>Page 31</b></p>

## 6.3 Mounting variants I and II: shaft coupling with ring nut

The mounting variant described in this chapter refers to removal of the product fastened by means of shaft coupling with a ring nut.

An overview of the mounting variants is provided on Page 26.

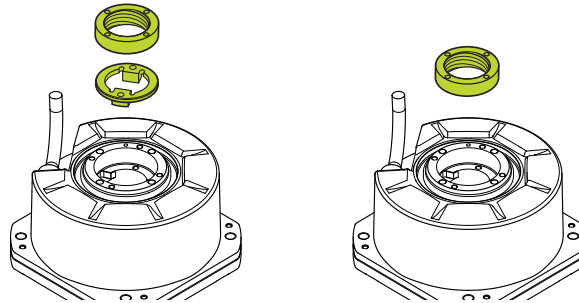

### 6.3.1 Materials and tools

For this task, the following materials and tools are needed:

#### Included in delivery

#### To be provided separately

- Mounting aid
- Torque wrench width 17
- Torque wrench (hexagon socket, 3 mm)

### 6.3.2 Removing the encoder

- ▶ Disengage the connecting element
- ▶ Loosen the cable fastening
- ▶ Place the mounting aid on the ring nut
- ▶ Loosen and remove the ring nut using the mounting aid
- ▶ Remove the catch (if applicable)

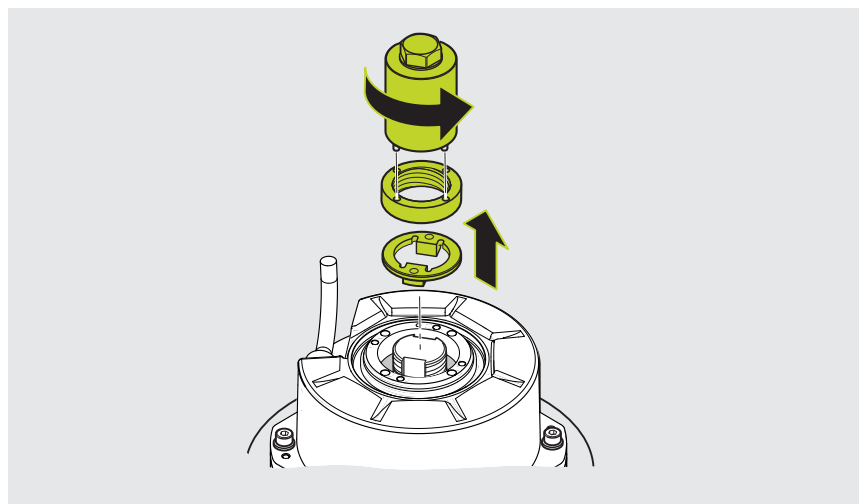

- ▶ Loosen the screws and remove them including the washers
- ▶ Remove the encoder

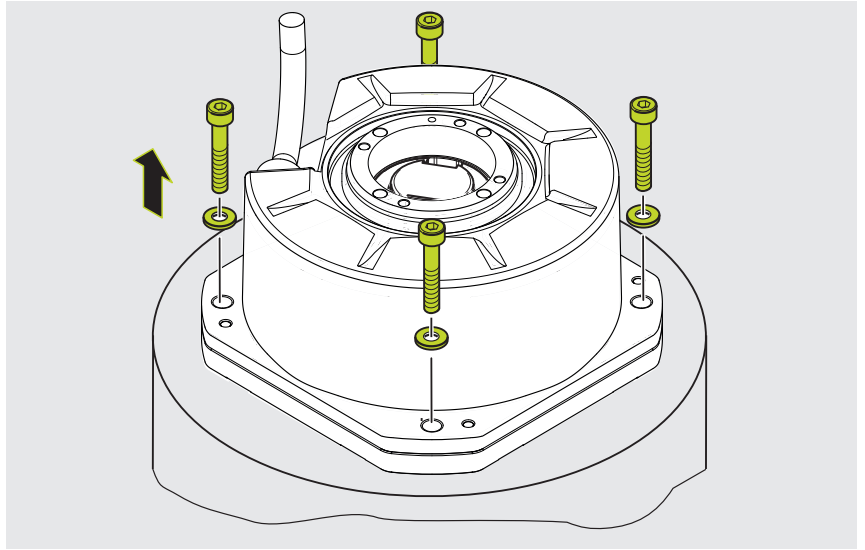

## 6.4 Mounting variant III: front-face shaft coupling with mechanical fault exclusion

The mounting variant described in this chapter refers to removal of the product fastened by means of front-end shaft coupling with mechanical fault exclusion.

An overview of the mounting variants is provided on Page 26.

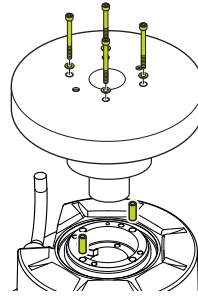

### 6.4.1 Materials and tools

For this task, the following materials and tools are needed:

#### Included in delivery

#### To be provided separately

- 2 screws (ISO 4762–M3×(Z+10))
- Torque wrench (hexagon socket, 2.5 mm and 3 mm)
- Pliers (optional)

### 6.4.2 Removing the encoder

- ▶ Disengage the connecting element
- ▶ Loosen the cable fastening
- ▶ Loosen the screws on the mounting element **(A)** and remove them including the washers

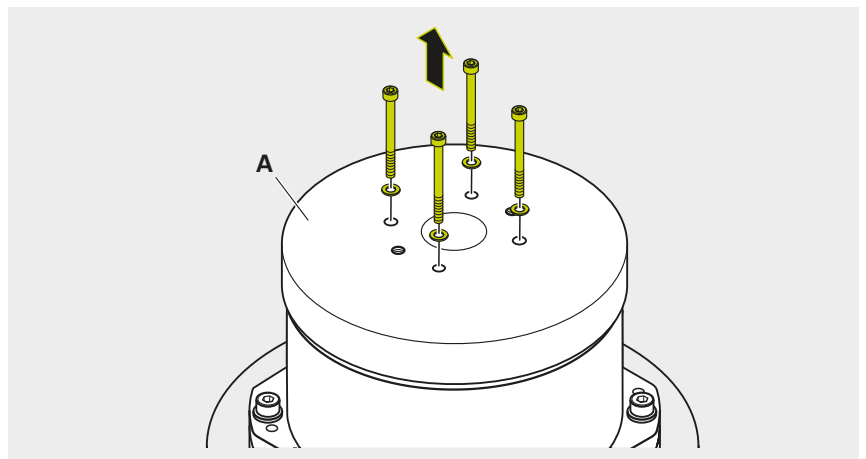

- ▶ Determine the reference dimension (**Z**) through the back-off thread (**M3**)
- ▶ Insert the screws into the two back-off threads of the mounting element
- ▶ Carefully turn in the screws until they touch the encoder

### NOTICE

#### Damage due to improper removal of the mounting element

Improper removal can lead to jamming of the mounting element, thus causing damage to the encoder.

- ▶ Tighten the screws only alternately by half a turn at a time
  - ▶ Ensure that the mounting element does not get jammed in the encoder
- 
- ▶ Tighten the screws alternately by half a turn at a time until the mounting element has loosened
  - ▶ Remove the mounting element
  - ▶ If necessary, use pliers to pull the spring pins out of the encoder
- 
- ▶ Loosen the screws and remove them including the washers
  - ▶ Remove the encoder

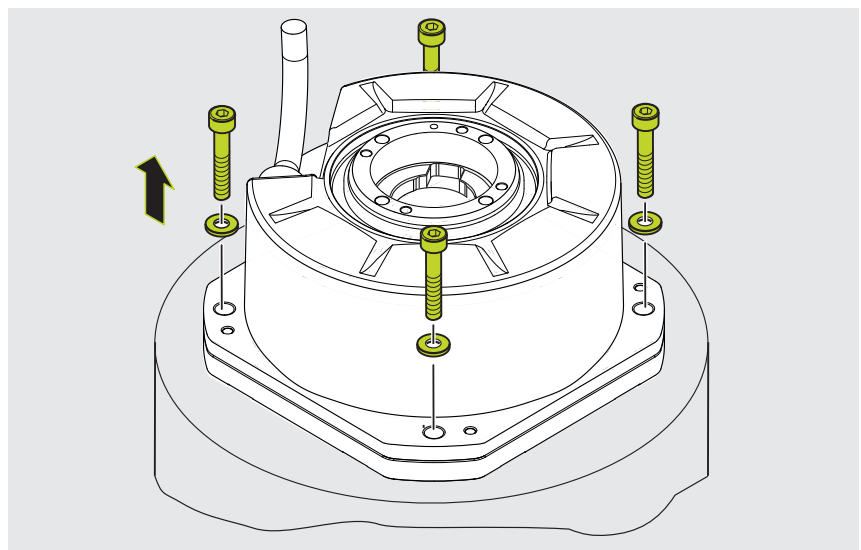
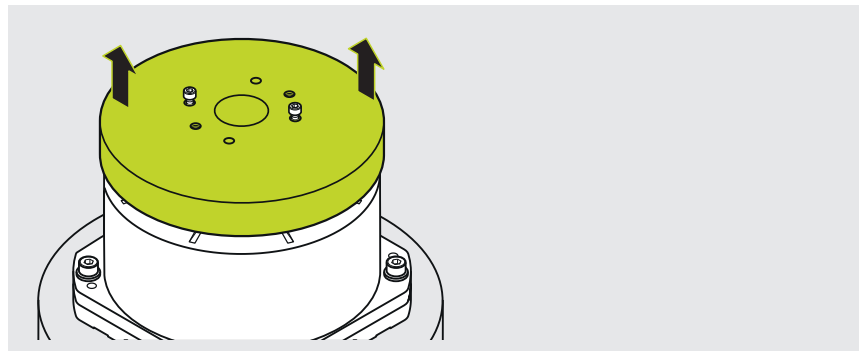
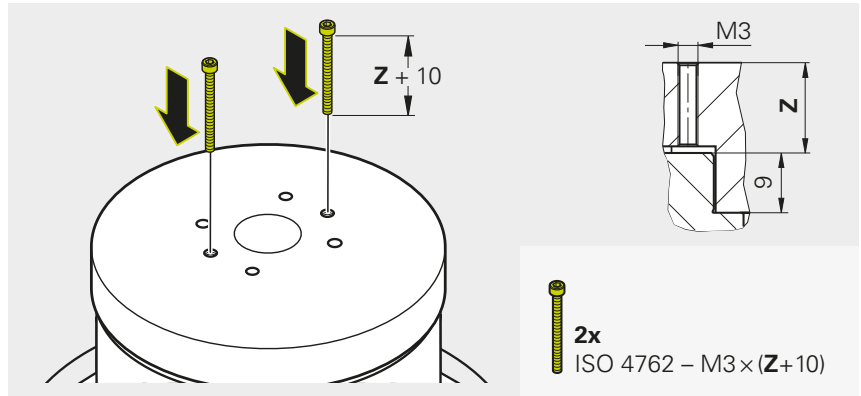

## 6.5 Mounting variant IV: front-face shaft coupling without mechanical fault exclusion

The mounting variant described in this chapter refers to removal of the product fastened by means of front-end shaft coupling without mechanical fault exclusion.

An overview of the mounting variants is provided on Page 26.

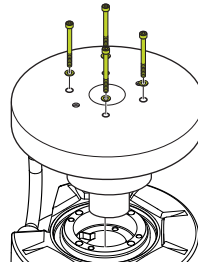

### 6.5.1 Materials and tools

For this task, the following materials and tools are needed:

#### Included in delivery

#### To be provided separately

- Torque wrench (hexagon socket, 2.5 mm and 3 mm)

### 6.5.2 Removing the encoder

- ▶ Disengage the connecting element
- ▶ Loosen the cable fastening
- ▶ Loosen the screws on the mounting element **(A)** and remove them including the washers
- ▶ Remove the mounting element

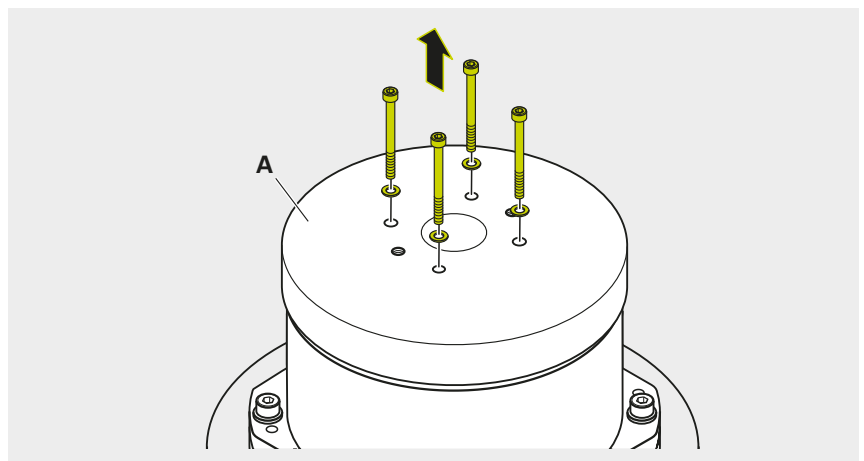

- ▶ Loosen the screws and remove them including the washers
- ▶ Remove the encoder

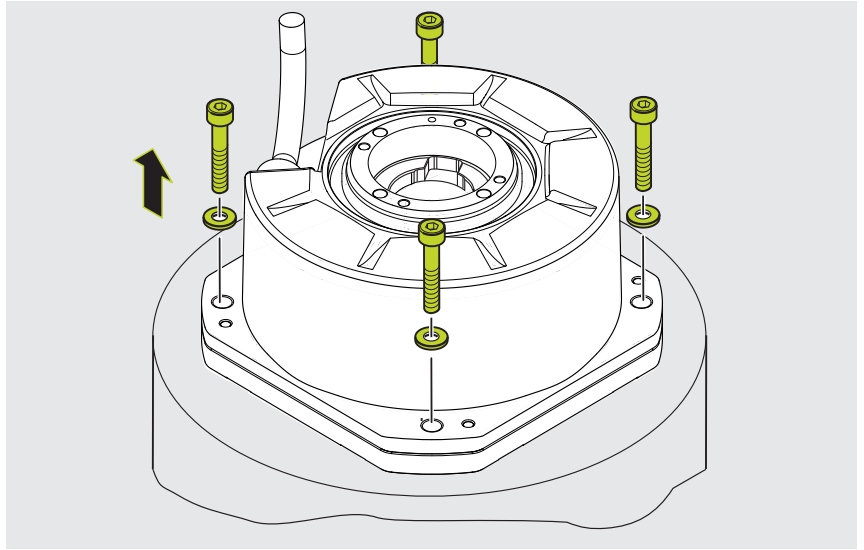

# HEIDENHAIN

## DR. JOHANNES HEIDENHAIN GmbH

Dr.-Johannes-Heidenhain-Straße 5

**83301 Traunreut, Germany**

☎ +49 8669 31-0

☎ +49 8669 32-5061

info@heidenhain.de

**Technical support** ☎ +49 8669 32-1000

**Measuring systems** ☎ +49 8669 31-3104

service.ms-support@heidenhain.de

**NC support** ☎ +49 8669 31-3101

service.nc-support@heidenhain.de

**NC programming** ☎ +49 8669 31-3103

service.nc-pgm@heidenhain.de

**PLC programming** ☎ +49 8669 31-3102

service.plc@heidenhain.de

**APP programming** ☎ +49 8669 31-3106

service.app@heidenhain.de

**www.heidenhain.com**