

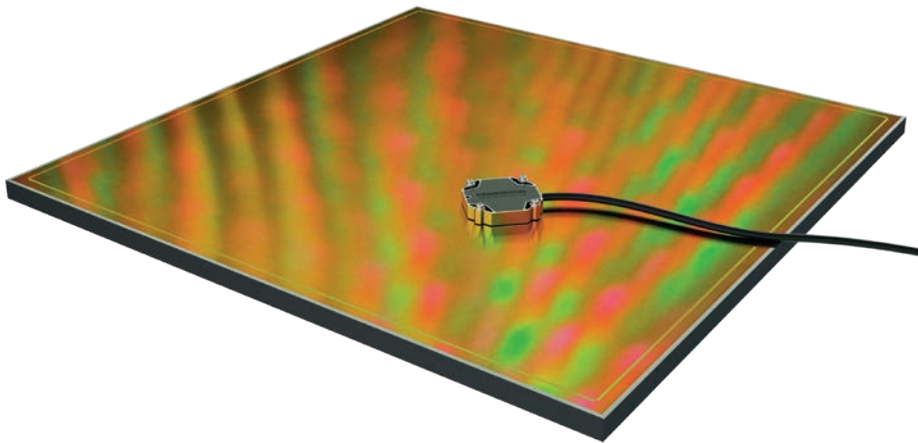

HEIDENHAIN



Product Information

PP 6000

Two-Coordinate
Incremental Encoder

PP 6000

Two-coordinate incremental encoder

- Two main directions of measurement
- Simultaneous measurement of two degrees of freedom with one scanning head
- Grid plate made of glass ceramic
- Adhesively bonded grid plate (centered thermal fixed point)

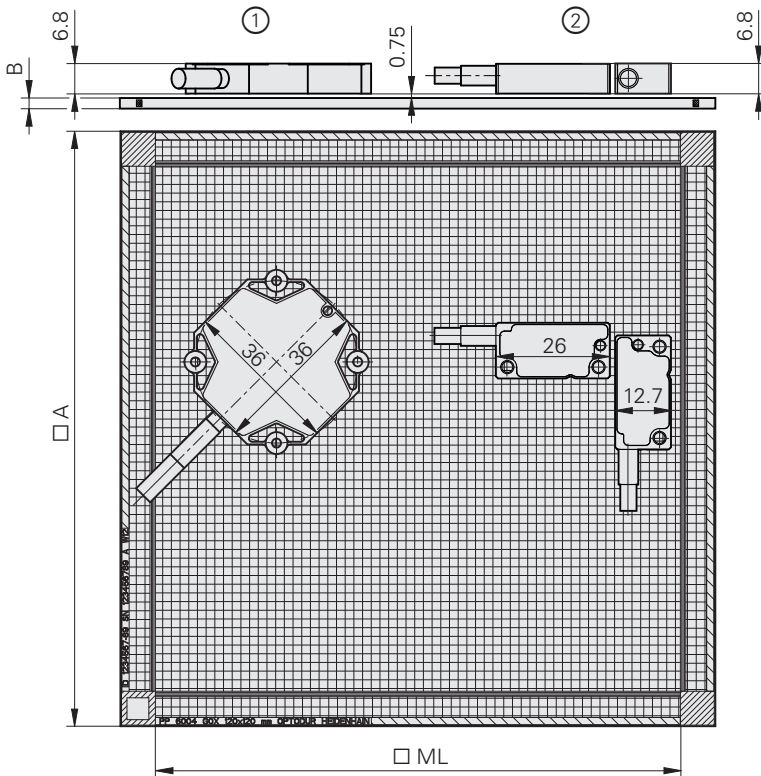
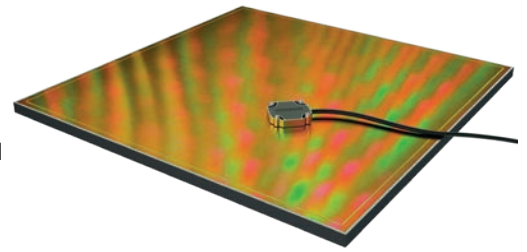

Reference mark along all edges

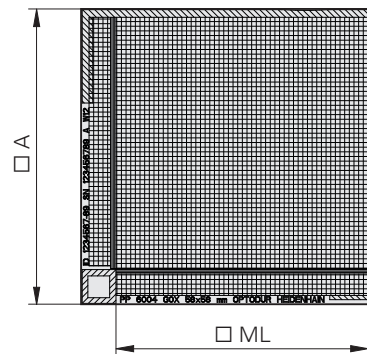

Reference along two edges

Grid plate	ML*	A	B	Reference mark
PP 6002	480 x 480	498 x 498	10	Along all edges
	237 x 237	248 x 248		Along two edges
PP 6004	120 x 120	136 x 136	2.9	Along all edges
	58 x 58	68 x 68		Along two edges

1 = AK PP 603 scanning head

2 = AK PP 608 scanning heads (multiple)

* The achievable measuring length when using multiple scanning heads depends on how they are arranged.

For technical drawings, visit: www.heidenhain.com/documentation



Mating dimensions

[ID 1411216](#)



Adhesive interface

[ID 1459013](#)

Grid plate	PP 6004 grid plate		PP 6002 grid plate	
Graduation carrier ¹⁾ Coefficient of linear expansion	OPTODUR phase grating on glass ceramic; graduation period: 8 µm $\alpha_{\text{therm}} = (0 \pm 0.5) \cdot 10^{-6} \text{ K}^{-1}$ (ML 120 x 120) $\alpha_{\text{therm}} = (0 \pm 0.1) \cdot 10^{-6} \text{ K}^{-1}$ (ML 480 x 480)			
Accuracy grade	±2 µm (measuring range: 120 x 120) ±3 µm (measuring range: 480 x 480)			
Baseline error	±0.175 µm/5 mm (not adhesively bonded) ±0.300 µm/5 mm (adhesively bonded by customer)			
Measuring range in mm*	58 x 58	120 x 120	237 x 237	480 x 480
Outer dimensions in mm	68 x 68	136 x 136	248 x 248	498 x 498
Thickness in mm	2.9		10	
Reference mark	One for each direction of measurement	Two for each direction of measurement	One for each direction of measurement	Two for each direction of measurement
Mass	130 g	540 g	1555 g	6250 g
Scanning head	AK PP 603		AK PP 608	
Interface	EnDat 3		1 V _{PP}	
Ordering designation	E30-R4		–	
Measuring step	244 pm		–	
Availability of position value	X direction: < 11 µs at 12.5 Mbit/s; < 8.2 µs at 25 Mbit/s ²⁾ Y direction: < 18.7 µs at 12,5 Mbit/s; < 12.1 µs at 25 Mbit/s ³⁾		–	
Traversing speed	≤ 240 m/min ⁴⁾			
Interpolation error	±5 nm			
RMS position noise	0.8 nm (250 kHz); 1.5 nm (1 MHz)			
Electrical connection	Cable (0.5 m/1 m/3 m) with interface electronics in the connector (15-pin D-sub (male))		Cable (0.5 m/1 m/3 m) with 15-pin D-sub connector (male) Cable (0.5 m/1 m/1.5 m/3 m) with 12-pin SHR-12V-S connector (female)	
Cable outlet	Straight		Left, right, straight, angled	
Cable length	12.5 Mbit/s: ≤ 100 m; 25 Mbit/s: ≤ 40 m During signal adjustment with the PWM 21: ≤ 3 m		With HEIDENHAIN cable ≤ 20 m During signal adjustment with the PWM 21: ≤ 3 m	
Supply voltage	DC 3.6 V to 14 V (recommended: 12 V)		DC 5 V ±0.5 V	
Power consumption ⁵⁾ (max.)	3.6 V: ≤ 1.5 W; 14 V: ≤ 1.8 W		–	
Current consumption	At 12 V: 110 mA (without load, typical)		≤ 150 mA	
Vibration 55 Hz to 2 kHz Shock 11 ms	≤ 500 m/s ² (IEC 60068-2-6) ≤ 1000 m/s ² (IEC 60068-2-27)			
Operating temperature	–10 °C to 70 °C			
Mass Scanning head APE connector Connecting cables	≈ 30 g ≈ 77 g ≈ 36 g/m		≈ 5 g ≈ 71 g ≈ 24 g/m	

* Please select when ordering

¹⁾ Other materials upon request

²⁾ This value is stored in the encoder as the parameter XEL.timeHPFout and outputs the time interval between the position-value request (latch) and the availability of the position value in the Master (without cable factors)



³⁾ With transmission in the first LPF

⁴⁾ Maximum traversing speed during crossing of the reference mark: 120 m/min

⁵⁾ See "General electrical information" in the *Interfaces of HEIDENHAIN Encoders* brochure

Pin layout

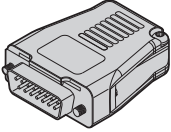
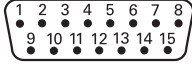
AK PP 603 scanning head

15-pin D-sub connector															
															
	Power supply				Other signals									Serial data transmission	
	4	12	2	10	1	9	3	11	14	7	13	5	6	8	15
	Up	Sensor Up	0V	Sensor 0V	Vacant	Vacant	Vacant	Vacant	Vacant	Vacant	Vacant	Vacant	Vacant	SD+	SD-
	Brown/ Green	/	White/ Green	/	/	/	/	/	/	/	/	/	/	Violet	Yellow



Shield on housing; **Up** = Power supply voltage

Sensor: The sense line is connected in the encoder with the corresponding power line.

Vacant pins or wires must not be used.

¹⁾ Color assignment of the connecting cable

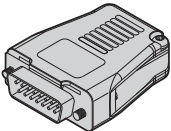
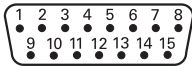
AK PP 608 scanning head

15-pin D-sub connector (male)															
															
	Power supply				Incremental signals						Serial data transmission/ Other signals				
	4	12	2	10	1	9	3	11	14	7	13	15	5	6	8
	Up	Sensor Up	0V	Sensor 0V	A+	A-	B+	B-	R+	R-	Va- cant ¹⁾	Va- cant ¹⁾	Vacant	Vacant	Vacant
	Brown/ Green	/	White/ Green	/	Brown	Green	Gray	Pink	Red	Black	Violet	Yellow	/	/	/

Shield on housing; **Up** = Power supply voltage

Sensor: The sense line is connected in the encoder with the corresponding power line.

Vacant pins or wires must not be used.

¹⁾ Required for signal adjustment with the PWM 21

HEIDENHAIN

DR. JOHANNES HEIDENHAIN GmbH

Dr.-Johannes-Heidenhain-Straße 5

83301 Traunreut, Germany

☎ +49 8669 31-0

☎ +49 8669 32-5061

✉ info@heidenhain.de

www.heidenhain.com

This Product Information document supersedes all previous editions, which thereby become invalid. The basis for ordering from HEIDENHAIN is always the Product Information document edition valid when the order is placed.



More information:

Comply with the requirements described in the following documents to ensure correct and intended operation:

- Brochure: *Cables and Connectors*
- Brochure: *Interfaces of HEIDENHAIN Encoders*

[1206103-xx](#)

[1078628-xx](#)