

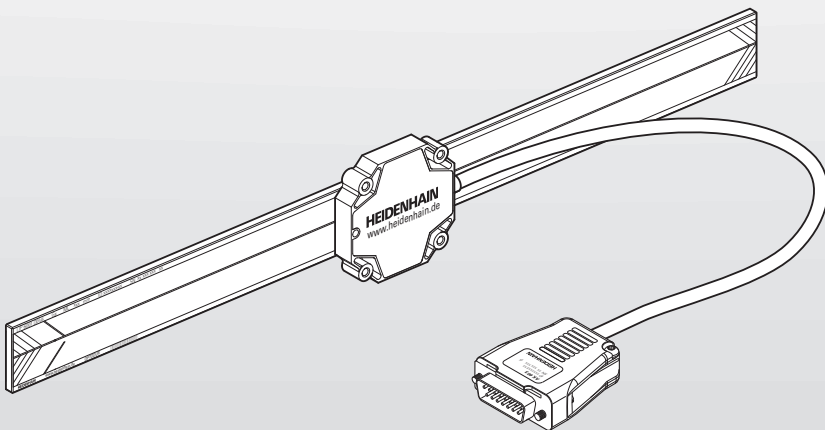

HEIDENHAIN



LIP 6031 Dplus

Mounting Instructions

Contents

1	Basic information.....	5
2	Safety.....	9
3	Items supplied and accessories.....	11
4	Mounting.....	14
5	Adjustment and diagnosis.....	23
6	Removal.....	36

1	Basic information.....	5
1.1	Validity of the documentation.....	5
1.2	Target groups of the Mounting Instructions.....	5
1.3	Notes on reading the documentation.....	6
1.4	Symbols and fonts used for marking text.....	7
1.5	Notes in this documentation.....	8
1.6	Units and tolerances.....	8
2	Safety.....	9
2.1	Personnel qualification.....	9
2.2	General safety precautions.....	9
3	Items supplied and accessories.....	11
3.1	Items supplied.....	11
3.1.1	Items supplied with the linear scale.....	11
3.1.2	Items supplied with the scanning head.....	12
3.2	Mounting accessories.....	13
3.2.1	For mounting the linear scale.....	13
3.2.2	Accessories for fixed-point bonding.....	13
4	Mounting.....	14
4.1	Prerequisites and notes.....	14
4.2	Mounting the linear scale.....	15
4.2.1	Notes on mounting the linear scale.....	15
4.2.2	Materials and tools.....	16
4.2.3	Gluing the linear scale.....	17
4.2.4	Mounting the fixed-point elements.....	18
4.3	Mounting the scanning head.....	19
4.3.1	Notes on mounting the scanning head.....	19

4.3.2	Materials and tools.....	19
4.3.3	Mounting the scanning head.....	19
4.4	Final steps.....	21
4.4.1	Performing the continuity check.....	21
4.4.2	Connecting the encoder.....	22
5	Adjustment and diagnosis.....	23
5.1	Connecting an encoder using its ID.....	23
5.2	Connecting the encoder manually.....	24
5.3	Using the mounting wizard.....	26
5.4	Checking the mounting.....	32
5.5	Activating/Deactivating the function display.....	33
6	Removal.....	36
6.1	Safety precautions regarding removal.....	36
6.2	Removing the scanning head.....	36
6.3	Removing the scale.....	36

1 Basic information

This chapter contains information about the product and the Mounting Instructions.

1.1 Validity of the documentation

These Mounting Instructions apply to encoders of the LIP 6031 Dplus series.

- ▶ Prior to using the documentation, check whether the documentation and encoder model match
- The encoder designation is printed on the ID label.

ID label

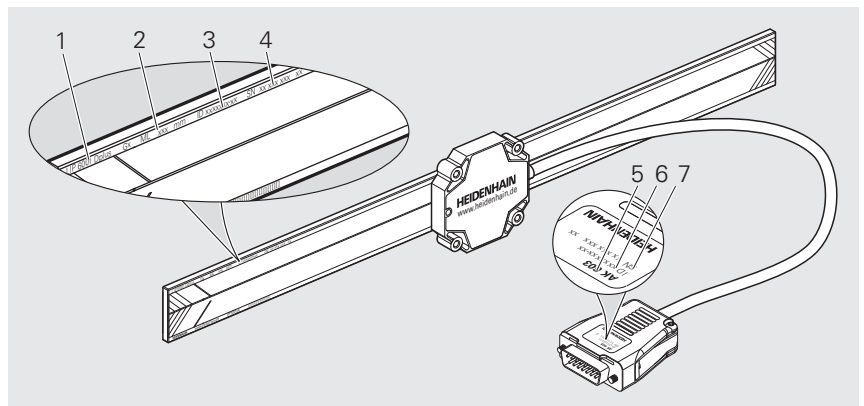

ID label with legend

- 1 Product name of scale
- 2 Measuring length (ML)
- 3 Part number (ID) of scale
- 4 Serial number (SN) of scale
- 5 Product name of scanning head
- 6 ID number of scanning head
- 7 Serial number of scanning head

1.2 Target groups of the Mounting Instructions

The Mounting Instructions must be read and observed by every person who performs any of the following tasks:

- Design
- Mounting
- Removal

1.3 Notes on reading the documentation

WARNING

Fatal accidents, personal injury or property damage caused by non-compliance with the documentation!

Failure to comply with the documentation may result in fatal accidents, personal injury or property damage.

- ▶ Read the documentation carefully from beginning to end
- ▶ Keep the documentation for future reference

The following table lists the various parts of the documentation in their order of reading priority.

Document type	Description
Addendum	An addendum supplements or supersedes the corresponding contents of the Operating Instructions and, if applicable, of the Mounting Instructions. If an addendum is included in the shipment, it has the highest priority for reading. All other documentation content retains its validity.
Operating Instructions	The Operating Instructions contain all of the information and safety instructions for the proper and intended operation of the device. The Operating Instructions (English language version) are included in delivery and can also be downloaded in other languages from www.heidenhain.com/documentation . The Operating Instructions must be read prior to commissioning the product. The Operating Instructions have the second highest priority for reading.
Mounting Instructions	The Mounting Instructions contain all the information and safety precautions needed for the proper mounting and installation of a product. The Mounting Instructions are not included in delivery and must be downloaded from www.heidenhain.com/documentation . The Mounting Instructions have the third highest priority for reading.

Have you found any errors or would you like to suggest changes?

We are continuously striving to improve our documentation for you. Please help us by sending your suggestions to the following e-mail address:

userdoc@heidenhain.de

1.4 Symbols and fonts used for marking text

In these instructions the following symbols and fonts are used for marking text:

Format	Meaning
▶ ... > ...	Identifies an action and the result of this action Example: ▶ Tilt the shipping brace to remove it (c) > The shipping brace has been removed now
■ ... ■ ...	Identifies an item of a list Example: ■ Solid contaminants: class 3 ■ Max. pressure dew point: class 4
Bold	Identifies elements in figures and illustrations, such as positions, dimensions and worksteps Example: S marks the beginning of the measuring length (ML) .

1.5 Notes in this documentation

Safety precautions

Precautionary statements warn of hazards in handling the device and provide information on their prevention. Precautionary statements are classified by hazard severity and divided into the following groups:

DANGER

Danger indicates hazards for persons. If you do not follow the avoidance instructions, the hazard **will result in death or severe injury**.

WARNING

Warning indicates hazards for persons. If you do not follow the avoidance instructions, the hazard **could result in death or serious injury**.

CAUTION

Caution indicates hazards for persons. If you do not follow the avoidance instructions, the hazard **could result in minor or moderate injury**.

NOTICE

Notice indicates danger to material or data. If you do not follow the avoidance instructions, the hazard **could result in property damage**.

Informational notes

Informational notes ensure reliable and efficient operation of the device. Informational notes are divided into the following groups:



The information symbol indicates a **tip**.
A tip provides important additional or supplementary information.



The book symbol indicates a **cross reference**.
A cross reference leads to external documentation, for example: further documentation from HEIDENHAIN or another supplier.

1.6 Units and tolerances

Unless otherwise specified, the dimensions stated in these Mounting Instructions are given in millimeters.

Unless otherwise specified, the tolerances stated in these Mounting Instructions correspond to ISO 8015 and ISO 2768 standards.

mm

 Tolerancing ISO 8015
 ISO 2768:1989-mH
 $\leq 6 \text{ mm: } \pm 0.2 \text{ mm}$

2 Safety

This chapter provides important safety information needed for the proper mounting and installation of the product.

2.1 Personnel qualification

Mounting, initial configuration and removal must be conducted by a qualified specialist under compliance with local safety regulations.

2.2 General safety precautions

WARNING

Danger of electric shock due to connection to unsuitable downstream electronics!

If you connect unsuitable downstream electronics to the encoder, fatal accidents or severe personal injuries can occur.

- ▶ Connect the encoder only to downstream electronics whose supply voltage comes from PELV systems

WARNING

Live plug connections

If you disengage plug connections while the equipment is under power, this may result in fatal accidents or severe personal injury.

- ▶ Do not engage or disengage any connecting elements while the product is under power

WARNING

Risk of injury from damaged or worn components!

Safety functions can fail if damaged or worn components are installed. Failed safety functions can result in death or serious injury.

- ▶ Do not use any damaged or worn components
- ▶ In case of replacement, repair the thread
- ▶ In case of replacement, use new screws, spring pins and nuts
- ▶ Secure screws and nuts with suitable material-bonding anti-rotation lock

NOTICE

Property damage due to mechanical stress

- ▶ Do not drop the encoder or subject it to major vibration
- ▶ Do not expose the encoder to mechanical stress

NOTICE

Property damage due to electrical stress

- ▶ Do not engage or disengage any connecting elements while the product is under power
- ▶ Do not touch the contacts of the plug connections

NOTICE**Electrostatic discharge (ESD)!**

This device contains electrostatic-sensitive components that can be destroyed by electrostatic discharge (ESD).



- ▶ It is essential to observe the safety precautions for handling ESD-sensitive components
- ▶ Never touch connector pins without ensuring proper grounding
- ▶ Wear a grounded ESD wristband when handling device connections

3 Items supplied and accessories

This chapter contains information on the items supplied and the available accessories of the encoder.

3.1 Items supplied

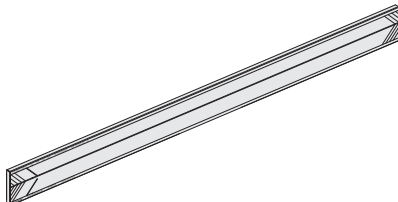
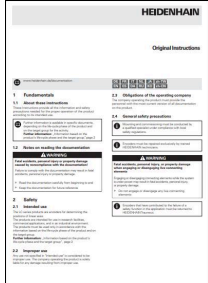
3.1.1 Items supplied with the linear scale

Component	Figure
Scale with adhesive film	
Operating Instructions	
Quality Inspection Document	

3.1.2 Items supplied with the scanning head

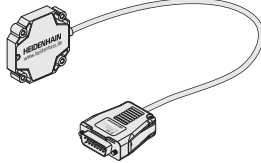
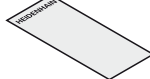
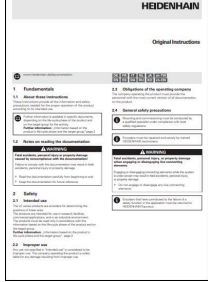
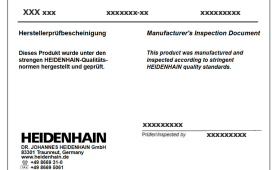
Component	Figure
Scanning head	
Spacer shim	
Operating Instructions	
Manufacturer's Inspection Document	

3.2 Mounting accessories

The following accessories can be obtained separately from HEIDENHAIN.



For more information on the listed products, please refer to the applicable Mounting Instructions and the **Exposed Linear Encoders** brochure.

- ▶ www.heidenhain.com/documentation
- ▶ Enter the document ID **208960**

3.2.1 For mounting the linear scale

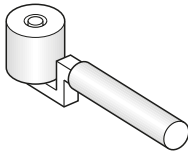
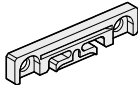
Designation	ID	Figure
Roller	276885-01	
Fixed-point elements	1176475-xx	

3.2.2 Accessories for fixed-point bonding

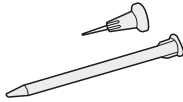
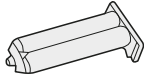
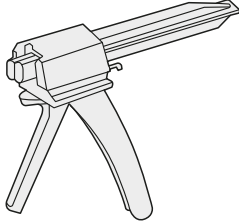
Designation	ID	Figure
Dispensing nozzles and mixing tubes	1176444-01	
Adhesive 3M DP 460 EG	1180444-01	
Double-cartridge gun	1180450-01	

4 Mounting

This chapter describes the mounting prerequisites, different mounting variants, and all other tasks necessary when mounting.

4.1 Prerequisites and notes

Choose a mounting attitude such that the traverse range is within the measuring length (**ML**) of the encoder.

Protect the graduation from direct contamination.

(**S**) = Beginning of measuring length (**ML**)

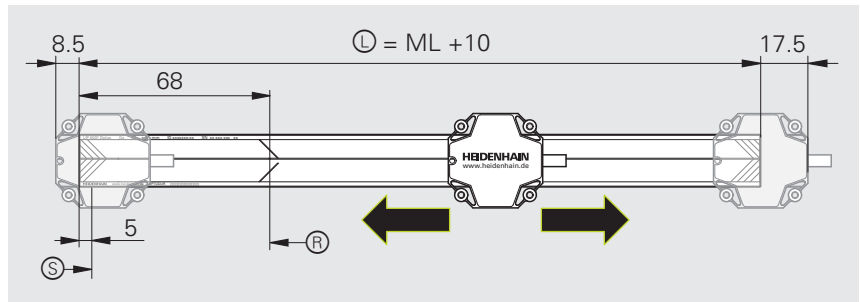

NOTICE

Property damage resulting from severe contamination or liquids

The encoder is not protected against the ingress of severe contamination or liquids, and an electrical short-circuit can occur.

- ▶ If necessary, protect the encoder by attaching a protective plate or something similar

In order to avoid signal interferences, ensure correct positioning of the scale to the scanning head.

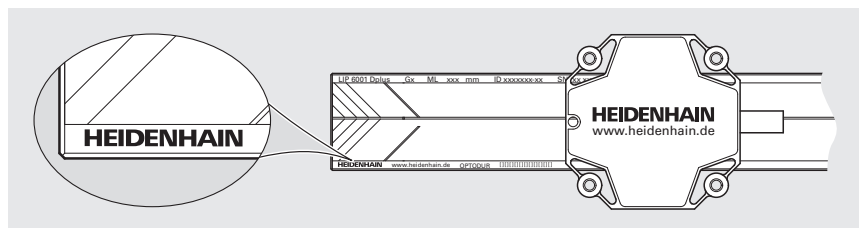

In order to avoid signal interferences, observe the minimum clearance from sources of interference.



For more information on sources of interference, refer to the **Interfaces of HEIDENHAIN Encoders** brochure.

- ▶ www.heidenhain.com/documentation
- ▶ Enter the document ID **1078628**

4.2 Mounting the linear scale

4.2.1 Notes on mounting the linear scale

Note that the mounting surface, as well as the surface of the scale, must be clean and free of paint, dust or grease.

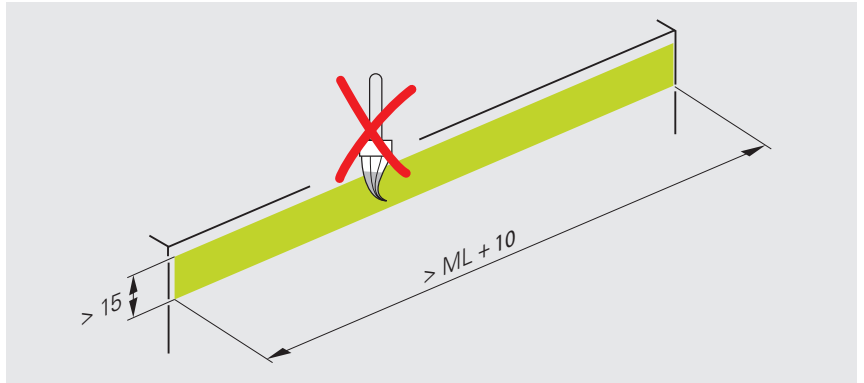

You can mount the scale by means of stop pins or an aligning rail.

The mounting tolerances refer to the machine guideway (**F**).



Number of stop pins to be used

Recommended diameter of the stop pins: 3 mm.

For a measuring length of **ML ≤ 2040**, use three stop pins to stabilize the scale sufficiently.

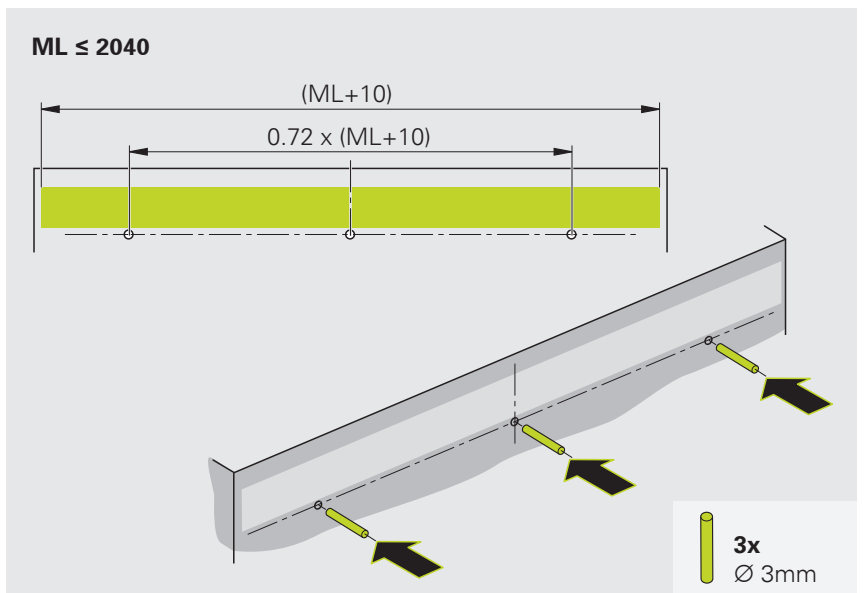

For a measuring length of **ML > 2040**, use five stop pins to stabilize the scale sufficiently.

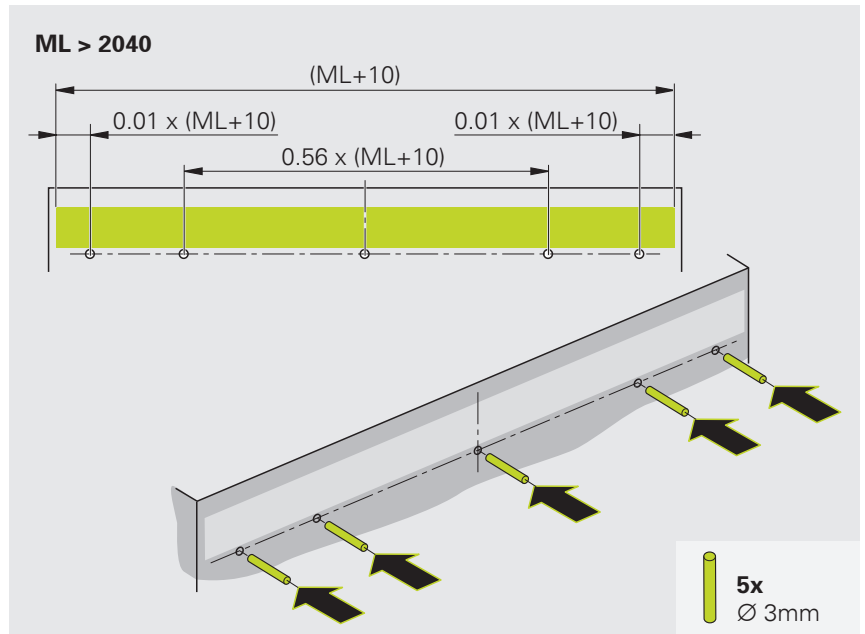

4.2.2 Materials and tools

For this task, the following materials and tools are needed:

Included in delivery

To be provided separately

- Roller
- Stop pins
- Fixed-point elements
- Adhesive
- 4 screws (DIN 7984 – M3x6)
- Torque wrench (hexagon socket for 2.5 mm)

4.2.3 Gluing the linear scale

Attach the scale with adhesive mounting film only at a temperature of $> 15\text{ °C}$.

Pay attention to the expiration date on the package.

- ▶ Insert the stop pins
- ▶ Remove the protective foil from the adhesive film

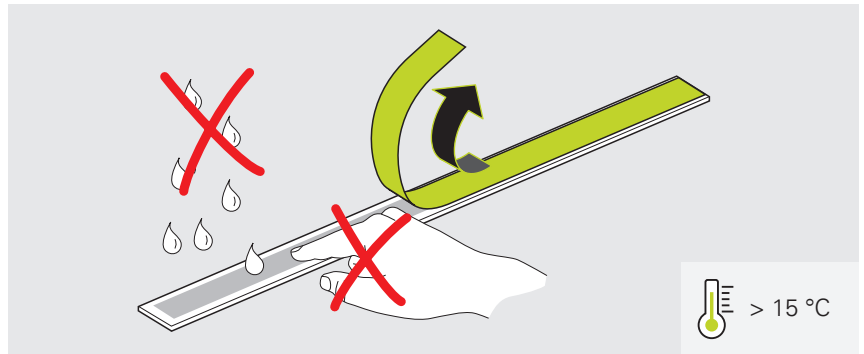

- ▶ Carefully place the scale onto the stop pins
- ▶ Starting from the center, evenly press the scale onto the mounting surface using the roller
- ▶ Remove the stop pins

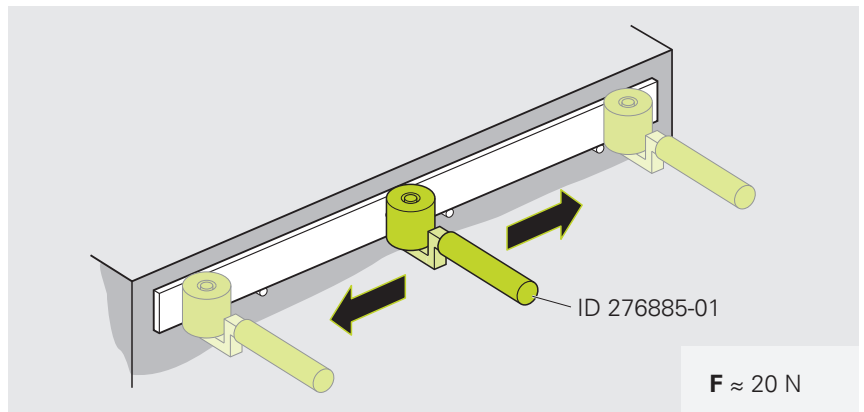

- ▶ Do not perform further work on the scale until the maximum adhesive force has been reached



The maximum adhesive force of the mounting film is reached at room temperature after approx. 70 hours.

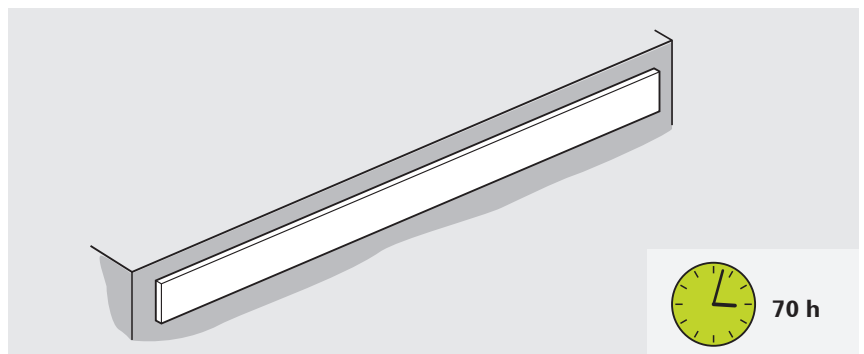

4.2.4 Mounting the fixed-point elements

Pay attention to the mounting dimensions. Deviations from the mounting dimensions lead to imprecise measurement results during operation.

- ▶ Align the fixed-point elements in parallel
- ▶ Lightly press the fixed-point elements against the scale and fasten them with screws using the prescribed torque

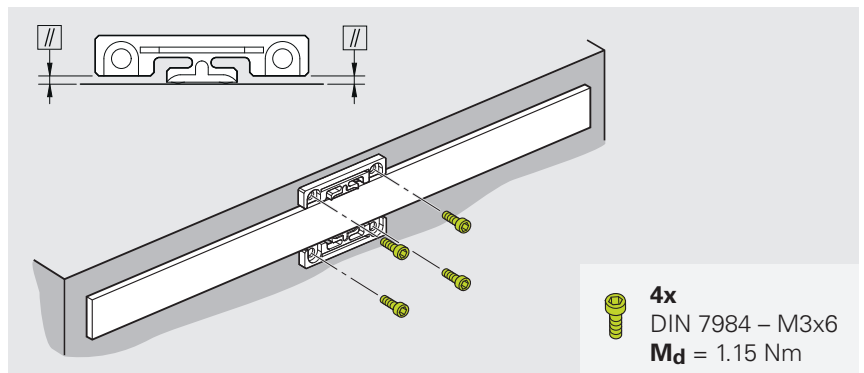
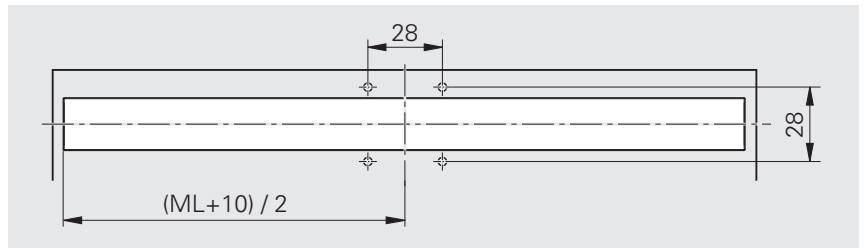

i Pay attention to the work instructions in the applicable documentation.

- ▶ Apply a bead of adhesive with a double cartridge gun and a dispensing nozzle.
- ▶ Allow the adhesive to harden as appropriate for the intended operating temperature
- ▶ Do not add more adhesive

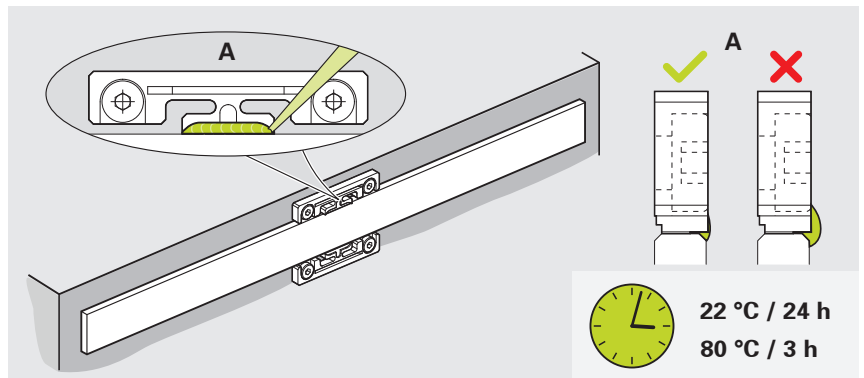

i To ensure high fixed-point rigidity, pay attention to the specifications for curing temperature and curing time.

Operating temperature	Curing temperature	Curing time
-10 °C to +30 °C	22 °C	24 hours
-10 °C to +70 °C	80 °C	3 hours

4.3 Mounting the scanning head

4.3.1 Notes on mounting the scanning head

i If necessary, clean the graduation and the scanning head with a lint-free cloth and isopropyl alcohol.

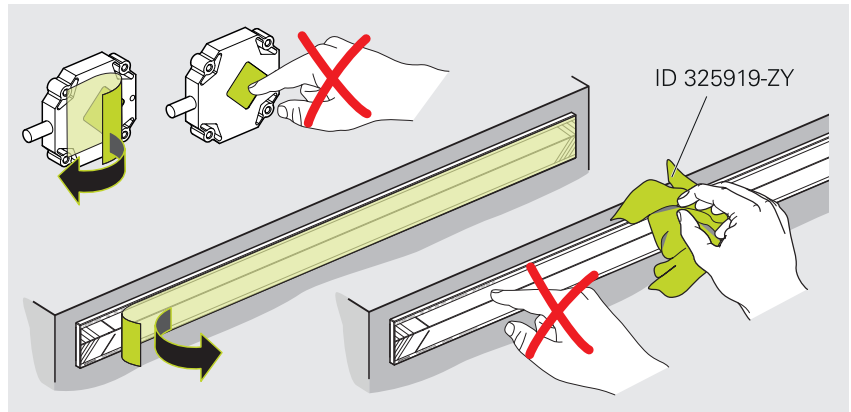

4.3.2 Materials and tools

For this task, the following materials and tools are needed:

Included in delivery

- Spacer shim

To be provided separately

- 4 screws (ISO 4762 – M2.5×(a+6) – 8.8)
- 4 washers (ISO 7092 – 2.7)
- 1 alignment pin (2m6)
- Torque wrench (hexagon socket for 2 mm)

4.3.3 Mounting the scanning head

- ▶ Use the spacer shim to set the mounting clearance
- ▶ Lightly screw on the scanning head
- ▶ Remove the spacer shim

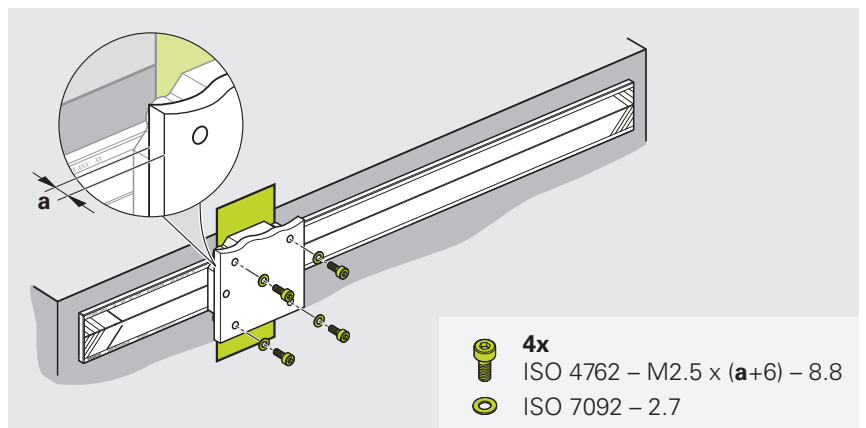

- ▶ Insert the dowel pin

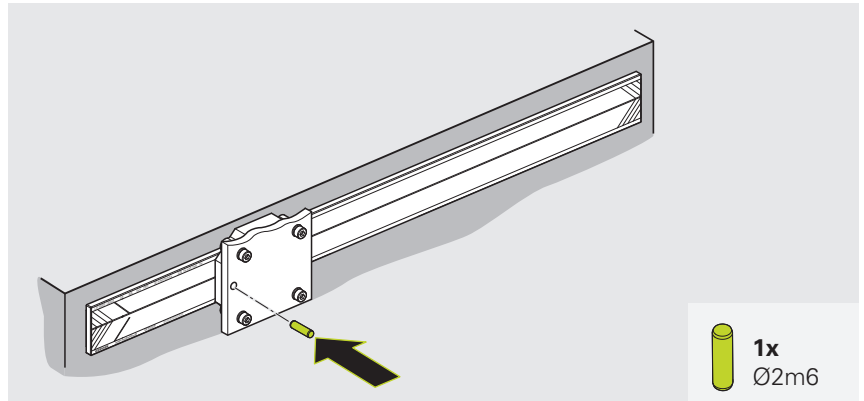

- ▶ Optimize the signals

Further information: "Adjustment and diagnosis", Page 23

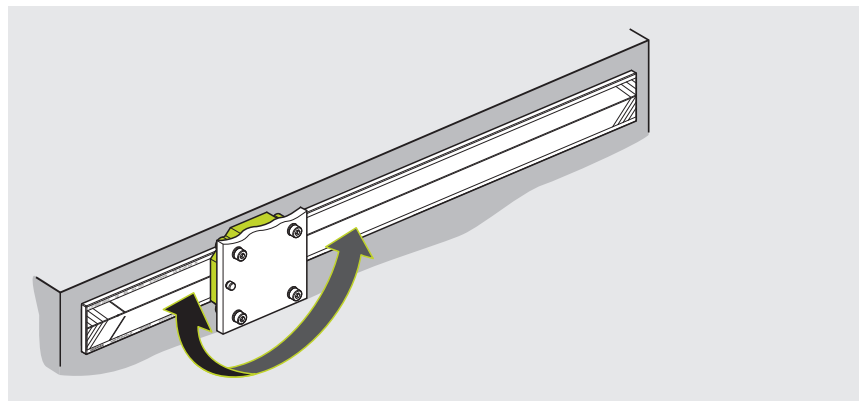

- ▶ Tighten the screws with the specified torque

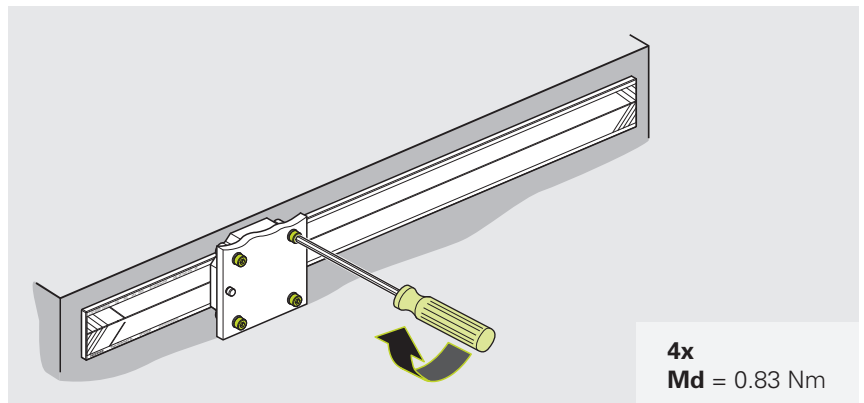

- ▶ Remove the dowel pin

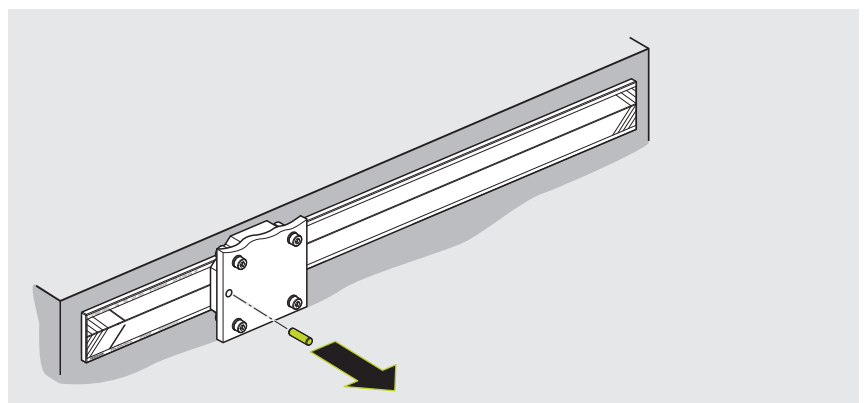

4.4 Final steps

4.4.1 Performing the continuity check

Materials and tools

For this mounting step, the following materials and tools are needed:

Included in delivery

To be provided separately

- Resistance measuring device

Measuring the resistance

- ▶ Check the resistance between the connector housing and the machine



The resistance between the connector housing and the machine must be $< 1 \Omega$.

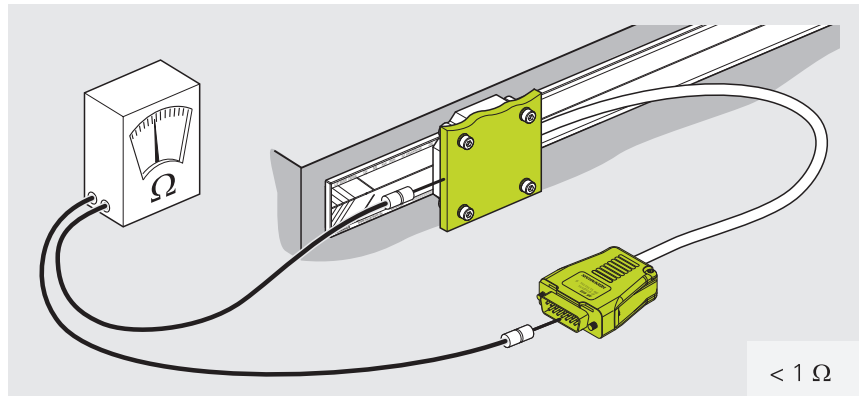

Resistance measurement

- ▶ If necessary, connect the shield with the machine earth (field ground)

4.4.2 Connecting the encoder

⚠ WARNING

Danger of electric shock due to plug connections under voltage

Connecting and disconnecting live cables and plug connections in the equipment can result in death or serious injury.

- Only connect and disconnect cables and plug connections when no current is flowing through them
- Disconnect the downstream electronics from power before connecting the encoder
- For cables without connectors, pay attention to the pin layout

- ▶ Connect the encoder to the downstream electronics

NOTICE

Property damage resulting from incorrect routing of the connecting cable

Connecting cables may become damaged as a result of incorrect routing.

- ▶ Observe the maximum permissible bend radii
- ▶ Do not cross connecting cables in drag chains
- ▶ Route connecting cables professionally



For more information on the cable characteristics and cable routing, refer to the **Cables and Connectors** brochure.

- ▶ www.heidenhain.com/documentation
- ▶ Enter the document ID **1206103**



For more information on the pin layouts, refer to the **Cables and Connectors** brochure.

- ▶ www.heidenhain.com/documentation
- ▶ Enter the document ID **1206103**



For more information on sources of interference, refer to the **Interfaces of HEIDENHAIN Encoders** brochure.

- ▶ www.heidenhain.com/documentation
- ▶ Enter the document ID **1078628**

5 Adjustment and diagnosis

This chapter describes how adjustment and diagnosis are performed using the PWM 21 and the Adjusting and Testing Software (ATS).

The PWM 21 phase angle measuring unit together with the ATS software serves for the diagnosis and adjustment of HEIDENHAIN encoders.

It consists of the following components:

- PWM 21
- ATS software, version 3.6, with integrated local encoder database for automatic encoder identification.

The ATS software is available for download free of charge from the www.heidenhain.com/service/downloads/software/ area on the HEIDENHAIN website.



For more information, see the **Exposed Linear Encoders** brochure.

- ▶ www.heidenhain.com/documentation
- ▶ Enter the document ID **208960**



For more information, see the associated Adjusting and Testing Software documentation.

- ▶ www.heidenhain.com/documentation
- ▶ Enter the document ID **543734**



You can adjust and perform diagnostics on the encoder with default settings or with user-defined settings. For information about adjustment and diagnostics with default settings, see "Connecting an encoder using its ID", Page 23. For information about adjustment and diagnostics with user-defined settings, see "Connecting the encoder manually", Page 24.

5.1 Connecting an encoder using its ID

- ▶ Double-click **Connect the encoder** in the function menu
- > The Adjusting and Testing Software displays the **Encoder selection** dialog.

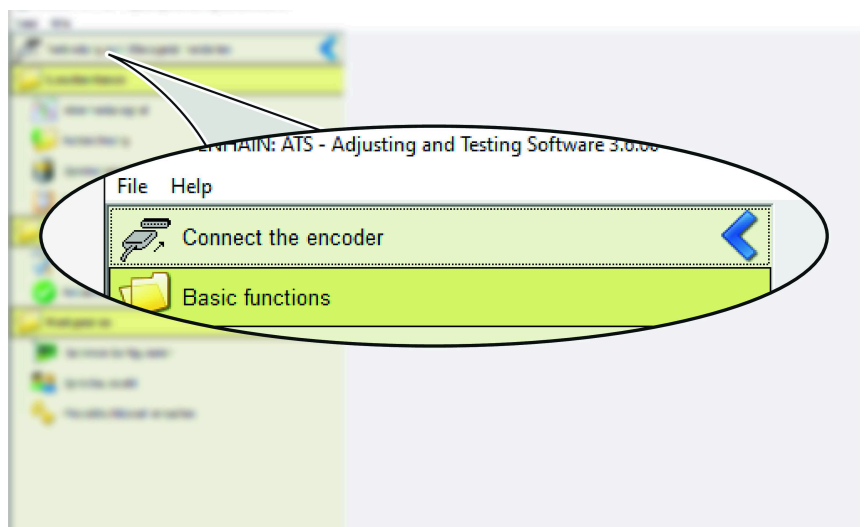

Function menu

- ▶ Enter the encoder ID in the **ID number** field
- > The determined encoder parameters are shown in the **Encoder data** field.
- ▶ Click **Connect**
- > The connection to the encoder is established.
- > The **Function menu** is displayed.

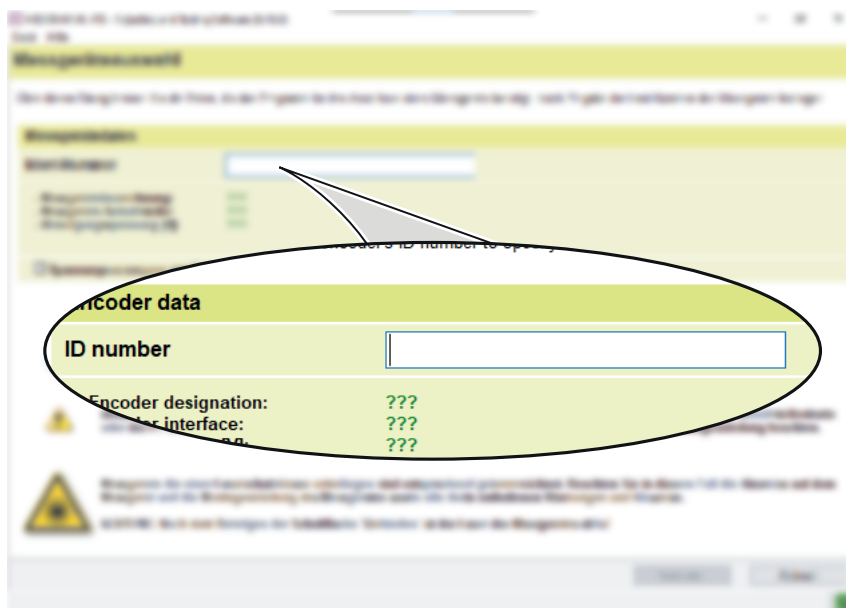

Encoder selection dialog



If you cannot connect the encoder using its ID, proceed as described in the "**Connecting the encoder manually**" chapter.

5.2 Connecting the encoder manually

- ▶ Double-click **Connect the encoder** in the function menu
- > The Adjusting and Testing Software displays the **Encoder selection** dialog.

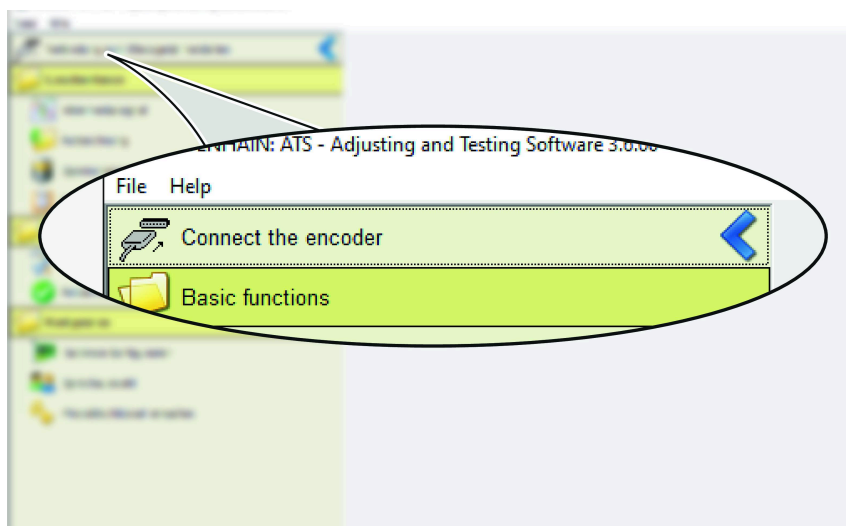

Function menu

- ▶ Click **Manual Settings**
- ▶ The Adjusting and Testing Software displays the **Encoder selection** dialog.

Encoder selection

Using this dialog you can enter an encoder's ID number to specify the data required by the program in order to connect the encoder.

Encoder data

ID number	680600-20
- Encoder designation:	???
- Encoder interface:	???
- Supply voltage [V]:	???

Use power supply from subsequent electronics

If the encoder is not listed in the encoder database or if you don't know the encoder's ID number, you can click [Manual Settings](#) here and enter the encoder parameters manually.

If the encoder is not listed in the encoder database or if you don't know the encoder's ID number, you can click [Manual Settings](#) here and enter the encoder parameters manually. For your own safety, please read the mounting instructions.

you can click [Manual Settings](#) here and

Encoders subject to a laser safety class are correspondingly identified. In this case please note the information on the encoder and all information and warnings in the encoder's mounting instructions.

CAUTION: The laser is active once the 'Connect' button has been pressed!

Encoder selection dialog

- ▶ Follow the safety instructions
- ▶ Click **Next**
- ▶ The Adjusting and Testing Software displays the **Encoder selection** dialog.

Encoder selection

Using this dialog you can manually set the data required by the program in order to connect an encoder. Please set the data manually only if the encoder is not listed in the encoder database and you know all the encoder parameters that will be requested.

This program only supports the encoder models from HEIDENHAIN that can be selected on the next page. Encoders from other manufacturers are not supported.

Entry of incorrect data might damage the encoder, the interface card, or the PC. If you do not know the parameters of the encoder, please contact HEIDENHAIN in advance.

Encoders subject to a laser safety class are correspondingly identified. In this case please note the information on the encoder and all information and warnings in the encoder's mounting instructions.

CAUTION: The laser is active once the 'Connect' button has been pressed!

Encoder selection dialog



For more information on the supply voltage and interfaces, refer to the **Exposed Linear Encoders** brochure.

- ▶ www.heidenhain.com/documentation
- ▶ Enter the document ID **208960**

- ▶ Select the permissible encoder supply voltage in the **Encoder supply voltage** section
- ▶ To activate voltage readjustment by the PWM, check the box **Adjust voltage over sensor lines**
- ▶ Select the EnDat 3 interface type
- ▶ Click **Connect**
- ▶ The **Function menu** appears.

Encoder selection

All data for connecting the encoder have now been entered. Before connecting the encoder to the interface card and establishing the connection to the encoder via the "Connect" button, check all data shown under "Encoder data."

Encoder data

- Encoder interface:	1 Vpp
- Supply voltage [V]:	5.0
- Adjust voltage:	No
- ATS code:	I004.A003

 Entry of incorrect data might damage the encoder, the interface card, or the PC.

 Encoders subject to a laser safety class are correspondingly identified. In this case please note the information on the encoder and all information and warnings in the encoder's mounting instructions.
CAUTION: The laser is active once the 'Connect' button has been pressed!

The **Encoder selection** dialog with the encoder data

5.3 Using the mounting wizard

 The function display is inactive as long as the **LIP mounting verification** tab is open.

- ▶ Click the **Wizards** tab

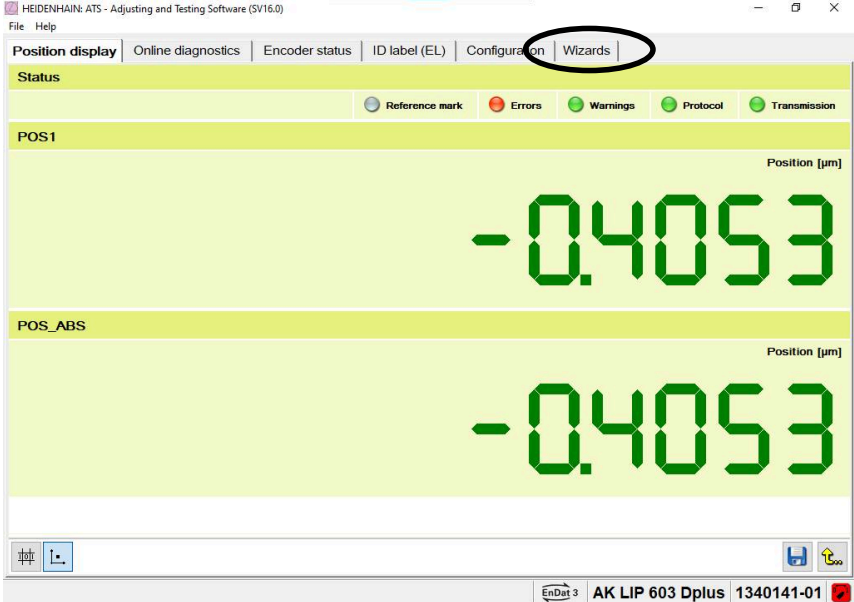

HEIDENHAIN: ATS - Adjusting and Testing Software (SV16.0)

File Help

Position display | Online diagnostics | Encoder status | ID label (EL) | Configuration | **Wizards**

Status

Reference mark Errors Warnings Protocol Transmission

POS1 Position [μm]

-0.4053

POS_ABS Position [μm]

-0.4053

EnDat 3 AK LIP 603 Dplus 1340141-01

Position display tab

- > The **Wizards** selection is displayed.

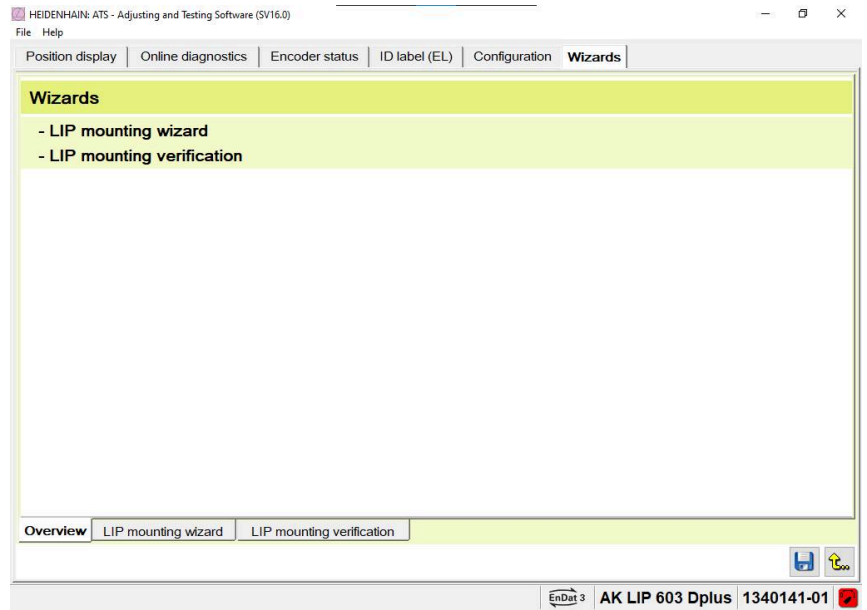

Wizards tab

- ▶ Click the **LIP mounting wizard** tab on the bottom
- > The message **Step 1: Note** is displayed.

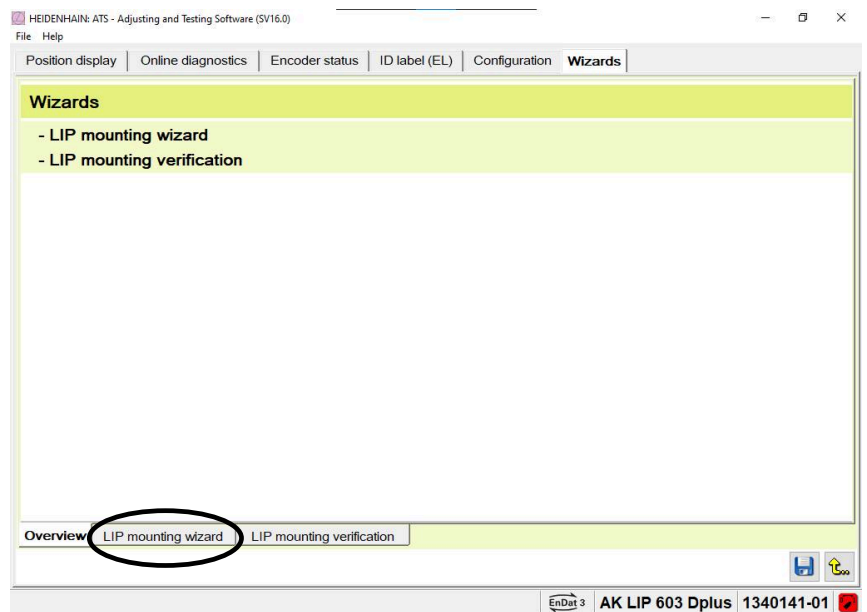

Wizards selection

- ▶ Click **Next >**
- ▶ The message **Step 2: Mounting the encoder** appears.

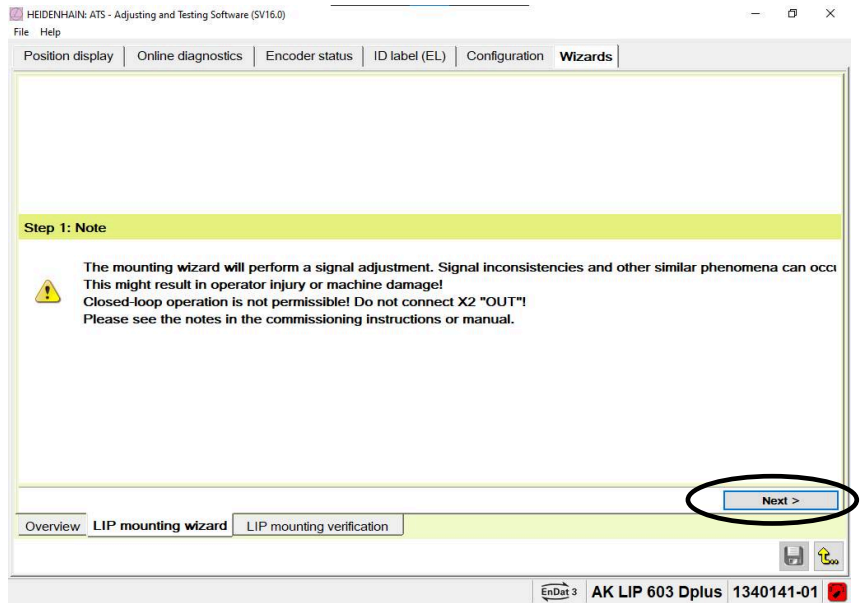

Wizards tab with **Step 1: Note** message

- ▶ Click **Next**
- ▶ The message **The encoder will be reset to its factory settings** is displayed.

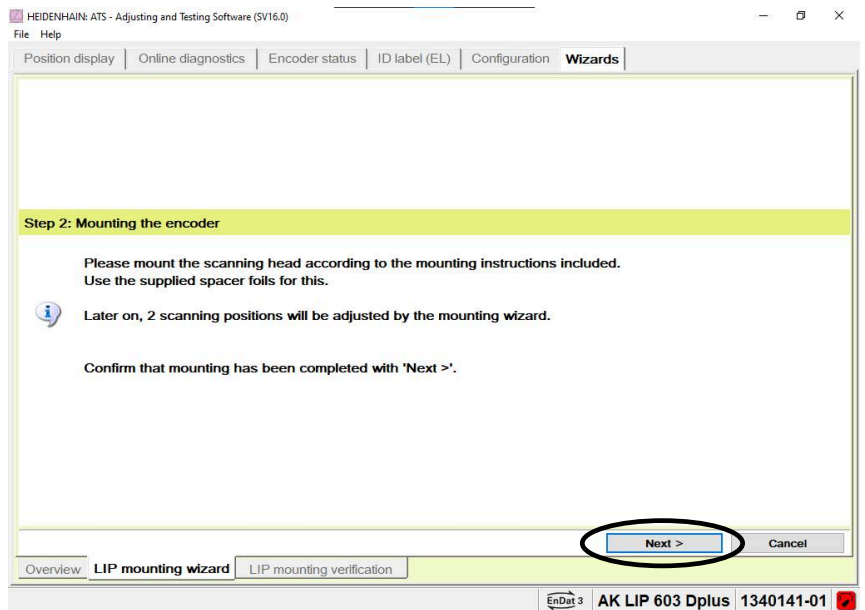

Wizards tab with **Step 2: Mounting the encoder** message

- ▶ Click **OK**
- ▶ The encoder is reset to the factory default settings.

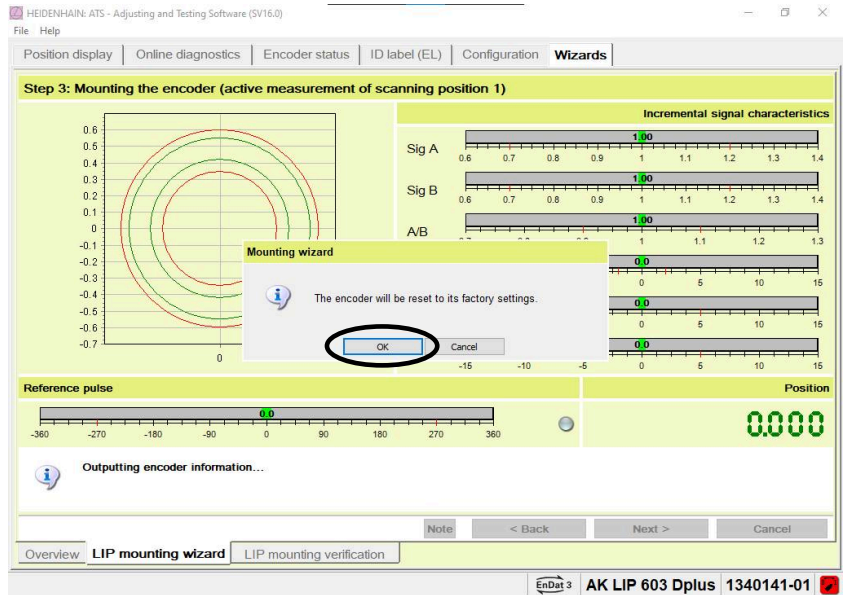

Factory default settings message

- ▶ Perform Moiré alignment

i

- Rotate the scanning head to set the maximum possible signal (Sig A, Sig B)
- Perform the alignment at standstill
- Do not perform the alignment at the reference mark

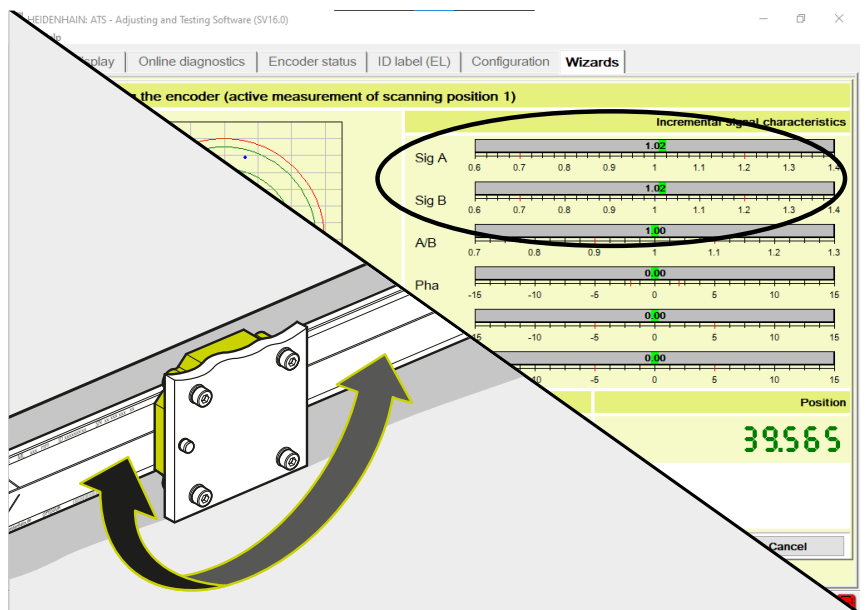

Moiré alignment

- ▶ Traverse the scanning head with 10 mm/s

i Pay attention to the adjustment information: "Adjusting the scanning head".

i The blue dot must be within the green circles.

- ▶ Click **Next**
- ▶ The message **Step 4: Adjusting** is displayed.

HEIDENHAIN: ATS - Adjusting and Testing Software (SV16.0)

Position display | Online diagnostics | Encoder status | ID label (EL) | Configuration | **Wizards**

Step 3: Mounting the encoder (active measurement of scanning position 1)

Incremental signal characteristics

Sig A: 1.02
Sig B: 1.02
A/B: 1.00
Pha: 0.00
TV A: 0.00
TV B: 0.00

Reference pulse: 75%
Position: 39.565

The encoder was reset to the factory default setting. HSP is off. The traversing speed should be approx. 10 mm/s.

Note < Back **Next >** Cancel

Overview | LIP mounting wizard | LIP mounting verification

EndDat 3 AK LIP 603 Dplus 1340141-01

Wizards tab with **Step 3: Mounting the encoder (active measurement of scanning position 1)** message

- ▶ Traverse reference mark 1 in both directions until "Progress: 100%" has been reached
- ▶ Reference mark 1 and incremental track 1 have now been adjusted.

HEIDENHAIN: ATS - Adjusting and Testing Software (SV16.0)

Position display | Online diagnostics | Encoder status | ID label (EL) | Configuration | **Wizards**

Step 4: Adjusting the incremental signals and the reference pulse (scanning position 1)

Incremental signal characteristics

Sig A: 1.02
Sig B: 1.02
A/B: 1.00
Pha: 0.00
TV A: 0.00
TV B: 0.00

Reference pulse: 59%
Position: 39.565

Automatic adjustment of reference pulse in progress. Please traverse the reference mark in both directions. Progress: 59%

Next > Cancel

Overview | LIP mounting wizard | LIP mounting verification

EndDat 3 AK LIP 603 Dplus 1340141-01

Wizards tab with **Step 4: Adjusting** message

- ▶ Traverse reference mark 2 in both directions until "Progress: 100%" has been reached
- ▶ Reference mark 2 and incremental track 2 have now been adjusted.
- ▶ The message **Step 5: Verify the adjustment** is displayed.

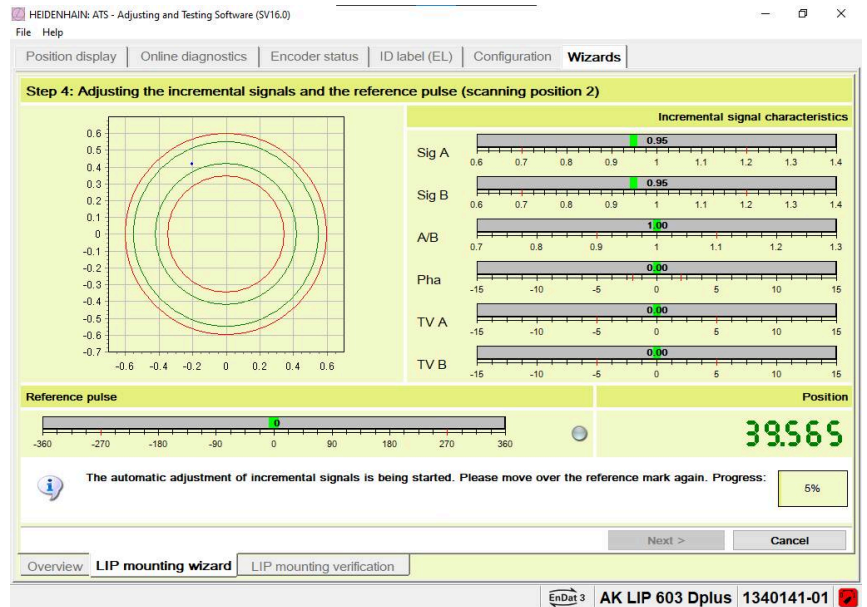

Wizards tab with **Step 4: Adjusting the incremental signals and the reference pulse (scanning position 2)** message

- ▶ Select **Scanning position**
- ▶ The signals of the selected scanning position are displayed.

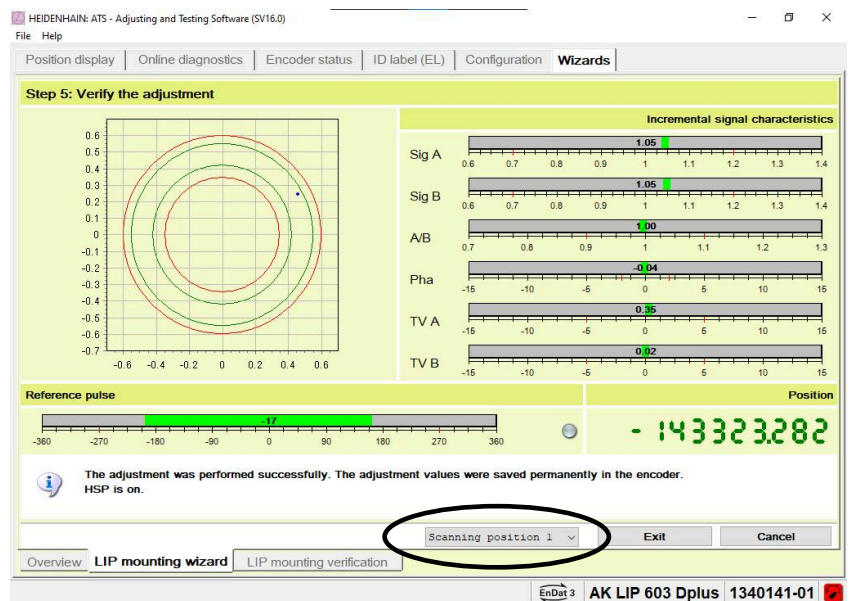

Wizards tab with **Step 5: Verify the adjustment** message

- ▶ Click **Exit**
- ▶ The adjustment was successfully concluded.

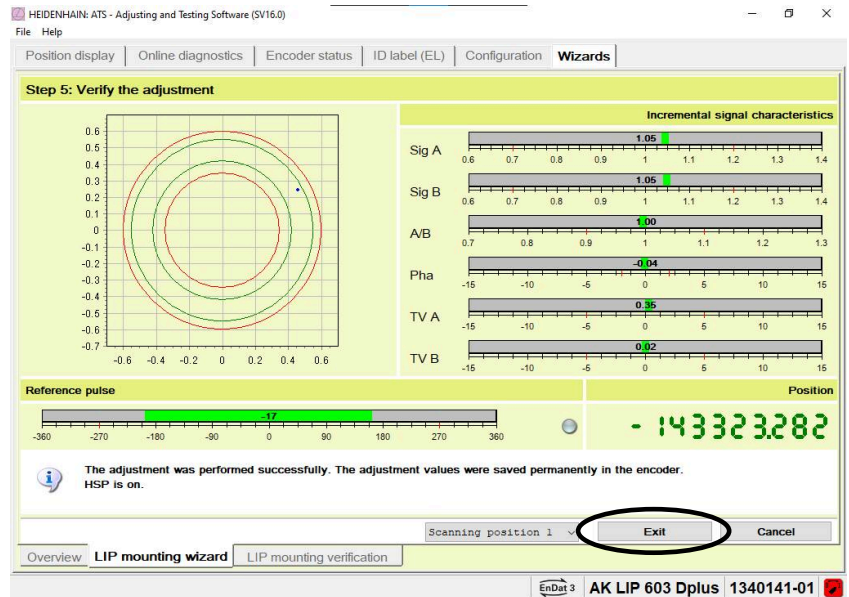

Wizards tab with **Step 5: Verify the adjustment** message

5.4 Checking the mounting

- ▶ Click the **LIP mounting verification** tab
- ▶ **Verifying the mounting using EnDat 3** is displayed.

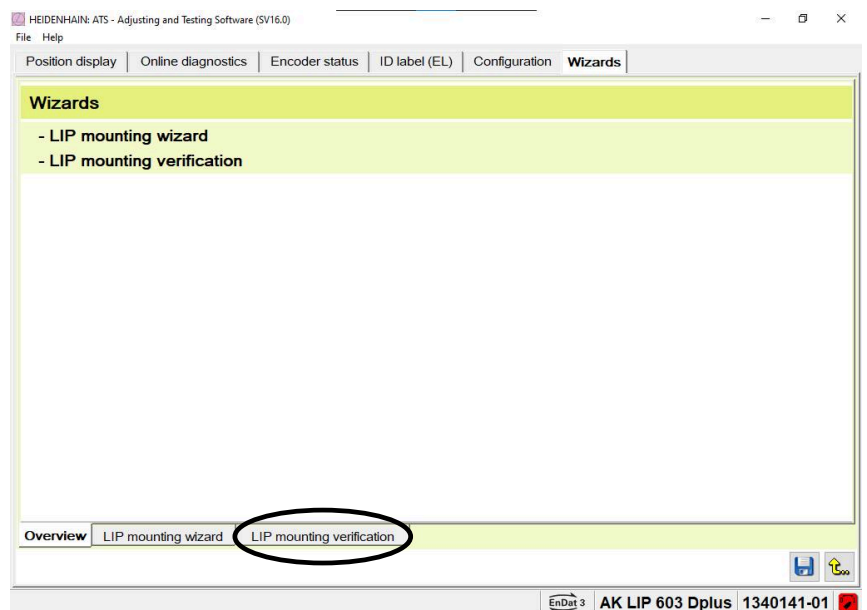

Wizards tab

- ▶ Select **Scanning position**
- ▶ The signals of the selected scanning position are displayed.

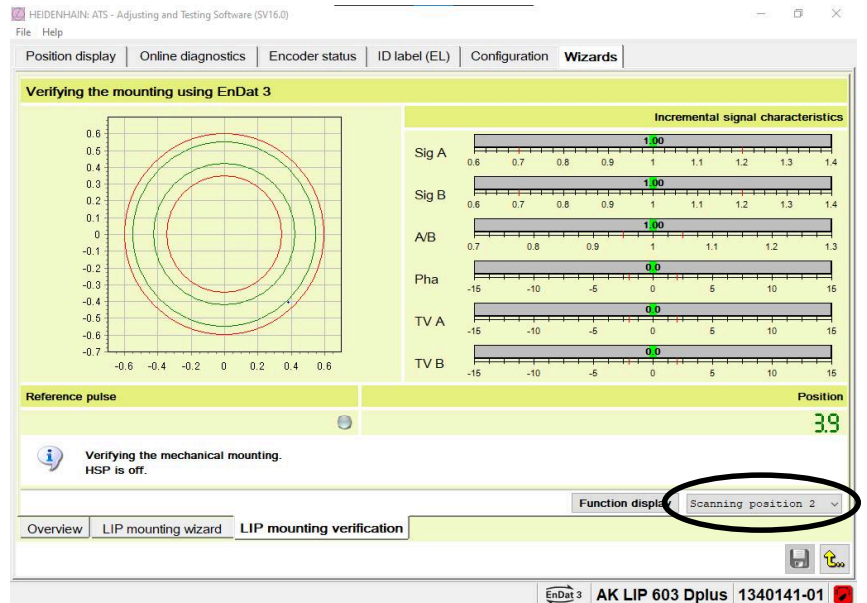

Verifying the mounting using EnDat 3

5.5 Activating/Deactivating the function display

i The function display is inactive as long as the **LIP mounting verification** tab is open.

- ▶ Click the **Wizards** tab

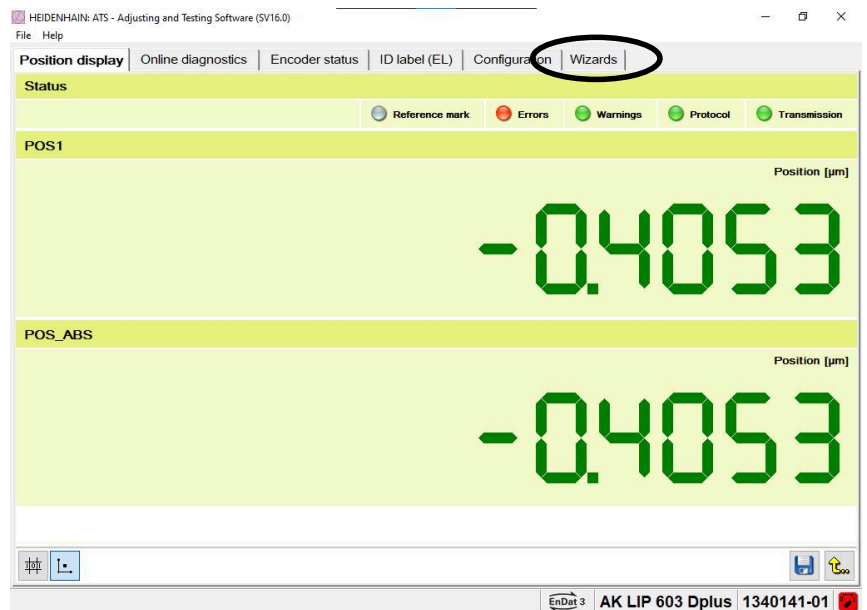

Position display tab

- ▶ Click the **LIP mounting verification** tab
- > **Verifying the mounting using EnDat 3** is displayed.

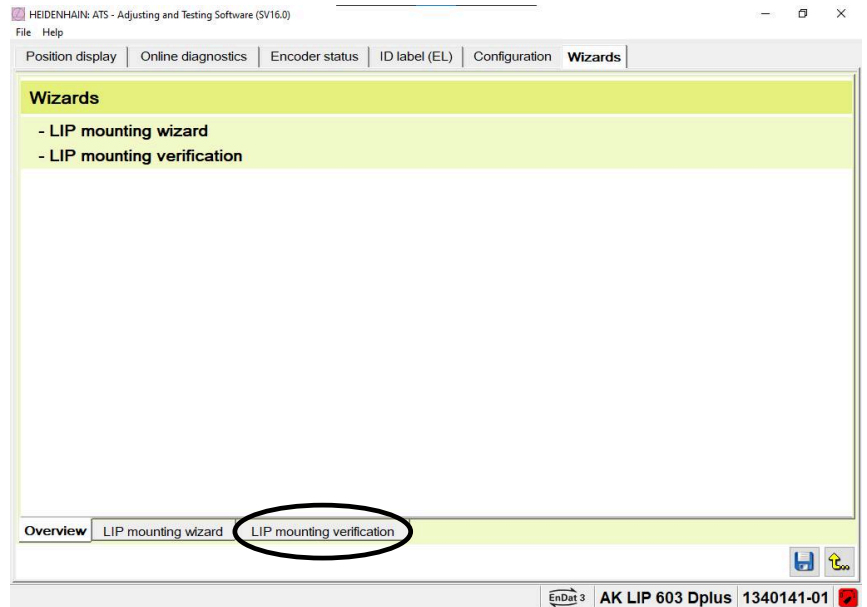

Wizards tab

- ▶ Click the **Function display** button
- > The **Mounting the encoder** note is displayed

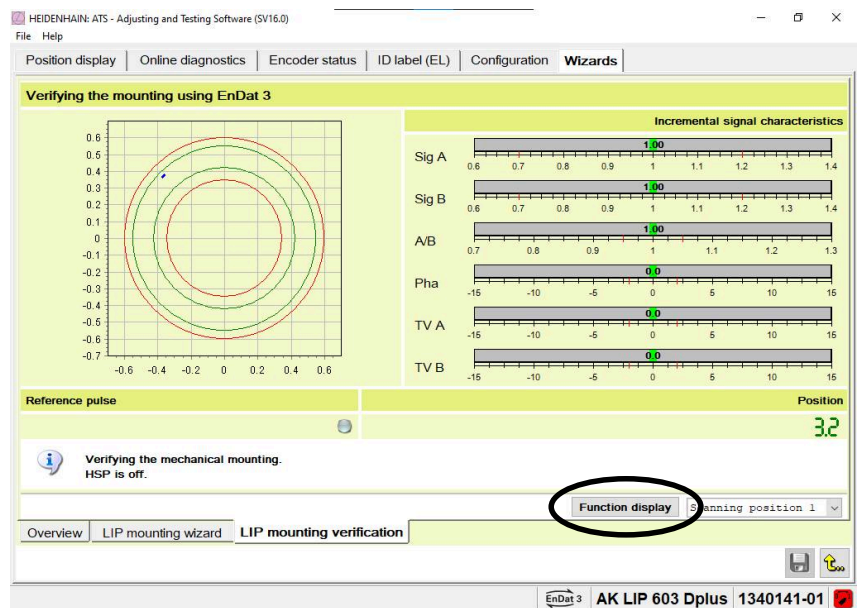

Wizards tab with Function display

- ▶ Click **OK**
- > The function display is inactive.

i Repeat the process to activate the function display.

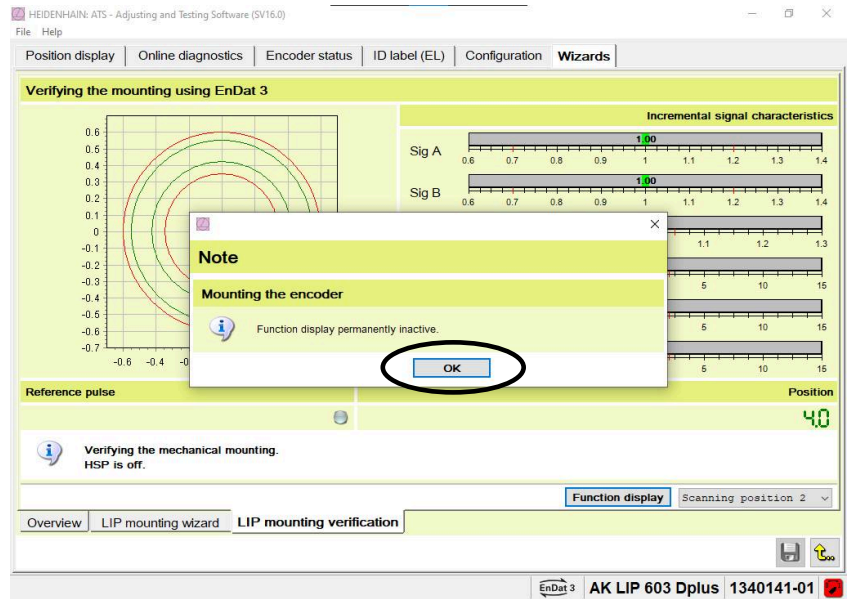

Mounting the encoder note

6 Removal

This chapter describes the disassembly of the product.

6.1 Safety precautions regarding removal

WARNING

Live plug connections

If you disengage plug connections while the equipment is under power, this may result in fatal accidents or severe personal injury.

- ▶ Do not engage or disengage any connecting elements while the product is under power

WARNING

Moving machine parts

Risk of injury due to moving machine parts depending on the installation location and the application

- ▶ Observe all of the machine manufacturer's notes on working on the machine, e.g., always disconnect the machine from the power supply

CAUTION

Fragile carrier material of the scale unit or the scale itself

Risk of injury from splinters and sharp edges of the carrier material

- ▶ Wear protective gloves and safety goggles
- ▶ Do not bend or deform the scale unit or scale excessively

6.2 Removing the scanning head

- ▶ Remove the scanning head in the reversed sequence of mounting. **Further information:** "Mounting the scanning head", Page 19

6.3 Removing the scale



Further information can be found in the **Disassembly Instructions**.

- ▶ www.heidenhain.com/documentation
- ▶ Enter the document ID **1185755**

HEIDENHAIN

DR. JOHANNES HEIDENHAIN GmbH

Dr.-Johannes-Heidenhain-Straße 5

83301 Traunreut, Germany

☎ +49 8669 31-0

☎ +49 8669 32-5061

info@heidenhain.de

Technical support ☎ +49 8669 32-1000

Measuring systems ☎ +49 8669 31-3104

service.ms-support@heidenhain.de

NC support ☎ +49 8669 31-3101

service.nc-support@heidenhain.de

NC programming ☎ +49 8669 31-3103

service.nc-pgm@heidenhain.de

PLC programming ☎ +49 8669 31-3102

service.plc@heidenhain.de

APP programming ☎ +49 8669 31-3106

service.app@heidenhain.de

www.heidenhain.com

