

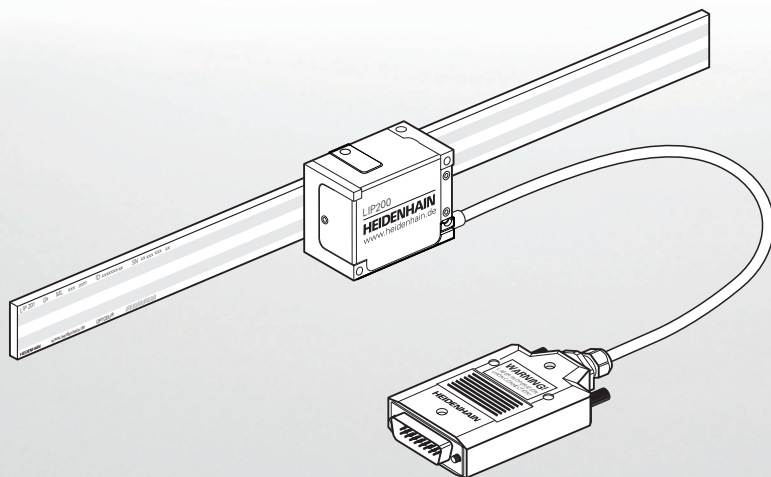

# HEIDENHAIN



## LIP 211

## LIP 281

## LIP 291

Mounting Instructions

## Table of contents

|          |   |           |
|----------|---|-----------|
| <b>1</b> | <b>Basic information.....</b>                   | <b>4</b>  |
| 1.1      | Validity of the documentation.....              | 4         |
| 1.2      | Target groups of the Mounting Instructions..... | 4         |
| 1.3      | Notes on reading the documentation.....         | 5         |
| 1.4      | Symbols and fonts used for marking text.....    | 6         |
| 1.5      | Notes in this documentation.....                | 7         |
| 1.6      | Units and tolerances.....                       | 7         |
| <b>2</b> | <b>Safety.....</b>                              | <b>8</b>  |
| 2.1      | Personnel qualification.....                    | 8         |
| 2.2      | General safety precautions.....                 | 8         |
| 2.3      | Laser radiation.....                            | 10        |
| <b>3</b> | <b>Items supplied and accessories.....</b>      | <b>11</b> |
| 3.1      | Items supplied.....                             | 11        |
| 3.1.1    | Items supplied with the linear scale.....       | 11        |
| 3.1.2    | Items supplied with the scanning head.....      | 12        |
| 3.2      | Mounting accessories.....                       | 13        |
| 3.2.1    | Accessories for mounting the linear scale.....  | 13        |
| 3.2.2    | Accessories for mounting the scanning head..... | 13        |
| 3.2.3    | Accessories for fixed-point bonding.....        | 14        |
| <b>4</b> | <b>Mounting.....</b>                            | <b>15</b> |
| 4.1      | Requirements and notes.....                     | 15        |
| 4.2      | Mounting the linear scale.....                  | 16        |
| 4.2.1    | Choosing the mounting variant.....              | 16        |
| 4.2.2    | Variant: Mounting with adhesive film.....       | 17        |
| 4.2.3    | Variant: Mounting with fixing clamps.....       | 21        |
| 4.3      | Mounting the scanning head.....                 | 27        |
| 4.3.1    | Choosing the mounting variant.....              | 27        |

|            |  |           |
|------------|--|-----------|
| 4.3.2      | Variant: Mounting with the holder on the side.....               | 28        |
| 4.3.3      | Variant: Mounting with the holder at top.....                    | 30        |
| <b>5</b>   | <b>Adjustment and diagnosis.....</b>                             | <b>32</b> |
| <b>5.1</b> | <b>Requirements and notes.....</b>                               | <b>32</b> |
| <b>5.2</b> | <b>Continuity check.....</b>                                     | <b>32</b> |
| 5.2.1      | Materials and tools.....   | 32        |
| 5.2.2      | Measuring the electrical resistance.....                         | 32        |
| <b>5.3</b> | <b>Connecting the encoder to the ATS.....</b>                    | <b>33</b> |
| 5.3.1      | Connecting the encoder.....                                      | 33        |
| 5.3.2      | Selecting the connection.....                                    | 33        |
| 5.3.3      | Connecting the encoder using its ID.....                         | 34        |
| 5.3.4      | Connecting the encoder manually.....                             | 36        |
| <b>5.4</b> | <b>Adjusting the scanning head.....</b>                          | <b>39</b> |
| 5.4.1      | Selecting the scanning head.....                                 | 39        |
| 5.4.2      | Mounting the LIP 21 or LIP 29 scanning head.....                 | 40        |
| 5.4.3      | Mounting the LIP 28 scanning head.....                           | 45        |
| <b>6</b>   | <b>Final steps.....</b>  | <b>51</b> |
| <b>6.1</b> | <b>Connecting the encoder to the downstream electronics.....</b> | <b>51</b> |
| <b>7</b>   | <b>Removal.....</b>  | <b>52</b> |
| <b>7.1</b> | <b>Safety precautions regarding removal.....</b>                 | <b>52</b> |
| <b>7.2</b> | <b>Removing the scanning head.....</b>                           | <b>52</b> |
| <b>7.3</b> | <b>Removing the scale.....</b>                                   | <b>52</b> |

## 1 Basic information

This chapter contains information about the product and the Mounting Instructions.

### 1.1 Validity of the documentation

These Mounting Instructions apply to LIP 211, LIP 281, LIP 291.

- Before using the documentation, check whether the documentation and product model match. The designation of the product is printed on the ID label.

#### ID label

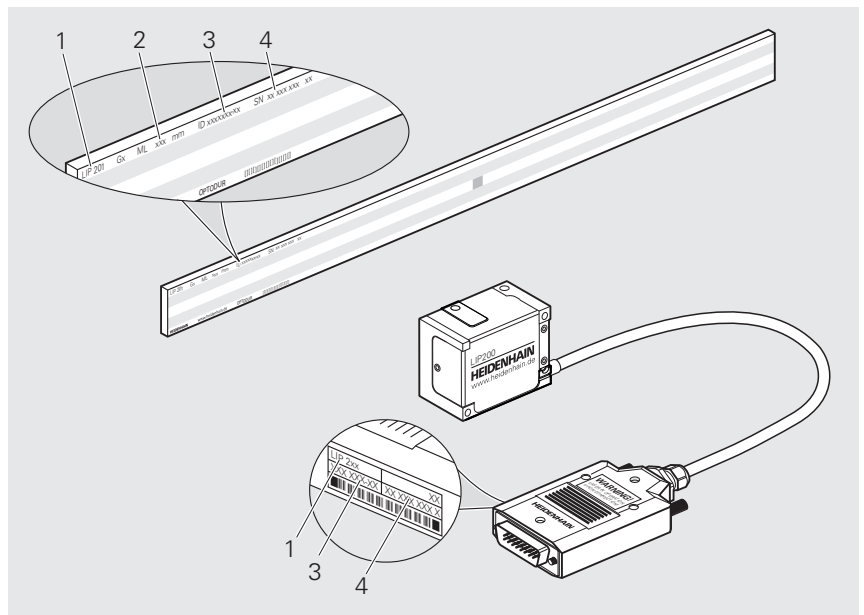

ID label with legend

- 1 Product name
- 2 Measuring length (ML)
- 3 Product ID / Part number (ID)
- 4 Serial number (SN)

### 1.2 Target groups of the Mounting Instructions

The Mounting Instructions must be read and observed by every person who performs any of the following tasks:

- Design
- Mounting
- Removal

## 1.3 Notes on reading the documentation

### WARNING

#### **Fatal accidents, personal injury or property damage caused by non-compliance with the documentation!**

Failure to comply with the documentation may result in fatal accidents, personal injury or property damage.

- ▶ Read the documentation carefully from beginning to end
- ▶ Keep the documentation for future reference

The following table lists the various parts of the documentation in their order of reading priority.

| Document type          | Description   |
|------------------------|---|
| Addendum               | An Addendum supplements or supersedes the corresponding contents of the Operating Instructions and, if applicable, of the Mounting Instructions. If an Addendum is included in the shipment, it has the highest priority for reading. All other documentation content retains its validity.   |
| Operating Instructions | The Operating Instructions contain all of the information and safety instructions for the proper and intended operation of the device. The Operating Instructions (English language version) are included in delivery and can also be downloaded in other languages from <b><a href="http://www.heidenhain.com/documentation">www.heidenhain.com/documentation</a></b> . The Operating Instructions must be read prior to initial operation of the product.<br>The Operating Instructions have the second highest priority for reading. |
| Mounting Instructions  | The Mounting Instructions contain all the information and safety precautions needed for the proper mounting and installation of a product. The Mounting Instructions are not included in delivery and must be downloaded from <b><a href="http://www.heidenhain.com/documentation">www.heidenhain.com/documentation</a></b> .<br>The Mounting Instructions have the third highest priority for reading.   |

#### **Would you like any changes, or have you found any errors?**

We are continuously striving to improve our documentation for you. Please help us by sending your suggestions to the following e-mail address:

**[userdoc@heidenhain.de](mailto:userdoc@heidenhain.de)**

## 1.4 Symbols and fonts used for marking text

In these instructions the following symbols and fonts are used for marking text:

| Format | Meaning   |
|--------|---|
| ▶ ...  | Identifies an action and the result of this action  |
| > ...  | Example: <ul style="list-style-type: none"><li>▶ Tilt the shipping brace to remove it <b>(c)</b></li><li>&gt; The shipping brace has been removed now</li></ul> |
| ■ ...  | Identifies an item of a list  |
| ■ ...  | Example: <ul style="list-style-type: none"><li>■ Solid contaminants: class 3</li><li>■ Max. pressure dew point: class 4</li></ul>                               |

## 1.5 Notes in this documentation

### Safety precautions

Precautionary statements warn of hazards in handling the product and provide information on their prevention. Precautionary statements are classified by hazard severity and divided into the following groups:

#### DANGER

**Danger** indicates hazards for persons. If you do not follow the avoidance instructions, the hazard **will result in death or severe injury**.

#### WARNING

**Warning** indicates hazards for persons. If you do not follow the avoidance instructions, the hazard **could result in death or serious injury**.

#### CAUTION

**Caution** indicates hazards for persons. If you do not follow the avoidance instructions, the hazard **could result in minor or moderate injury**.

#### NOTICE

**Notice** indicates danger to material or data. If you do not follow the avoidance instructions, the hazard **could result in property damage**.

### Informational notes

Informational notes ensure reliable and efficient operation of the product. Informational notes are divided into the following groups:



The information symbol indicates a **tip**.  
A tip provides important additional or supplementary information.



The book symbol indicates a **cross reference**.  
A cross reference leads to external documentation, for example: further documentation from HEIDENHAIN or another supplier.

## 1.6 Units and tolerances

Unless otherwise specified, the dimensions stated in these Mounting Instructions are given in millimeters.

Unless otherwise specified, the tolerances stated in these Mounting Instructions conform to ISO 8015 and ISO 2768 standards.

mm



Tolerancing ISO 8015  
ISO 2768:1989-mH  
≤ 6 mm: ±0.2 mm

## 2 Safety

This chapter provides important safety information needed for the proper mounting and installation of the product.

### 2.1 Personnel qualification

Mounting, initial configuration and removal must be conducted by a qualified specialist under compliance with local safety regulations.

### 2.2 General safety precautions

#### WARNING

##### **Risk of injury from laser radiation!**

Class 3B laser exposure causes serious eye and skin injuries.

- ▶ Mount the scanning head correctly
- ▶ Wear eye protection, protective clothing and protective gloves
- ▶ Never stare into the laser beam or the reflection of the laser beam
- ▶ Do not touch the laser beam
- ▶ Shield the laser beam
- ▶ Structurally prevent reflections of the laser beam

#### WARNING

##### **Danger of electric shock due to connection to unsuitable downstream electronics!**

If you connect unsuitable downstream electronics to the product, fatal accidents or severe personal injuries can occur.

- ▶ Connect the product only to downstream electronics whose supply voltage comes from PELV systems

#### WARNING

##### **Live plug connections!**

If you disengage plug connections while the equipment is under power, this may result in fatal accidents or severe personal injury.

- ▶ Do not engage or disengage any connecting elements while the product is under power

#### WARNING

##### **Risk of injury from damaged or worn components!**

Safety functions can fail if damaged or worn components are installed unintentionally. Failed safety functions can result in death or serious injury.

- ▶ Inspect the component for damage
- ▶ Do not use any damaged or worn components
- ▶ In case of replacement, repair the thread
- ▶ Use new screws, spring pins and nuts
- ▶ Secure screws and nuts with suitable material-bonding anti-rotation lock

**NOTICE****Property damage due to mechanical stress!**

- ▶ Do not drop the product or subject it to major vibration
- ▶ Do not expose the product to mechanical stress
- ▶ Do not change the physical structure of the product

**NOTICE****Property damage due to electrical stress!**

- ▶ Do not engage or disengage any connecting elements while the product is under power
- ▶ Do not touch the contacts of the plug connections

**NOTICE****Electrostatic discharge (ESD)!**

This product contains electrostatically sensitive components that can be destroyed by electrostatic discharge (ESD).

- ▶ It is essential to observe the safety precautions for handling ESD-sensitive components
- ▶ Never touch connector pins without ensuring proper grounding
- ▶ Wear a grounded ESD wristband when handling the connections of the product

## 2.3 Laser radiation

A class 3B laser is installed in the encoder. See the sticker on the encoder for more detailed information about the emitted laser radiation.

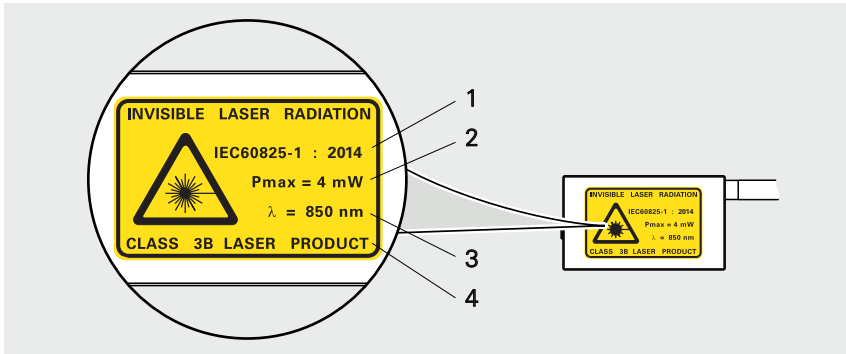

- 1 Underlying technical standard
- 2 Maximum emitted power or energy
- 3 Wavelength
- 4 Laser class





When mounted in accordance with the Mounting Instructions, the device fulfills the requirements of laser protection class 1 when installed.

### 3 Items supplied and accessories

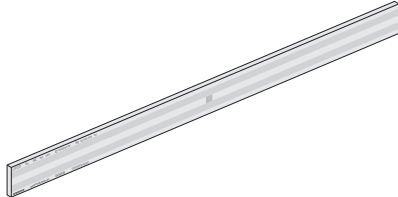
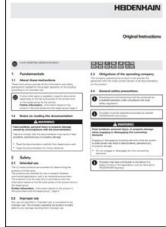

This chapter contains information on the items supplied and the available accessories of the product.

#### 3.1 Items supplied

##### 3.1.1 Items supplied with the linear scale

| Component                   | Figure  |
|-----------------------------|---|
| Scale                       |   |
| Operating Instructions      |   |
| Quality Inspection Document |  |

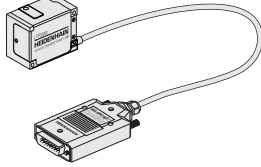
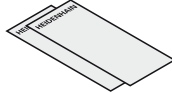
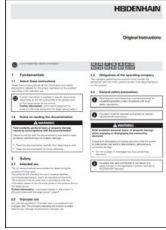
### 3.1.2 Items supplied with the scanning head

| Component                          | Figure  |
|------------------------------------|---|
| Scanning head                      |   |
| Spacer shims                       |    |
| Operating Instructions             |    |
| Manufacturer's Inspection Document |  |

## 3.2 Mounting accessories

The following accessories can be ordered separately from HEIDENHAIN.



For more information on the listed products, please refer to the applicable Mounting Instructions and the **Exposed Linear Encoders** brochure.



- ▶ [www.heidenhain.com/documentation](http://www.heidenhain.com/documentation)
- ▶ Enter the document ID **208960**

### 3.2.1 Accessories for mounting the linear scale

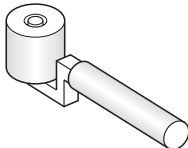
#### Accessories for mounting with adhesive film

| Designation | ID        | Figure  |
|-------------|-----------|---|
| Roller      | 276885-01 |  |

#### Accessories for mounting with fixing clamps

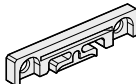
| Designation          | ID         | Figure  |
|----------------------|------------|---|
| Spacer shim          | 1176441-xx |  |
| Fixing clamps        | 1176458-xx |  |
| Fixed-point elements | 1176475-xx |  |

### 3.2.2 Accessories for mounting the scanning head

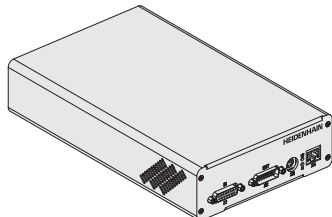
| Designation              | ID         | Figure  |
|--------------------------|------------|---|
| PWM 21 inspection device | 1200635-51 |  |

#### Adjusting and Testing Software (ATS)

The ATS software is available for download free of charge from [www.heidenhain.com/service/downloads/software/](http://www.heidenhain.com/service/downloads/software/).

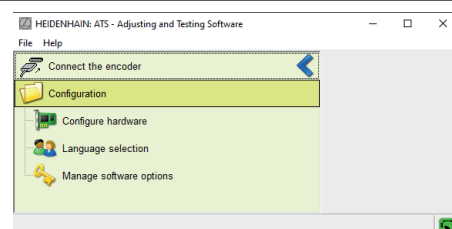

### 3.2.3 Accessories for fixed-point bonding

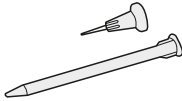
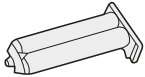
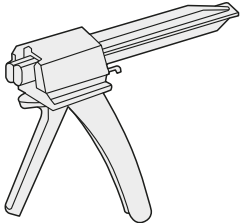
| Designation                         | ID         | Figure  |
|-------------------------------------|------------|---|
| Dispensing nozzles and mixing tubes | 1176444-01 |  |
| Adhesive 3M DP 460 EG               | 1180444-01 |  |
| Double-cartridge gun                | 1180450-01 |  |

## 4 Mounting

This chapter describes the mounting requirements, different mounting variants, and all other tasks necessary when mounting.

### 4.1 Requirements and notes

#### NOTICE

##### Property damage due to inappropriate tools!

Using inappropriate tools for mounting or removal of the encoder may cause damage to the encoder.

- ▶ Do not use hammers
- ▶ Do not use pointed or sharp-edged tools

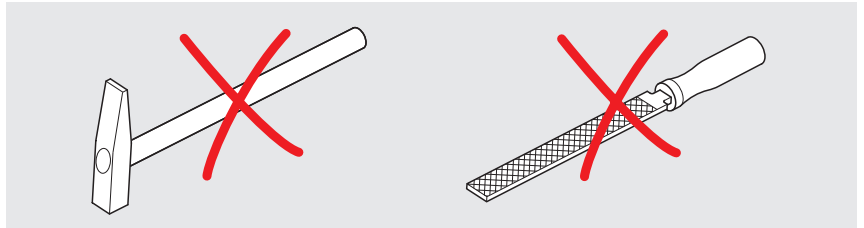

Choose a mounting attitude such that the traverse range is within the measuring length (ML) of the encoder.

(S) = Beginning of measuring length (ML)

Protect the graduation from direct contamination.

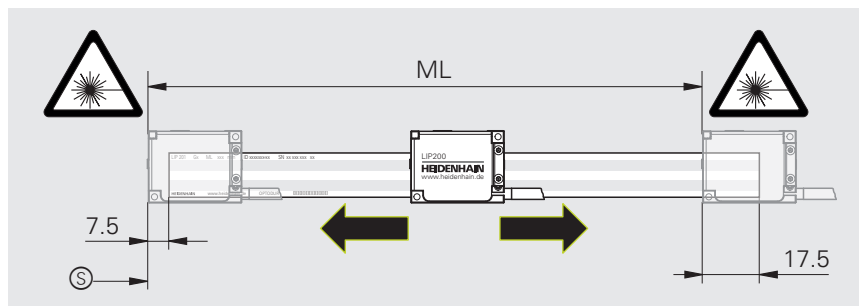

#### WARNING

##### Risk of injury from laser radiation!

There is a risk of injury from laser radiation if the indicated measuring length is exceeded.

- ▶ Move the scanning unit only within the specified measuring length

In order to ensure correct operation of the encoder, the scale must be positioned correctly relative to the scanning head.

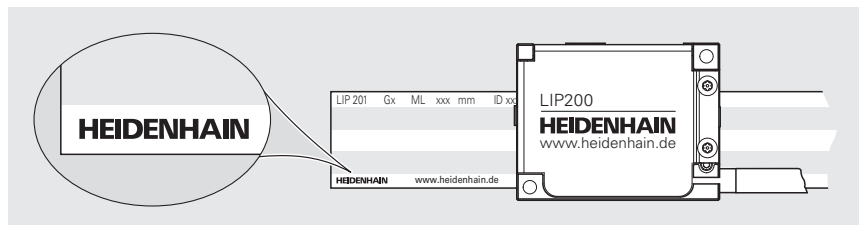

In order to avoid signal interferences, observe the minimum clearance from sources of interference (e.g., power lines).



For more information on sources of interference, refer to the **Interfaces of HEIDENHAIN Encoders** brochure.

- ▶ [www.heidenhain.com/documentation](http://www.heidenhain.com/documentation)
- ▶ Enter the document ID **1078628**

## 4.2 Mounting the linear scale

### 4.2.1 Choosing the mounting variant

#### Mounting variants for the linear scale

Mounting **with adhesive film**

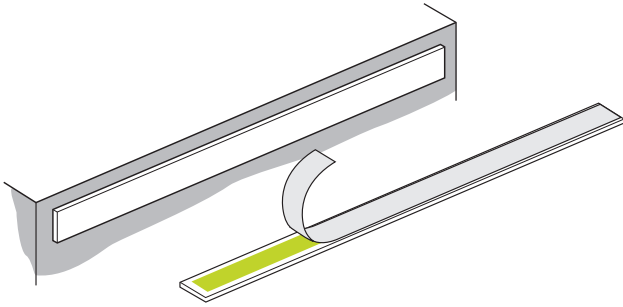

Page 17

Mounting **with fixing clamps**

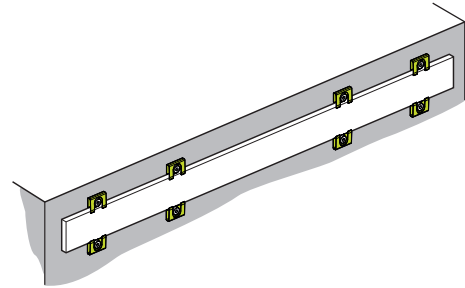

Page 21

### 4.2.2 Variant: Mounting with adhesive film

The mounting variant described in this chapter refers to mounting of the linear scale with an adhesive film.

An overview of the mounting variants is provided on Page 16.

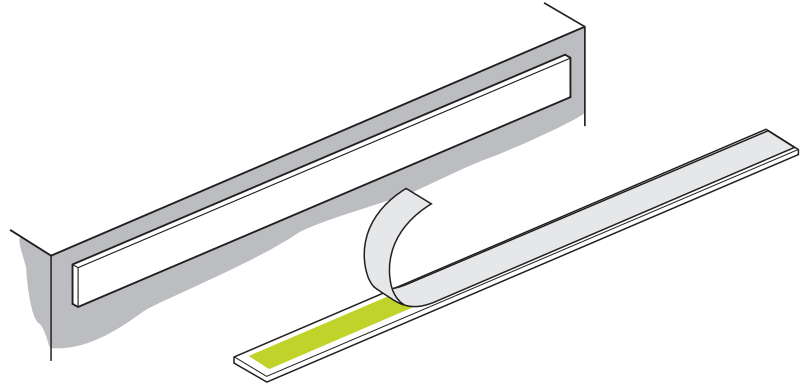

#### Notes on mounting with adhesive film

Note that the mounting surface, as well as the surface of the scale, must be clean and free of paint, dust or grease.

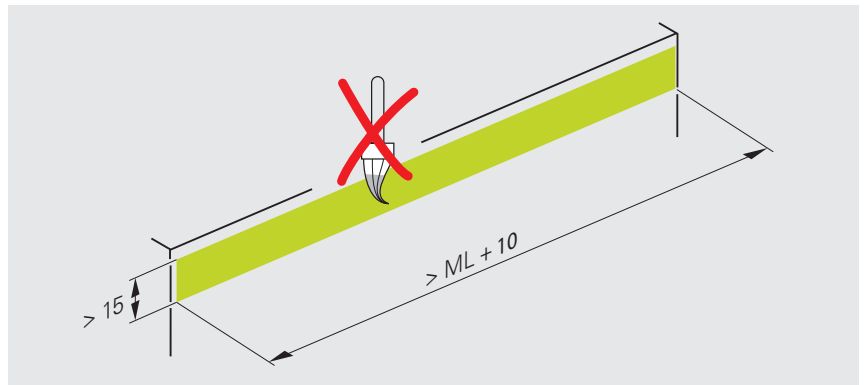

**i** You can mount the linear scale by means of stop pins or an aligning rail.

The mounting tolerances refer to the machine guideway (**F**).

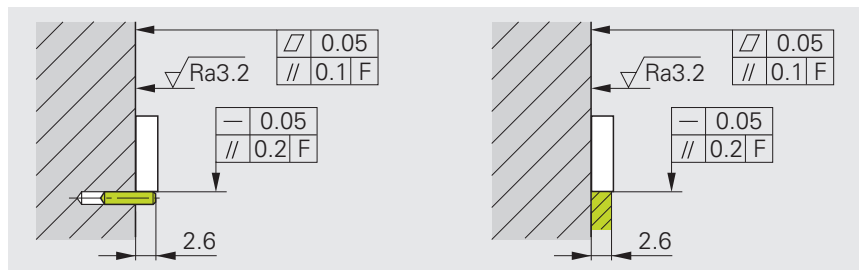

**Number of stop pins to be used**

Recommended diameter of the stop pins: 3 mm.

For a measuring length of **ML ≤ 2040**, use three stop pins to stabilize the scale sufficiently.

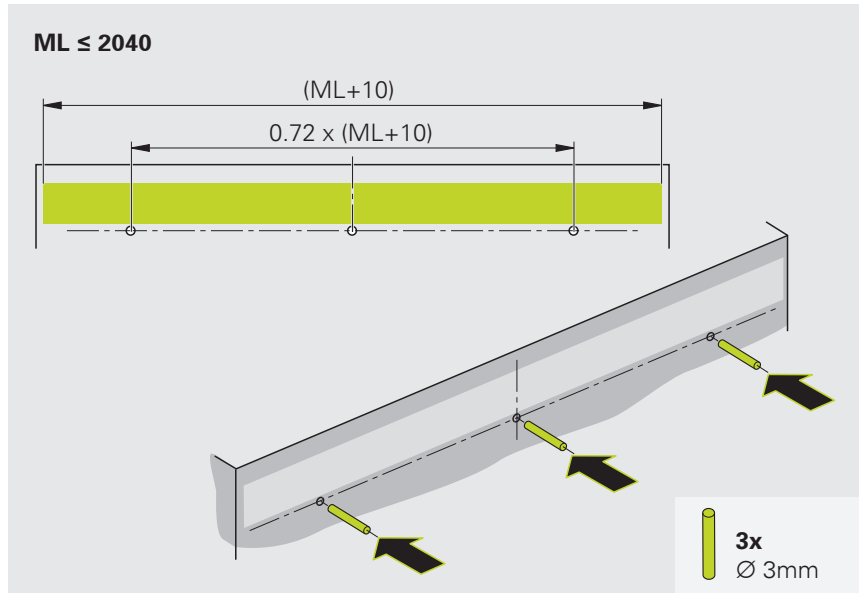

For a measuring length of **ML > 2040**, use five stop pins to stabilize the scale sufficiently.

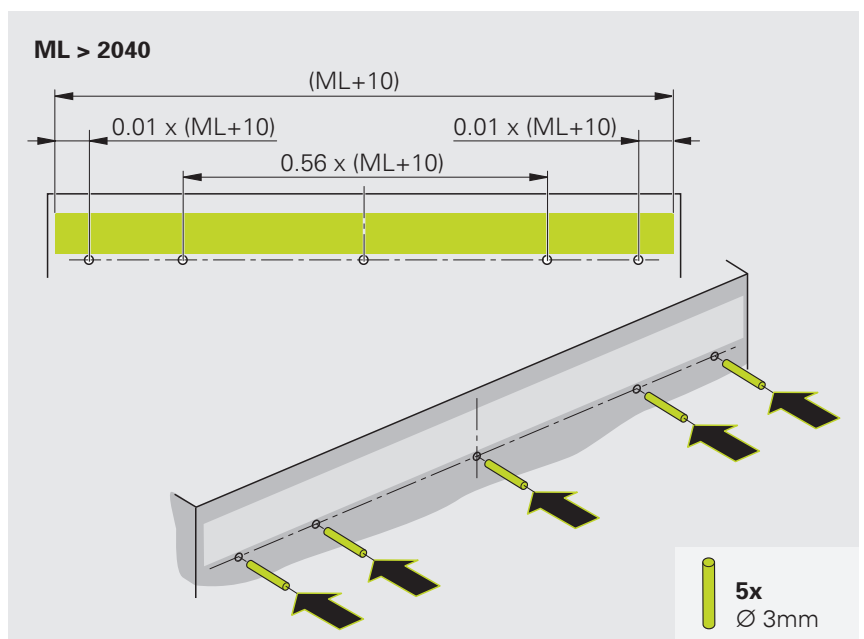

**Materials and tools**

For this task, the following materials and tools are needed:

**Included in delivery**

**To be provided separately**

- Stop pins
- Roller
- Dispensing nozzle and mixing tubes
- Adhesive 3M DP 460 EG
- Double-cartridge gun

**Gluing the linear scale**

Attach the scale with adhesive mounting film only at a temperature of > 15 °C.

Pay attention to the expiration date on the package.

- ▶ Insert the stop pins
- ▶ Remove the protective foil from the adhesive film

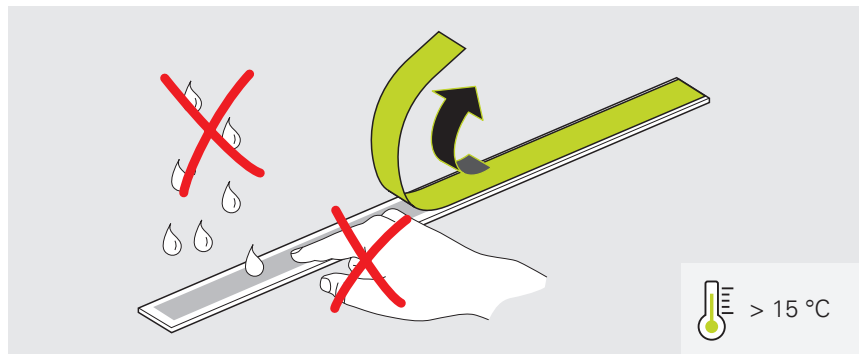

- ▶ Carefully place the scale onto the stop pins
- ▶ Starting from the center, evenly press the scale onto the mounting surface using the roller
- ▶ Remove the stop pins

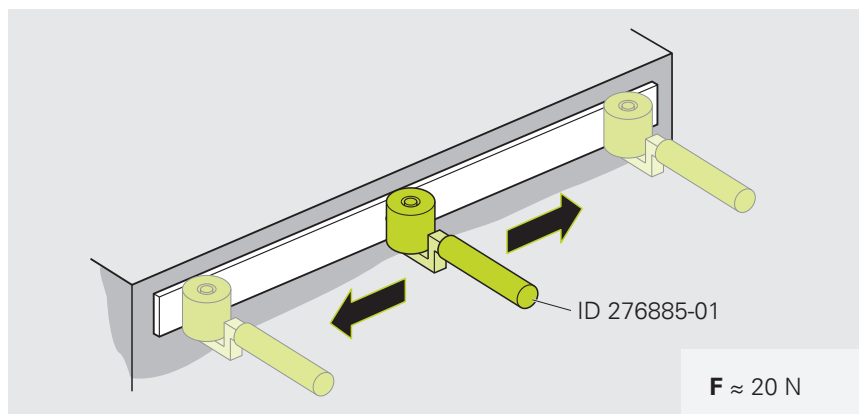

- ▶ Do not perform further work on the linear scale until the maximum adhesive force has been reached

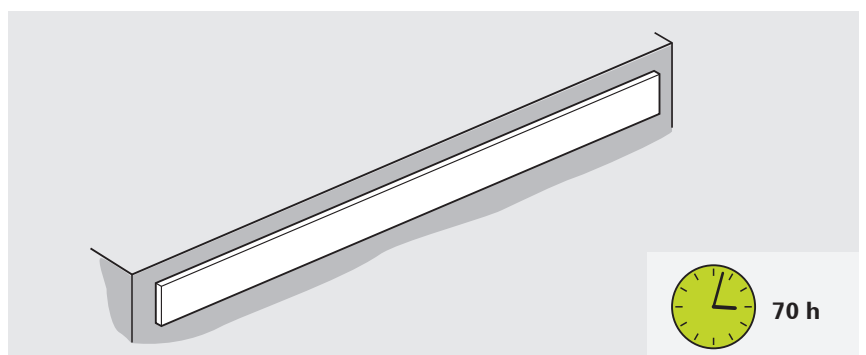

**i** The maximum adhesive force of the mounting film is reached at room temperature after approx. 70 hours.

### Bonding the fixed point

Due to potential thermal effects, HEIDENHAIN recommends fixed-point bonding at the center.

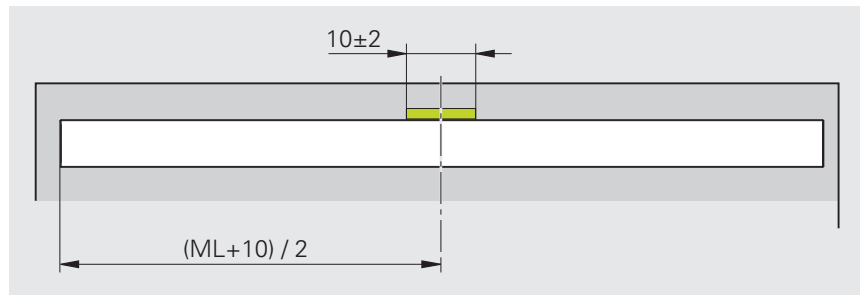

**i** Pay attention to the work instructions in the applicable documentation.

**i** Do not add more adhesive afterwards.

- ▶ Apply a bead of adhesive with a double cartridge gun and a dispensing nozzle
- ▶ Allow the adhesive to harden as appropriate for the intended operating temperature

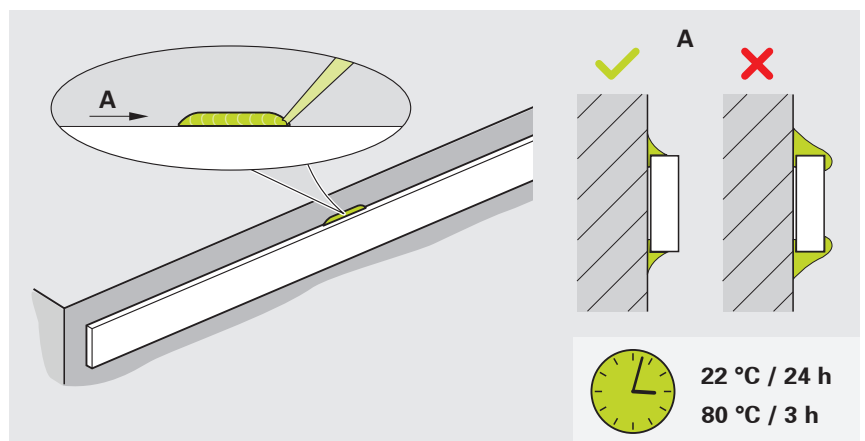

To ensure high fixed-point rigidity, pay attention to the specifications for curing temperature and curing time.

| Operating temperature | Curing temperature | Curing time |
|-----------------------|--------------------|-------------|
| -10 °C to +30 °C      | 22 °C              | 24 hours    |
| -10 °C to +70 °C      | 80 °C              | 3 hours     |

**Next step:** "Mounting the scanning head", Page 27

### 4.2.3 Variant: Mounting with fixing clamps

The mounting variant described in this chapter refers to mounting of the linear scale with fixing clamps.

An overview of the mounting variants is provided on Page 16.

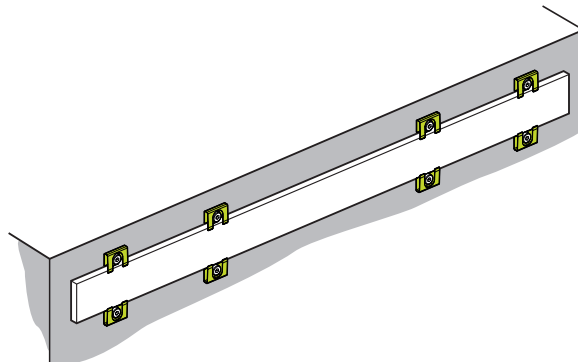

#### Notes on mounting with fixing clamps

Note that the mounting surface, as well as the surface of the scale, must be clean and free of paint, dust or grease.

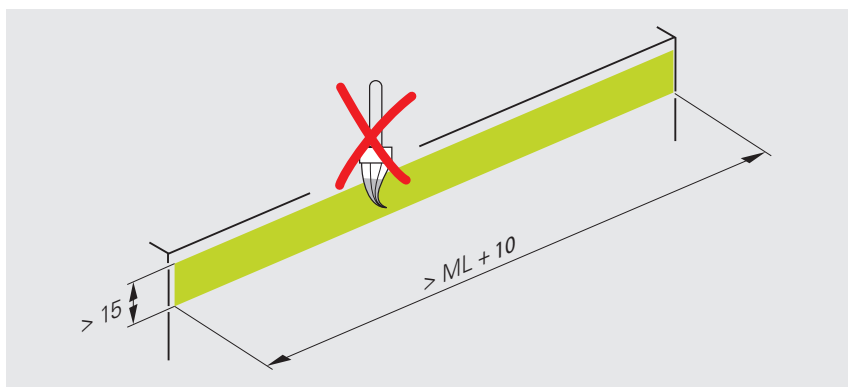

The mounting tolerances refer to the machine guideway (**F**).

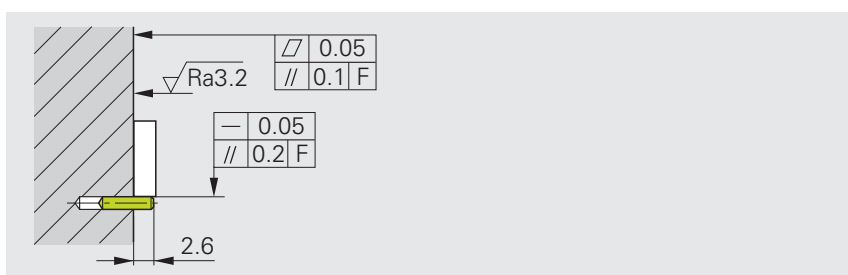

**Number of stop pins to be used**

Recommended diameter of the stop pins: 3 mm.

For a measuring length of **ML ≤ 2040**, use three stop pins to stabilize the scale sufficiently.

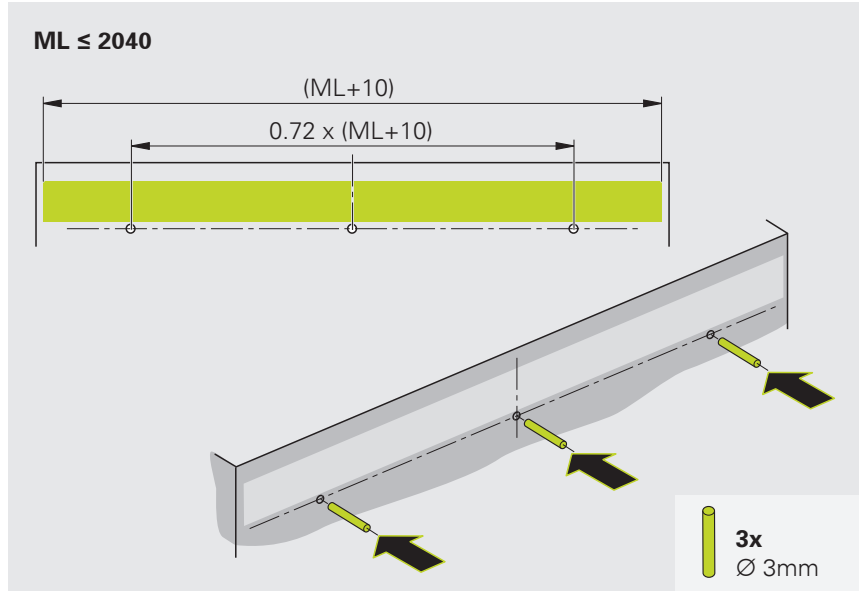

For a measuring length of **ML > 2040**, use five stop pins to stabilize the scale sufficiently.

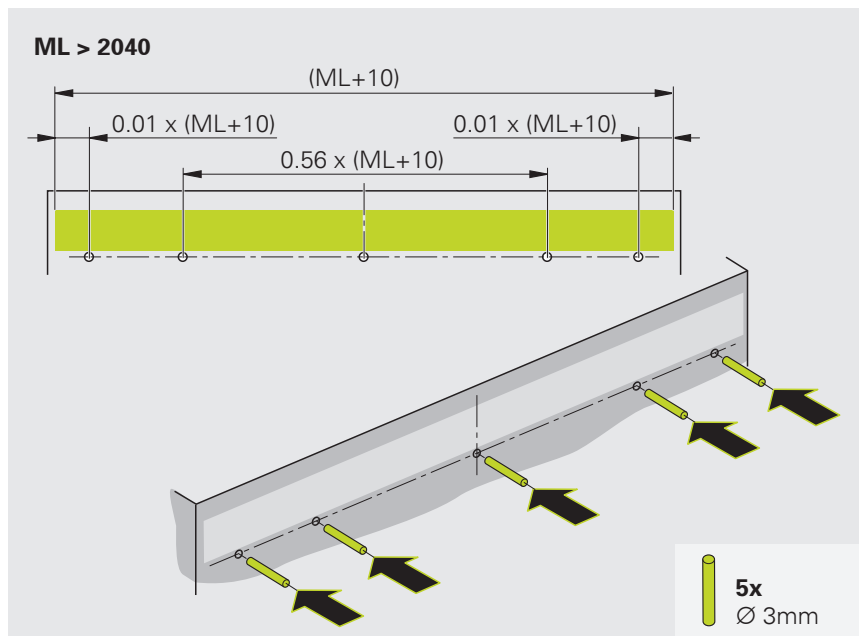

## Materials and tools

For this task, the following materials and tools are needed:

### Included in delivery

### To be provided separately

- Fixing clamps
- Spacer shims
- Stop pins
- Fixed-point elements
- Screws (DIN 7984 – M3x6)
- Washers (ISO 7092–3)
- Torque wrench (hexagon socket for 2.5 mm)
- Dispensing nozzle and mixing tubes
- Adhesive 3M DP 460 EG
- Double-cartridge gun

### Mounting the fixing clamps

- ▶ Insert the stop pins
- ▶ Remove the protective film of the scale
- ▶ Carefully place the scale onto the stop pins

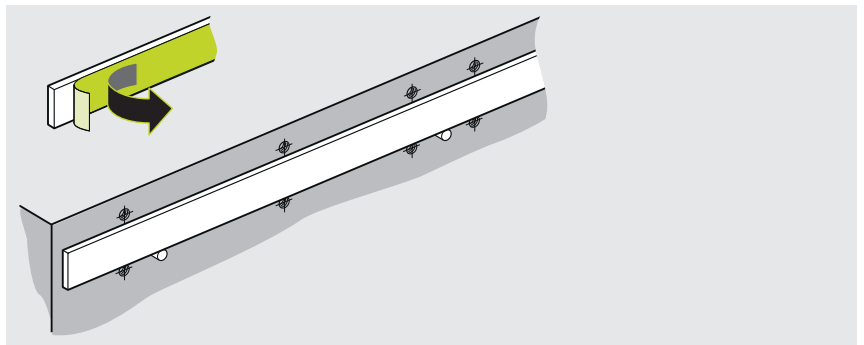

- ▶ Press all fixing clamps lightly in the direction of the scale and fasten them with screws and washers. Tighten the screws only lightly

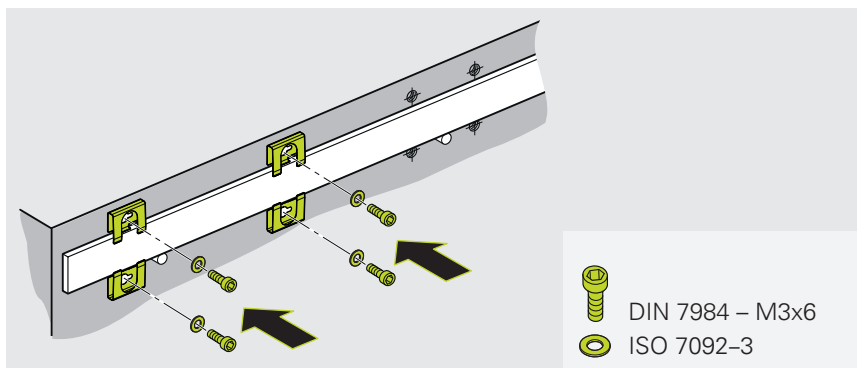

Perform the following steps only with those fixing clamps that are nearest to, but across from, a stop pin:



For a measuring length of  
 $ML \leq 2040$   
 = 2 fixing clamps  
 For a measuring length of  
 $ML > 2040$   
 = 4 fixing clamps

**ML ≤ 2040**  
 = 2x

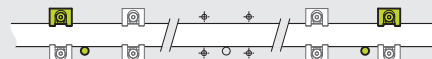

**ML > 2040**  
 = 4x

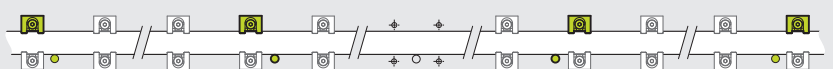

- ▶ Place the spacer shim between the fixing clamp and scale
- ▶ Align the fixing clamp at a right angle to the scale
- ▶ Tighten the screw using the prescribed torque



Do not remove the spacer shims.

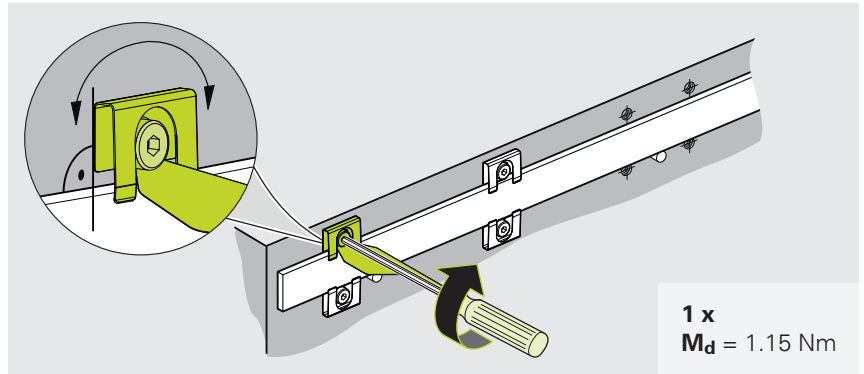

### Mounting the fixed-point element

Pay attention to the mounting dimensions. Deviations from the mounting dimensions lead to imprecise measurement results during operation.

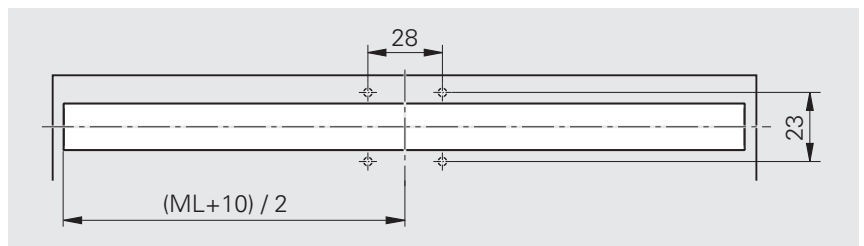

- ▶ Align the fixed-point element in parallel
- ▶ Lightly press the upper fixed-point element against the scale and fasten it with screws using the prescribed torque

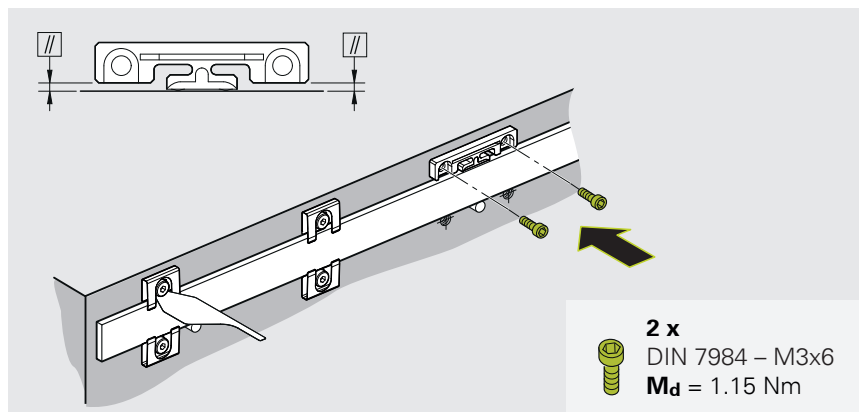

- ▶ Remove the stop pin

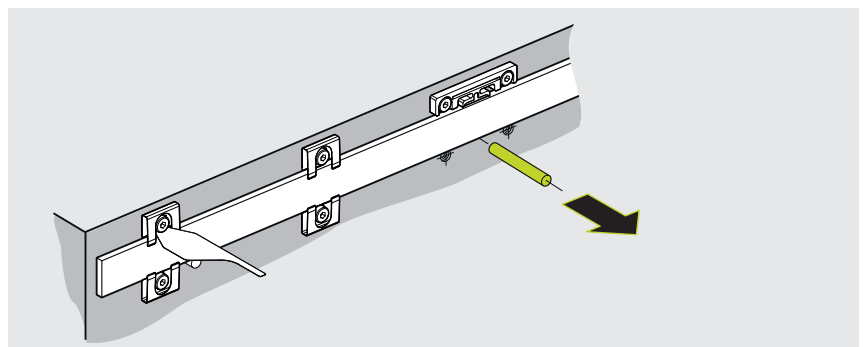

- ▶ Align the fixed-point element in parallel
- ▶ Lightly press the lower fixed-point element against the scale and fasten it with screws using the prescribed torque

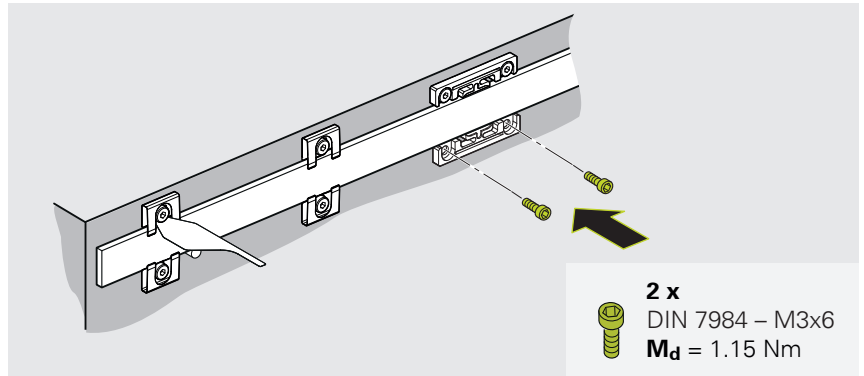

### Tightening the fixing clamps

- i**
- The figure shows an example. The number and position of the fixing clamps and stop pins depends on the length of the linear scale.
  - Always tighten the fixing clamps in pairs.

- ▶ Place the spacer shims between each pair of fixing clamps and the scale
- ▶ Tighten the screws using the prescribed torque
- ▶ Remove the spacer shims and use them for the next pair of fixing clamps
- ▶ Tighten the screws in the sequence shown

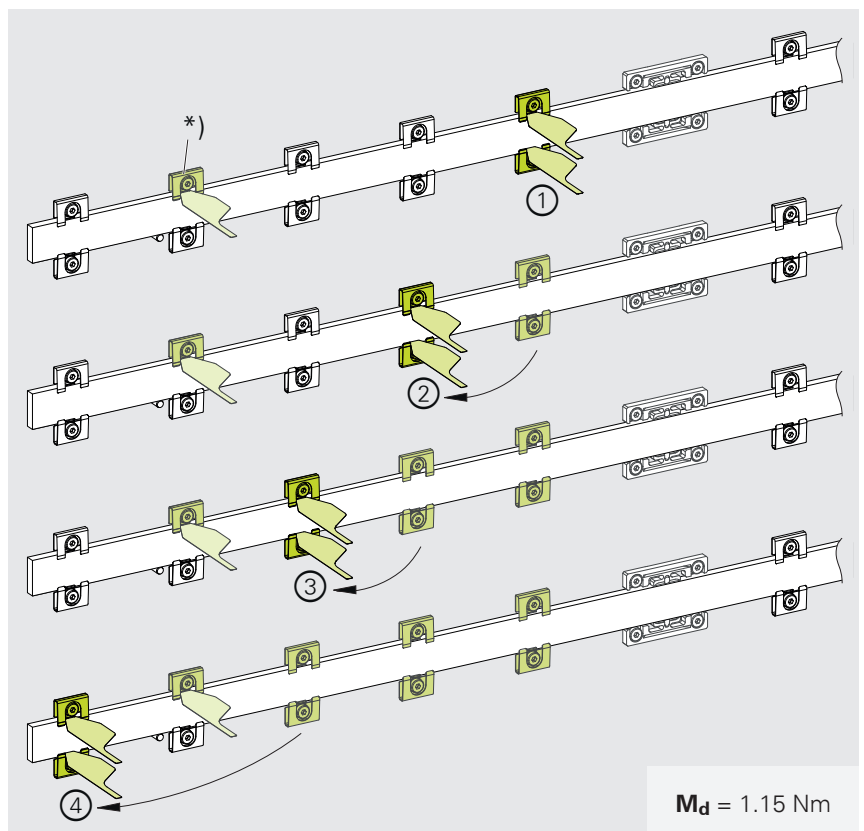

\*) Do not remove the spacer shims from the first tightened fixing clamps until all fixing clamps have been tightened.

- ▶ Remove the stop pin
- ▶ Finally, tighten the fixing clamp opposite the first fixing clamp that was tightened
- ▶ Tighten the screws on the other side of the fixed-point element according to the same pattern

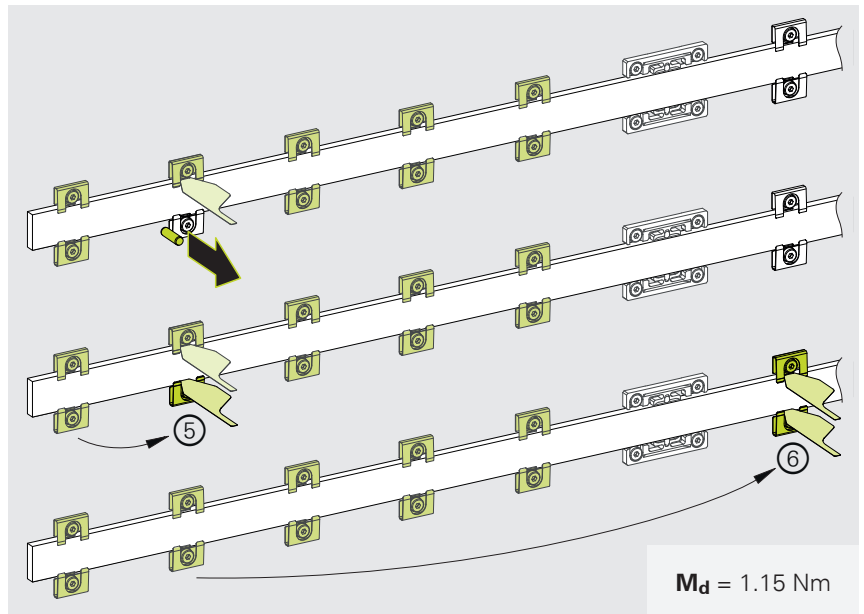

### Bonding the fixed-point elements

**i** Pay attention to the work instructions in the applicable documentation.

**i** Do not add more adhesive afterwards.

- ▶ Apply a bead of adhesive with a double cartridge gun and a dispensing nozzle
- ▶ Allow the adhesive to harden as appropriate for the intended operating temperature

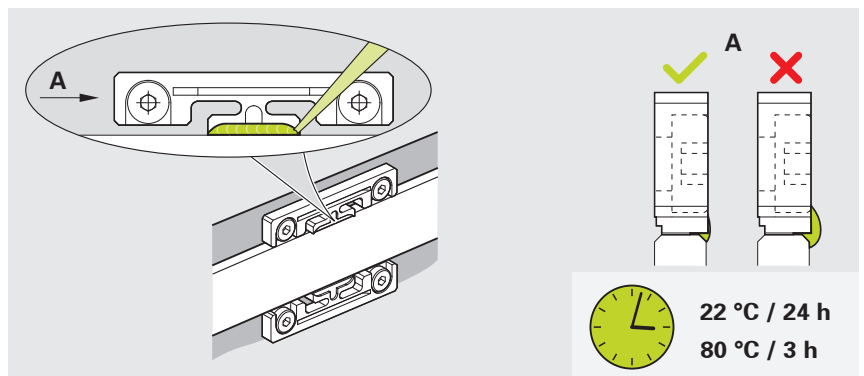

To ensure high fixed-point rigidity, pay attention to the specifications for curing temperature and curing time.

| Operating temperature | Curing temperature | Curing time |
|-----------------------|--------------------|-------------|
| -10 °C to +30 °C      | 22 °C              | 24 hours    |
| -10 °C to +70 °C      | 80 °C              | 3 hours     |

**Next step:** "Mounting the scanning head", Page 27

## 4.3 Mounting the scanning head

### 4.3.1 Choosing the mounting variant

#### Mounting variants for the scanning head

Holder **on the side**

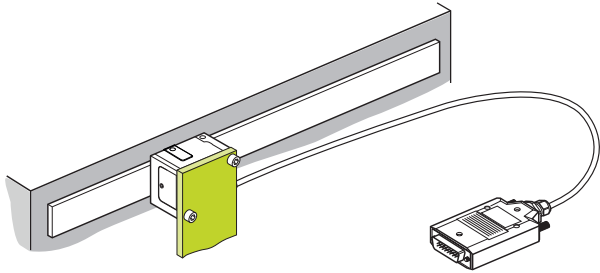

Page 28

Holder **at the top**

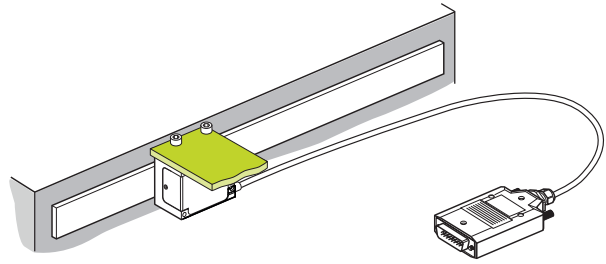

Page 30

### 4.3.2 Variant: Mounting with the holder on the side

The mounting variant described in this chapter refers to mounting of the scanning head with the holder on the side.

An overview of the mounting variants is provided on Page 27.

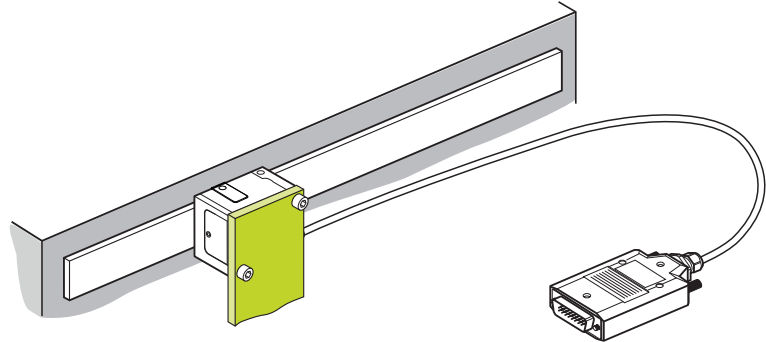

#### Notes on mounting the scanning head with the holder on the side

**i** The tightening torques of the mounting screws are only valid for mounting on steel.

#### NOTICE

##### Property damage due to unsuitable cleaning agents!

- ▶ Use only isopropyl alcohol to clean the encoder
  - ▶ Clean the encoder with a lint-free cloth
- ▶ If necessary, clean the graduation and the scanning head with a lint-free cloth and isopropyl alcohol

Pay attention to the mounting dimensions. Deviations from the mounting dimensions lead to imprecise measurement results during operation.

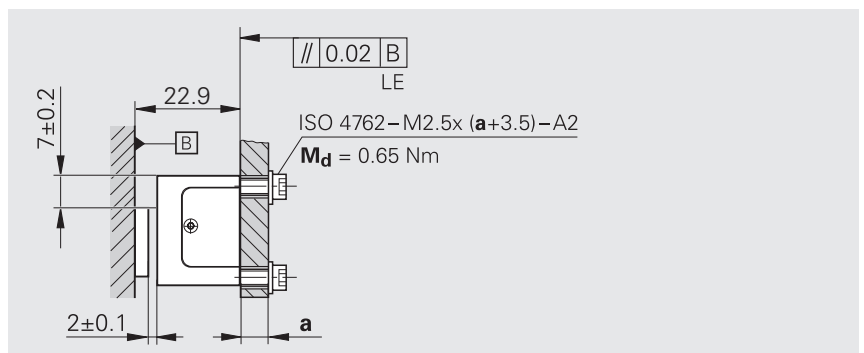
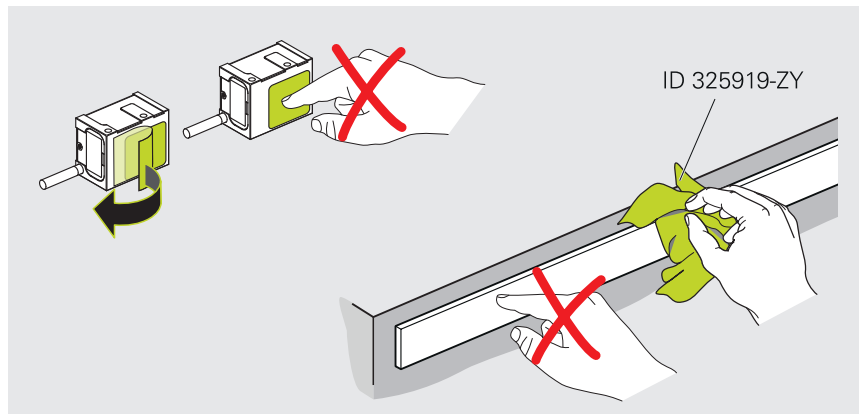

**Materials and tools**

For this task, the following materials and tools are needed:

**Included in delivery**

- Spacer shims

**To be provided separately**

- 2 screws (ISO 4762 – M2.5x(a+3.5))
- Torque wrench (hexagon socket for 2 mm)

**Mounting the scanning head**

- ▶ Remove the protective film from the scanning head
- ▶ If necessary, remove the protective film from the scale

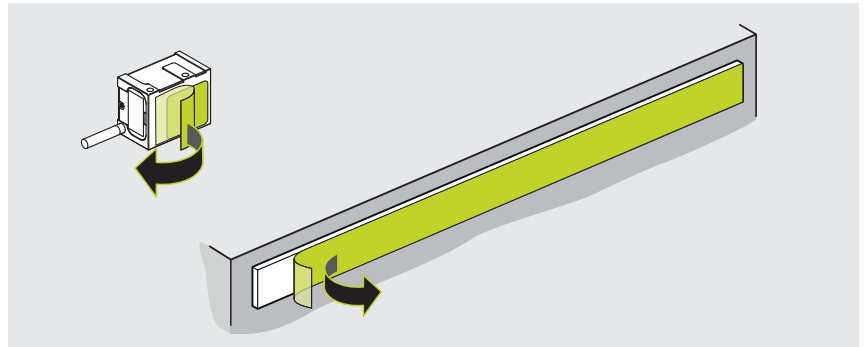

- ▶ If necessary, clean the spacer shims with a lint-free cloth and isopropyl alcohol



When mounting the scale with fixing clamps:  
Do not insert the spacer shims near the fixing clamps.

- ▶ Use the spacer shims to set the mounting clearance
- ▶ Lightly tighten the screws on the scanning head
- ▶ Remove the spacer shims individually

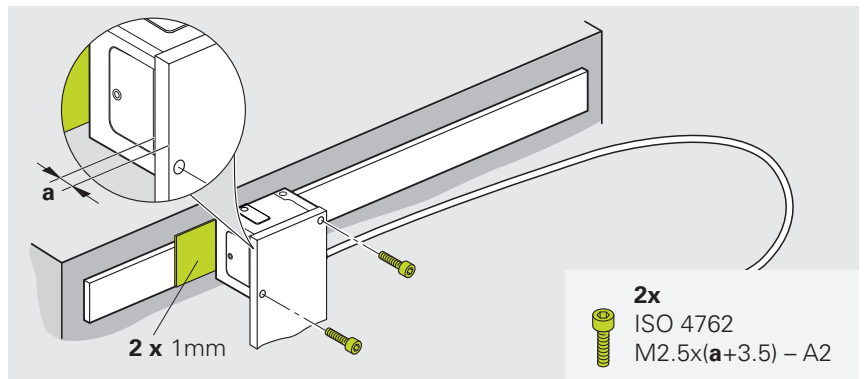

**Next step:** "Adjustment and diagnosis", Page 32

### 4.3.3 Variant: Mounting with the holder at top

The mounting variant described in this chapter refers to mounting of the scanning head with the holder at top.

An overview of the mounting variants is provided on Page 27.

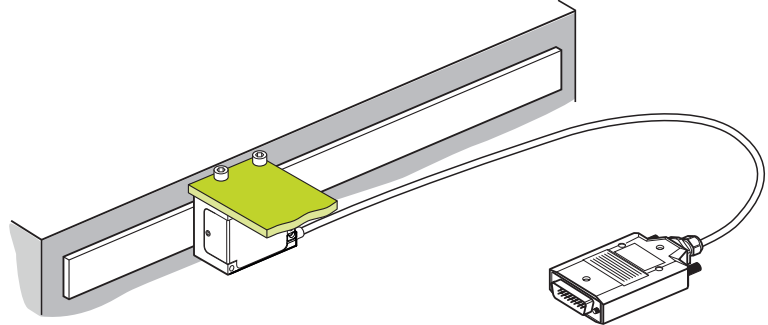

#### Notes on mounting the scanning head with the holder at top

**i** The tightening torques of the mounting screws are only valid for mounting on steel.

#### NOTICE

##### Property damage due to unsuitable cleaning agents!

- ▶ Use only isopropyl alcohol to clean the encoder
  - ▶ Clean the encoder with a lint-free cloth
- ▶ If necessary, clean the graduation and the scanning head with a lint-free cloth and isopropyl alcohol

Pay attention to the mounting dimensions. Deviations from the mounting dimensions lead to imprecise measurement results during operation.

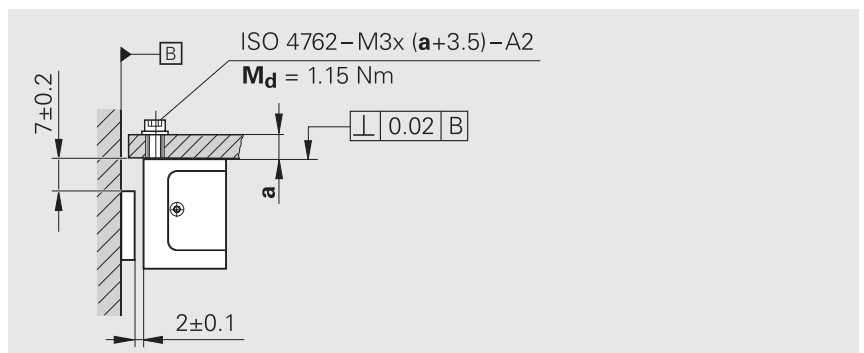
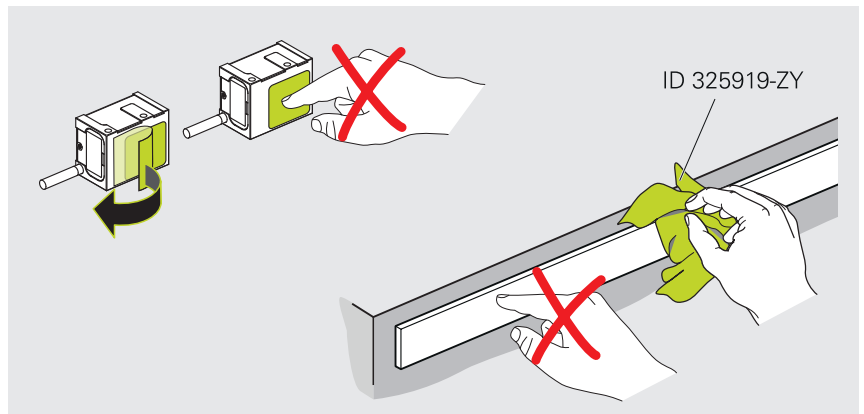

### Materials and tools

For this task, the following materials and tools are needed:

#### Included in delivery

- Spacer shims

#### To be provided separately

- 2 screws (ISO 4762 – M3x(a+3.5))
- Torque wrench (hexagon socket for 2.5 mm)

### Mounting the scanning head

- ▶ Remove the protective film from the scanning head
- ▶ If necessary, remove the protective film from the scale

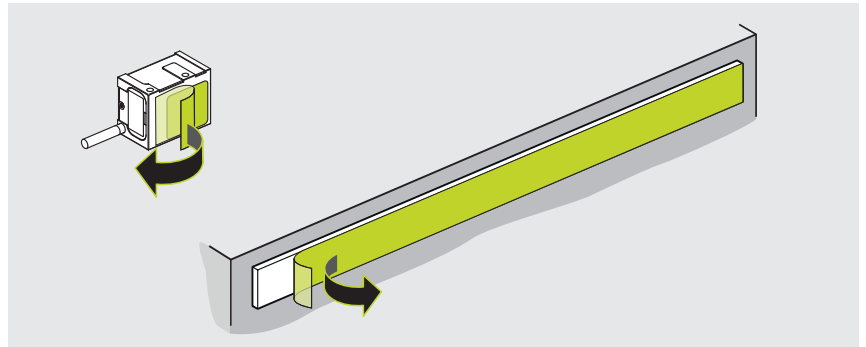

- ▶ If necessary, clean the spacer shims with a lint-free cloth and isopropyl alcohol

**i** When mounting the scale with fixing clamps:  
Do not insert the spacer shims near the fixing clamps.

- ▶ Use the spacer shims to set the mounting clearance
- ▶ Lightly tighten the screws on the scanning head
- ▶ Remove the spacer shims individually

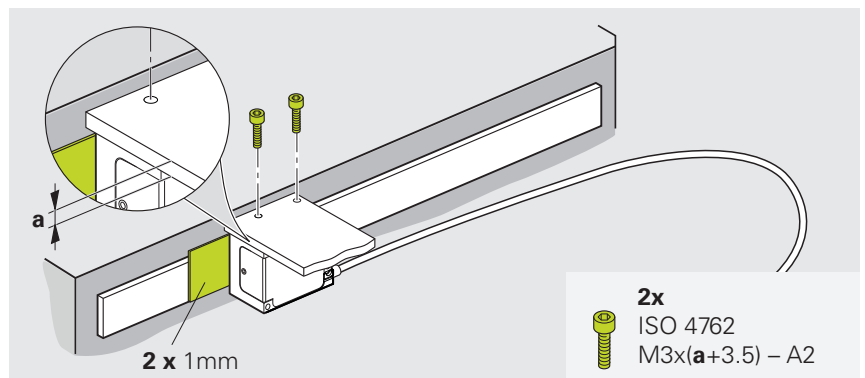

**Next step:** "Adjustment and diagnosis", Page 32

## 5 Adjustment and diagnosis

This chapter describes the continuity test, as well as the adjustment and diagnosis with the PWM 21 and the Adjusting and Testing Software (ATS).

### 5.1 Requirements and notes

The following components are needed for the adjustment and diagnosis of HEIDENHAIN encoders:

- PWM 21
- ATS – if a special version (SVxx.x.x) for a specific device is available, use the special version. If no special version is available, use the latest version (Vx.x.xx).



The ATS is available for download free of charge.

- ▶ [www.heidenhain.com/service/downloads/software/](http://www.heidenhain.com/service/downloads/software/)
- ▶ Open the **Categories** selection menu
- ▶ Select the **Inspection and testing devices** category



For more information, refer to the applicable **Adjusting and Testing Software** documentation.

- ▶ [www.heidenhain.com/documentation](http://www.heidenhain.com/documentation)
- ▶ Enter the document ID **543734**



For more information, see the **Exposed Linear Encoders** brochure.

- ▶ [www.heidenhain.com/documentation](http://www.heidenhain.com/documentation)
- ▶ Enter the document ID **208960**

### 5.2 Continuity check

#### 5.2.1 Materials and tools

For this mounting step, the following materials and tools are needed:

##### Included in delivery

##### To be provided separately

- Resistance measuring device

#### 5.2.2 Measuring the electrical resistance

- ▶ Check the electrical resistance between the connector housing and the machine



The electrical resistance between the connector housing and the machine must be  $< 1 \Omega$ .

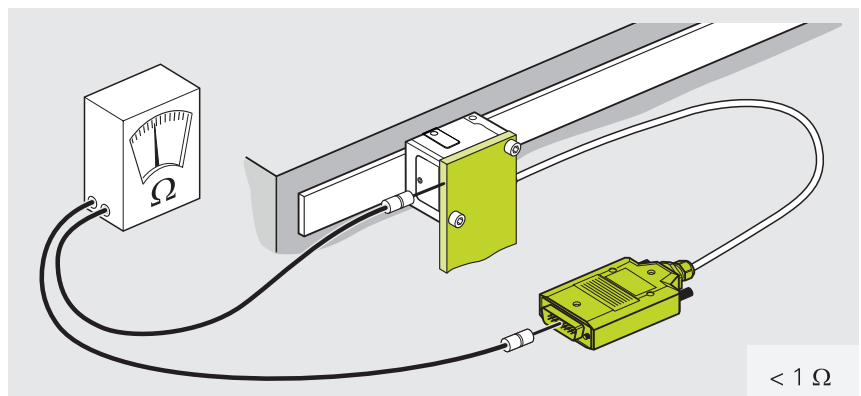

## 5.3 Connecting the encoder to the ATS

### 5.3.1 Connecting the encoder

- ▶ Connect the encoder to the PWM 21
- ▶ Switch on the PWM 21

### 5.3.2 Selecting the connection

---

#### Connection options

| Connecting the encoder using its ID  | Connecting the encoder manually   |
|--|---|
| Recommended option with automatic determination of the measuring parameters.<br><b>Page 34</b> | Alternative option if the encoder cannot be connected using its ID.<br><b>Page 36</b> |

### 5.3.3 Connecting the encoder using its ID

#### ⚠ WARNING

##### Risk of injury from laser radiation!

Class 3B laser exposure causes serious eye and skin injuries.

- ▶ Mount the scanning head correctly
- ▶ Wear eye protection, protective clothing and protective gloves
- ▶ Never stare into the laser beam or the reflection of the laser beam
- ▶ Do not touch the laser beam
- ▶ Shield the laser beam
- ▶ Structurally prevent reflections of the laser beam

- ▶ Double-click **Connect the encoder** in the function menu
- ▶ The **Encoder selection** dialog opens

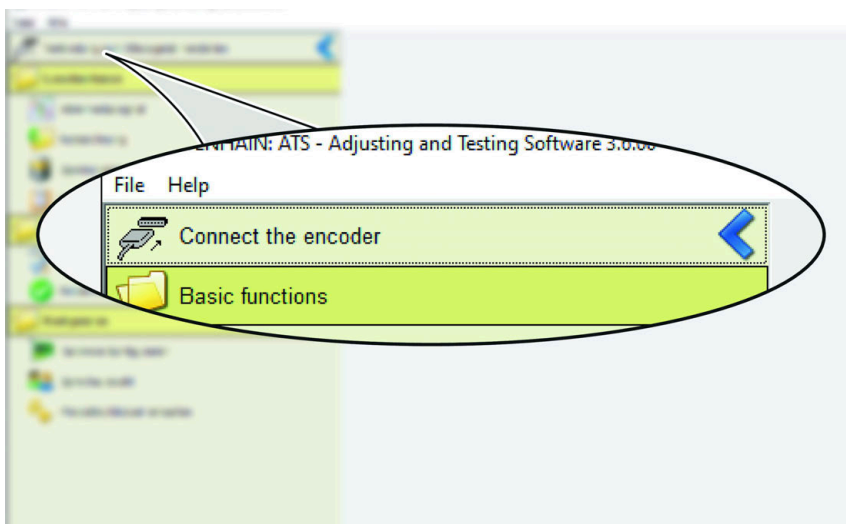

Function menu

- ▶ Enter the product ID of the scanning head in the **ID number** field
- ▶ The determined encoder parameters are shown in the **Encoder data** field.
- ▶ Click **Connect**
- ▶ The connection to the encoder is established.
- ▶ The **Function menu** opens.

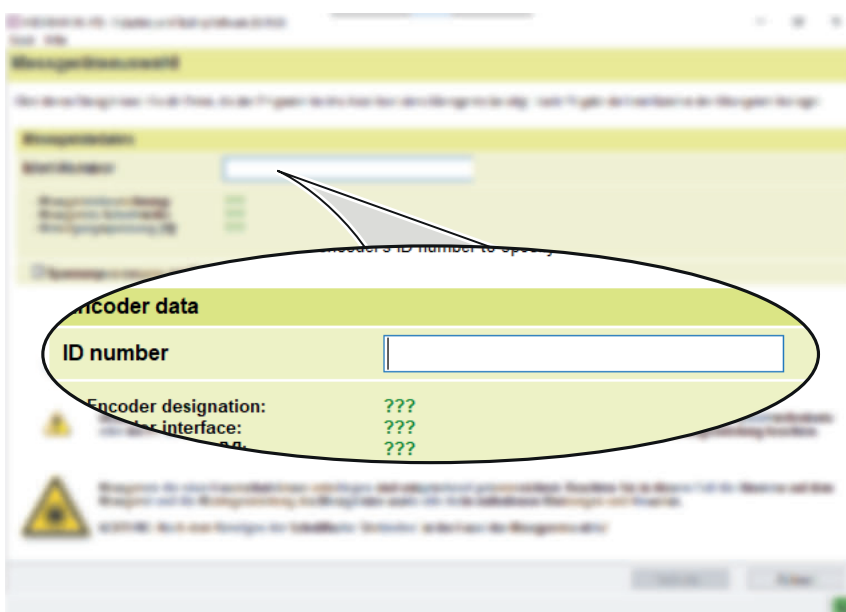

Encoder selection dialog



If you cannot connect the encoder using its ID, proceed as described in the "**Connecting the encoder manually**" chapter.

**Next step:** "Selecting the scanning head", Page 39

### 5.3.4 Connecting the encoder manually

- ▶ Double-click **Connect the encoder** in the function menu
- ▶ The **Encoder selection** dialog opens.

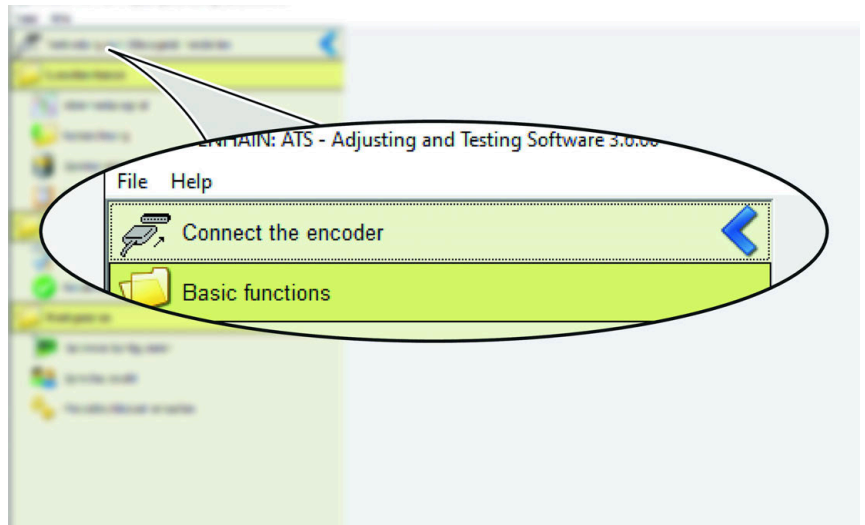

Function menu

- ▶ Click **Manual Settings**
- ▶ The **Encoder selection** dialog opens.

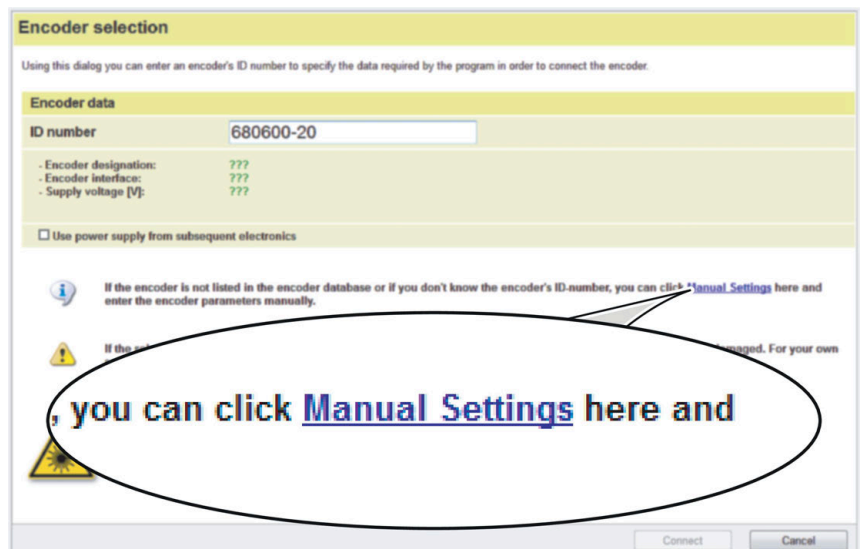

Encoder selection dialog

- ▶ Follow the safety instructions
- ▶ Click **Next**
- ▶ The **Encoder selection** dialog opens.

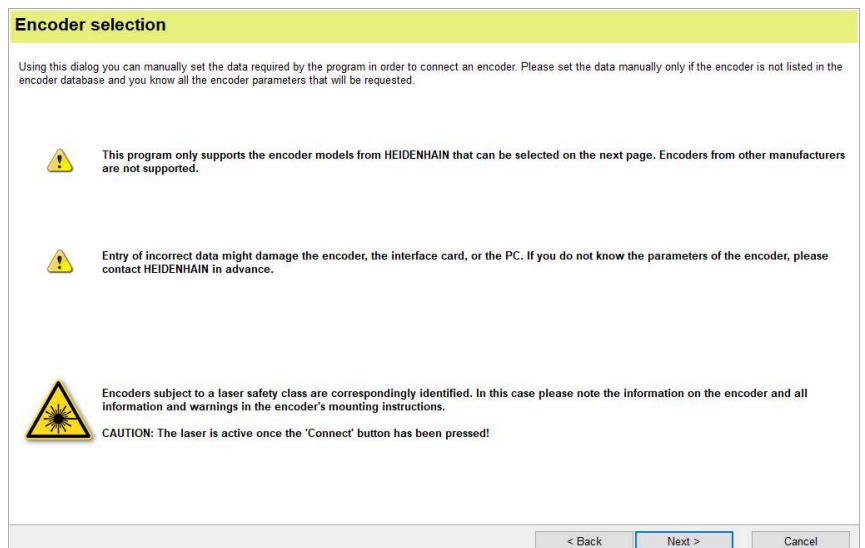

Encoder selection dialog



For more information on the supply voltage and interfaces, refer to the **Exposed Linear Encoders** brochure.

- ▶ [www.heidenhain.com/documentation](http://www.heidenhain.com/documentation)
- ▶ Enter the document ID **208960**

- ▶ Select the permissible encoder supply voltage in the **Encoder supply voltage** section
- ▶ To activate voltage readjustment by the PWM, select the **Adjust voltage over sensor lines**
- ▶ Select the interface type in the **Encoder interface** section
- ▶ If the EnDat 3 interface is selected, the mounting code is entered automatically. Continue with the step "Click **Connect**."
- ▶ Click **Mounting code**
- ▶ The **Entry of ATS code** message appears.

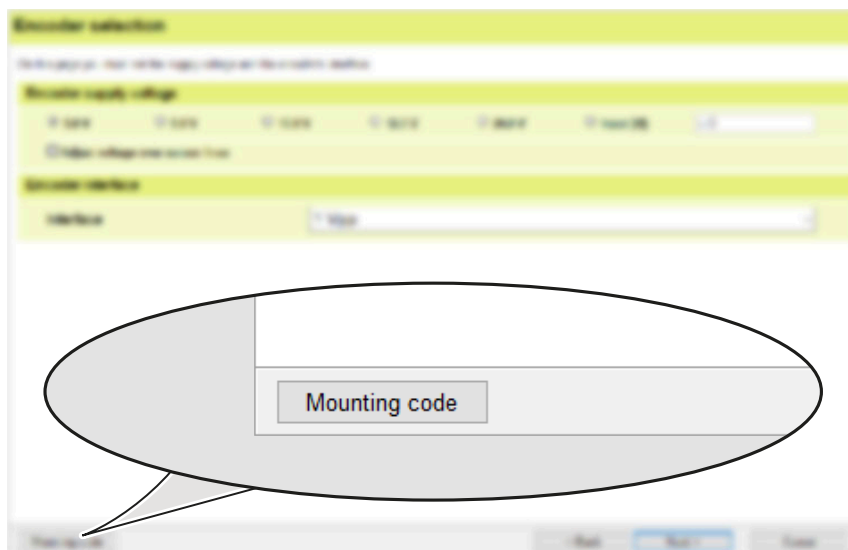

Encoder selection dialog

- ▶ Click **OK**
- ▶ The **Encoder selection** dialog with the mounting code opens.

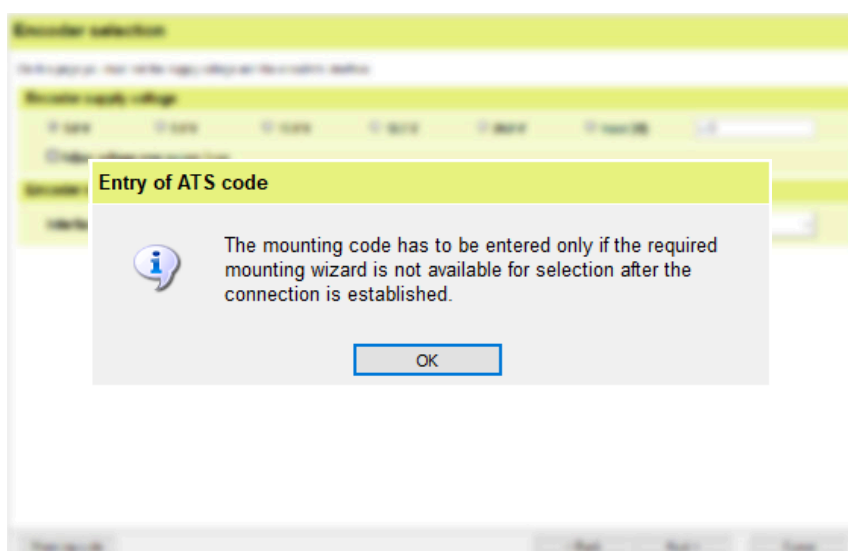

The **Entry of ATS code** note

- ▶ For the **Mounting code**, enter the value:  
LIP 28: I004-A003 LIP 21: E001-A007  
LIP 29: E002-A007
- ▶ Click **Next**
- ▶ The **Encoder selection** dialog with the encoder data opens.

Encoder selection dialog with the mounting code

## NOTICE

### Property damage due to incorrect data settings!

Incorrect data settings can cause damage to the interface card or the PC.

- ▶ Before connecting the encoder, check the encoder data

|                     |           |                   |
|---------------------|-----------|-------------------|
| Encoder interface:  | EnDat22   | 1 V <sub>PP</sub> |
| Supply voltage [V]: | 3.6 to 14 | 5.0               |
| Voltage adjustment: | Yes       | Yes               |

- ▶ Click **Connect**
- ▶ The connection to the encoder is established.
- ▶ The **Function menu** opens.

The **Encoder selection** dialog with the encoder data

**Next step:** "Selecting the scanning head", Page 39

## 5.4 Adjusting the scanning head

### 5.4.1 Selecting the scanning head

| Scanning head variants  |  |
|---|--|
| LIP 21, LIP 29  | LIP 28   |
| Scanning heads with EnDat 2.2, Fanuc, or Mitsubishi interface<br><b>Page 40</b> | Scanning head with 1 V <sub>PP</sub> interface<br><b>Page 45</b> |

## 5.4.2 Mounting the LIP 21 or LIP 29 scanning head

### Using the mounting wizard

- ▶ Double-click **Mounting**
- ▶ The **Mounting wizard** opens.
- ▶ The **Laser class 3B** caution appears.

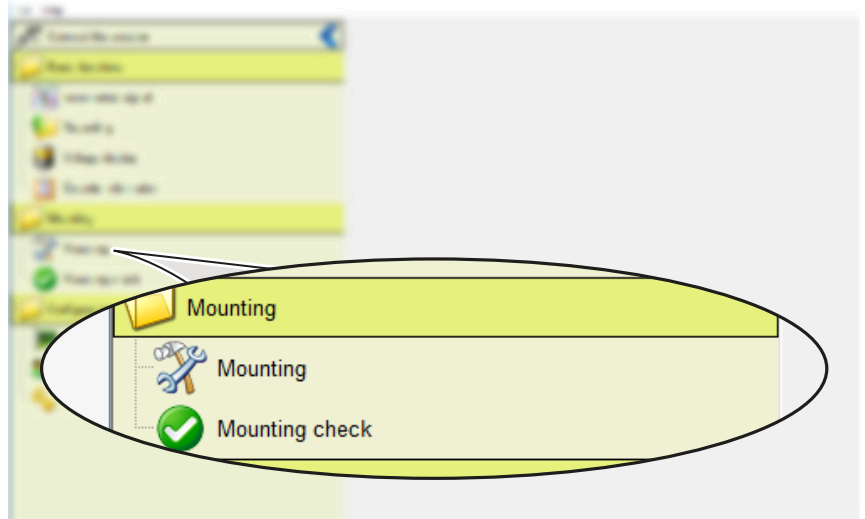

Function menu

- ▶ Observe the messages
- ▶ Click **Next**
- ▶ The **Step 1 Mounting the encoder** dialog opens.

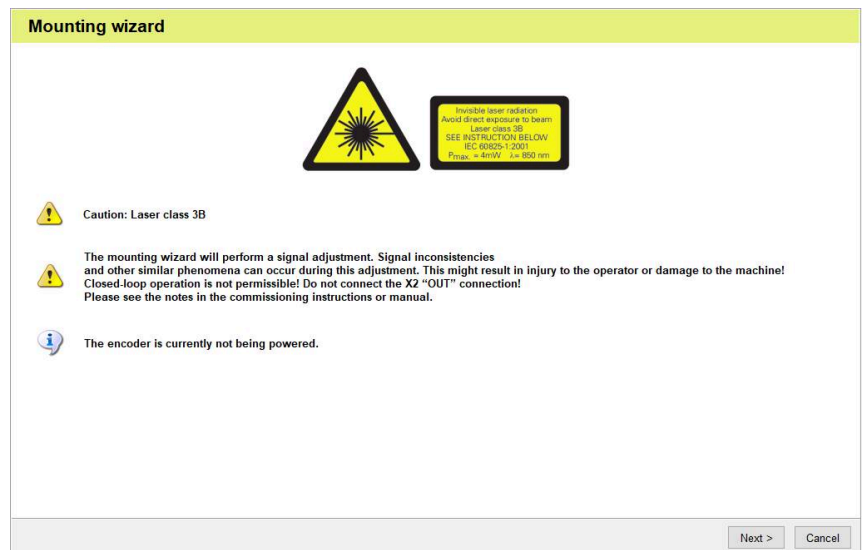

The **Laser class 3B** warning

- ▶ Optionally, click **Settings**
- ▶ The **Settings** dialog opens.

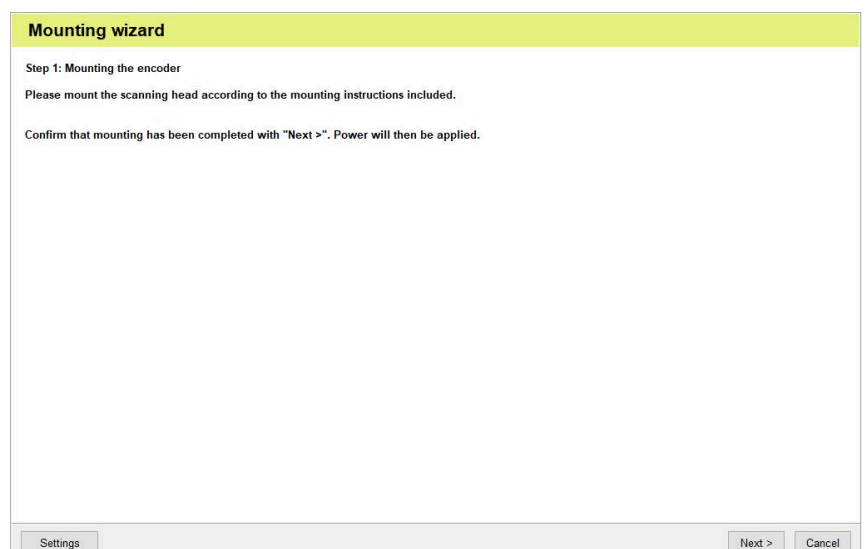

The **Step 1: Mounting the encoder** dialog

**i** If **Adjustment of reference-mark signal** is selected, the reference-mark signal is adjusted. If there is no reference mark on the encoder, deselect this function.

- ▶ Deselect **Adjustment of reference-mark signal** as needed
- ▶ Click **OK**
- ▶ The **Step 1 Mounting the encoder** dialog opens.

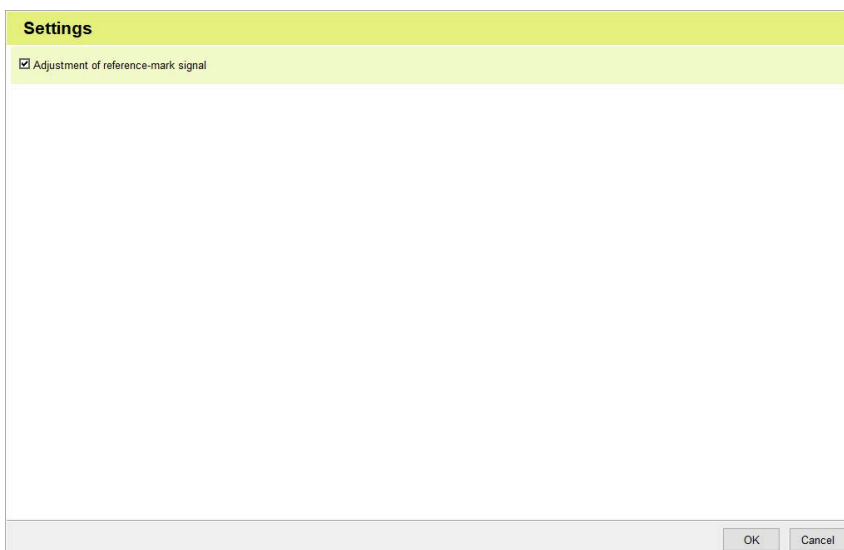

The **Settings** dialog

- ▶ Click **Next**
- ▶ The **Restore factory settings** message appears

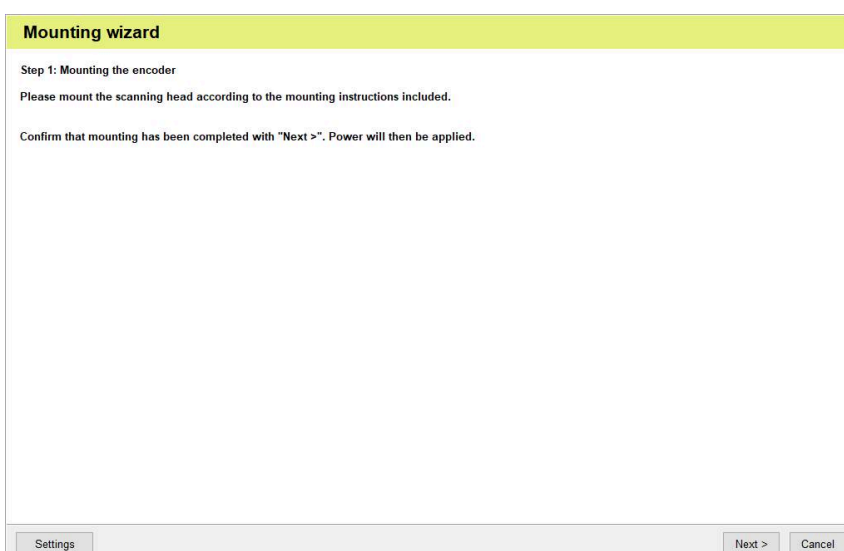

The **Step 1: Mounting the encoder** dialog

- ▶ Click **OK**
- ▶ The **Step 2: Adjust the scanning gap** dialog opens.
- ▶ The encoder was reset to the factory default setting.

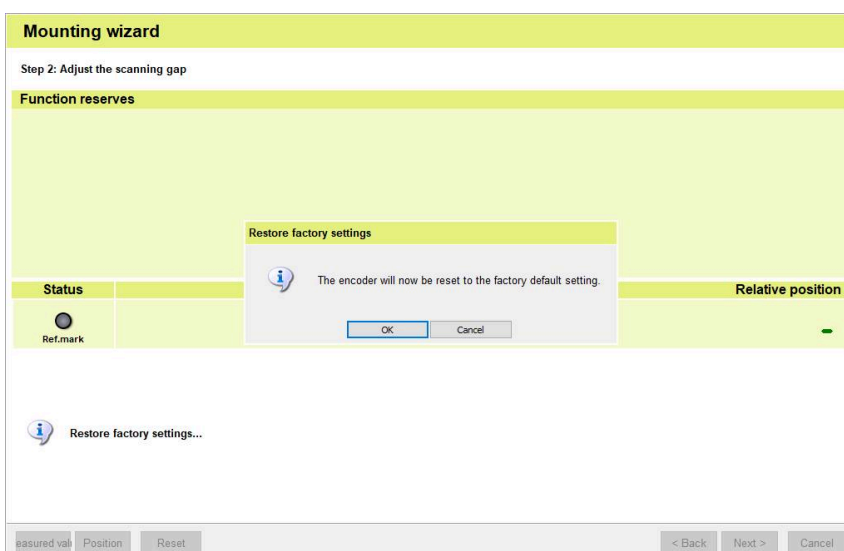

The **Restore factory settings** message

Perform Moiré alignment.

- ▶ Align the scanning head so that the black bar is as far to the right as possible



- Perform the alignment at standstill
- Do not perform the alignment at the reference mark

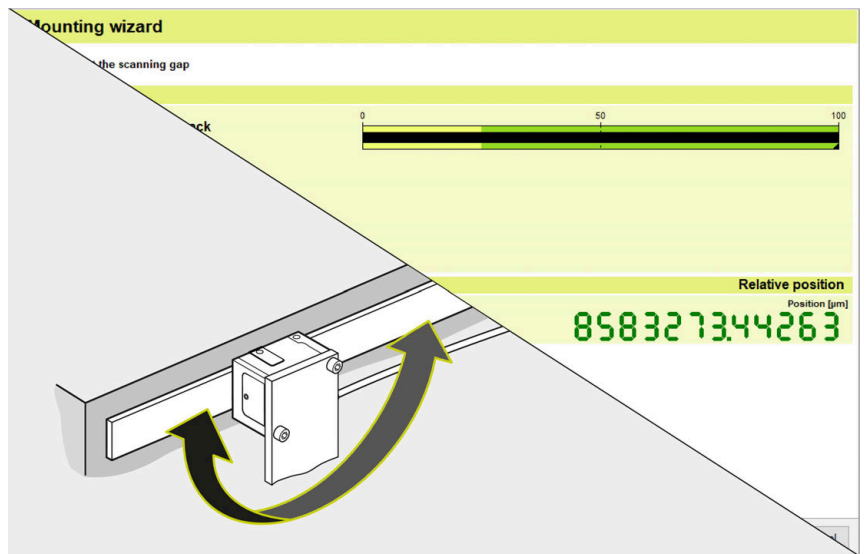

Moiré alignment

- ▶ Tighten the screws with the specified torque
- ▶ Click **Next**
- ▶ The **Step 3: Adjusting main track and reference signal** dialog opens.

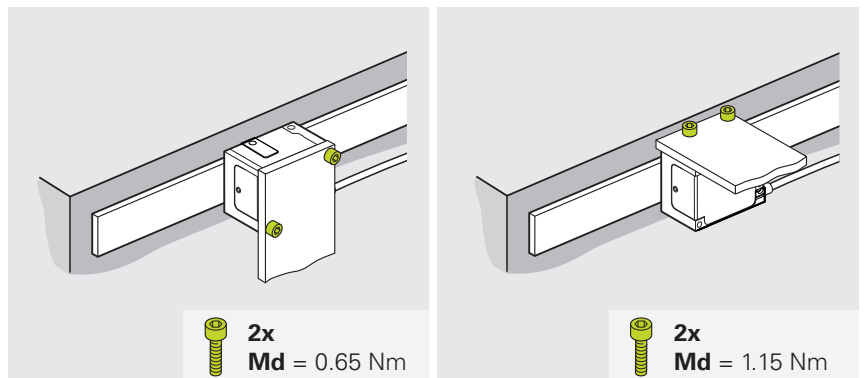

- ▶ Traverse the reference mark in both directions until "Progress: 100%" has been reached
- ▶ The reference mark and the incremental track have now been adjusted.
- ▶ The adjustment values are saved permanently in the encoder.

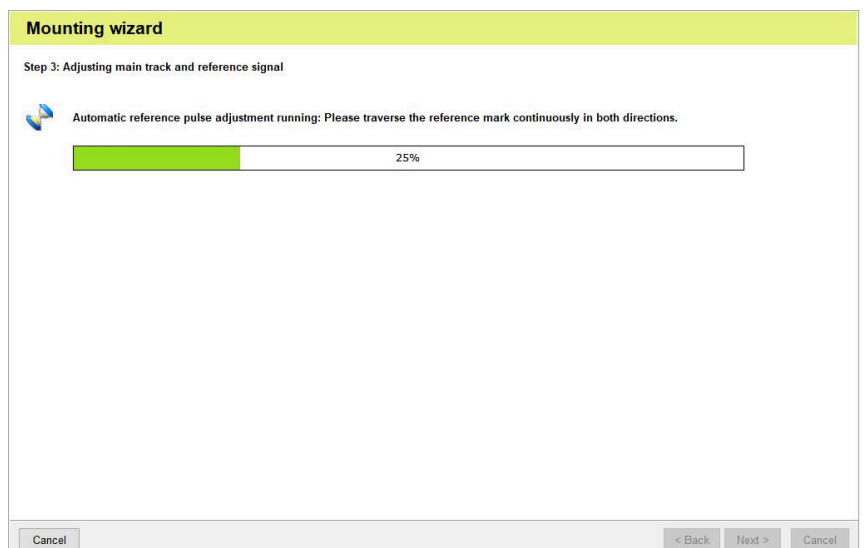

The **Step 3: Adjusting main track and reference signal** dialog

- ▶ Click **Next**
- > The **Step 4: Verify mounting** dialog opens.

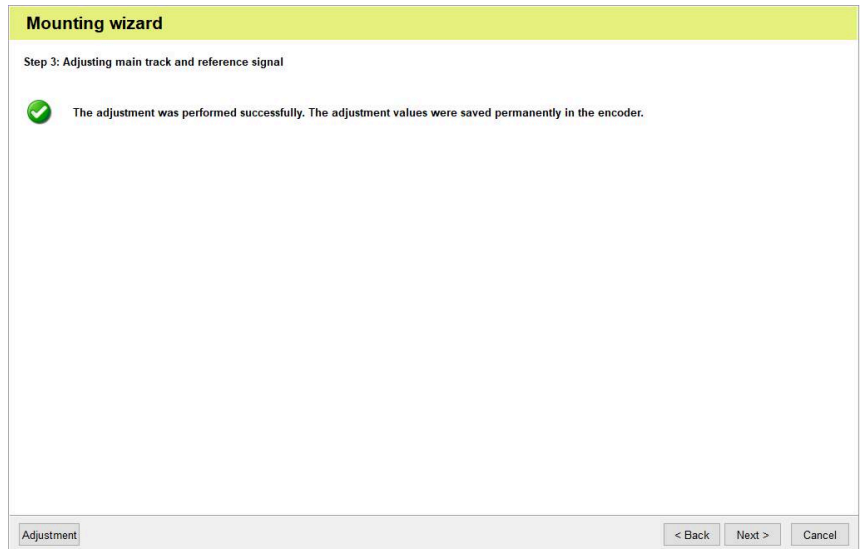

The **Adjustment was performed successfully** message

- ▶ Traverse the scanning head at 10 mm/s
- ▶ Check the values
- ▶ Click **Next**
- > The mounting wizard restarts with **Step 1: Mounting the encoder**.
- ▶ Click **End**
- > The **mounting wizard** closes.

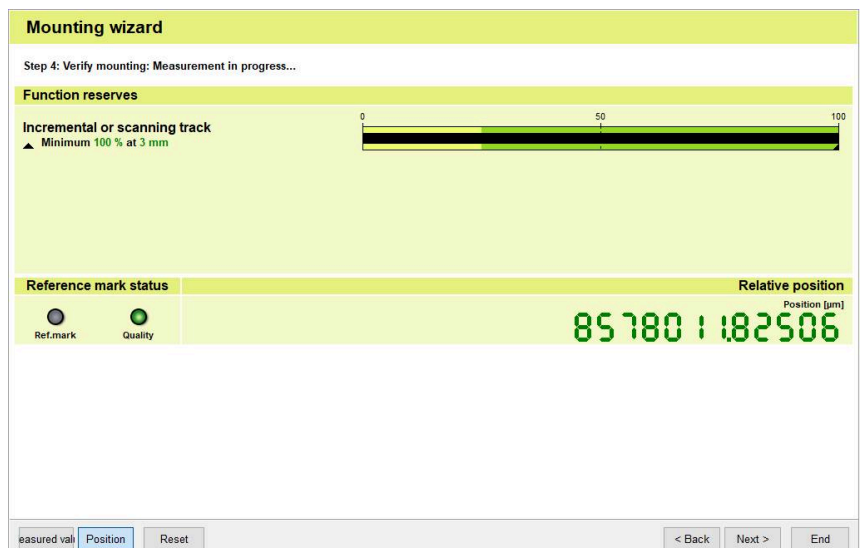

The **Step 4: Verify mounting** dialog

### Checking the mounting

- ▶ Double-click **Mounting check**
- > The **Mounting inspection** dialog with the **Laser class 3B** warning appears.

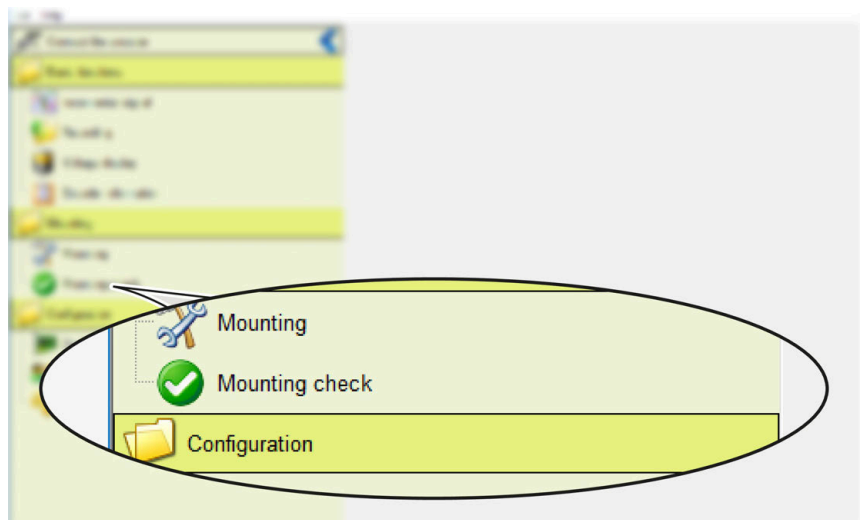

Function menu

- ▶ Click **Next**
- ▶ The **Verify mounting: Measurement in progress...** dialog appears.

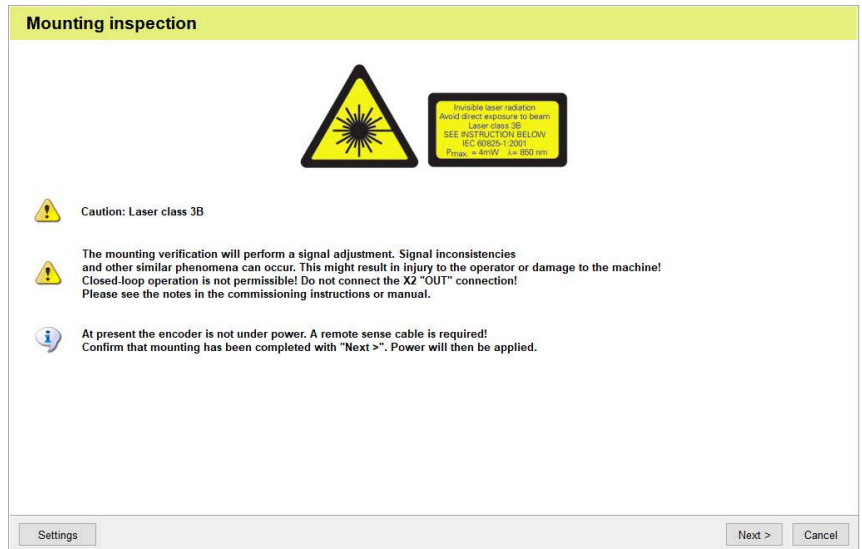

The **Mounting inspection** dialog with the **Laser class 3B** caution

- ▶ Traverse the scanning head at 10 mm/s
- ▶ Check the values
- ▶ Click **End**
- ▶ **Mounting inspection** is completed.

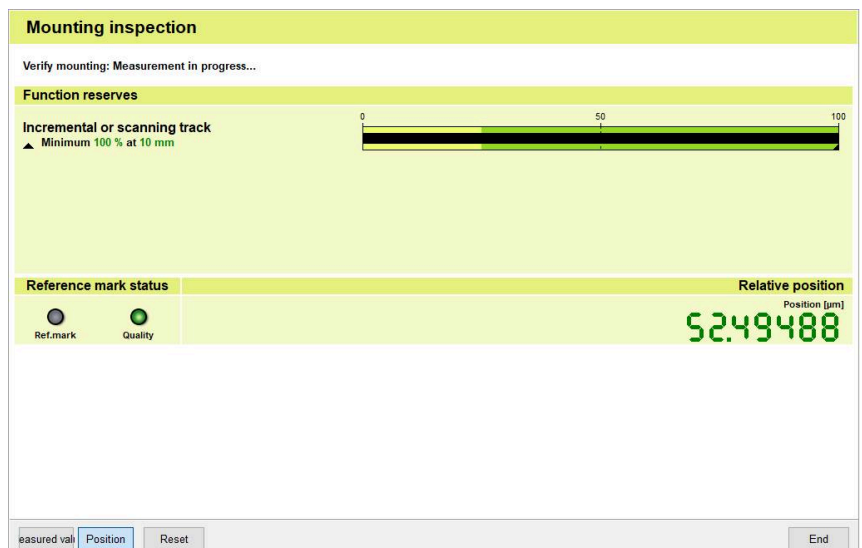

The **Mounting inspection: Measurement in progress...** dialog

**Next step:** "Final steps", Page 51

### 5.4.3 Mounting the LIP 28 scanning head

#### Using the mounting wizard

- ▶ Double-click **Mounting**
- > The **Mounting wizard** opens.
- > The **Laser class 3B** caution appears.

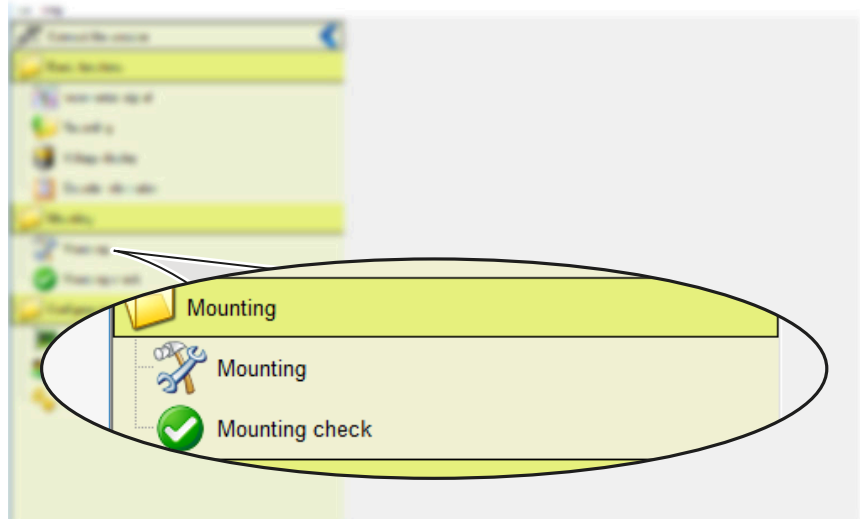

Function menu

- ▶ Observe the messages
- ▶ Click **Next**
- > The **Step 1 Mounting the encoder** dialog opens.

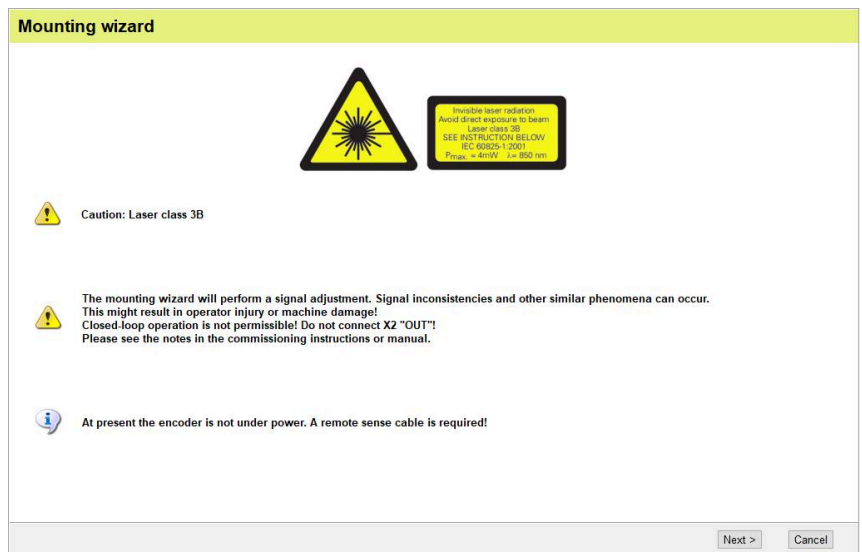

The **Laser class 3B** warning

- ▶ Optionally, click **Settings**
- > The **Settings** dialog opens.

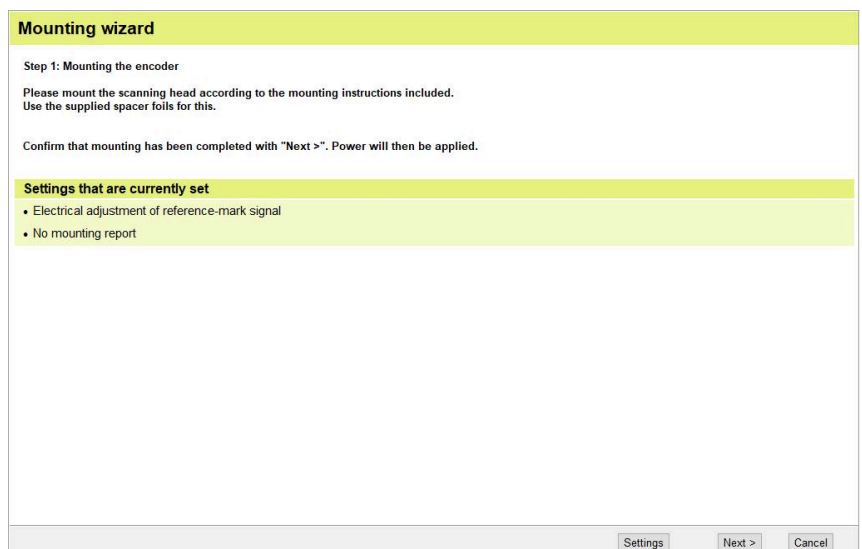

The **Step 1: Mounting the encoder** dialog

**i** If **Adjustment of reference-mark signal** is selected, the reference-mark signal is adjusted. If there is no reference mark on the encoder, deselect this function.

- ▶ Deselect **Adjustment of reference-mark signal** as needed

**i** The **Report functionality** generates a report in .json format. This report is stored in the root directory of the project.

- ▶ Select the **Report functionality**, if required
- ▶ Click **OK**
- ▶ The **Step 1: Mounting the encoder** dialog opens.
- ▶ Click **Next**
- ▶ The **Mounting wizard** message appears

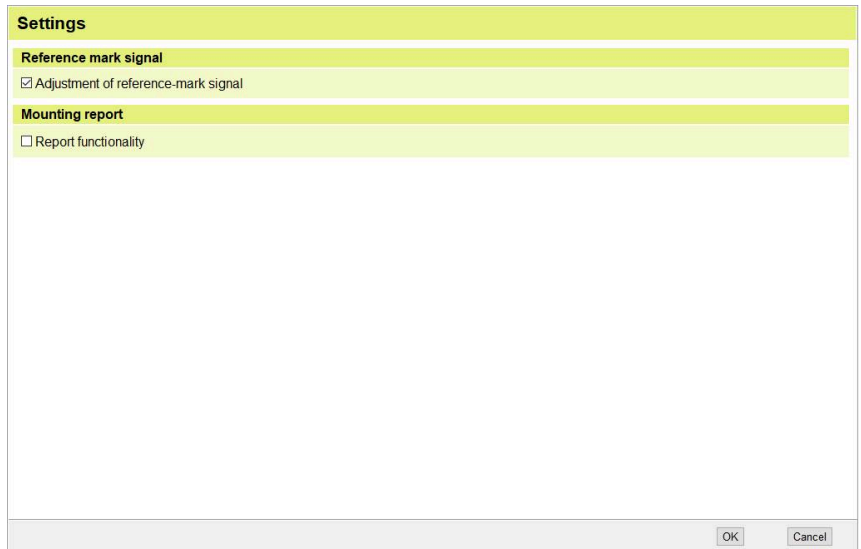

The **Settings** dialog

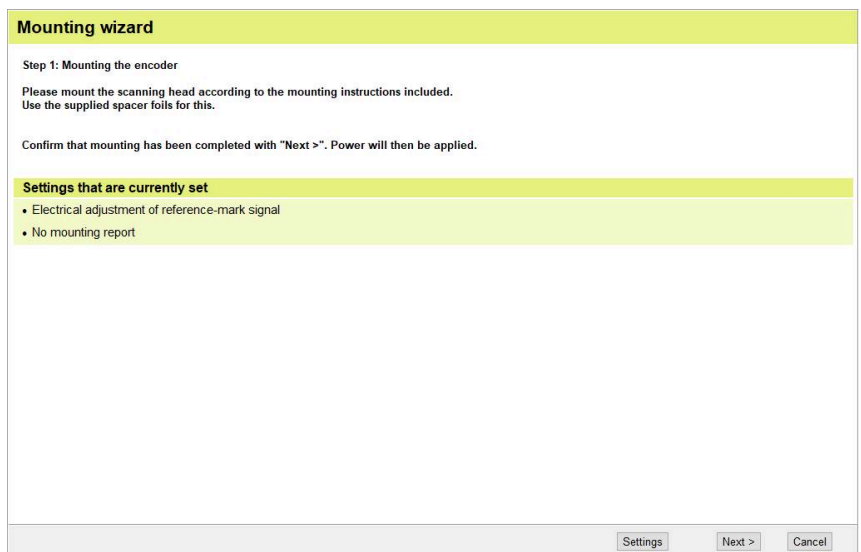

The **Step 1: Mounting the encoder** dialog

- ▶ Click **OK**
- ▶ The **Step 2: Mechanical mounting** dialog opens.
- ▶ The encoder was reset to the factory default setting.

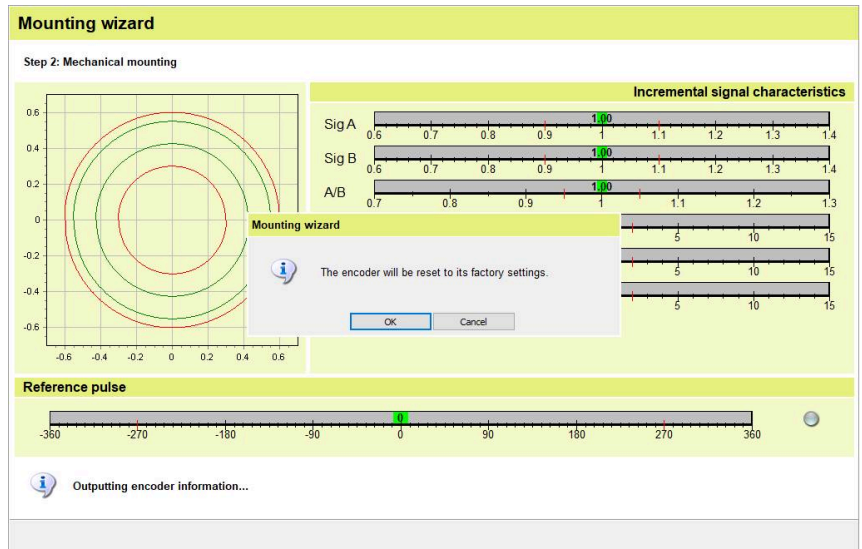

The **Encoder will be reset to its factory settings** message

Perform Moiré alignment.

- ▶ Rotate the scanning head to set the maximum possible signal (Sig A, Sig B)

**i**

- Perform the alignment at standstill
- Do not perform the alignment at the reference mark

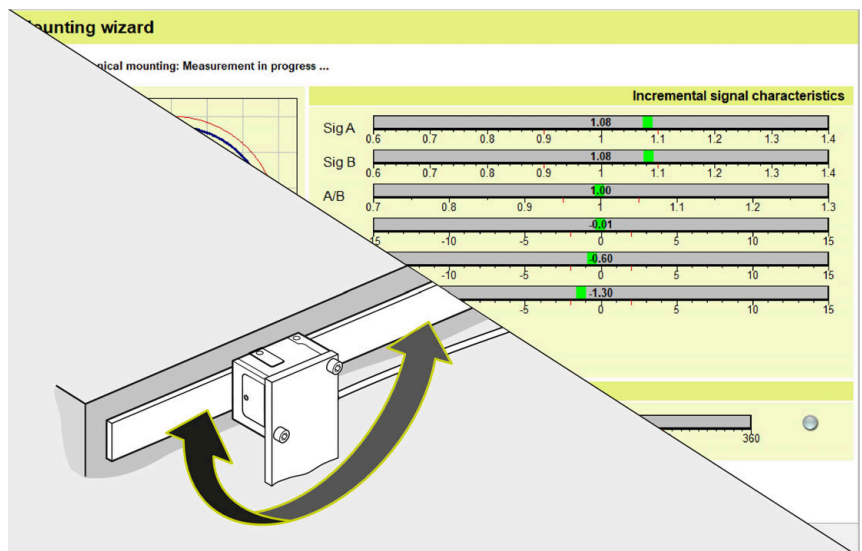

Moiré alignment

- ▶ Traverse the scanning head at 10 mm/s
- ▶ Make sure that the blue circle is within the limit values.

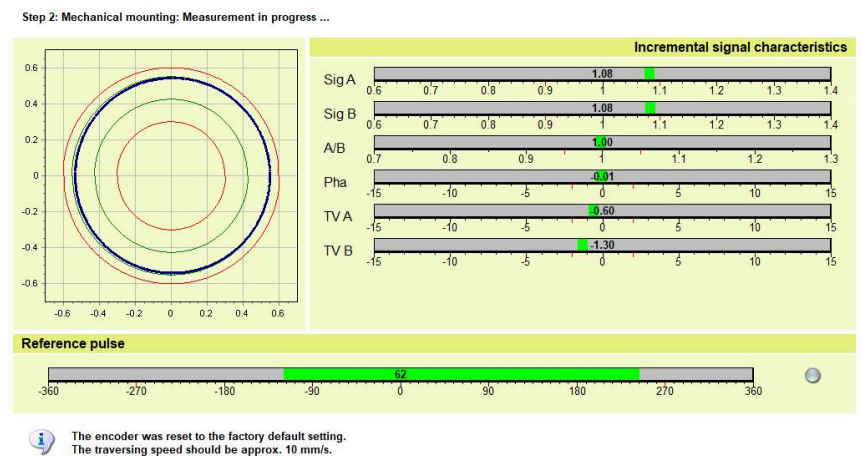

The **Step 2: Mechanical mounting: Measurement in progress ...** dialog

- ▶ Tighten the screws with the specified torque
- ▶ Click **Next**
- ▶ The **Step 3: Adjusting the incremental signals and the reference pulse ...** dialog opens.

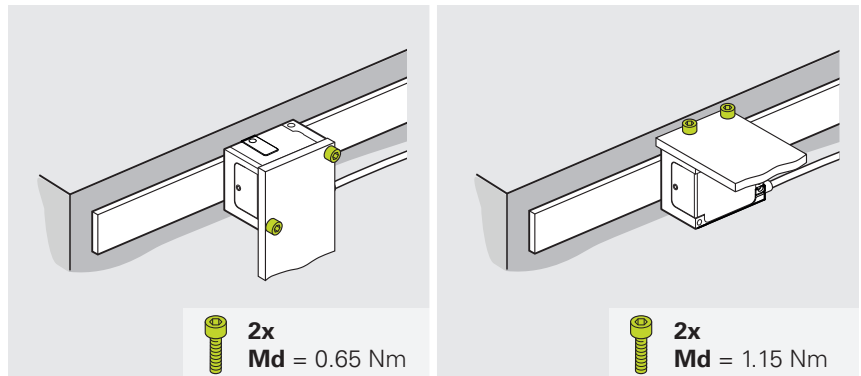

- ▶ Traverse the reference mark in both directions until "Progress: 100%" has been reached
- ▶ The reference mark and the incremental track have now been adjusted.
- ▶ The adjustment values are saved permanently in the encoder.

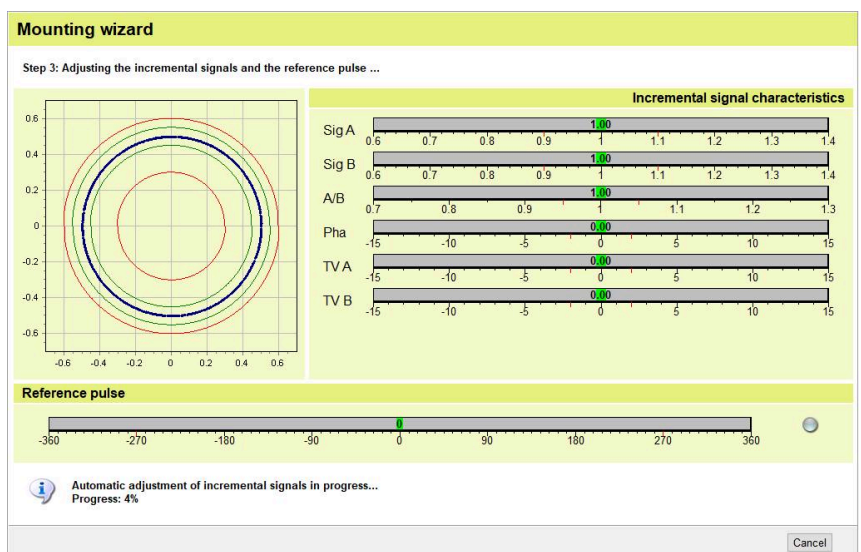

The **Step 3: Adjusting the incremental signals and the reference pulse ...** dialog

- ▶ Click **Next**
- ▶ The **Step 4: Verify mounting** dialog opens.

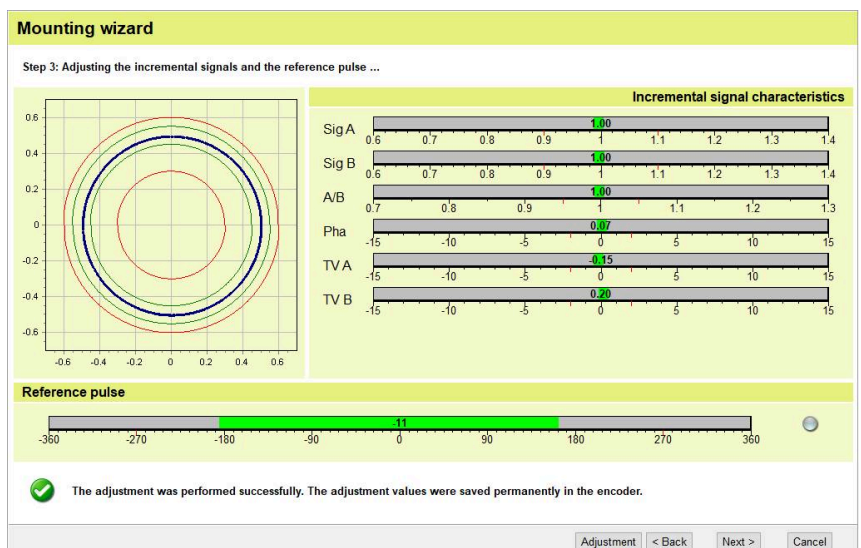

The **Adjustment was performed successfully** message

- ▶ Traverse the scanning head at 10 mm/s
- ▶ Check the values
- ▶ Click **New mounting**
- ▶ The mounting wizard restarts with **Step 1: Mounting the encoder**.
- ▶ Click **Exit**
- ▶ The **mounting wizard** closes.

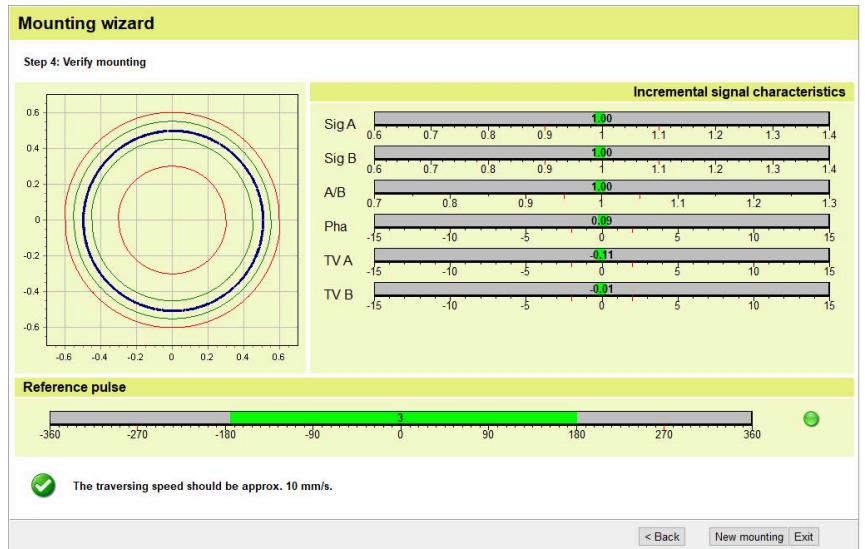
The **Step 4: Verify mounting** dialog

### Verifying the mounting

- ▶ Double-click **Mounting check**
- ▶ The **Mounting inspection** function opens and displays a message.

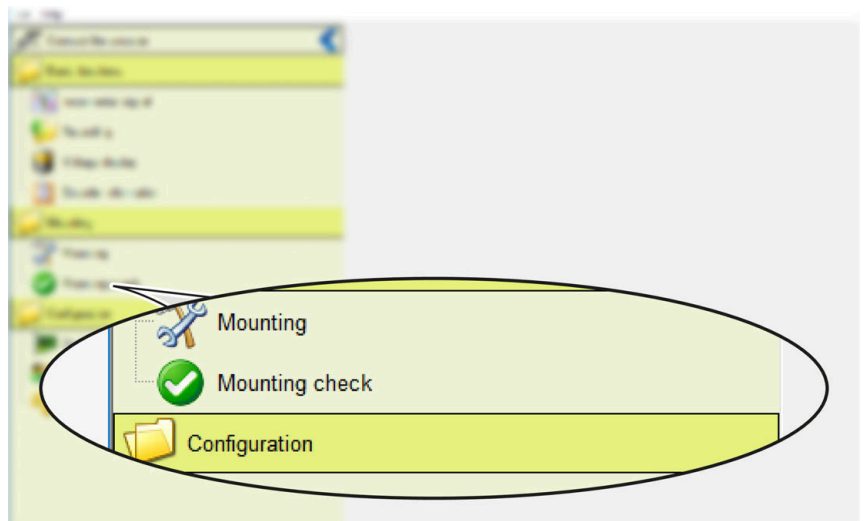

Function menu

- ▶ Click **Next**
- ▶ The **Mounting inspection** function opens and displays a message about the **traversing speed**.

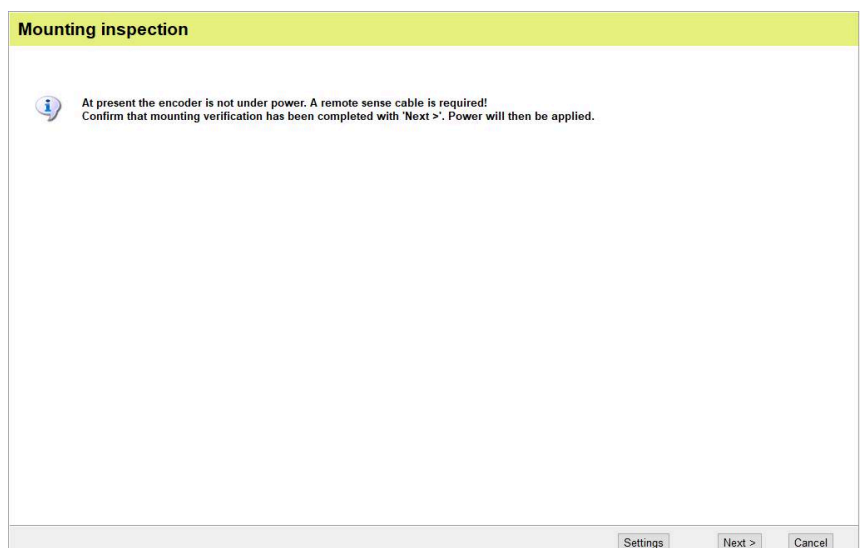
The **Mounting inspection** dialog with a message

- ▶ Traverse the scanning head at 10 mm/s
- ▶ Check the values
- ▶ Click **Exit**
- ▶ The **Mounting inspection** function closes.

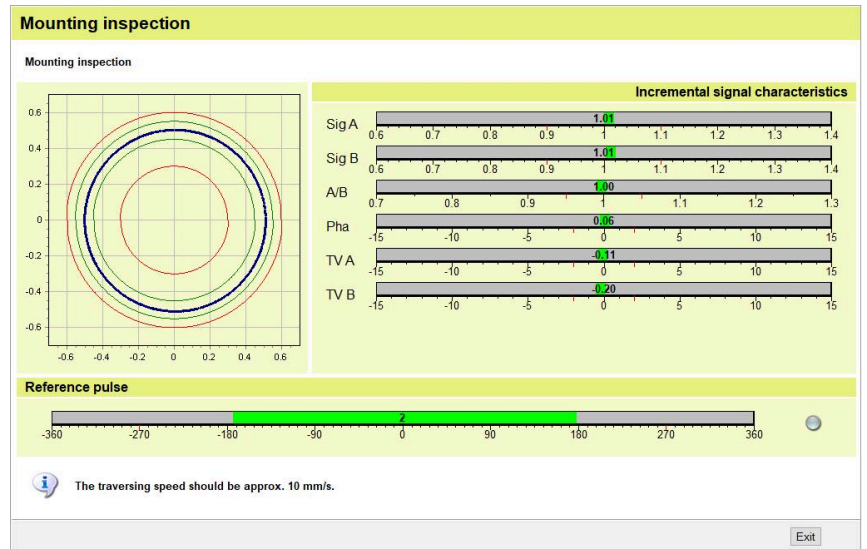

The **Mounting inspection** dialog with the **Traversing speed...** message

**Next step:** "Final steps", Page 51

## 6 Final steps

### 6.1 Connecting the encoder to the downstream electronics

#### **WARNING**

##### **Danger of electric shock due to plug connections under voltage!**

Connecting and disconnecting live cables and plug connections in the equipment can result in death or serious injury.

- Only connect and disconnect cables and plug connections when no current is flowing through them
- Disconnect the downstream electronics from power before connecting the product
- For cables without connectors, pay attention to the pin layout

- ▶ Connect the encoder to the downstream electronics

#### **NOTICE**

##### **Property damage resulting from incorrect routing of the connecting cable!**

Connecting cables may become damaged as a result of incorrect routing.

- ▶ Observe the maximum permissible bend radii
- ▶ Do not cross connecting cables in drag chains
- ▶ Route connecting cables professionally



For more information on the cable characteristics and cable routing, refer to the **Cables and Connectors** brochure.

- ▶ [www.heidenhain.com/documentation](http://www.heidenhain.com/documentation)
- ▶ Enter the document ID **1206103**



For more information on the pin layouts of pre-assembled cables, refer to the **Cables and Connectors** brochure.

- ▶ [www.heidenhain.com/documentation](http://www.heidenhain.com/documentation)
- ▶ Enter the document ID **1206103**



For more information on sources of interference, refer to the **Interfaces of HEIDENHAIN Encoders** brochure.

- ▶ [www.heidenhain.com/documentation](http://www.heidenhain.com/documentation)
- ▶ Enter the document ID **1078628**

## 7 Removal

This chapter describes the disassembly of the product.

### 7.1 Safety precautions regarding removal

#### WARNING

##### **Live plug connections!**

If you disengage plug connections while the equipment is under power, this may result in fatal accidents or severe personal injury.

- ▶ Do not engage or disengage any connecting elements while the product is under power

#### WARNING

##### **Moving machine parts!**

Risk of injury due to moving machine parts depending on the installation location and the application

- ▶ Observe all of the machine manufacturer's notes on working on the machine (e.g., always disconnect the machine from the power supply)

#### CAUTION

##### **Fragile carrier material of the scale unit or the scale itself!**

Risk of injury from splinters and sharp edges of the carrier material

- ▶ Wear protective gloves and safety goggles
- ▶ Do not bend or deform the scale unit or scale excessively

### 7.2 Removing the scanning head

- ▶ Remove the scanning head in the reversed sequence of mounting.  
**Further information:** "Mounting the scanning head", Page 27

### 7.3 Removing the scale



Further information can be found in the **Disassembly Instructions**.

- ▶ [www.heidenhain.com/documentation](http://www.heidenhain.com/documentation)
- ▶ Enter the document ID **1185755**

# HEIDENHAIN

## DR. JOHANNES HEIDENHAIN GmbH

Dr.-Johannes-Heidenhain-Straße 5

**83301 Traunreut, Germany**

☎ +49 8669 31-0

☒ +49 8669 32-5061

info@heidenhain.de

**Technical support** ☒ +49 8669 32-1000

**Measuring systems** ☎ +49 8669 31-3104

service.ms-support@heidenhain.de

**NC support** ☎ +49 8669 31-3101

service.nc-support@heidenhain.de

**NC programming** ☎ +49 8669 31-3103

service.nc-pgm@heidenhain.de

**PLC programming** ☎ +49 8669 31-3102

service.plc@heidenhain.de

**APP programming** ☎ +49 8669 31-3106

service.app@heidenhain.de

**www.heidenhain.com**