

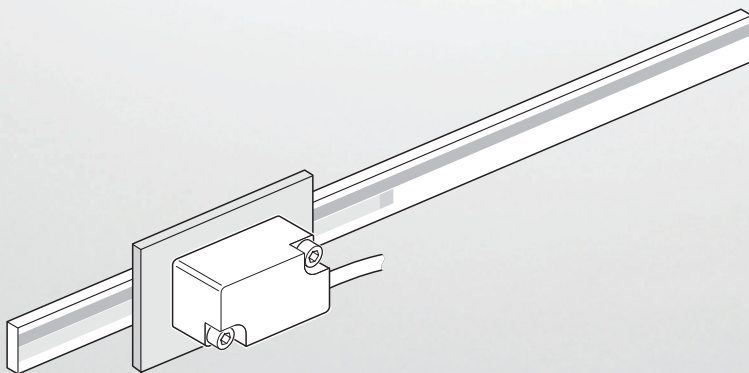

HEIDENHAIN



LIF 471
LIF 481
LIF 471 V
LIF 481 V/U

Mounting Instructions

Table of contents

1	Basic information.....	4
1.1	Applicability of the documentation.....	4
1.2	Target groups of the Mounting Instructions.....	4
1.3	Notes on reading the documentation.....	5
1.4	Symbols and fonts used for marking text.....	6
1.5	Notes in this documentation.....	7
1.6	Units and tolerances.....	7
2	Safety.....	8
2.1	Personnel qualification.....	8
2.2	General safety precautions.....	8
3	Items supplied and accessories.....	10
3.1	Items supplied.....	10
3.1.1	Items supplied: Linear scale.....	10
3.1.2	Items supplied: LIF 47 R, LIF 48 R scanning heads.....	11
3.1.3	Items supplied: LIF 47 V, LIF 48 V, LIF 48 U scanning heads.....	12
3.2	Mounting accessories.....	13
3.2.1	Accessories for mounting the linear scale.....	13
3.2.2	Accessories for mounting the LIF 47 R, LIF 48 R scanning heads.....	14
3.2.3	Accessories for mounting the LIF 47 V, LIF 48 V, LIF 48 U scanning heads.....	15
3.2.4	Accessories for fixed-point bonding.....	15
4	Mounting.....	16
4.1	Requirements and notes.....	16
4.2	Mounting the linear scale.....	17
4.2.1	Choosing the mounting variant.....	17
4.2.2	Variant: Mounting with adhesive film.....	18
4.2.3	Variant: Mounting with fixing clamps.....	22
4.3	Mounting the scanning head.....	27
4.3.1	Selecting the product variant.....	27

4.3.2	Mounting the LIF 47 R, LIF 48 R scanning heads.....	28
4.3.3	Mounting the LIF 47 V, LIF 48 V, LIF 48 U scanning heads.....	30
5	Adjustment and diagnosis.....	33
5.1	Requirements and notes.....	33
5.2	Continuity check.....	33
5.2.1	Materials and tools.....	33
5.2.2	Measuring the electrical resistance.....	33
5.3	Selecting the scanning head.....	34
5.4	Adjustment and diagnosis of LIF 47 R.....	35
5.4.1	Connecting the encoder to the PWT.....	35
5.4.2	Adjusting the scanning head.....	39
5.4.3	Checking the function indicator.....	41
5.4.4	Mounting the limit plates.....	42
5.5	Adjustment and diagnosis of LIF 48 R.....	44
5.5.1	Connecting the encoder to the PWT.....	44
5.5.2	Adjusting the scanning head.....	48
5.5.3	Checking the function indicator.....	51
5.5.4	Mounting the limit plates.....	52
5.6	Adjustment and diagnosis of LIF 47 V.....	54
5.6.1	Connecting the encoder to the PWT.....	54
5.6.2	Adjusting the scanning head.....	58
5.6.3	Mounting the limit plates.....	60
5.7	Adjustment and diagnosis of LIF 48 V, LIF 48 U.....	62
5.7.1	Connecting the encoder to the PWT.....	62
5.7.2	Adjusting the scanning head.....	66
5.7.3	Mounting the limit plates.....	69
6	Final steps.....	71
6.1	Connecting the encoder to the downstream electronics.....	71
7	Removal.....	72
7.1	Safety precautions regarding removal.....	72
7.2	Removing the scanning head.....	72
7.3	Removing the scale.....	72

1 Basic information

This chapter contains information about the product and the Mounting Instructions.

1.1 Applicability of the documentation

These Mounting Instructions are valid for the LIF 401 R, LIF 47 R, LIF 48 R, LIF 47 V, LIF 48 V, LIF 48 U.

- Prior to using the documentation, check whether the documentation and product model match
The designation of the product is printed on the ID label.

ID label

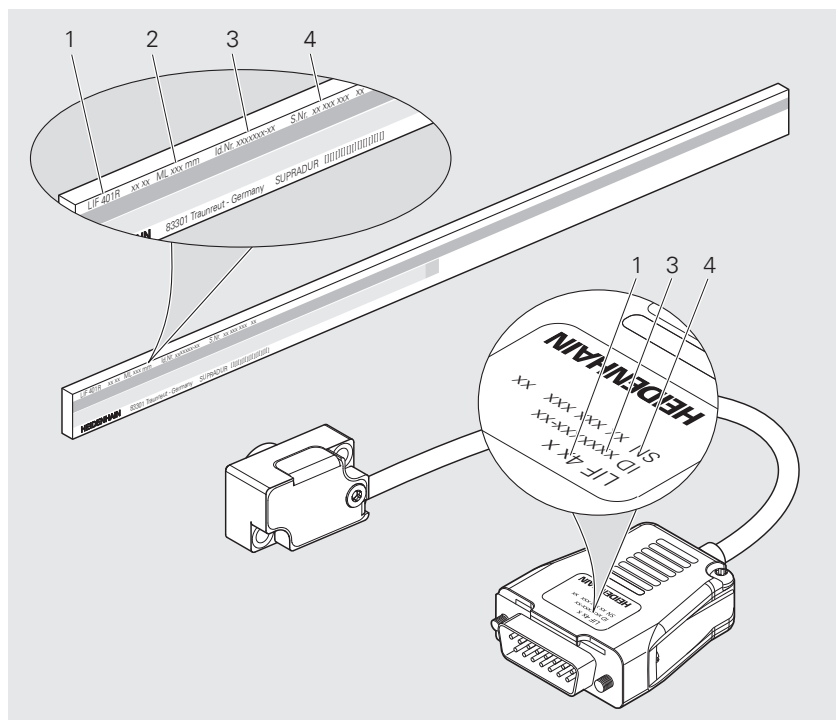

- 1 Product name
- 2 Measuring length (ML)
- 3 Product ID / Part number (ID)
- 4 Serial number (SN)

1.2 Target groups of the Mounting Instructions

The Mounting Instructions must be read and observed by every person who performs any of the following tasks:

- Design
- Mounting
- Removal

1.3 Notes on reading the documentation

WARNING

Fatal accidents, personal injury or property damage caused by non-compliance with the documentation!

Failure to comply with the documentation may result in fatal accidents, personal injury or property damage.

- ▶ Read the documentation carefully from beginning to end
- ▶ Keep the documentation for future reference

The following table lists the various parts of the documentation in their order of reading priority.

Document type	Description
Addendum	An Addendum supplements or supersedes the corresponding contents of the Operating Instructions and, if applicable, of the Mounting Instructions. If an Addendum is included in the shipment, it has the highest priority for reading. All other documentation content retains its validity.
Operating Instructions	The Operating Instructions contain all of the information and safety instructions for the proper and intended operation of the device. The Operating Instructions (English language version) are included in delivery and can also be downloaded in other languages from www.heidenhain.com/documentation . The Operating Instructions must be read prior to initial operation of the product. The Operating Instructions have the second highest priority for reading.
Mounting Instructions	The Mounting Instructions contain all the information and safety precautions needed for the proper mounting and installation of a product. The Mounting Instructions are not included in delivery and must be downloaded from www.heidenhain.com/documentation . The Mounting Instructions have the third highest priority for reading.

Would you like any changes, or have you found any errors?

We are continuously striving to improve our documentation for you. Please help us by sending your suggestions to the following e-mail address:

userdoc@heidenhain.de

1.4 Symbols and fonts used for marking text

In these instructions the following symbols and fonts are used for marking text:

Format	Meaning
▶ ...	Identifies an action and the result of this action
> ...	Example: <ul style="list-style-type: none"> ▶ Tilt the shipping brace to remove it (c) > The shipping brace has been removed now
■ ...	Identifies an item of a list
■ ...	Example: <ul style="list-style-type: none"> ■ Solid contaminants: class 3 ■ Max. pressure dew point: class 4

1.5 Notes in this documentation

Safety precautions

Precautionary statements warn of hazards in handling the product and provide information on their prevention. Precautionary statements are classified by hazard severity and divided into the following groups:

⚠ DANGER
Danger indicates hazards for persons. If you do not follow the avoidance instructions, the hazard will result in death or severe injury .

⚠ WARNING
Warning indicates hazards for persons. If you do not follow the avoidance instructions, the hazard could result in death or serious injury .

⚠ CAUTION
Caution indicates hazards for persons. If you do not follow the avoidance instructions, the hazard could result in minor or moderate injury .

NOTICE
Caution indicates danger to material or data. If you do not follow the avoidance instructions, the hazard could result in things other than personal injury, such as property damage .

Informational notes

Informational notes ensure reliable and efficient operation of the product. Informational notes are divided into the following groups:

	The information symbol indicates a tip . A tip provides important additional or supplementary information.
---	--

	The book symbol indicates a cross reference . A cross reference leads to external documentation, for example: further documentation from HEIDENHAIN or another supplier.
---	--

	The globe symbol represents a cross reference to a source on the Internet, e.g. www.heidenhain.com
---	---

1.6 Units and tolerances

Unless otherwise specified, the dimensions stated in these Mounting Instructions are given in millimeters.

Unless otherwise specified, the tolerances stated in these Mounting Instructions conform to ISO 8015 and ISO 2768 standards.

mm 
Tolerancing ISO 8015
ISO 2768:1989-mH
≤ 6 mm: ±0.2 mm

2 Safety

This chapter provides important safety information needed for the proper mounting and installation of the product.

2.1 Personnel qualification

Mounting, initial configuration and removal must be conducted by a qualified specialist under compliance with local safety regulations.

2.2 General safety precautions

WARNING

Danger of electric shock due to connection to unsuitable downstream electronics!

If you connect unsuitable downstream electronics to the product, fatal accidents or severe personal injuries can occur.

- ▶ Connect the product only to downstream electronics whose supply voltage comes from PELV systems

WARNING

Risk of injury due to plug connections under voltage!

If you disengage plug connections while the equipment is under power, this may result in fatal accidents or severe personal injury.

- ▶ Do not engage or disengage any connecting elements while the product is under power

WARNING

Risk of injury from damaged or worn components!

Safety functions can fail if damaged or worn components are installed unintentionally. Failed safety functions can result in death or serious injury.

- ▶ Inspect the component for damage
- ▶ Do not use any damaged or worn components
- ▶ In case of replacement, repair the thread
- ▶ Use new screws, spring pins and nuts
- ▶ Secure screws and nuts with suitable material-bonding anti-rotation lock

NOTICE

Property damage due to mechanical stress!

Exposing the product to mechanical stress can cause damage to the product.

- ▶ Do not drop the product or subject it to major vibration
- ▶ Do not expose the product to mechanical stress
- ▶ Do not change the physical structure of the product

NOTICE**Property damage due to electrical stress!**

Improper handling of the connecting element can cause damage to the product.

- ▶ Do not engage or disengage any connecting elements while the product is under power
- ▶ Do not touch the contacts of the plug connections

NOTICE**Electrostatic discharge (ESD)!**

This product contains electrostatically sensitive components that can be destroyed by electrostatic discharge (ESD).

- ▶ It is essential to observe the safety precautions for handling ESD-sensitive components
- ▶ Never touch connector pins without ensuring proper grounding
- ▶ Wear a grounded ESD wristband when handling the connections of the product

NOTICE**Property damage due to incorrect evacuating or ventilating!**

If the encoder is under voltage during evacuation or ventilation, this can cause damage to the encoder.

- ▶ Disconnect the encoder from the power supply before pumping air into or out of the vacuum chamber

3 Items supplied and accessories

This chapter contains information on the items supplied and the available accessories of the product.

3.1 Items supplied

3.1.1 Items supplied: Linear scale

NOTICE

Contamination due to improper opening of the packaging!

All vacuum devices are packaged in two layers of film

Film (1): vacuum

Film (2): flooded with nitrogen

- ▶ Open the second film (2) only in the clean room and while wearing gloves (nitrile)

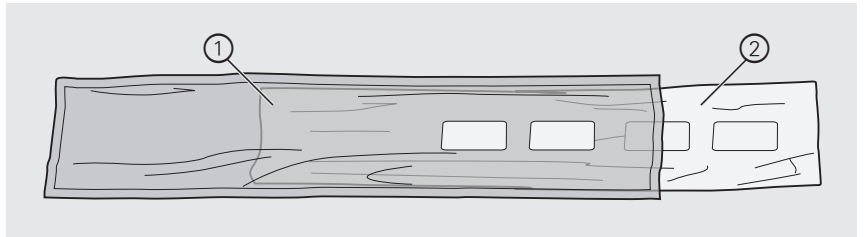

Component

Figure

Linear scale

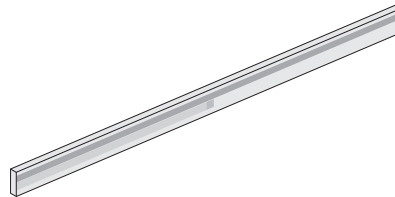

Operating Instructions

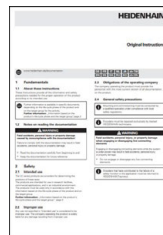

Quality Inspection Document

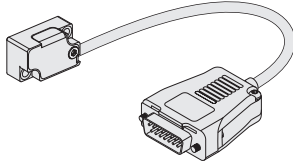
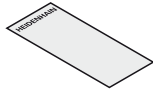
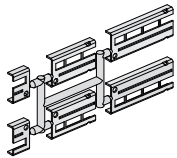
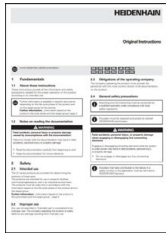
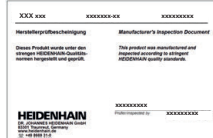

3.1.2 Items supplied: LIF 47 R, LIF 48 R scanning heads

Component	Figure
Scanning head	
Spacer shim	
Limit plates	
Operating Instructions	
Manufacturer's Inspection Document	

3.1.3 Items supplied: LIF 47 V, LIF 48 V, LIF 48 U scanning heads

NOTICE

Contamination due to improper opening of the packaging!

All vacuum devices are packaged in two layers of film

Film (1): vacuum

Film (2): flooded with nitrogen

- ▶ Open the second film (2) only in the clean room and while wearing gloves (nitrile)

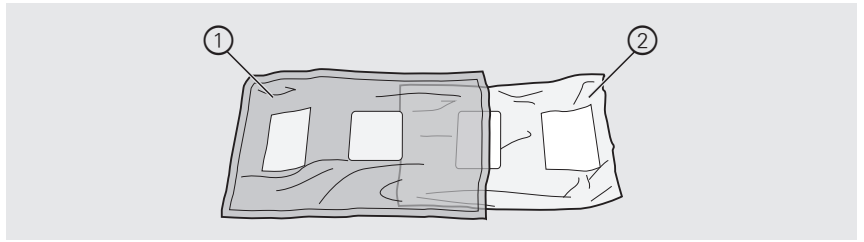

Component	Figure
Scanning head	
Spacer shim	
Limit plates	
Operating Instructions	
Manufacturer's Inspection Document	

3.2 Mounting accessories

The following accessories can be ordered separately from HEIDENHAIN.



For more information on the listed products, please refer to the applicable Mounting Instructions and the **Exposed Linear Encoders** brochure.



- ▶ www.heidenhain.com/documentation
- ▶ Enter the document ID **208960**

3.2.1 Accessories for mounting the linear scale

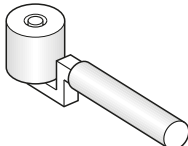
Accessories for mounting with adhesive film

Designation	ID	Figure
Roller	276885-01	

Accessories for mounting with fixing clamps

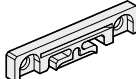
Designation	ID	Figure
Spacer shim	1176441-xx	
Fixing clamps	1176458-xx	
Fixed-point elements	1176475-xx	

3.2.2 Accessories for mounting the LIF 47 R, LIF 48 R scanning heads

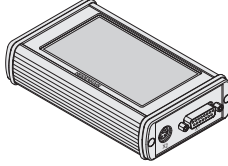
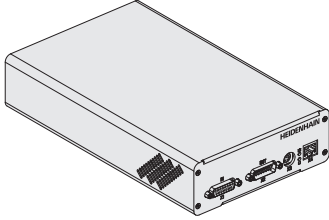

Designation	ID	Figure
PWT 101 testing device	1261013-01	
or		
PWM 21 inspection device	1200635-51	

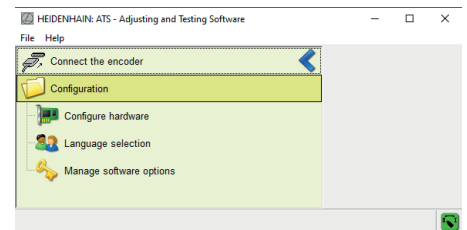
Adjusting and Testing Software (ATS)

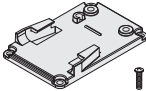
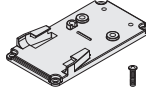

The ATS is available for download free of charge.

- ▶ www.heidenhain.com/service/downloads/software/
- ▶ Open the **Categories** selection menu
- ▶ Select the **Inspection and testing devices** category

Mounting adapter	1234395-01	
Mounting adapter Compatible with predecessor	1234395-02	
Adapter for adjusting with PWM	317505-08	

3.2.3 Accessories for mounting the LIF 47 V, LIF 48 V, LIF 48 U scanning heads

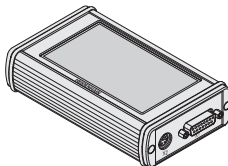
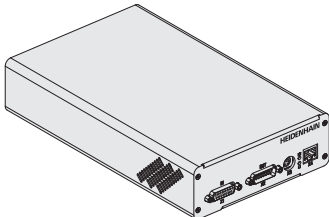
Designation	ID	Figure
PWT 101 testing device	1261013-01	
or		
PWM 21 inspection device	1200635-51	

Adjusting and Testing Software (ATS)

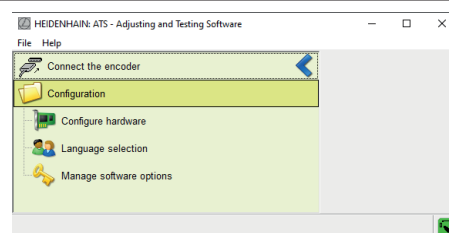

The ATS is available for download free of charge.

- ▶ www.heidenhain.com/service/downloads/software/
- ▶ Open the **Categories** selection menu
- ▶ Select the **Inspection and testing devices** category

3.2.4 Accessories for fixed-point bonding

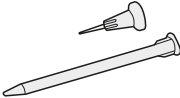
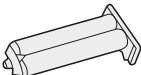
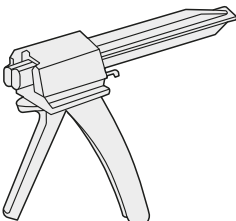
Designation	ID	Figure
Dispensing nozzles and mixing tubes	1176444-01	
Adhesive 3M DP 460 EG	1180444-01	
Double-cartridge gun	1180450-01	

4 Mounting

This chapter describes the mounting requirements, different mounting variants, and all other tasks necessary when mounting.

4.1 Requirements and notes

NOTICE

Property damage due to inappropriate tools!

Using inappropriate tools for mounting or removal of the encoder may cause damage to the encoder.

- ▶ Do not use hammers
- ▶ Do not use pointed or sharp-edged tools

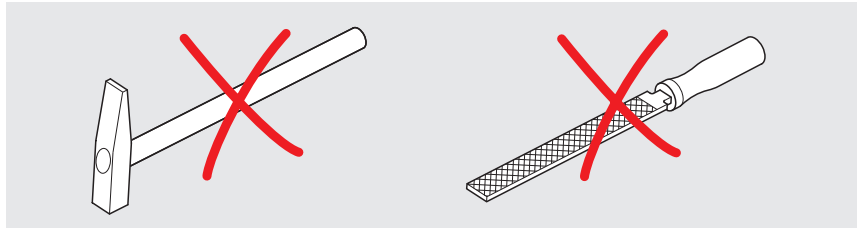

Choose a mounting attitude such that the traverse range is within the measuring length (ML) of the encoder.

(S) = Beginning of measuring length (ML)

Protect the graduation from direct contamination.

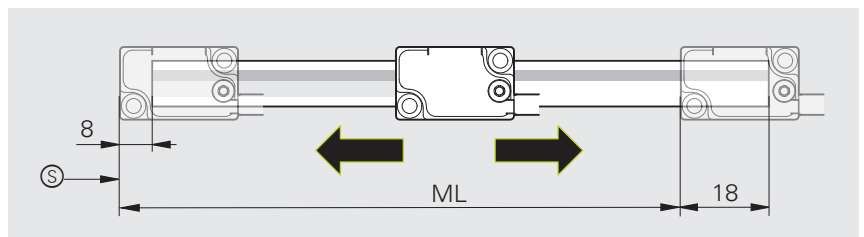

In order to ensure correct operation of the encoder, the scale must be positioned correctly relative to the scanning head.

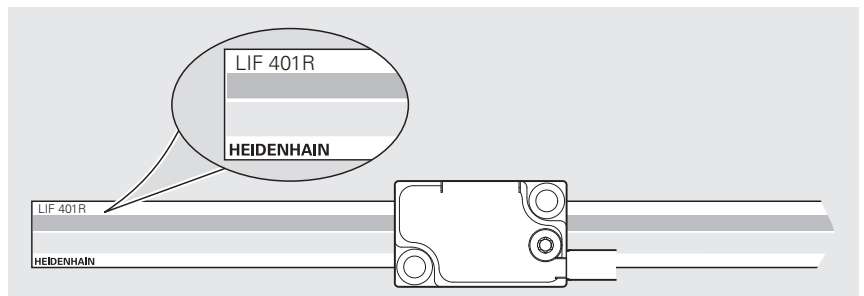

In order to avoid signal interferences, observe the minimum clearance from sources of interference (e.g., power lines).



For more information on sources of interference, refer to the **Interfaces of HEIDENHAIN Encoders** brochure.

- ▶ www.heidenhain.com/documentation
- ▶ Enter the document ID **1078628**



For more information on mounting, refer to the **Mating Dimensions** document.

- ▶ www.heidenhain.com/documentation
- ▶ Enter the product ID
- ▶ Open the product
- ▶ Open **Mating Dimensions**

4.2 Mounting the linear scale

4.2.1 Choosing the mounting variant

Mounting variants for the linear scale

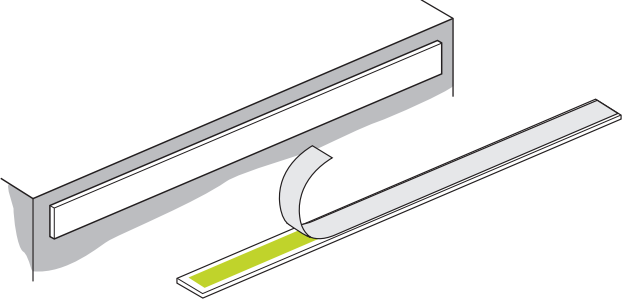
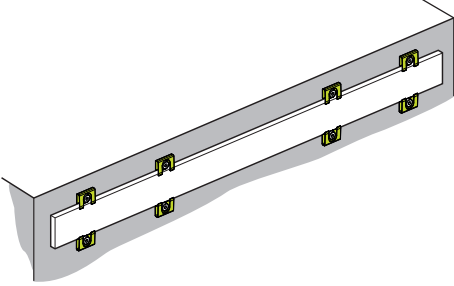
Mounting with adhesive film	Mounting with fixing clamps
 <p data-bbox="113 902 213 936">Page 18</p>	 <p data-bbox="799 902 906 936">Page 22</p>

4.2.2 Variant: Mounting with adhesive film

This chapter describes the mounting process of the scale with adhesive film. An overview of the mounting variants is provided on Page 17.

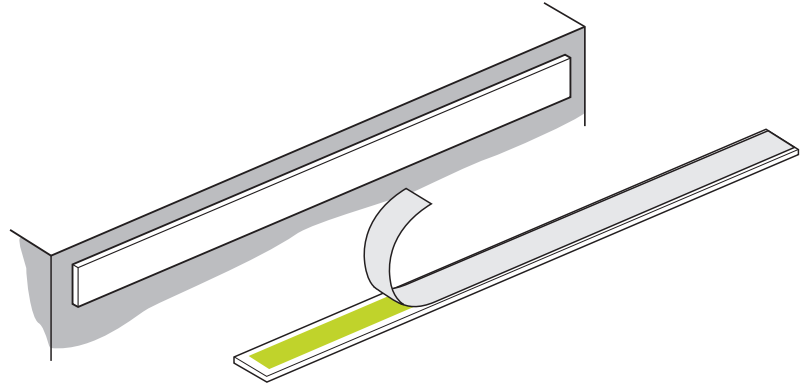

Notes on mounting with adhesive film

Note that the mounting surface, as well as the surface of the scale, must be clean and free of paint, dust or grease.

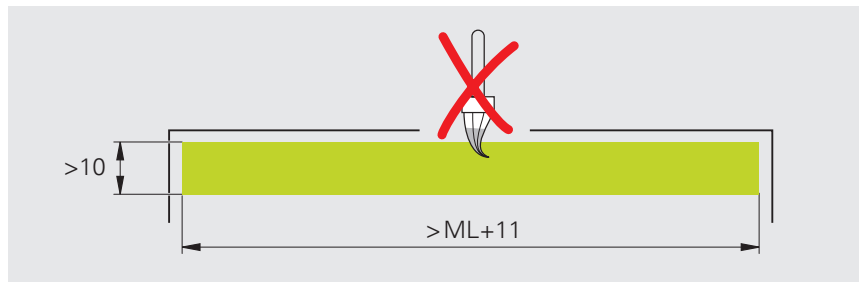

i You can mount the linear scale by means of stop pins or an aligning rail.

The mounting tolerances refer to the machine guideway (F).

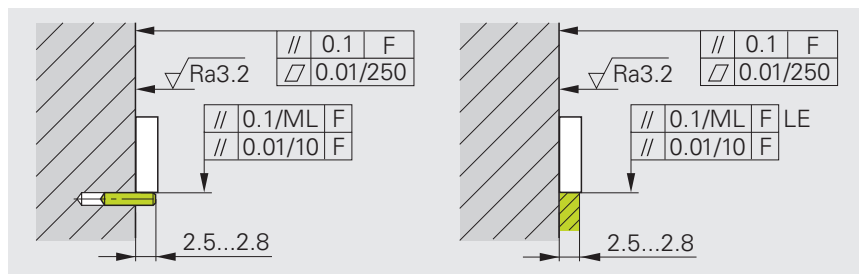

Number of stop pins to be used

Recommended diameter of the stop pins: 3 mm.

Use three stop pins to stabilize the scale sufficiently.

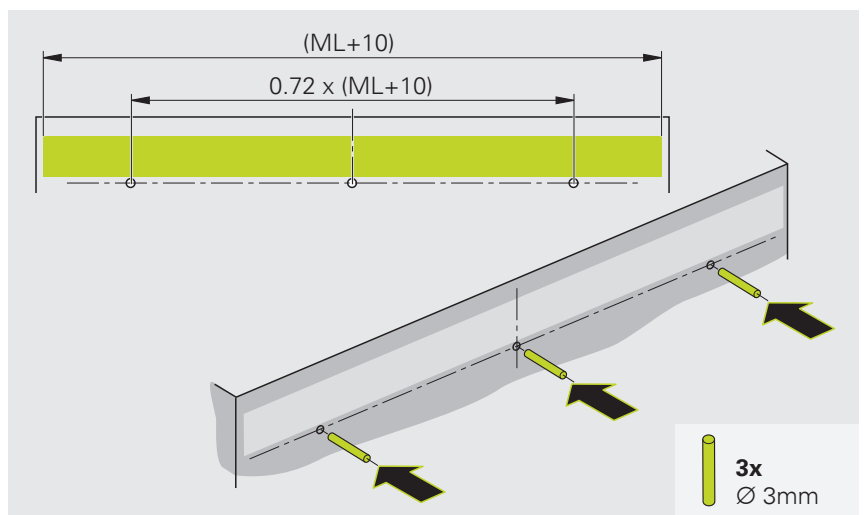

Materials and tools

For this task, the following materials and tools are needed:

Included in delivery

To be provided separately

- Stop pins
- Roller
- Dispensing nozzle and mixing tubes
- Adhesive 3M DP 460 EG
- Double-cartridge gun

Gluing the linear scale

Attach the scale with adhesive mounting film only at a temperature of $> 15\text{ }^{\circ}\text{C}$.

Pay attention to the expiration date on the package.

- ▶ Insert the stop pins
- ▶ Remove the protective foil from the adhesive film

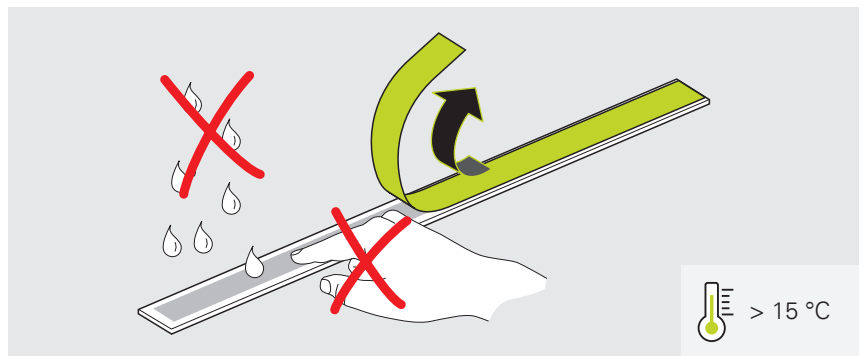

- ▶ Carefully place the scale onto the stop pins
- ▶ Starting from the center, evenly press the scale onto the mounting surface using the roller
- ▶ Remove the stop pins

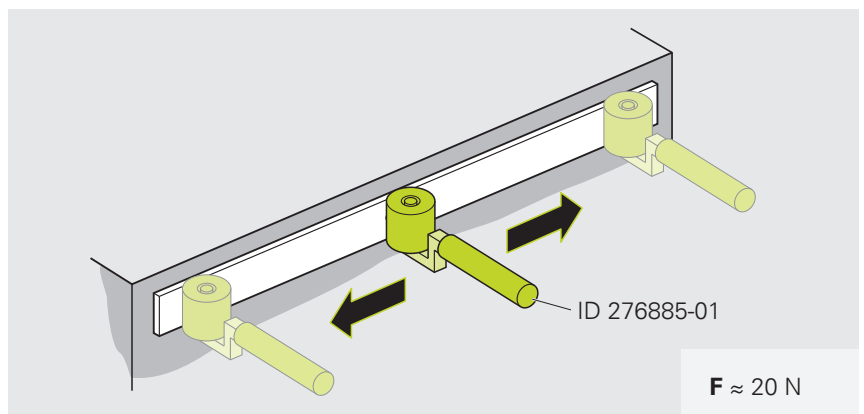

Scales with a measuring length (ML) of < 170 require fixed-point bonding.

- ▶ Secure the scale with adhesive in the center (dispensing length: 10 to 20 mm)

Further information: "Bonding the fixed point", Page 21

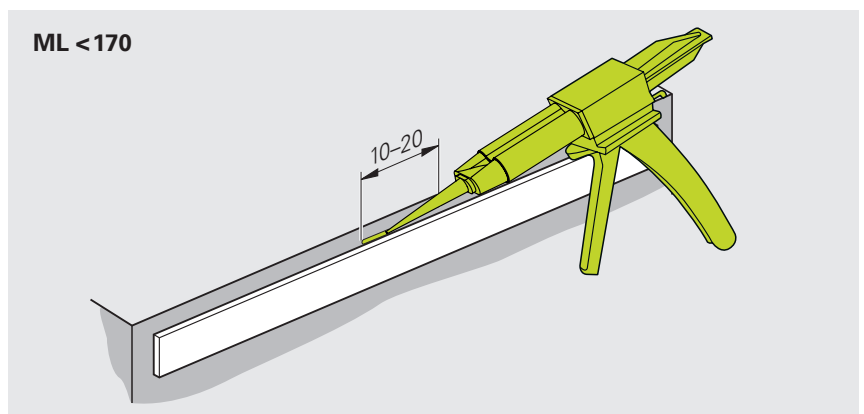

- ▶ Do not perform further work on the linear scale until the maximum adhesive force has been reached



The maximum adhesive force of the mounting film is reached at room temperature after approx. 70 hours.

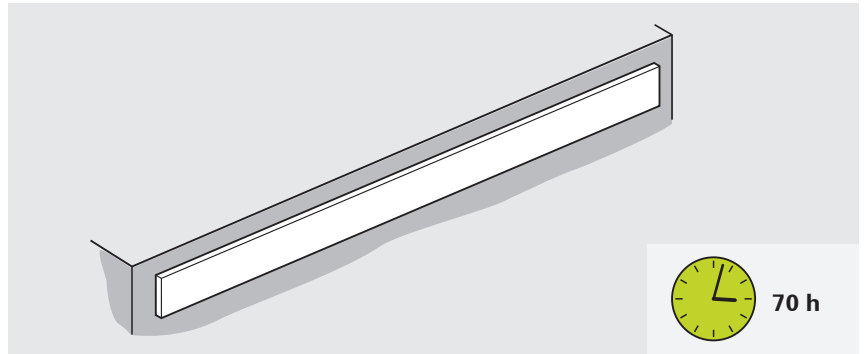

Bonding the fixed point

Due to potential thermal effects, HEIDENHAIN recommends fixed-point bonding at the center.

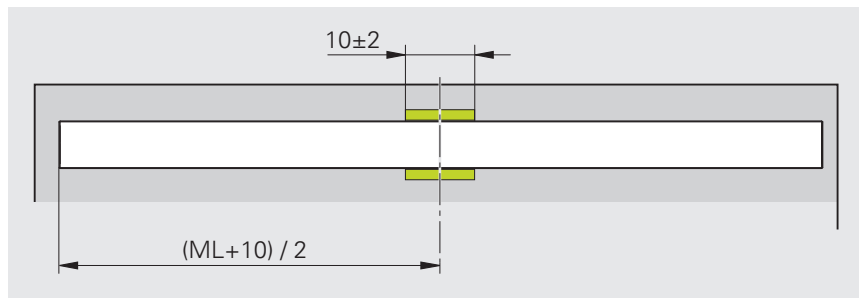

i Pay attention to the work instructions in the applicable documentation.

i Do not add more adhesive afterwards.

- ▶ Apply a bead of adhesive with a double cartridge gun and a dispensing nozzle
- ▶ Allow the adhesive to harden as appropriate for the intended operating temperature

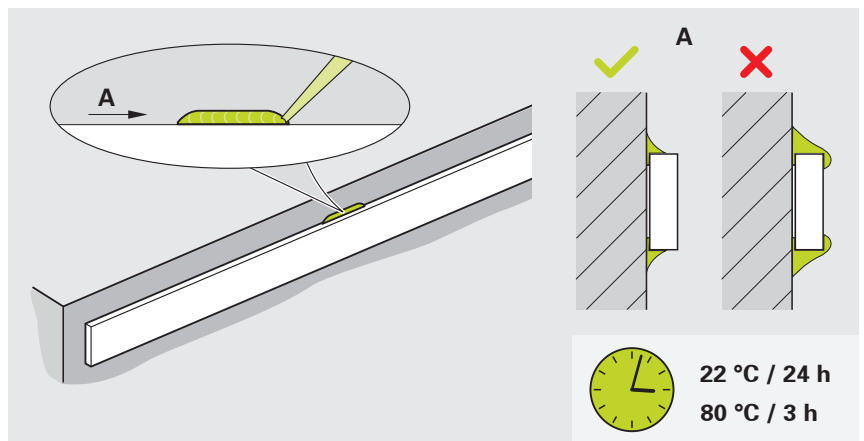

To ensure high fixed-point rigidity, pay attention to the specifications for curing temperature and curing time.

Operating temperature	Curing temperature	Curing time
-10 °C to +30 °C	22 °C	24 hours
-10 °C to +70 °C	80 °C	3 hours

Next step: "Mounting the scanning head", Page 27

4.2.3 Variant: Mounting with fixing clamps

This chapter describes the mounting process of the scale using fixing clamps.

An overview of the mounting variants is provided on Page 17.

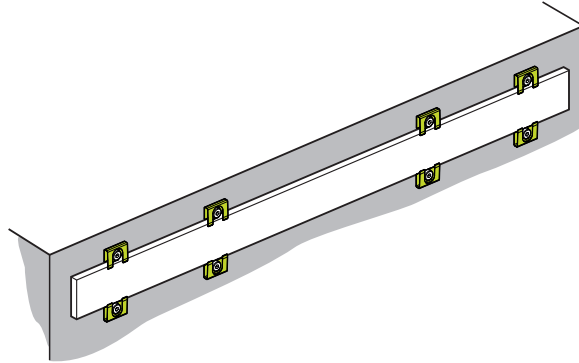

Notes on mounting with fixing clamps

Note that the mounting surface, as well as the surface of the scale, must be clean and free of paint, dust or grease.

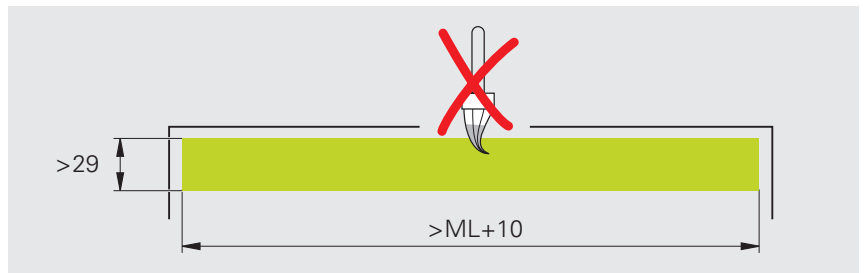

The mounting tolerances refer to the machine guideway (**F**).

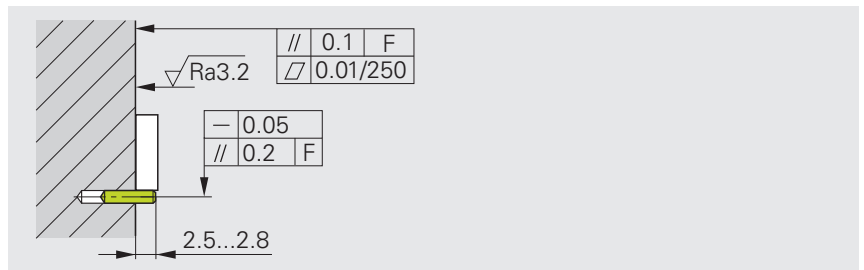

Number of stop pins to be used

Recommended diameter of the stop pins: 3 mm.

Use three stop pins to stabilize the scale sufficiently.

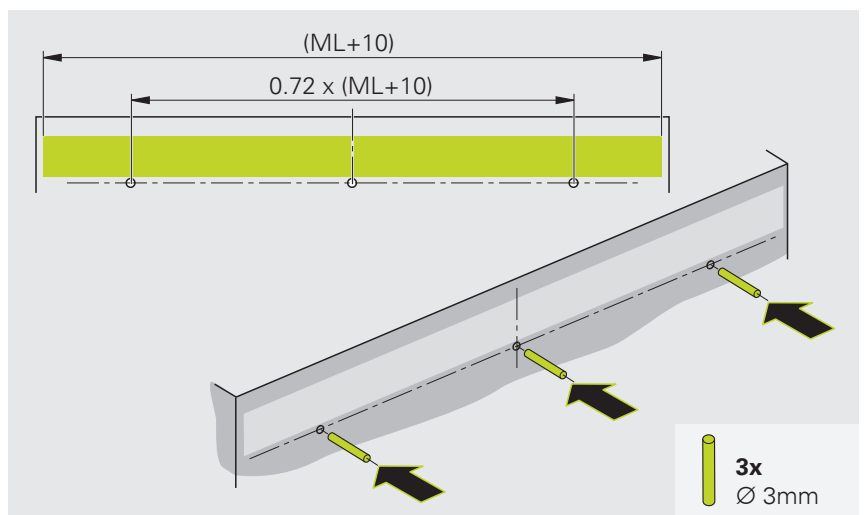

Materials and tools

For this task, the following materials and tools are needed:

Included in delivery

To be provided separately

- Fixing clamps
- Spacer shims
- Stop pins
- Fixed-point elements
- Screws (DIN 7984 – M3x6)
- Washers (ISO 7092–3)
- Torque wrench (hexagon socket for 2.5 mm)
- Dispensing nozzle and mixing tubes
- Adhesive 3M DP 460 EG
- Double-cartridge gun

Mounting the fixing clamps

- ▶ Insert the stop pins
- ▶ Remove the protective film of the scale
- ▶ Carefully place the scale onto the stop pins

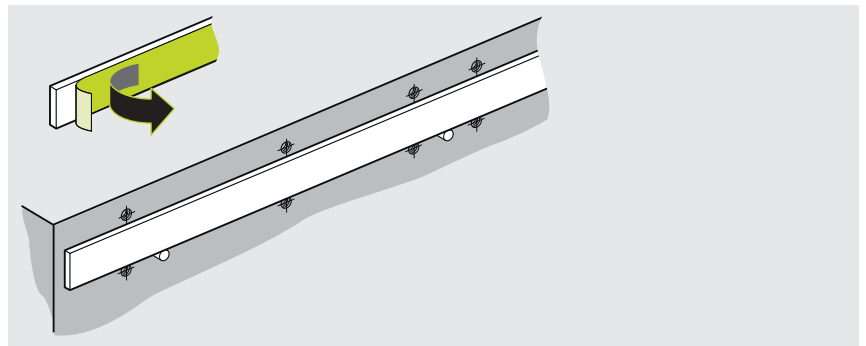

- ▶ Press all fixing clamps lightly in the direction of the scale and fasten them with screws and washers. Tighten the screws only lightly

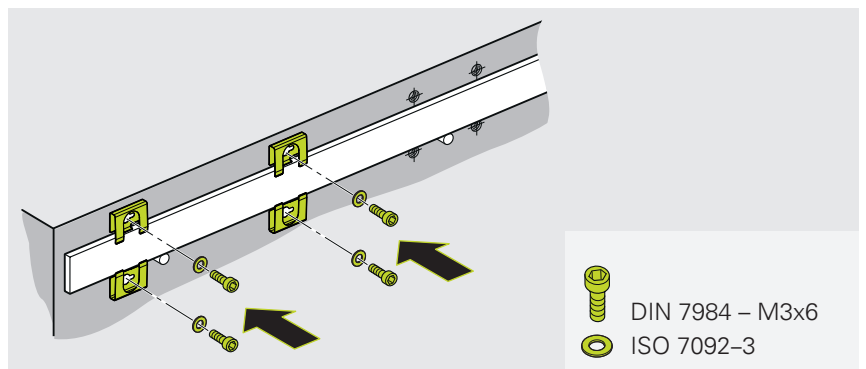

Perform the following steps only with those fixing clamps that are nearest to, but across from, a stop pin:

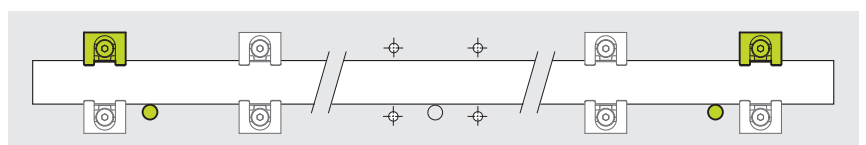

- ▶ Place the spacer shim between the fixing clamp and scale
- ▶ Align the fixing clamp at a right angle to the scale
- ▶ Tighten the screw using the prescribed torque



Do not remove the spacer shims.

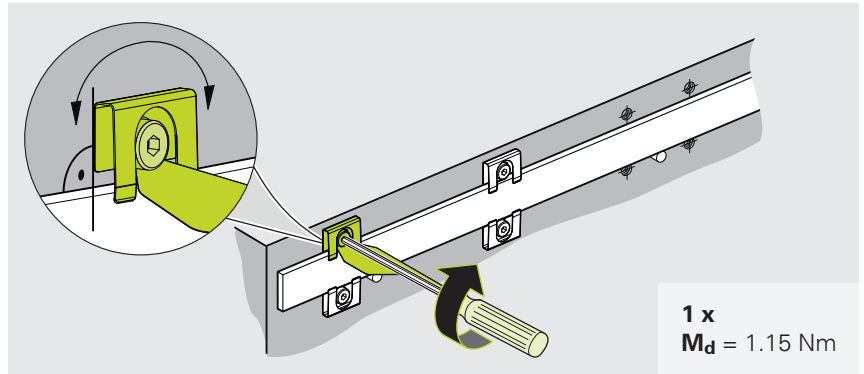

Mounting the fixed-point element

Pay attention to the mounting dimensions. Deviations from the mounting dimensions lead to imprecise measurement results during operation.

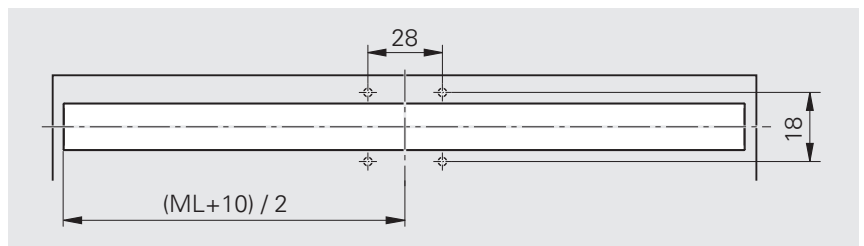

- ▶ Align the fixed-point element in parallel
- ▶ Lightly press the upper fixed-point element against the scale and fasten it with screws using the prescribed torque

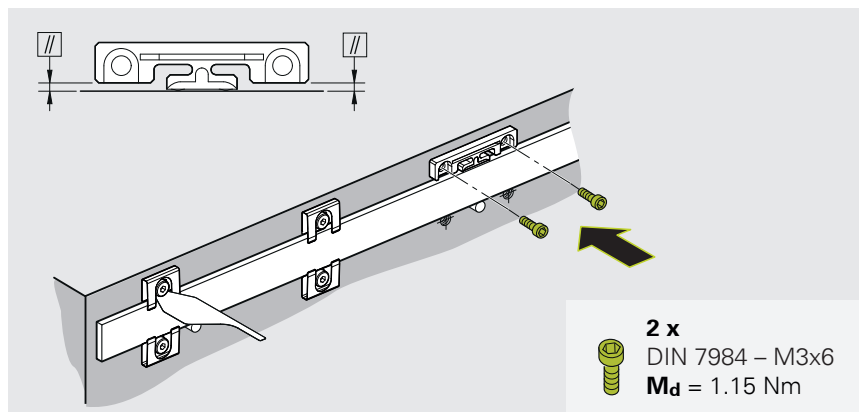

- ▶ Remove the stop pin

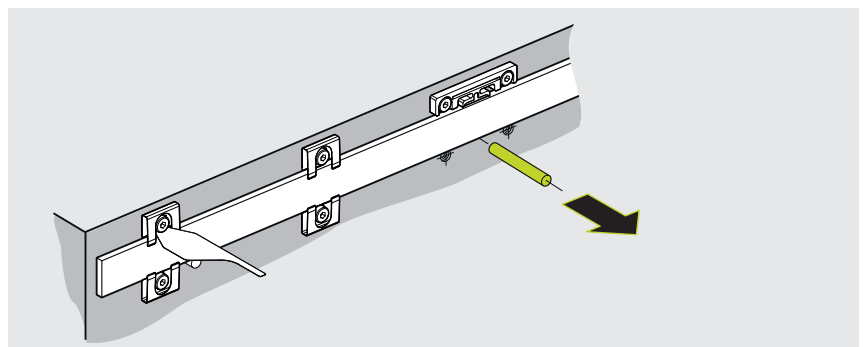

- ▶ Align the fixed-point element in parallel
- ▶ Lightly press the lower fixed-point element against the scale and fasten it with screws using the prescribed torque

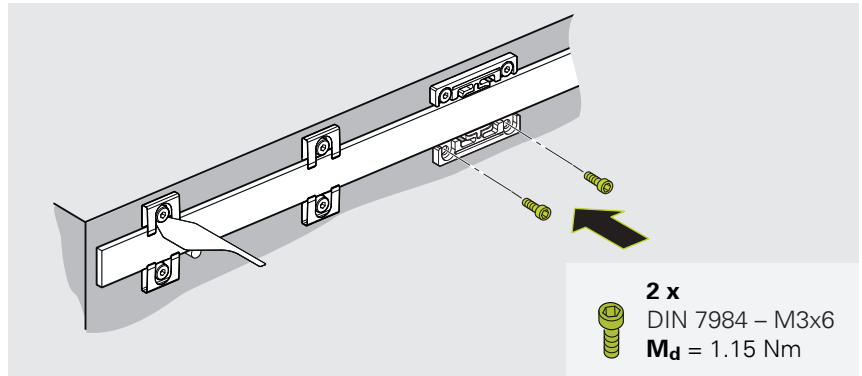

Tightening the fixing clamps

- i**
- The figure shows an example. The number and position of the fixing clamps and stop pins depends on the length of the linear scale.
 - Always tighten the fixing clamps in pairs.

- ▶ Place the spacer shims between each pair of fixing clamps and the scale
- ▶ Tighten the screws using the prescribed torque
- ▶ Remove the spacer shims and use them for the next pair of fixing clamps
- ▶ Tighten the screws in the sequence shown

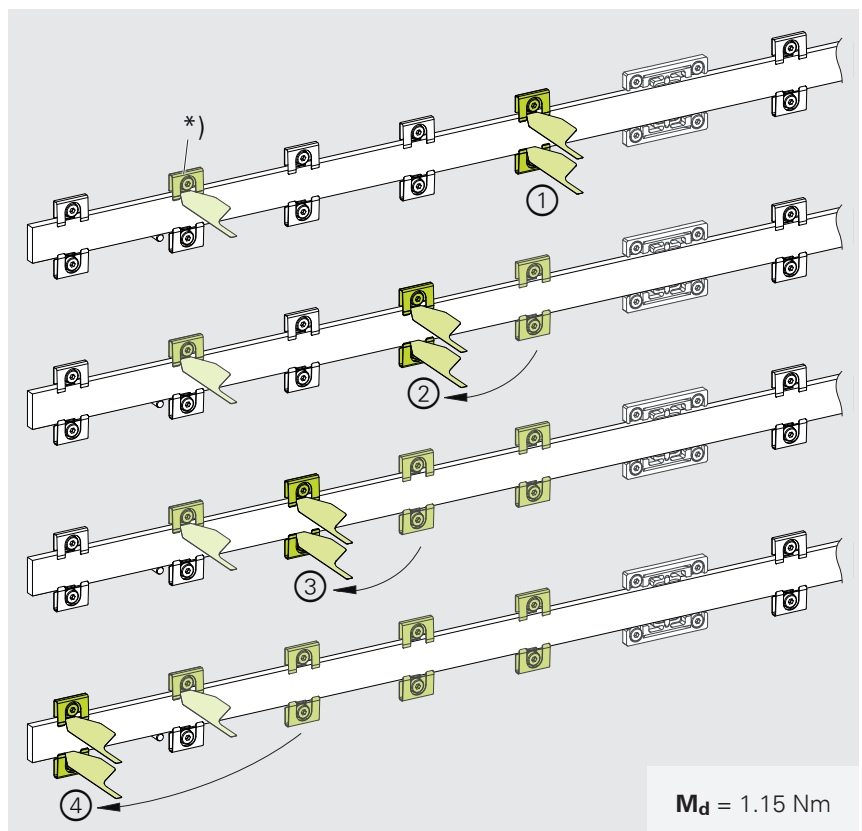

*) Do not remove the spacer shims from the first tightened fixing clamps until all fixing clamps have been tightened.

- ▶ Remove the stop pin
- ▶ Finally, tighten the fixing clamp opposite the first fixing clamp that was tightened
- ▶ Tighten the screws on the other side of the fixed-point element according to the same pattern

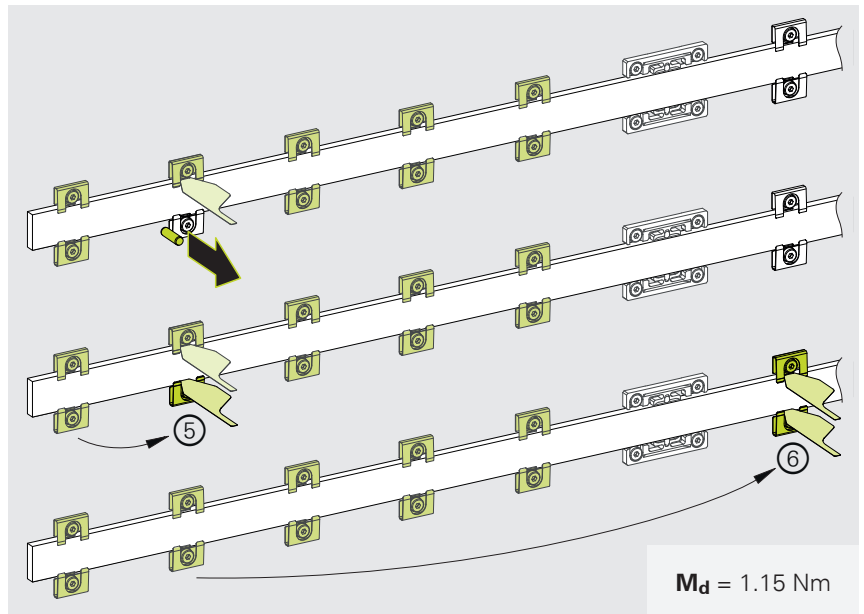

Bonding the fixed-point elements

i Pay attention to the work instructions in the applicable documentation.

i Do not add more adhesive afterwards.

- ▶ Apply a bead of adhesive with a double cartridge gun and a dispensing nozzle
- ▶ Allow the adhesive to harden as appropriate for the intended operating temperature

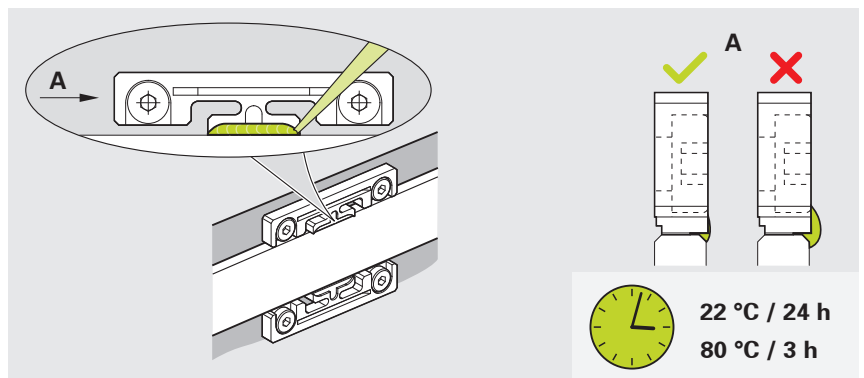

To ensure high fixed-point rigidity, pay attention to the specifications for curing temperature and curing time.

Operating temperature	Curing temperature	Curing time
-10 °C to +30 °C	22 °C	24 hours
-10 °C to +70 °C	80 °C	3 hours

Next step: "Mounting the scanning head", Page 27

4.3 Mounting the scanning head

4.3.1 Selecting the product variant

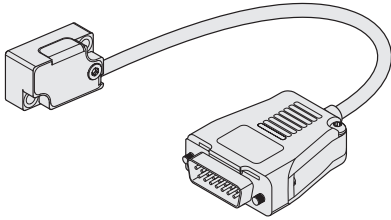
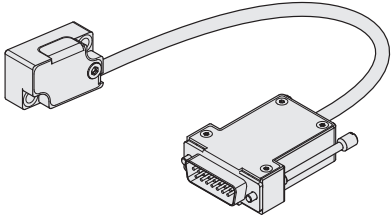
Scanning head variants	
LIF 47 R, LIF 48 R	LIF 47 V, LIF 48 V, LIF 48 U
	
Page 28	Page 30

4.3.2 Mounting the LIF 47 R, LIF 48 R scanning heads

The mounting procedure described in this chapter refers to mounting of the LIF 47 R and LIF 48 R scanning heads.

For an overview of the product variants, refer to Page 27.

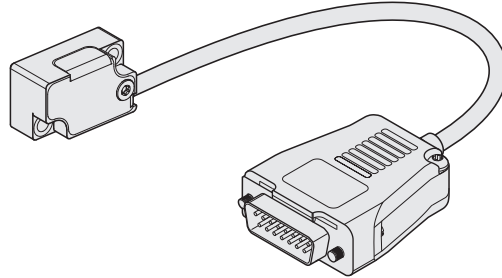

Notes on mounting the scanning head



The tightening torques of the mounting screws are only valid for mounting on steel.

CAUTION

Irritation from isopropyl alcohol

Contact with isopropyl alcohol or inhaling isopropyl alcohol fumes can cause irritation affecting the skin, eyes, or respiratory system.

- ▶ Wear protective gloves and safety goggles
- ▶ Wear respiratory protection
- ▶ Keep the workplace well ventilated
- ▶ Comply with the manufacturer's safety data sheets

NOTICE

Property damage due to unsuitable cleaning agents!

The use of inappropriate cleaning agents causes damage to the encoder.

- ▶ Use only isopropyl alcohol to clean the encoder
- ▶ Clean the encoder with a lint-free cloth

- ▶ If necessary, clean the graduation and the scanning head with a lint-free cloth and isopropyl alcohol

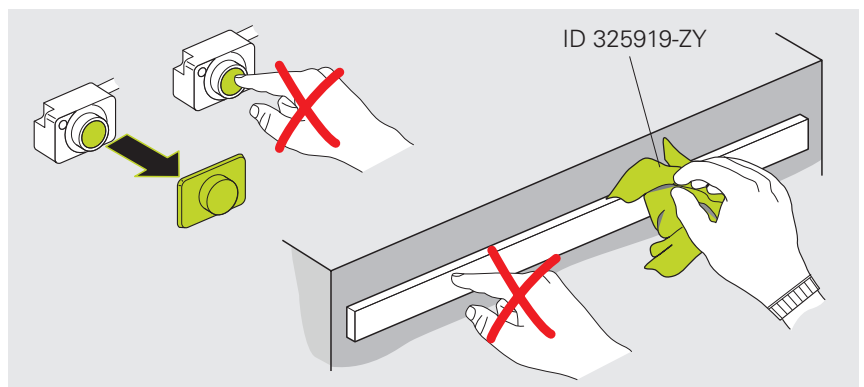

Pay attention to the mounting dimensions. Deviations from the mounting dimensions lead to imprecise measurement results during operation.

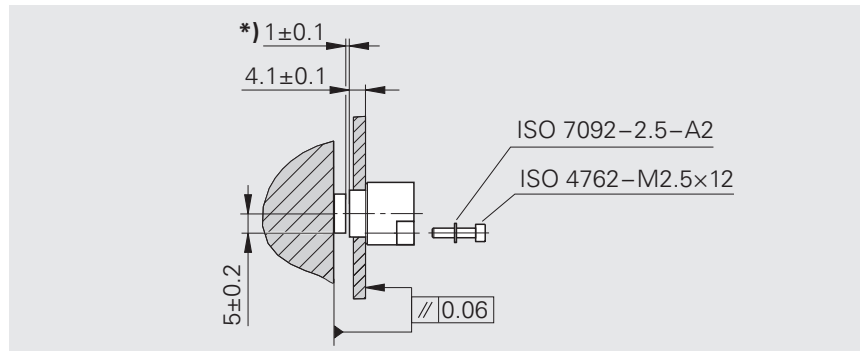

*) Mounting clearance

Materials and tools

For this task, the following materials and tools are needed:

Included in delivery

- Spacer shim

To be provided separately

- Two screws (ISO 4762-M2.5x12)
- Two washers (ISO 7092-2.5-A2)
- Torque wrench (hexagon socket for 2 mm)

Mounting the scanning head

- ▶ If necessary, remove the protective cap from the scanning head
- ▶ If necessary, remove the protective film from the scale

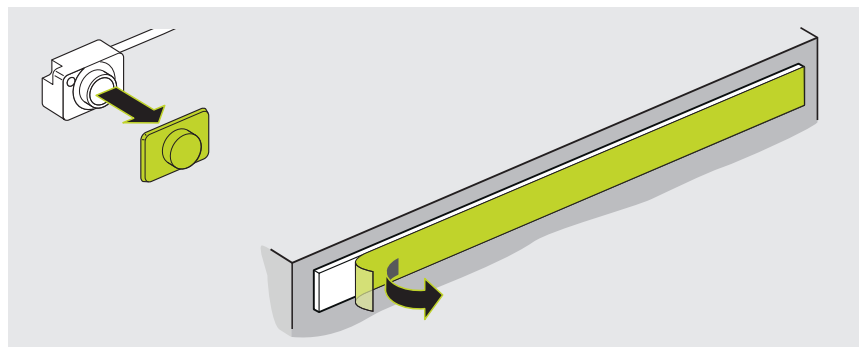

- ▶ Use the spacer shim to set the mounting clearance
- ▶ Lightly tighten the screws on the scanning head
- ▶ Remove the spacer shim

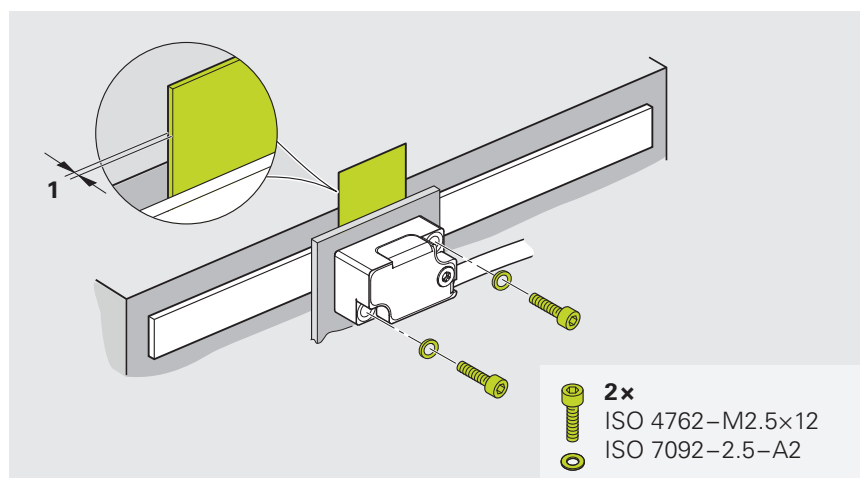

Next step: "Adjustment and diagnosis", Page 33

4.3.3 Mounting the LIF 47 V, LIF 48 V, LIF 48 U scanning heads

The mounting procedure described in this chapter refers to mounting of the LIF 47 V, LIF 48 V, and LIF 48 U scanning heads.

For an overview of the product variants, refer to Page 27.

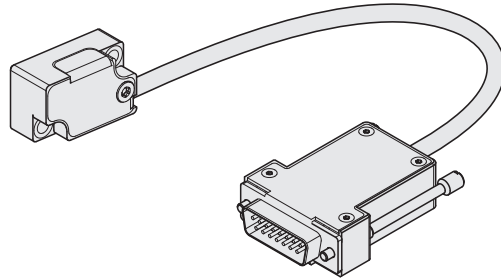

Notes on mounting the scanning head

i The tightening torques of the mounting screws are only valid for mounting on steel.

NOTICE

Property damage due to improper strain on the vacuum cable!

Improper strain on the vacuum cable causes damage to the cable (e.g., breakage of wires).

- ▶ Do not stretch or twist the vacuum cable

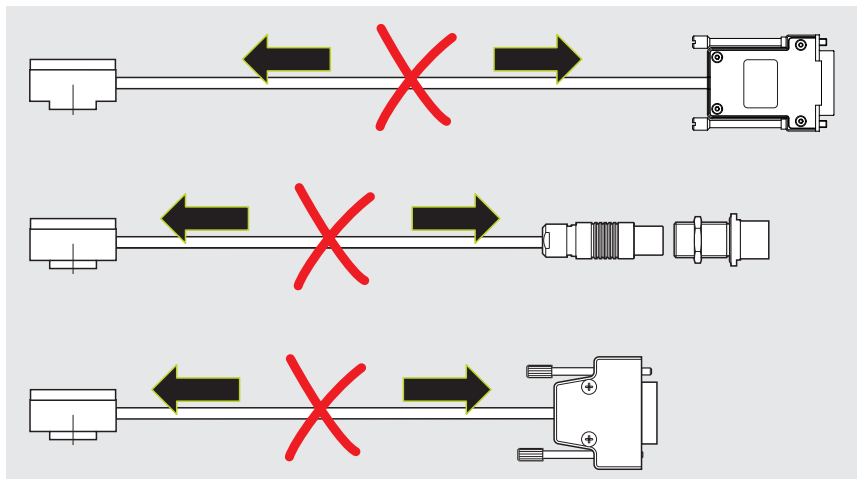

Pay attention to the application notes

- (1) Vacuum
- (2) Ultrahigh vacuum

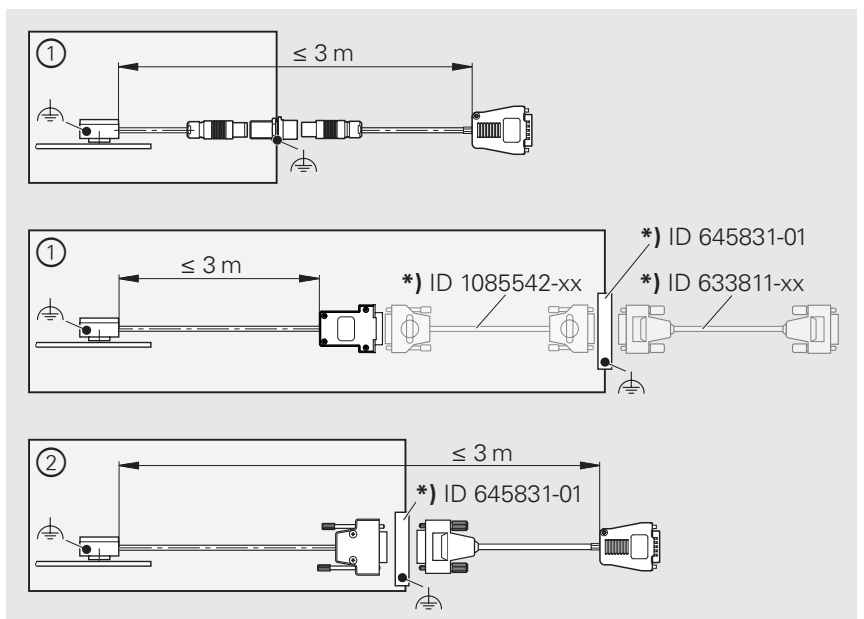

*) To be ordered separately

CAUTION

Irritation from isopropyl alcohol

Contact with isopropyl alcohol or inhaling isopropyl alcohol fumes can cause irritation affecting the skin, eyes, or respiratory system.

- ▶ Wear protective gloves and safety goggles
- ▶ Wear respiratory protection
- ▶ Keep the workplace well ventilated
- ▶ Comply with the manufacturer's safety data sheets

NOTICE

Property damage due to unsuitable cleaning agents!

The use of inappropriate cleaning agents causes damage to the encoder.

- ▶ Use only isopropyl alcohol to clean the encoder
- ▶ Clean the encoder with a lint-free cloth

- ▶ If necessary, clean the graduation and the scanning head with a lint-free cloth and isopropyl alcohol

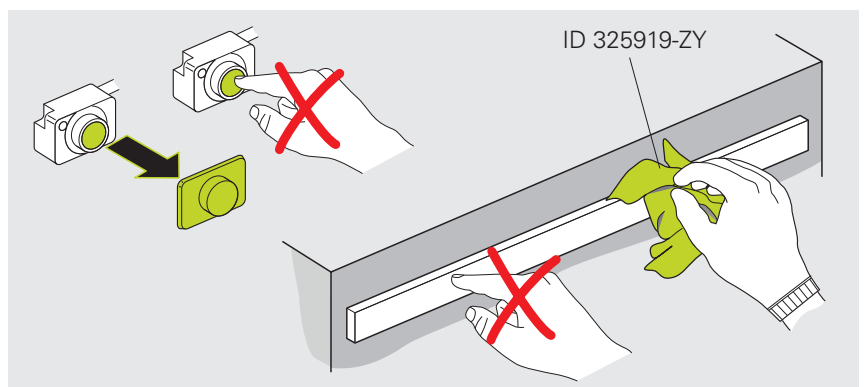

Pay attention to the mounting dimensions. Deviations from the mounting dimensions lead to imprecise measurement results during operation.

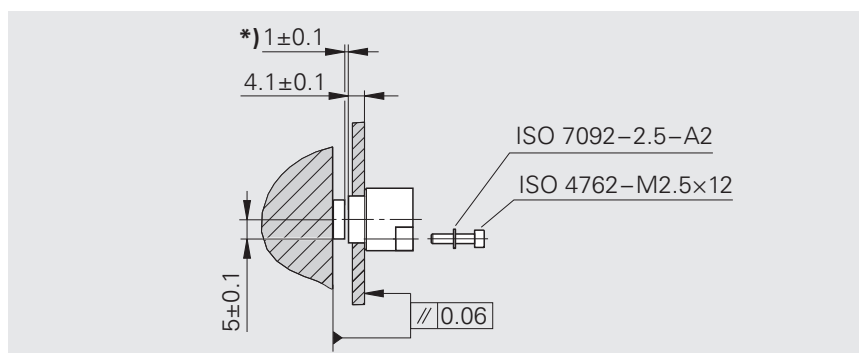

*) Mounting clearance

Materials and tools

For this task, the following materials and tools are needed:

Included in delivery

- Spacer shim

To be provided separately

- Two screws (ISO 4762-M2.5x12)
- Two washers (ISO 7092-2.5-A2)
- Torque wrench (hexagon socket for 2 mm)
- Resistance measuring device

Mounting the scanning head

- ▶ If necessary, remove the protective cap from the scanning head

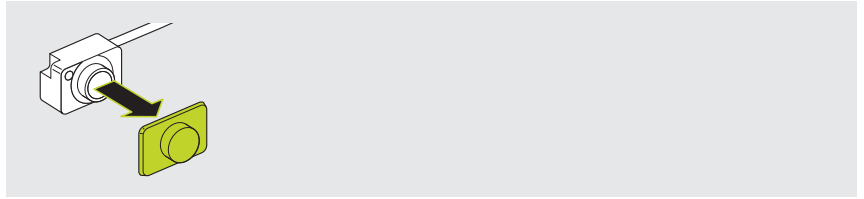

i Do not insert the spacer shim near the fixing clamps.

- ▶ Use the spacer shim to set the mounting clearance
- ▶ Lightly tighten the screws on the scanning head
- ▶ Remove the spacer shim

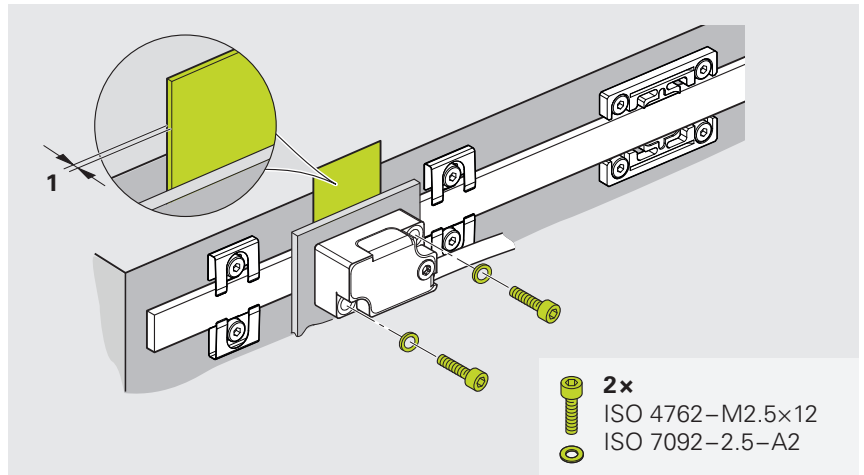

- ▶ Check the electrical resistance between the vacuum chamber and the attachment of the scanning head

i The electrical resistance between the vacuum chamber and the scanning head attachment must be $< 1 \Omega$.

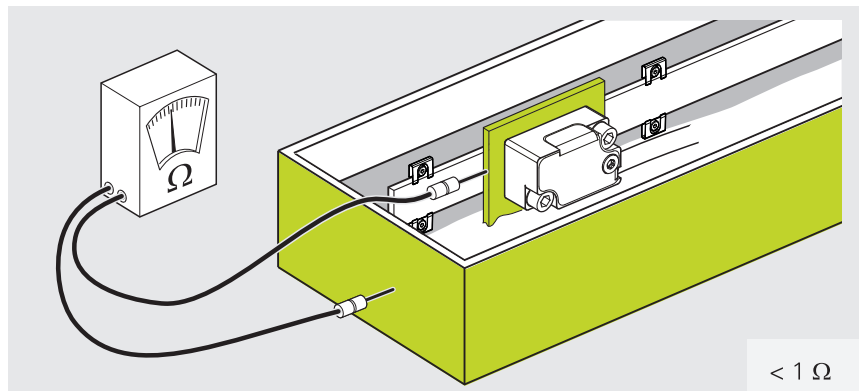

Next step: "Adjustment and diagnosis", Page 33

5 Adjustment and diagnosis

This chapter describes the continuity test, as well as the adjustment and diagnosis with a testing device (e.g., PWT 101).

5.1 Requirements and notes

A testing device (e.g., PWT 101) is required for adjustment and diagnosis. As an alternative, an inspection device (e.g., PWM 21) can be used.



For more information, refer to the **PWT 100/PWT 101 Operating Instructions**.

- ▶ www.heidenhain.com/documentation
- ▶ Enter the document ID **1162581**



For more information, see the **Exposed Linear Encoders** brochure.

- ▶ www.heidenhain.com/documentation
- ▶ Enter the document ID **208960**

5.2 Continuity check

5.2.1 Materials and tools

For this mounting step, the following materials and tools are needed:

Included in delivery

To be provided separately

- Resistance measuring device

5.2.2 Measuring the electrical resistance

- ▶ Check the electrical resistance between the connector housing and the machine



The electrical resistance between the connector housing and the machine must be $< 1 \Omega$.

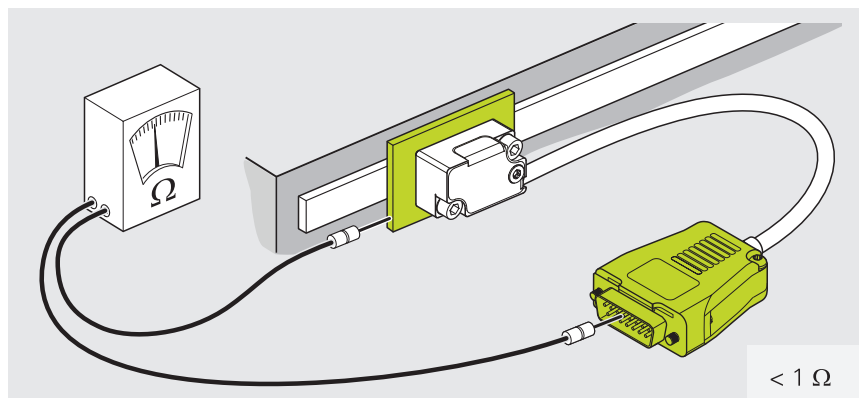

5.3 Selecting the scanning head

Scanning head variants			
LIF 47 R	LIF 48 R	LIF 47 V	LIF 48 V, LIF 48 U
Scanning head with TTL interface	Scanning head with 1 V _{PP} interface	Scanning head with TTL interface	Scanning head with 1 V _{PP} interface
Page 35	Page 44	Page 54	Page 62

5.4 Adjustment and diagnosis of LIF 47 R

5.4.1 Connecting the encoder to the PWT

Connecting the encoder

NOTICE

Property damage due to electrical stress!

Improper handling of the connecting element can cause damage to the product.

- ▶ Do not engage or disengage any connecting elements while the product is under power

- ▶ Connect the encoder to the PWT 101
- ▶ Connect the PWT 101 to the power supply

Selecting the connection

Connection options

Connecting the encoder automatically	Connecting the encoder manually
Recommended option with automatic determination of the measuring parameters. Page 36	Alternative option if the encoder cannot be connected automatically. Page 37

Connecting the encoder automatically

- ▶ Tap **Automatic Diagnosis** in the main menu
- > The **Automatic Diagnosis** is performed.
- > The **Level display** screen is opened.

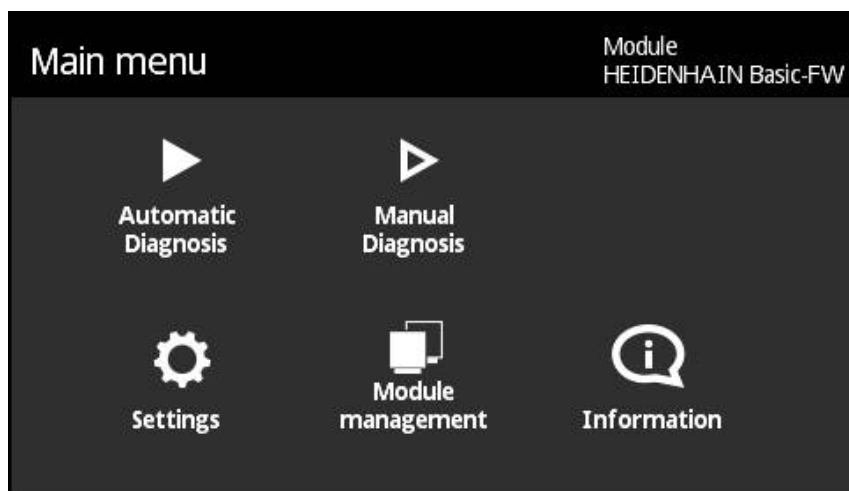

Main menu



If you cannot connect the encoder automatically, proceed as described in the **Connecting the encoder manually** chapter.

Next step: "Adjusting the scanning head", Page 39

Connecting the encoder manually

- ▶ Tap **Manual diagnostics** in the main menu
- > The **Supply voltage of encoder** screen is opened.

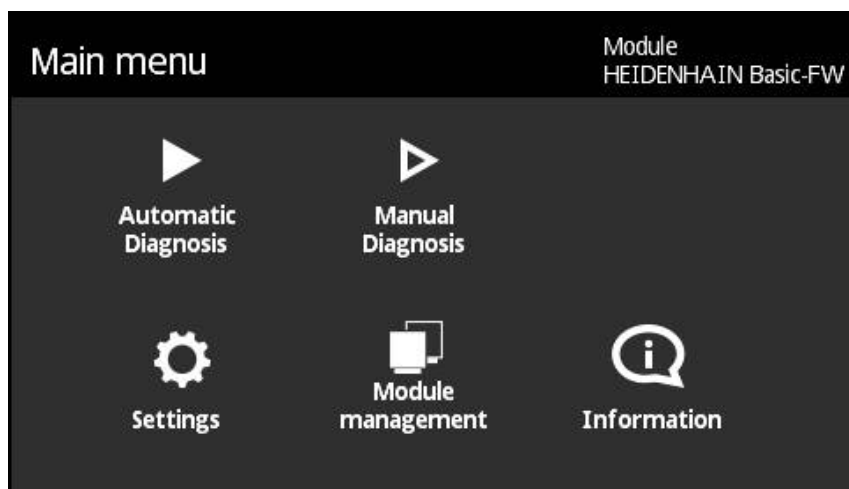

Main menu

- ▶ Select the supply voltage
- ▶ Activate the **Adjust supply voltage** checkbox, if required
- ▶ Swipe right to left
- > The **Encoder interface** screen is opened.

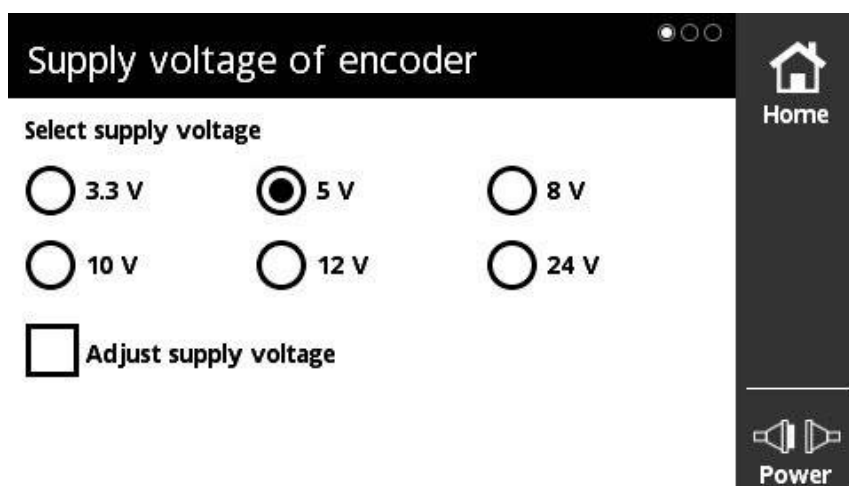

The **Supply voltage of encoder** screen

- ▶ Select the encoder interface
- ▶ Swipe right to left
- > The **Manual diagnostics** screen is opened.

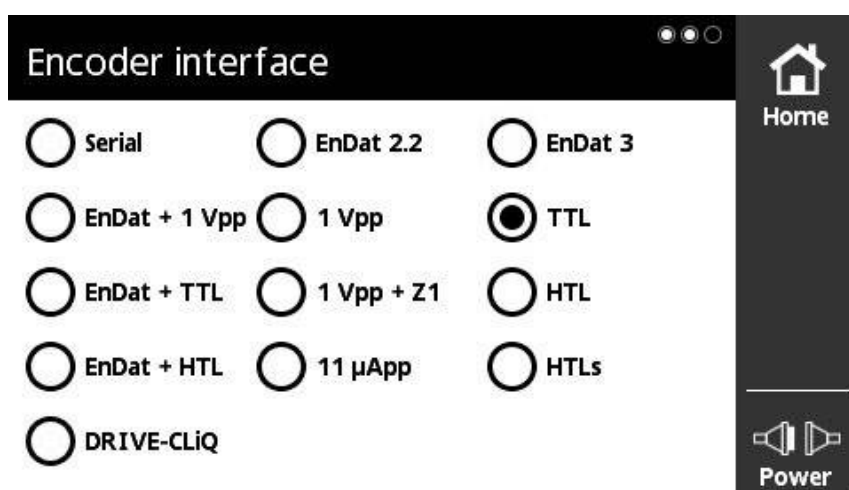

The **Encoder interface** screen

- ▶ Check your selection
- ▶ Tap **Connect**
- > The connection to the encoder is established.
- > The **Level display** screen is opened.

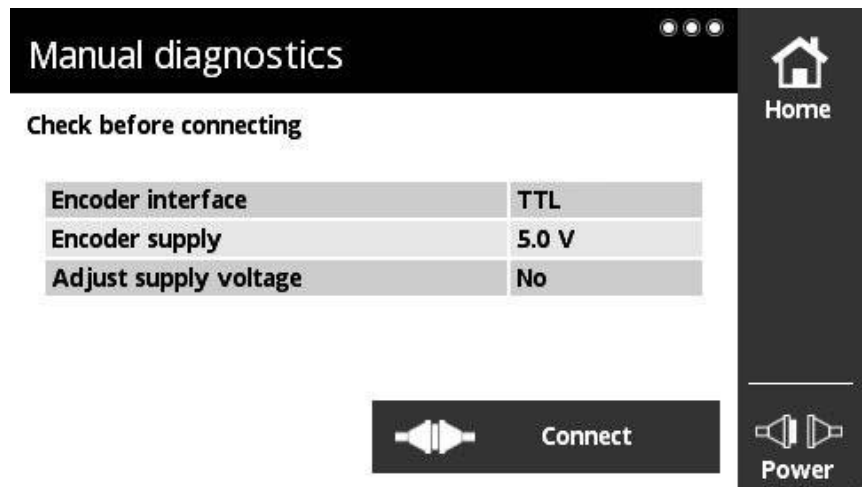

The **Manual Diagnosis** screen

Next step: "Adjusting the scanning head", Page 39

5.4.2 Adjusting the scanning head

- ▶ Swipe the **Level display** screen to the right
- ▶ The **PWT display** screen is opened.

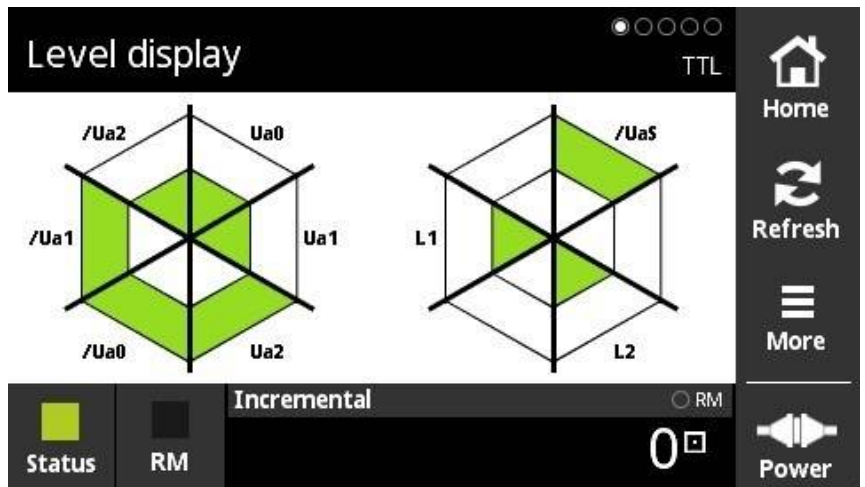

The **Level display** screen

In the **PWT display** screen, you can evaluate the incremental and reference mark signals based on the bar diagrams. HSP is automatically deactivated in the **PWT display** screen.

*) If **HSP OFF** blinks, then HSP is deactivated.

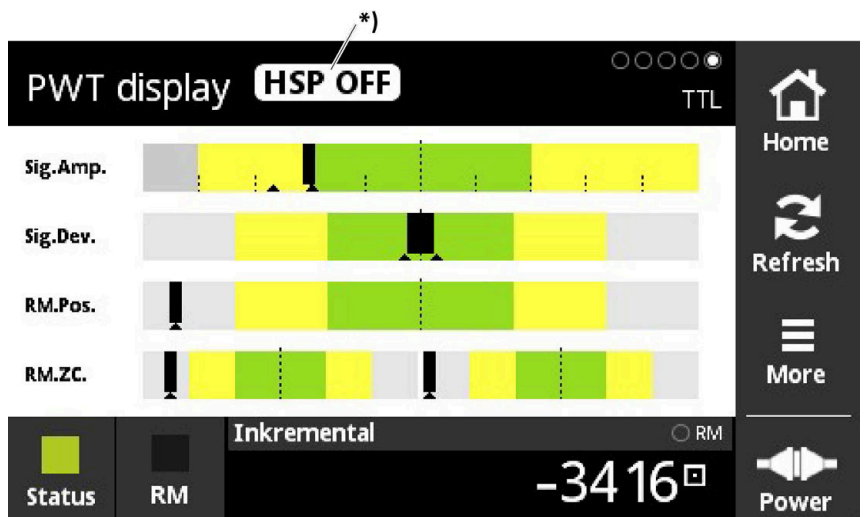

The **PWT display** screen

Setting the incremental signal

The black bar represents the current signal amplitude of the incremental signals. The farther the black bar moves to the right, the larger the signal amplitude is.

- ▶ Rotate the scanning head to set the maximum possible signal amplitude

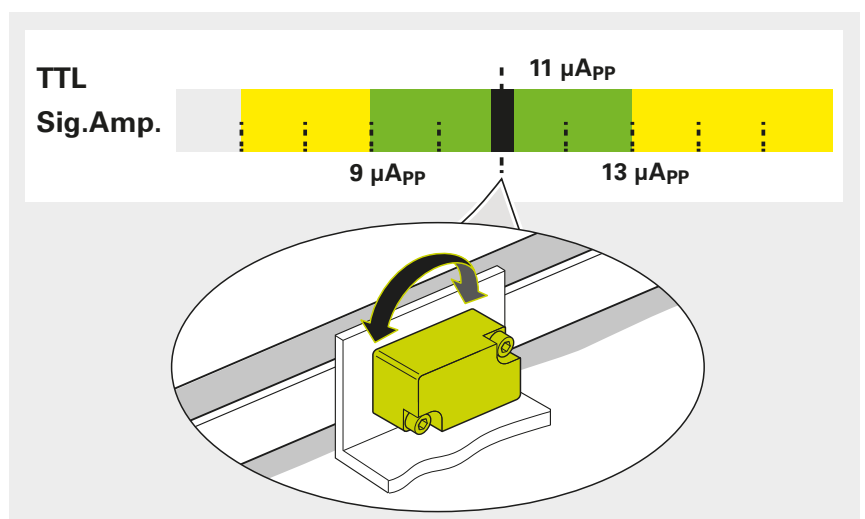

- ▶ Lightly tighten the screws



Setting the reference mark signal

- ▶ Traverse the reference mark (R) with the scanning head

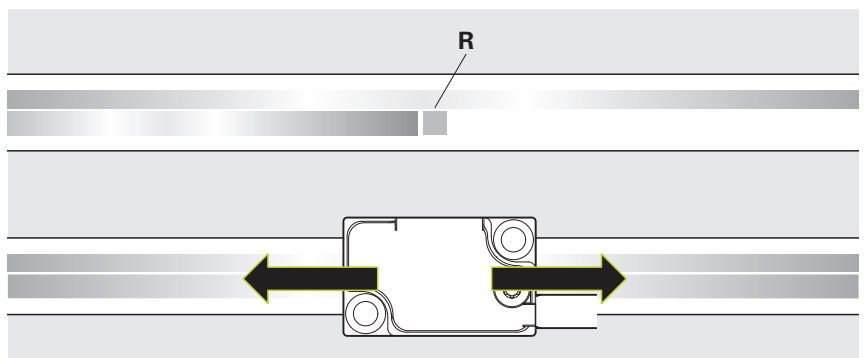

- ▶ Tap lightly to rotate the scanning head a minimum distance to set the optimal reference mark signals.

*) Green = good

***) Optimal

- ▶ Ensure that the incremental signals do not decrease

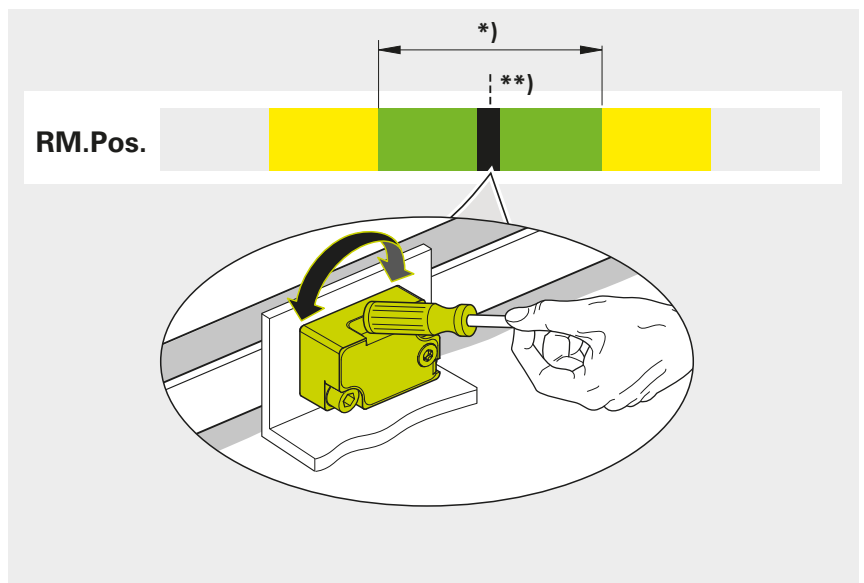

- ▶ Tighten the screws with the specified torque



5.4.3 Checking the function indicator

The function indicator permits fast and easy signal-quality checks.

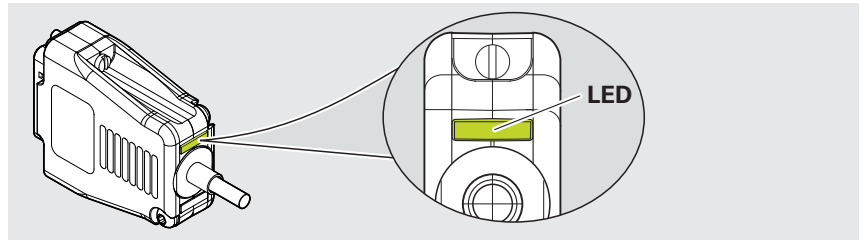

If the LED blinks green after adjustment, proceed as follows:

- ▶ Clean the measuring standard and the scanning window of the scanning head
- ▶ Check the mounting tolerance
- ▶ Repeat the adjustment

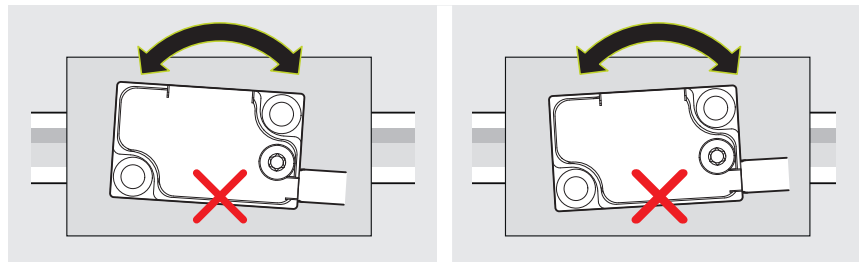

LED blinks

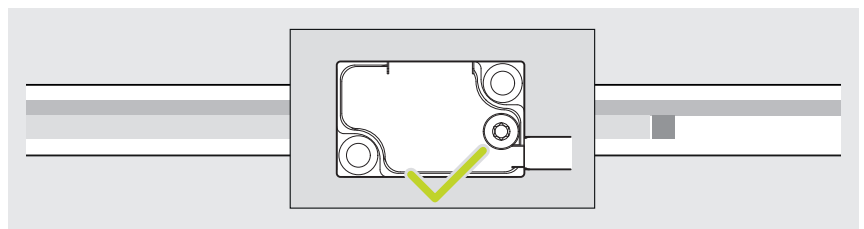

LED shines green



For more information, see the **Exposed Linear Encoders** brochure.

▶ www.heidenhain.com/documentation

▶ Enter the document ID **208960**

5.4.4 Mounting the limit plates

Notes on mounting the limit plates



The mounting of the limit plates is optional.

Limit plates make it possible to detect the limit positions and to distinguish whether the right or left limit position is crossed.

- 1 = Limit plate
- 2 = Homing track
- 3 = Reference mark
- 4 = Hole for adhesive

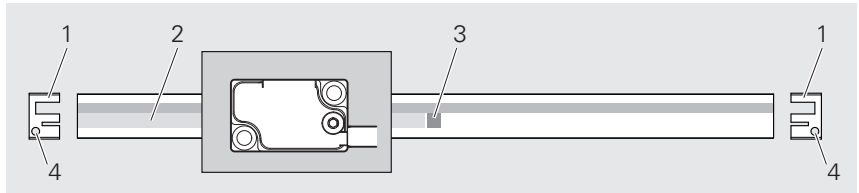

Attaching the limit plates

- ▶ Attach the limit plates to the scale

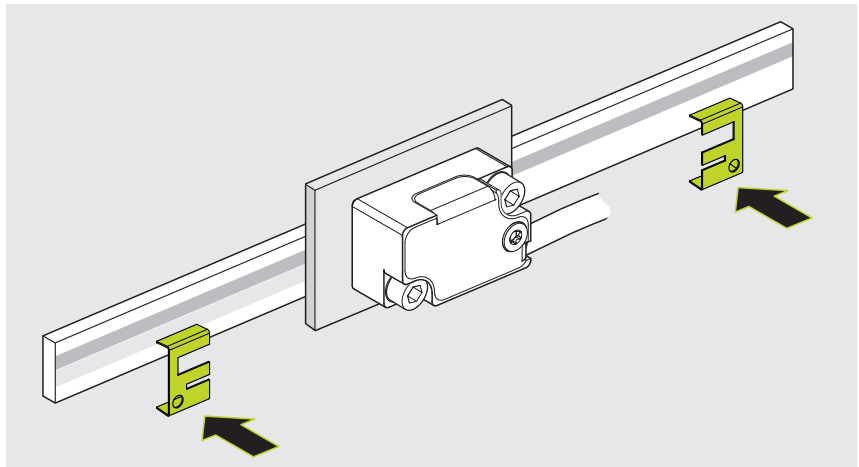

- ▶ Roughly set the desired distance

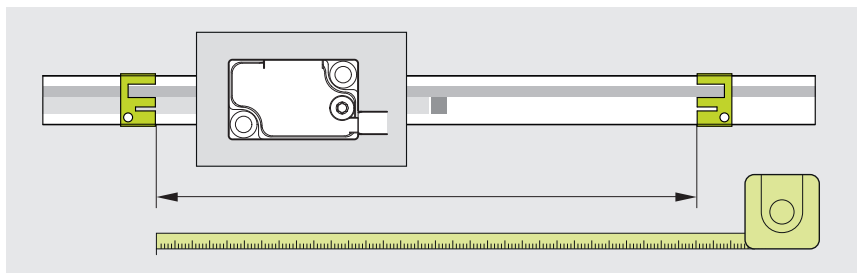

Setting the trigger points

- ▶ Swipe to switch to the **Switching signals** screen
- ▶ Traverse the reference mark with the scanning head

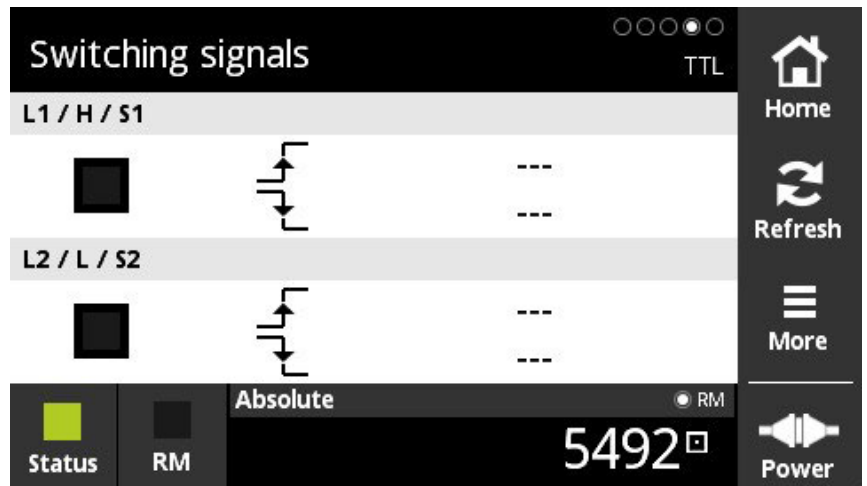

The **Switching signals** screen

- ▶ Move the scanning head over the limit plate until the PWT shows a value at position L1 or L2
(1) = Limit at left, no homing
(2) = Limit at right, homing
- ▶ Slide the limit plate to the desired position
- ▶ Move the scanning head over the limit plate again and check the value
- ▶ Repeat this procedure for the second limit plate

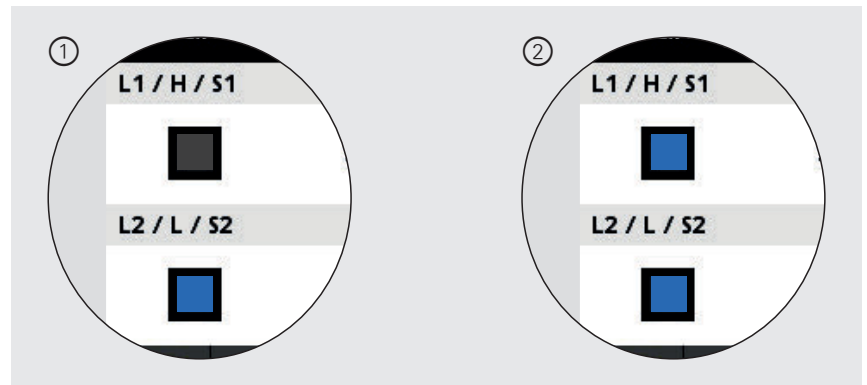

Securing the limit plates

- ▶ Press the limit plates against the scale
- ▶ Insert a small amount of adhesive into the holes for the adhesive
- ▶ Allow the adhesive to harden as appropriate for the intended operating temperature

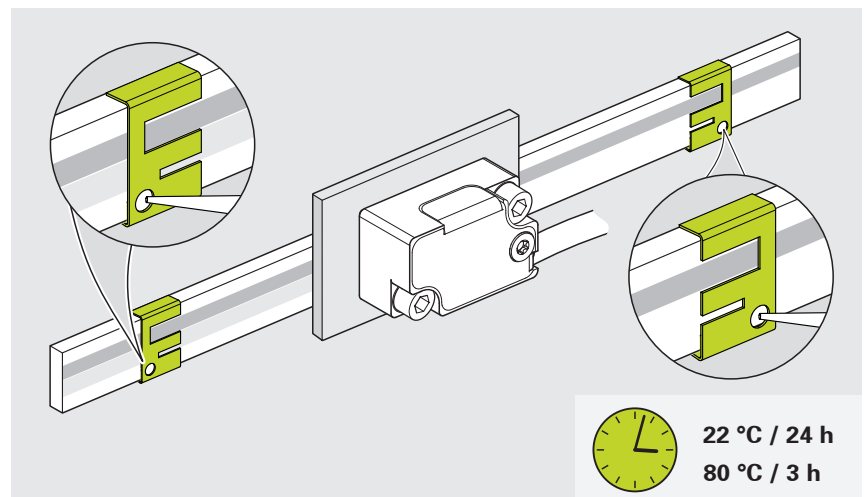

Note the specifications regarding the curing temperature and curing time.

Operating temperature	Curing temperature	Curing time
-10 °C to +30 °C	22 °C	24 hours
-10 °C to +70 °C	80 °C	3 hours

Next step: "Final steps", Page 71

5.5 Adjustment and diagnosis of LIF 48 R

5.5.1 Connecting the encoder to the PWT

Connecting the encoder

NOTICE

Property damage due to electrical stress!

Improper handling of the connecting element can cause damage to the product.

- ▶ Do not engage or disengage any connecting elements while the product is under power

- ▶ Connect the encoder to the PWT 101
- ▶ Connect the PWT 101 to the power supply

Selecting the connection

Connection options

Connecting the encoder automatically	Connecting the encoder manually
Recommended option with automatic determination of the measuring parameters.	Alternative option if the encoder cannot be connected automatically.
Page 45	Page 46

Connecting the encoder automatically

- ▶ Tap **Automatic Diagnosis** in the main menu
- > The **Automatic Diagnosis** is performed.
- > The **PWT display** screen is opened.

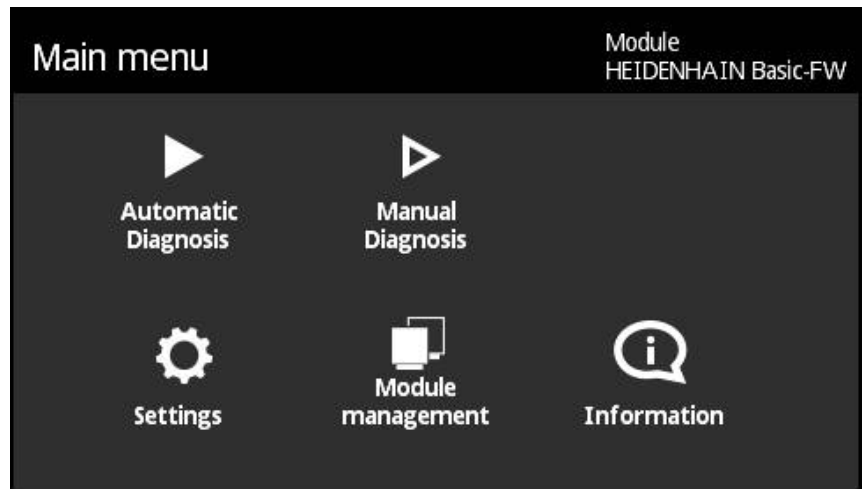

Main menu



If you cannot connect the encoder automatically, proceed as described in the **Connecting the encoder manually** chapter.

Next step: "Adjusting the scanning head", Page 48

Connecting the encoder manually

- ▶ Tap **Manual diagnostics** in the main menu
- ▶ The **Supply voltage of encoder** screen is opened.

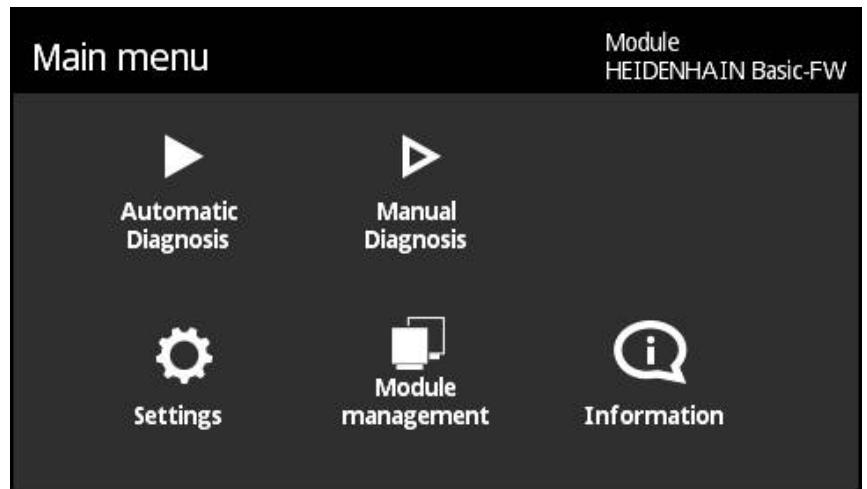

Main menu

- ▶ Select the supply voltage
- ▶ Activate the **Adjust supply voltage** checkbox, if required
- ▶ Swipe right to left
- ▶ The **Encoder interface** screen is opened.

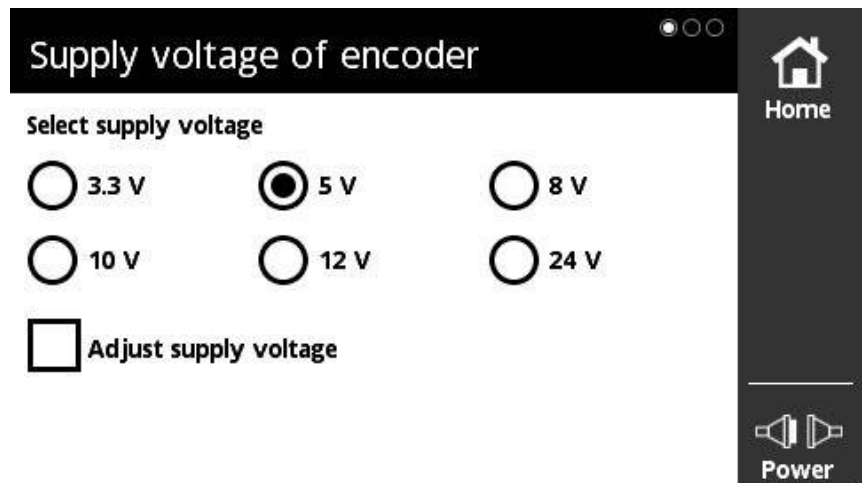

The **Supply voltage of encoder** screen

- ▶ Select the encoder interface
- ▶ Swipe right to left
- ▶ The **Manual diagnostics** screen is opened.

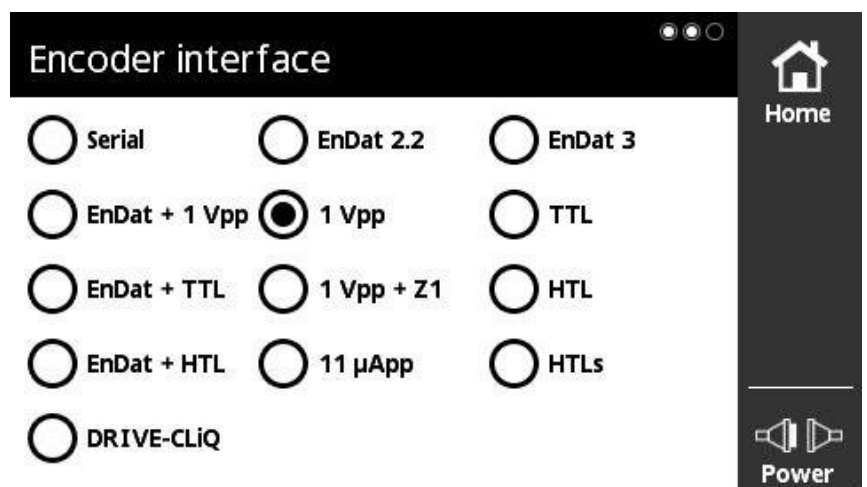

The **Encoder interface** screen

- ▶ Check your selection
- ▶ Tap **Connect**
- > The connection to the encoder is established.
- > The **PWT display** screen is opened.

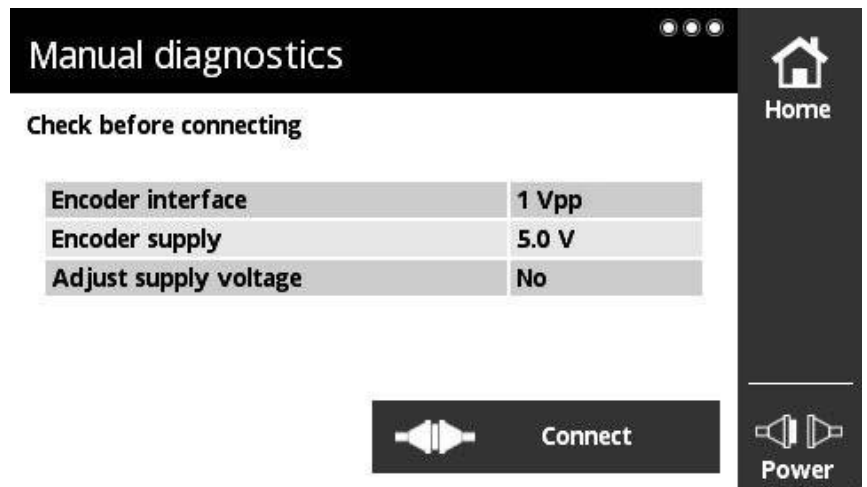

The **Manual Diagnosis** screen

Next step: "Adjusting the scanning head", Page 48

5.5.2 Adjusting the scanning head

In the **PWT display** screen, you can evaluate the incremental and reference mark signals based on the bar diagrams.

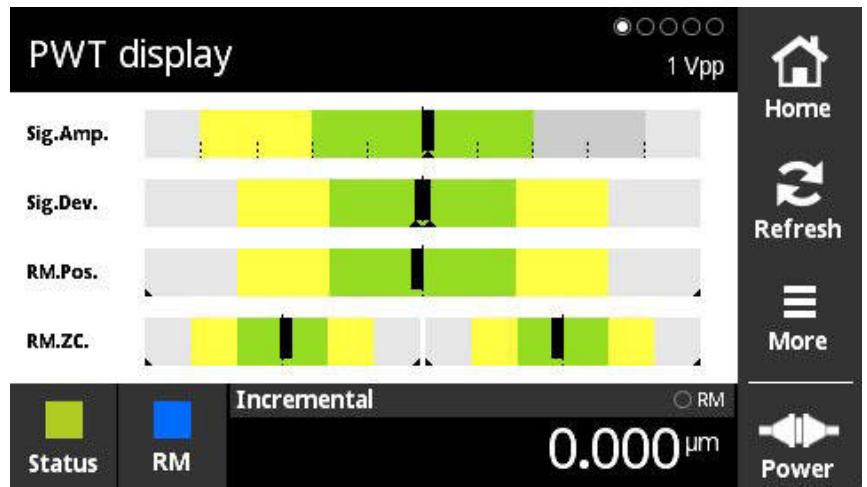

The **PWT display** screen

Deactivating HSP

Deactivate HSP to ensure optimal mechanical mounting.

- ▶ Tap **More**
- > The **More** menu is opened.
- ▶ Tap **Functions**
- > The **Function settings** screen is opened.



The Menu **More**

- ▶ Deactivate **Evaluation of incremental signals (HSP active)**
- ▶ Tap **Back**
- > HSP is deactivated.
- > The **PWT display** screen is opened.

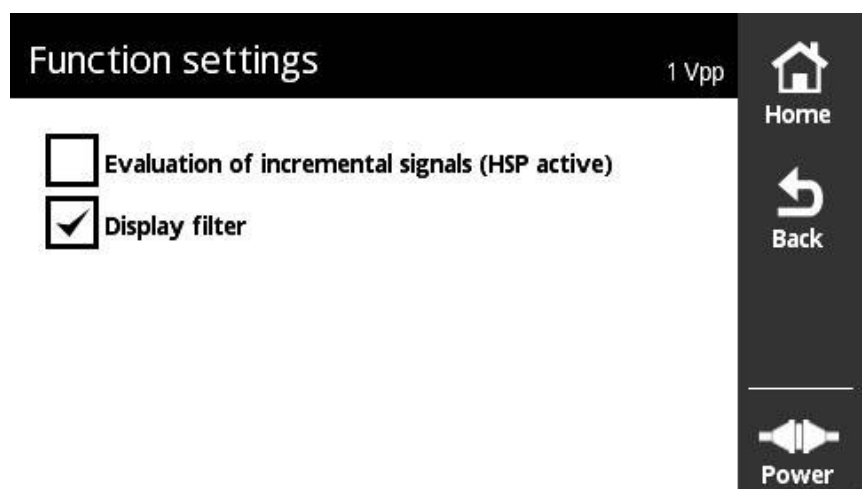

The **Function settings** screen

*) If **HSP OFF** blinks, then HSP is deactivated.

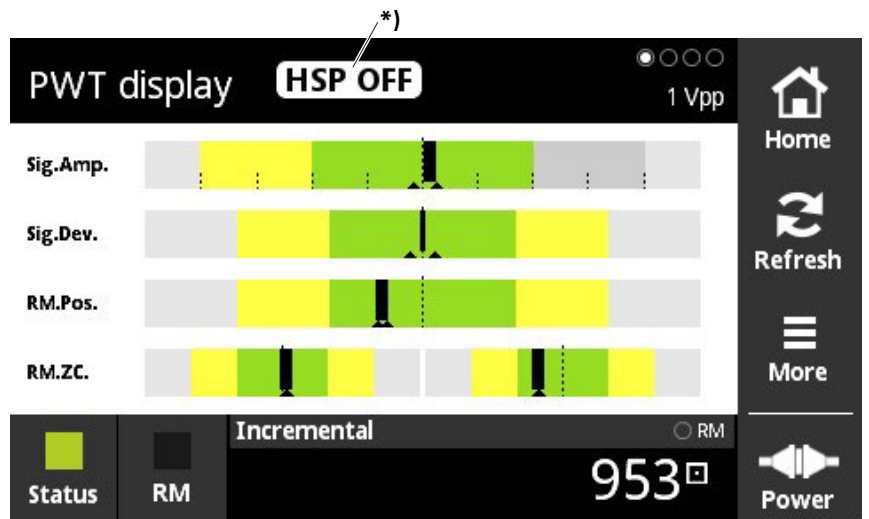

The PWT display screen

Setting the output signals

The black bar represents the current output signals.

- ▶ Rotate the scanning head to set the output signals to 1 V_{PP}

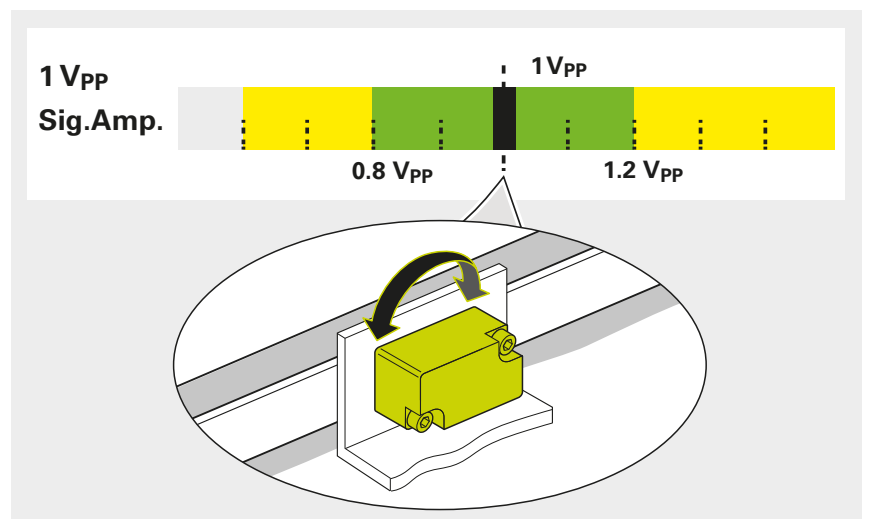

- ▶ Lightly tighten the screws



Setting the reference mark signal

- ▶ Traverse the reference mark (R) with the scanning head

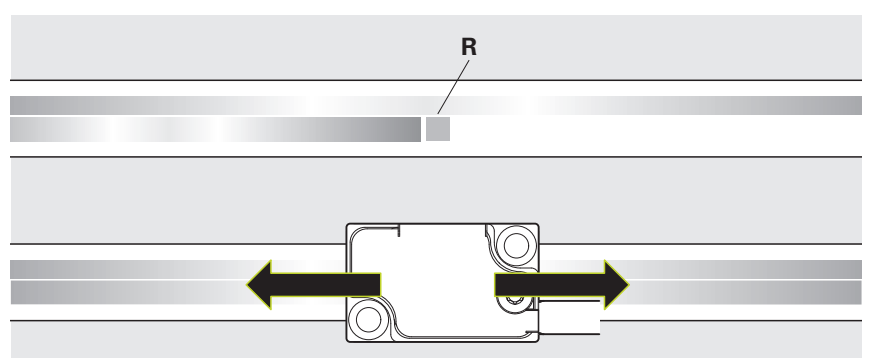

- ▶ Tap lightly to rotate the scanning head a minimum distance to set the optimal reference mark signals.

*) Green = good

***) Optimal

- ▶ Ensure that the incremental signals do not decrease

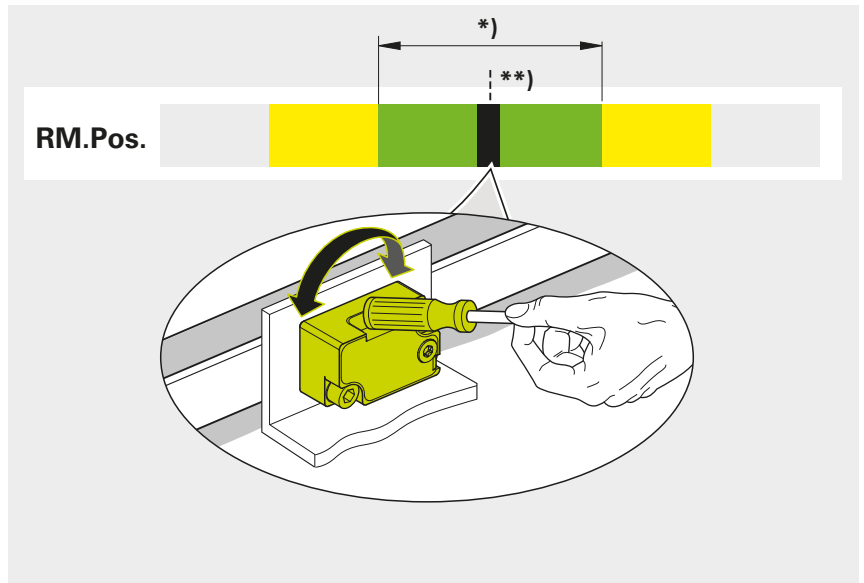

- ▶ Tighten the screws with the specified torque



5.5.3 Checking the function indicator

The function indicator permits fast and easy signal-quality checks.

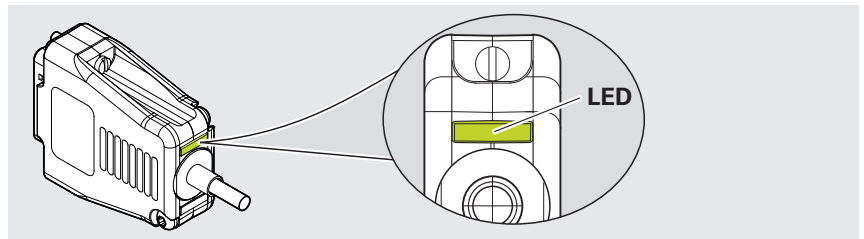

If the LED blinks green after adjustment, proceed as follows:

- ▶ Clean the measuring standard and the scanning window of the scanning head
- ▶ Check the mounting tolerance
- ▶ Repeat the adjustment

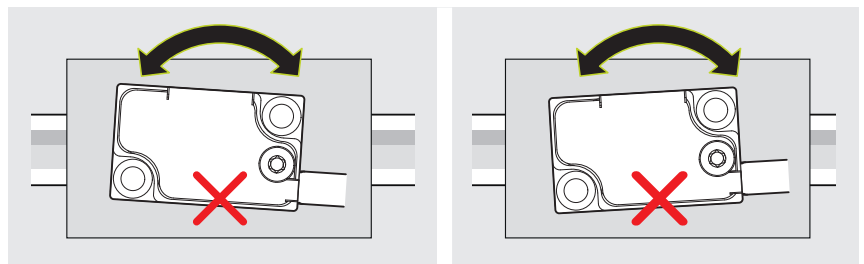

LED blinks

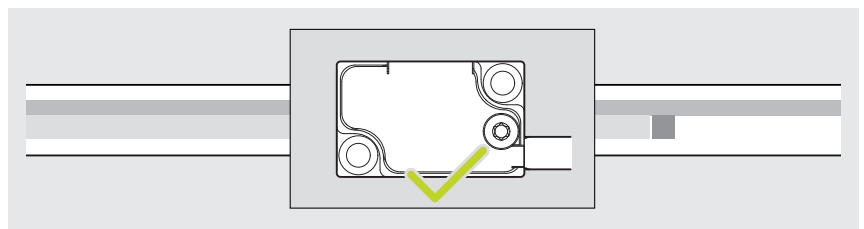

LED shines green



For more information, see the **Exposed Linear Encoders** brochure.

▶ www.heidenhain.com/documentation

▶ Enter the document ID **208960**

5.5.4 Mounting the limit plates

Notes on mounting the limit plates

i The mounting of the limit plates is optional.
Limit plates make it possible to detect the limit positions and to distinguish whether the right or left limit position is crossed.

- 1 = Limit plate
- 2 = Homing track
- 3 = Reference mark
- 4 = Hole for adhesive

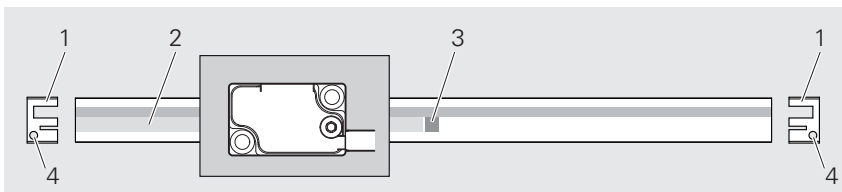

Attaching the limit plates

- ▶ Attach the limit plates to the scale

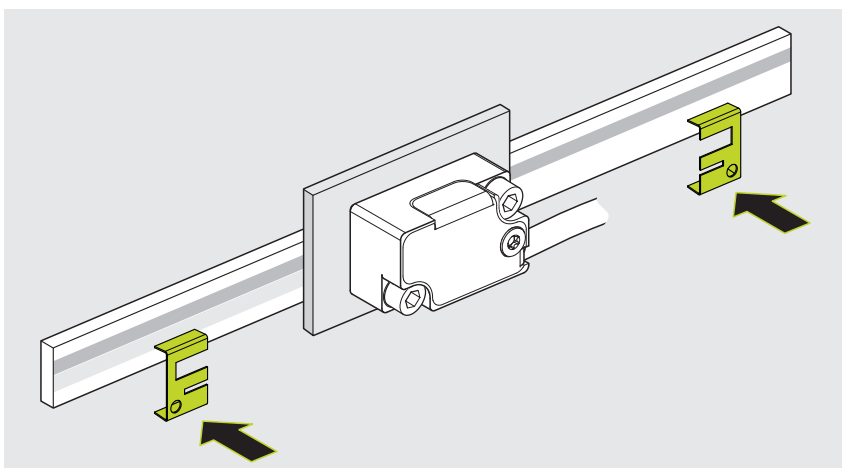

- ▶ Roughly set the desired distance

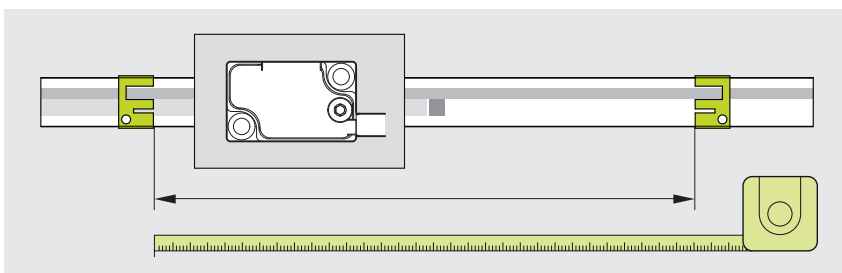

Setting the trigger points

- ▶ Swipe to switch to the **Switching signals** screen
- ▶ Traverse the reference mark with the scanning head

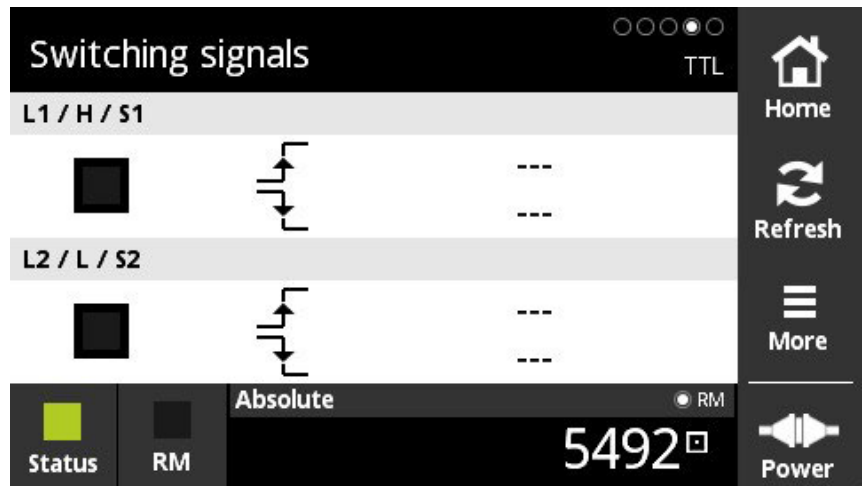

The **Switching signals** screen

- ▶ Move the scanning head over the limit plate until the PWT shows a value at position L1 or L2
(1) = Limit at left, no homing
(2) = Limit at right, homing
- ▶ Slide the limit plate to the desired position
- ▶ Move the scanning head over the limit plate again and check the value
- ▶ Repeat this procedure for the second limit plate

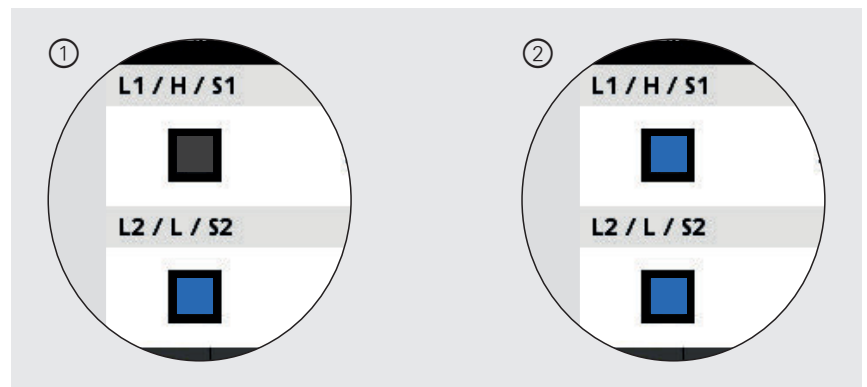

Securing the limit plates

- ▶ Press the limit plates against the scale
- ▶ Insert a small amount of adhesive into the holes for the adhesive
- ▶ Allow the adhesive to harden as appropriate for the intended operating temperature

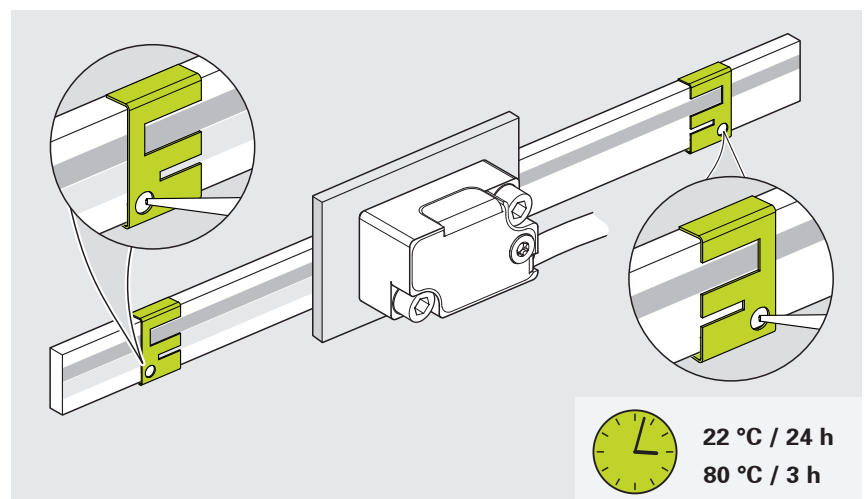

Note the specifications regarding the curing temperature and curing time.

Operating temperature	Curing temperature	Curing time
-10 °C to +30 °C	22 °C	24 hours
-10 °C to +70 °C	80 °C	3 hours

Next step: "Final steps", Page 71

5.6 Adjustment and diagnosis of LIF 47 V

5.6.1 Connecting the encoder to the PWT

Connecting the encoder

NOTICE

Property damage due to electrical stress!

Improper handling of the connecting element can cause damage to the product.

- ▶ Do not engage or disengage any connecting elements while the product is under power

- ▶ Connect the encoder to the PWT 101
- ▶ Connect the PWT 101 to the power supply

Selecting the connection

Connection options

Connecting the encoder automatically	Connecting the encoder manually
Recommended option with automatic determination of the measuring parameters. Page 55	Alternative option if the encoder cannot be connected automatically. Page 56

Connecting the encoder automatically

- ▶ Tap **Automatic Diagnosis** in the main menu
- > The **Automatic Diagnosis** is performed.
- > The **Level display** screen is opened.

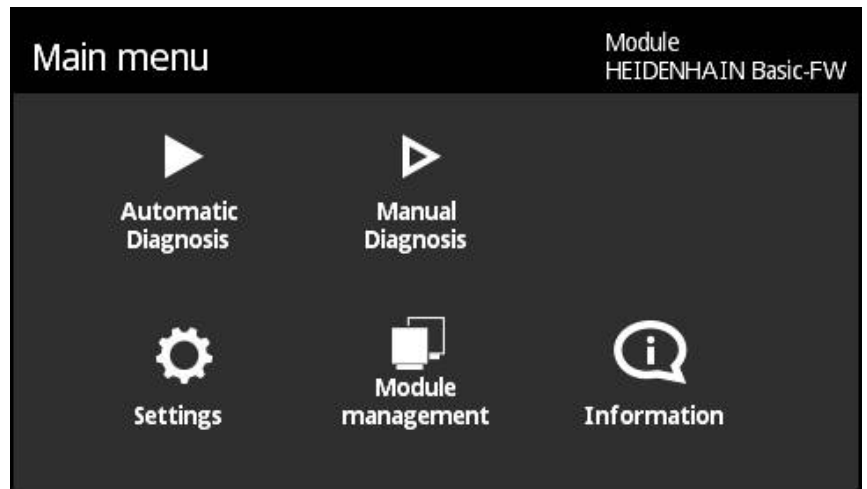

Main menu



If you cannot connect the encoder automatically, proceed as described in the **Connecting the encoder manually** chapter.

Next step: "Adjusting the scanning head", Page 58

Connecting the encoder manually

- ▶ Tap **Manual diagnostics** in the main menu
- ▶ The **Supply voltage of encoder** screen is opened.

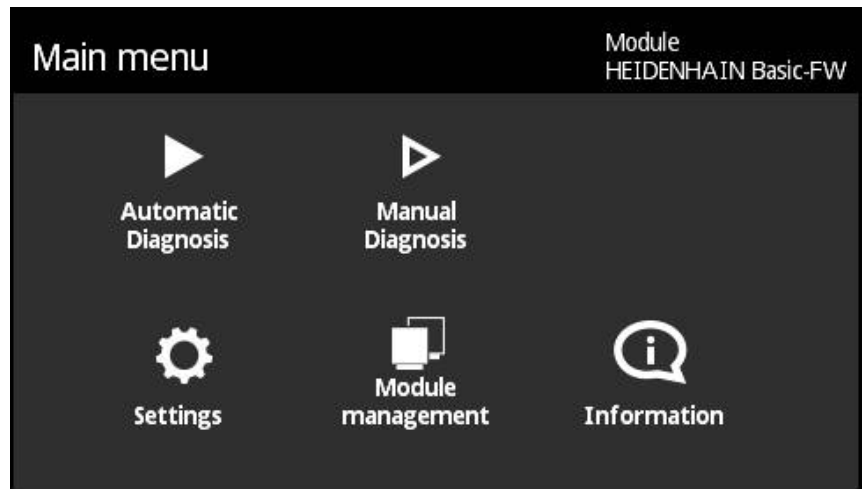

Main menu

- ▶ Select the supply voltage
- ▶ Activate the **Adjust supply voltage** checkbox, if required
- ▶ Swipe right to left
- ▶ The **Encoder interface** screen is opened.

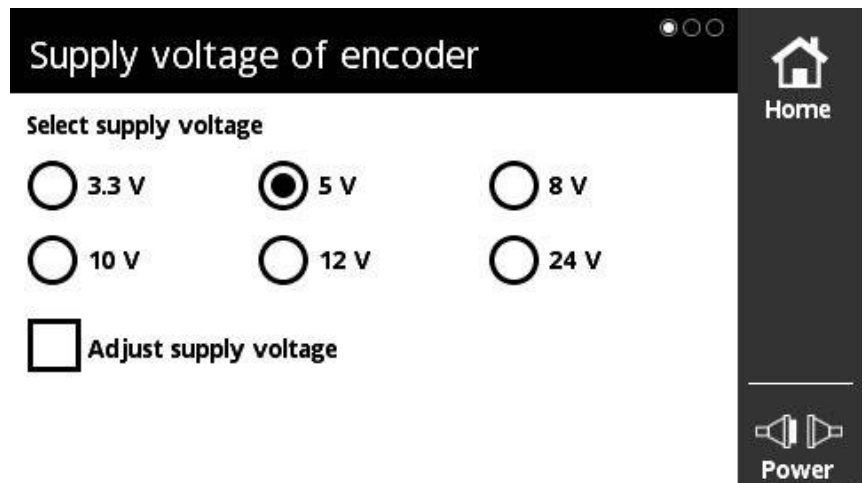

The **Supply voltage of encoder** screen

- ▶ Select the encoder interface
- ▶ Swipe right to left
- ▶ The **Manual diagnostics** screen is opened.

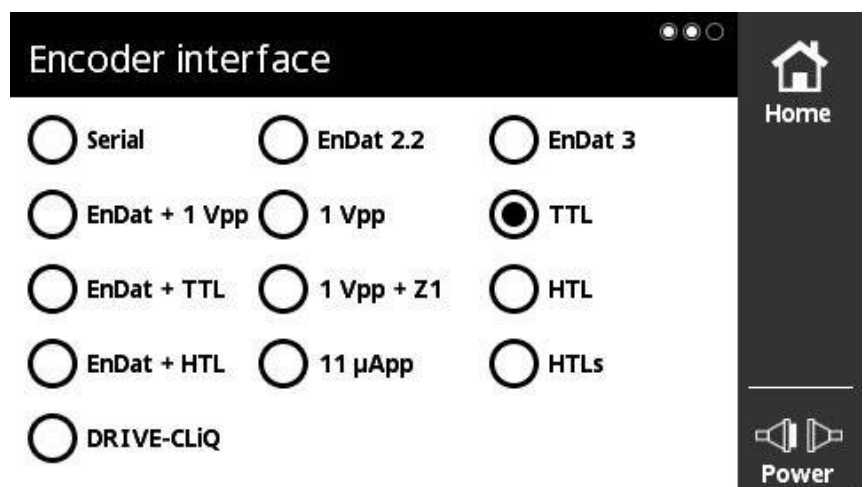

The **Encoder interface** screen

- ▶ Check your selection
- ▶ Tap **Connect**
- > The connection to the encoder is established.
- > The **Level display** screen is opened.

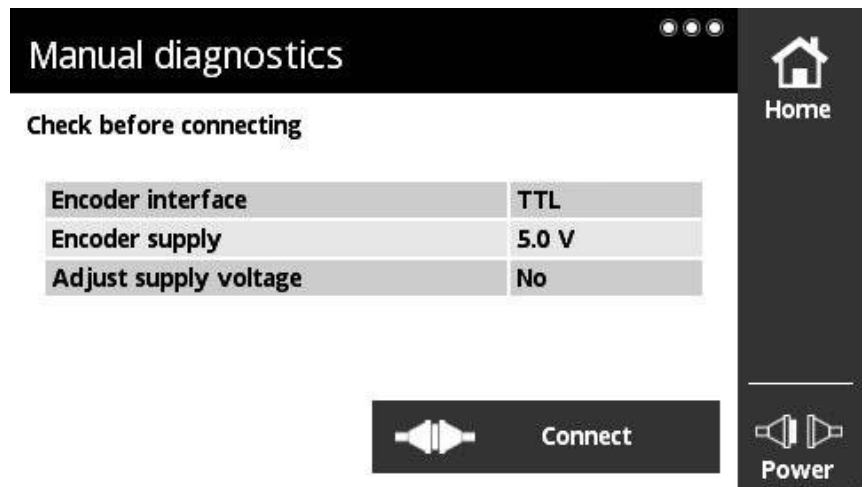

The **Manual Diagnosis** screen

Next step: "Adjusting the scanning head", Page 58

5.6.2 Adjusting the scanning head

- ▶ Swipe the **Level display** screen to the right
- ▶ The **PWT display** screen is opened.

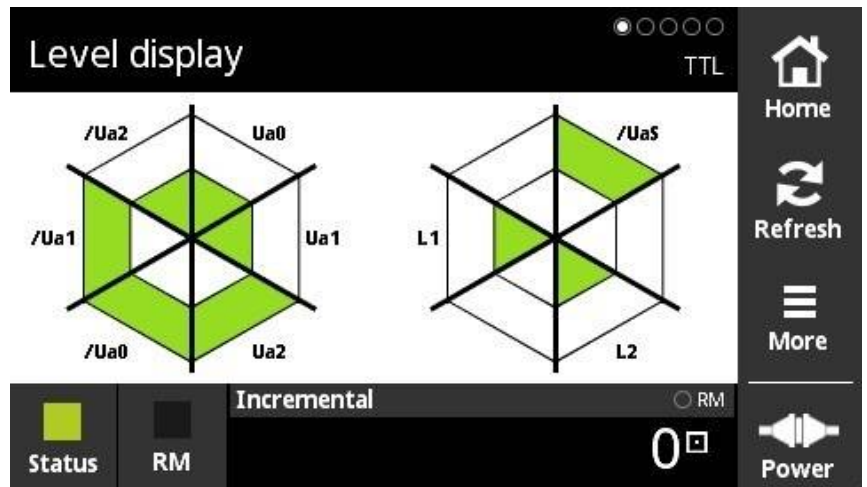

The **Level display** screen

In the **PWT display** screen, you can evaluate the incremental and reference mark signals based on the bar diagrams. HSP is automatically deactivated in the **PWT display** screen.

- *) If **HSP OFF** blinks, then HSP is deactivated.

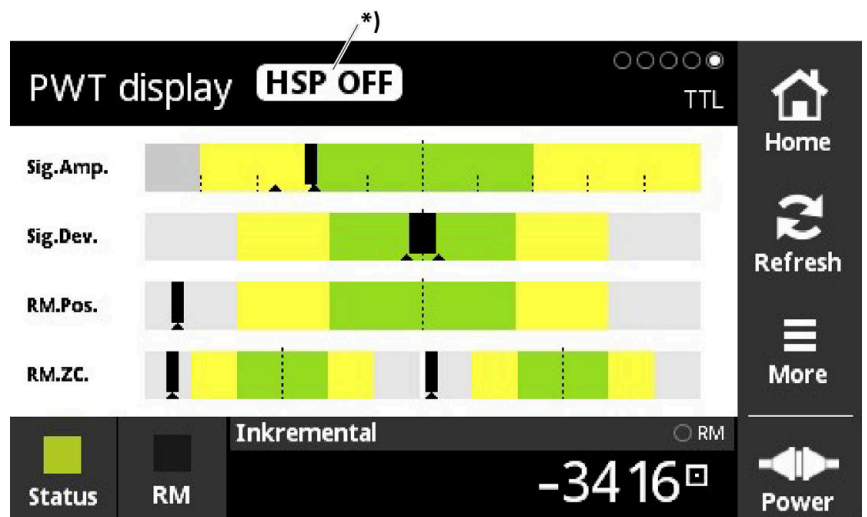

The **PWT display** screen

Setting the incremental signal

The black bar represents the current signal amplitude of the incremental signals. The farther the black bar moves to the right, the larger the signal amplitude is.

- ▶ Rotate the scanning head to set the maximum possible signal amplitude

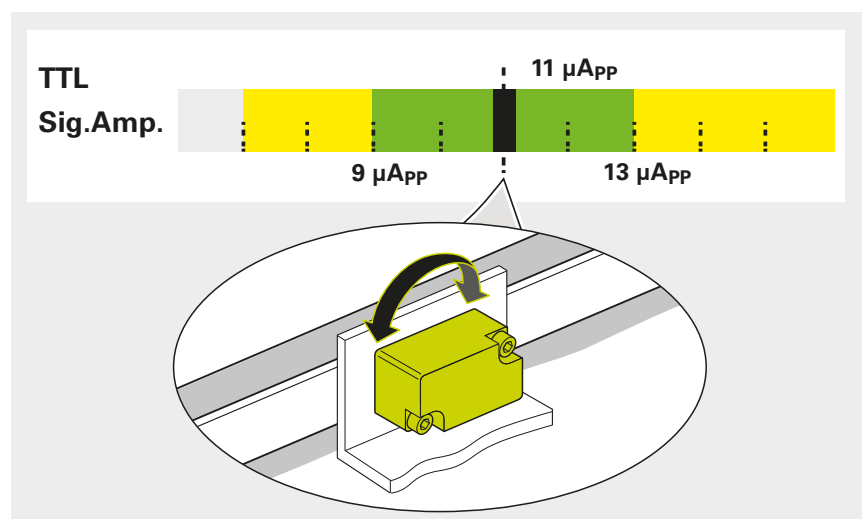

- ▶ Lightly tighten the screws



Setting the reference mark signal

- ▶ Traverse the reference mark (R) with the scanning head

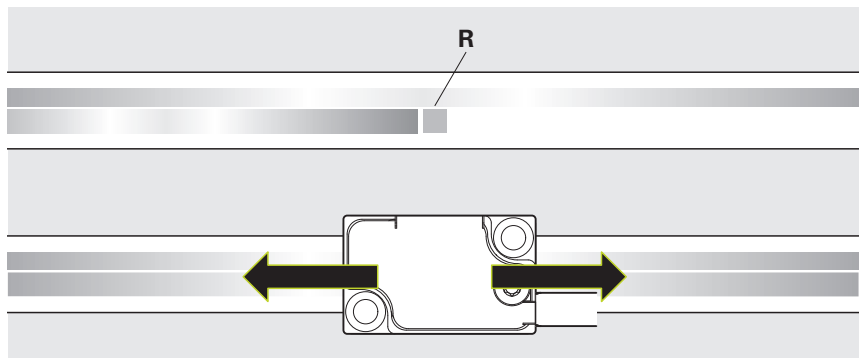

- ▶ Tap lightly to rotate the scanning head a minimum distance to set the optimal reference mark signals.

*) Green = good

***) Optimal

- ▶ Ensure that the incremental signals do not decrease

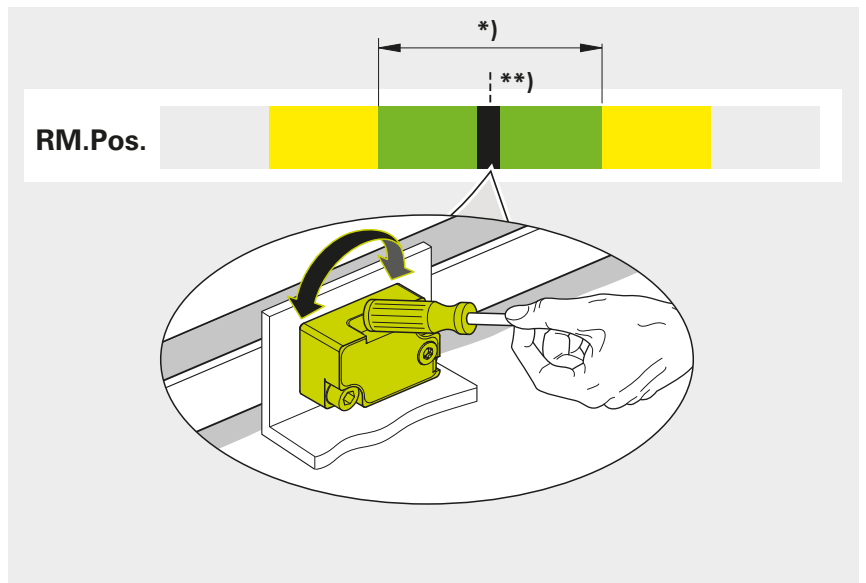

- ▶ Tighten the screws with the specified torque



5.6.3 Mounting the limit plates

Notes on mounting the limit plates

i The mounting of the limit plates is optional.
Limit plates make it possible to detect the limit positions and to distinguish whether the right or left limit position is crossed.

- 1 = Limit plate
- 2 = Homing track
- 3 = Reference mark
- 4 = Hole for adhesive

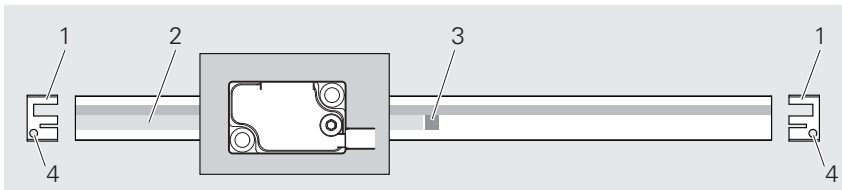

Attaching the limit plates

- ▶ Attach the limit plates to the scale

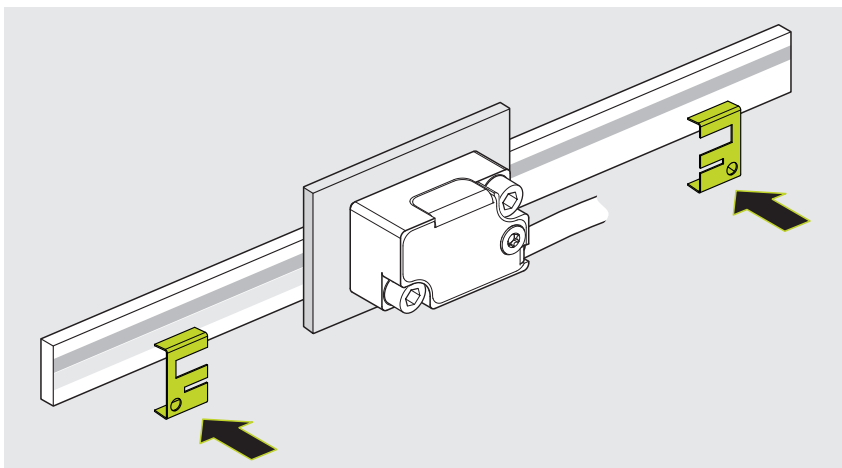

- ▶ Roughly set the desired distance

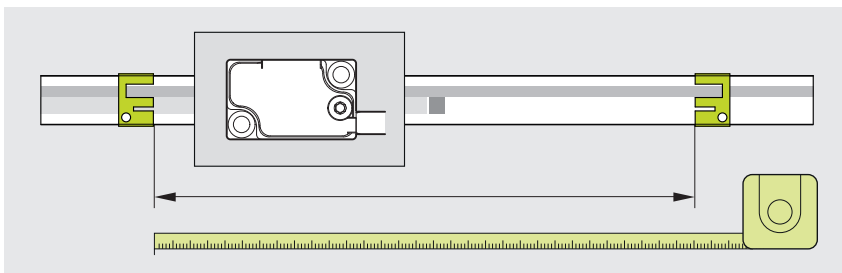

Setting the trigger points

- ▶ Swipe to switch to the **Switching signals** screen
- ▶ Traverse the reference mark with the scanning head

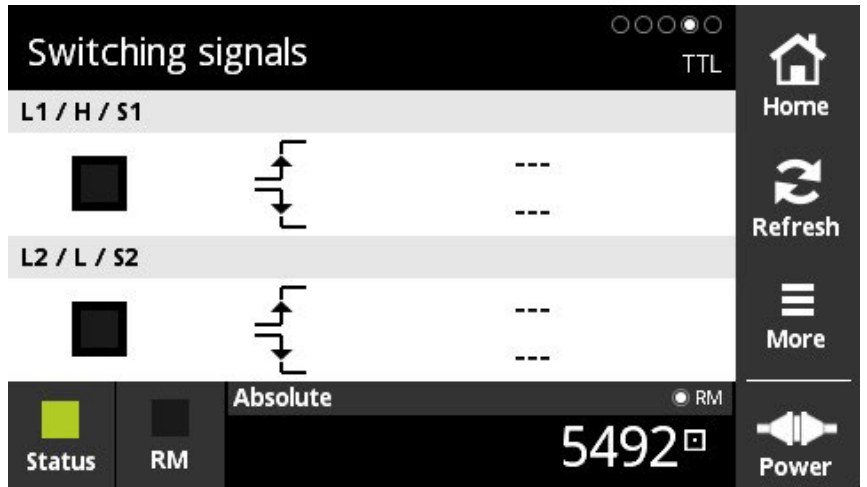

The **Switching signals** screen

- ▶ Move the scanning head over the limit plate until the PWT shows a value at position L1 or L2
(1) = Limit at left, no homing
(2) = Limit at right, homing
- ▶ Slide the limit plate to the desired position
- ▶ Move the scanning head over the limit plate again and check the value
- ▶ Repeat this procedure for the second limit plate

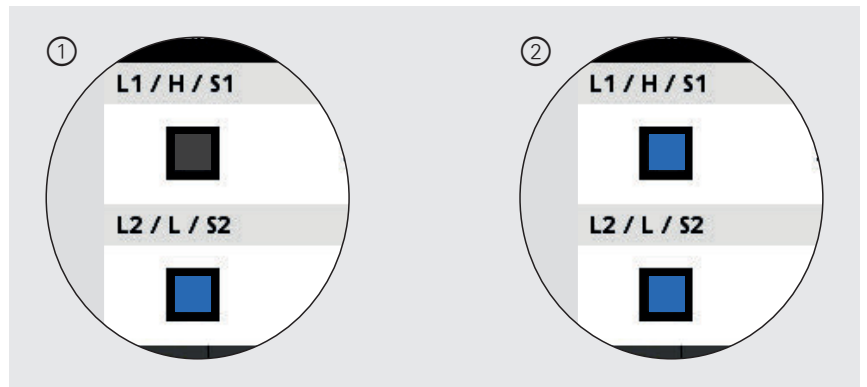

Securing the limit plates

- ▶ Press the limit plates against the scale
- ▶ Insert a small amount of adhesive into the holes for the adhesive
- ▶ Allow the adhesive to harden as appropriate for the intended operating temperature

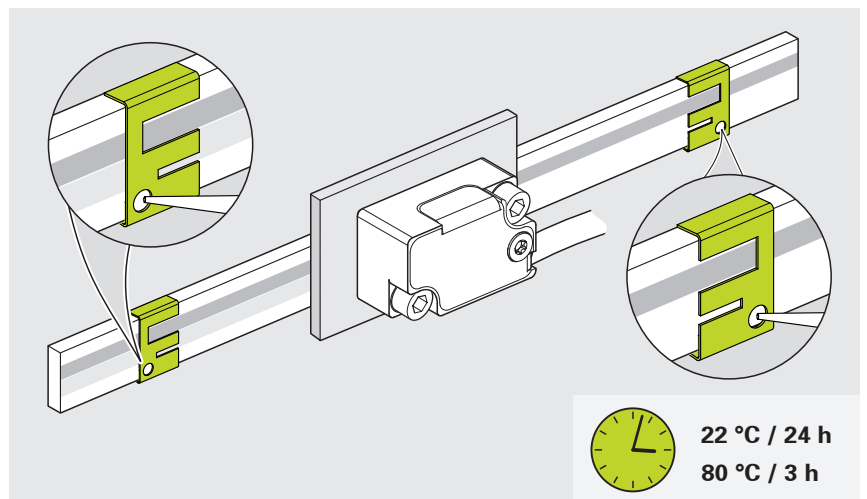

Note the specifications regarding the curing temperature and curing time.

Operating temperature	Curing temperature	Curing time
-10 °C to +30 °C	22 °C	24 hours
-10 °C to +70 °C	80 °C	3 hours

Next step: "Final steps", Page 71

5.7 Adjustment and diagnosis of LIF 48 V, LIF 48 U

5.7.1 Connecting the encoder to the PWT

Connecting the encoder

NOTICE

Property damage due to electrical stress!

Improper handling of the connecting element can cause damage to the product.

- ▶ Do not engage or disengage any connecting elements while the product is under power

- ▶ Connect the encoder to the PWT 101
- ▶ Connect the PWT 101 to the power supply

Selecting the connection

Connection options

Connecting the encoder automatically	Connecting the encoder manually
Recommended option with automatic determination of the measuring parameters.	Alternative option if the encoder cannot be connected automatically.
Page 63	Page 64

Connecting the encoder automatically

- ▶ Tap **Automatic Diagnosis** in the main menu
- > The **Automatic Diagnosis** is performed.
- > The **PWT display** screen is opened.

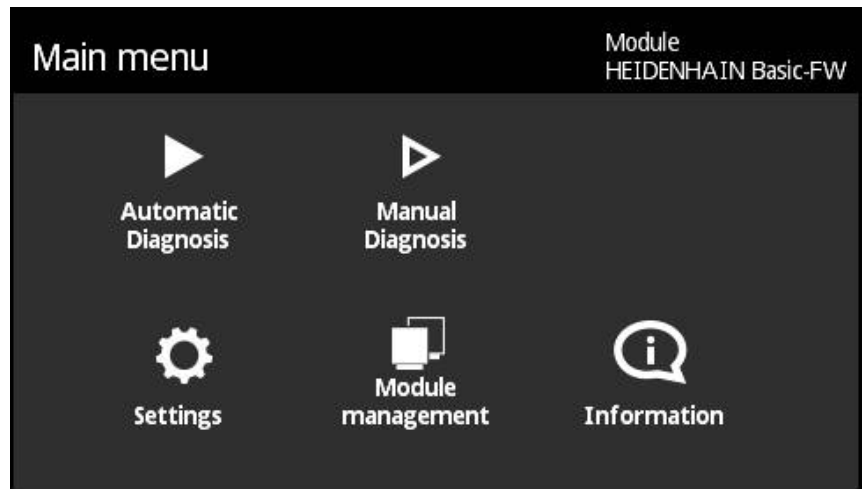

Main menu



If you cannot connect the encoder automatically, proceed as described in the **Connecting the encoder manually** chapter.

Next step: "Adjusting the scanning head", Page 66

Connecting the encoder manually

- ▶ Tap **Manual diagnostics** in the main menu
- ▶ The **Supply voltage of encoder** screen is opened.

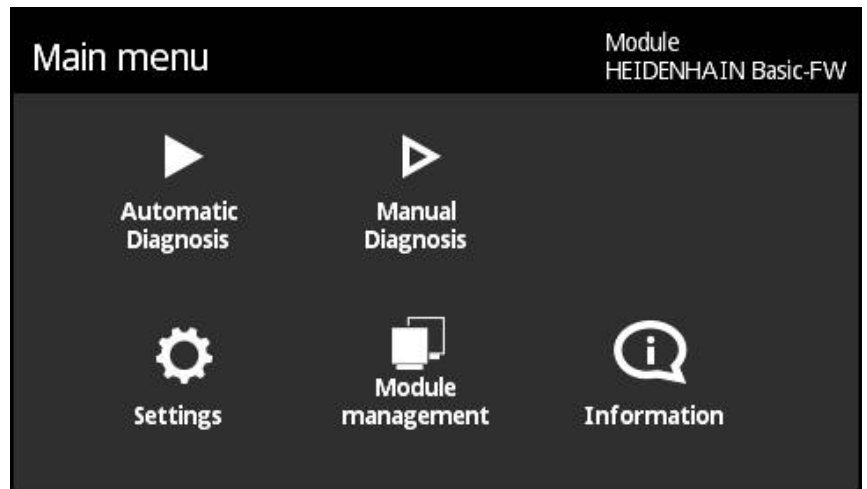

Main menu

- ▶ Select the supply voltage
- ▶ Activate the **Adjust supply voltage** checkbox, if required
- ▶ Swipe right to left
- ▶ The **Encoder interface** screen is opened.

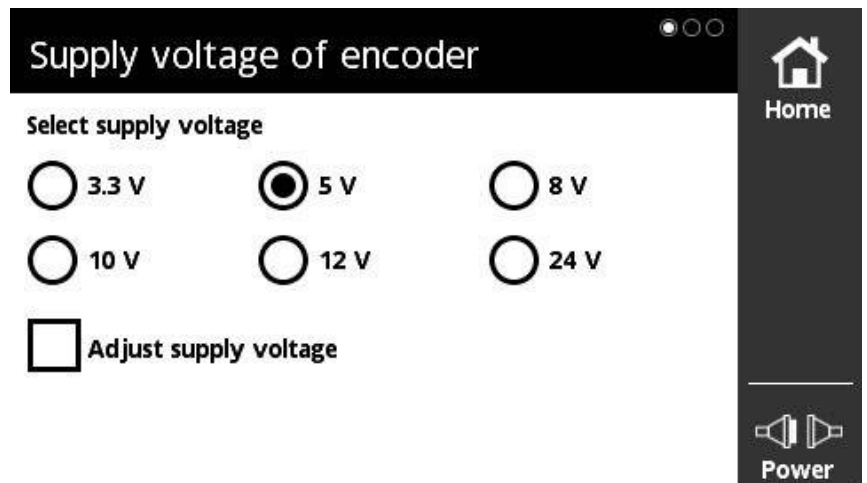

The **Supply voltage of encoder** screen

- ▶ Select the encoder interface
- ▶ Swipe right to left
- ▶ The **Manual diagnostics** screen is opened.

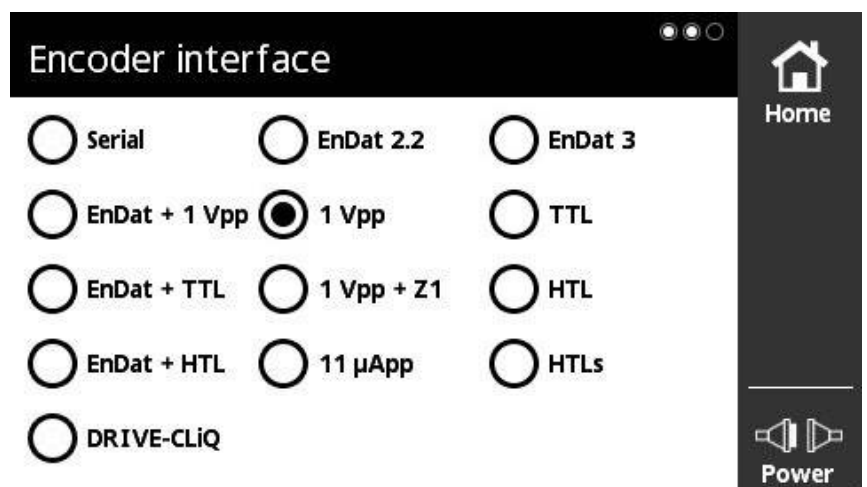

The **Encoder interface** screen

- ▶ Check your selection
- ▶ Tap **Connect**
- > The connection to the encoder is established.
- > The **PWT display** screen is opened.

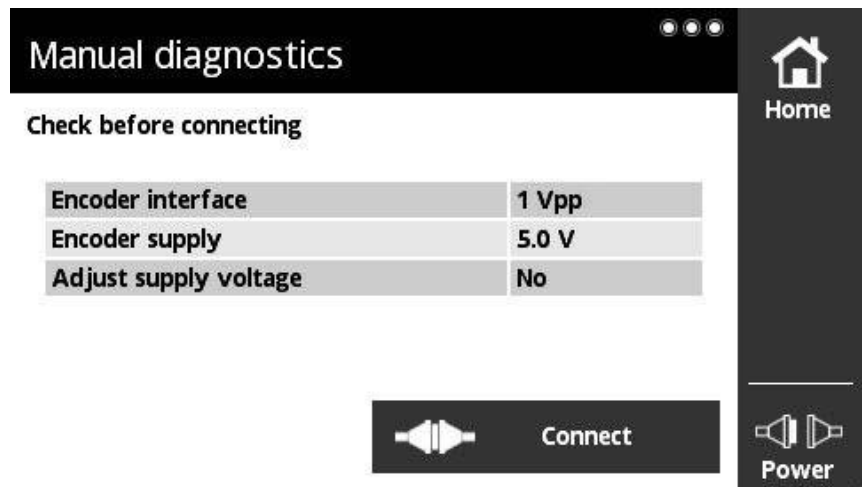

The **Manual Diagnosis** screen

Next step: "Adjusting the scanning head", Page 66

5.7.2 Adjusting the scanning head

In the **PWT display** screen, you can evaluate the incremental and reference mark signals based on the bar diagrams.

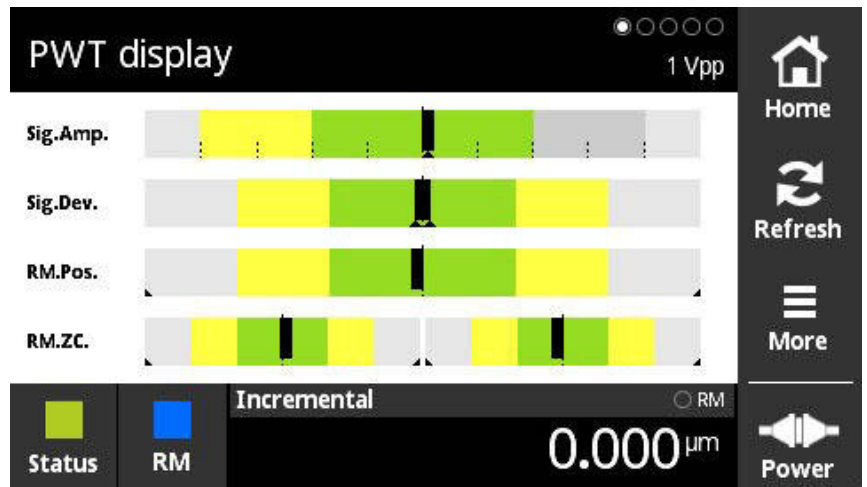

The **PWT display** screen

Deactivating HSP

Deactivate HSP to ensure optimal mechanical mounting.

- ▶ Tap **More**
- > The **More** menu is opened.
- ▶ Tap **Functions**
- > The **Function settings** screen is opened.

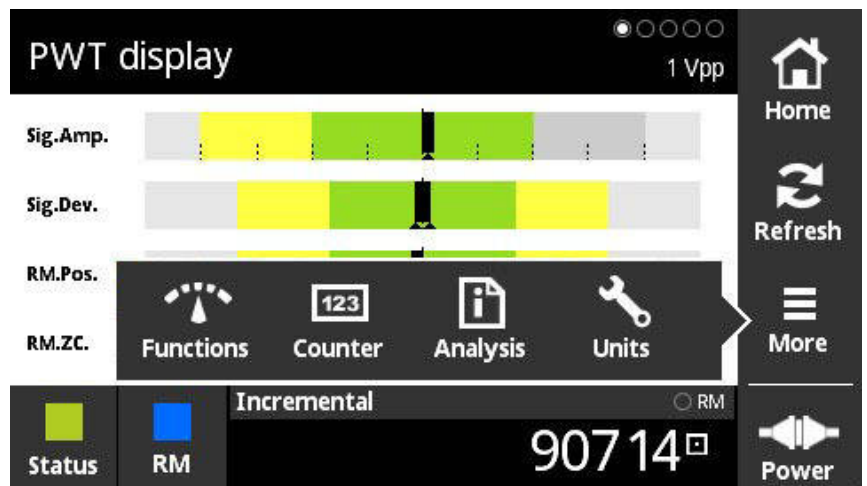

The Menu **More**

- ▶ Deactivate **Evaluation of incremental signals (HSP active)**
- ▶ Tap **Back**
- > HSP is deactivated.
- > The **PWT display** screen is opened.

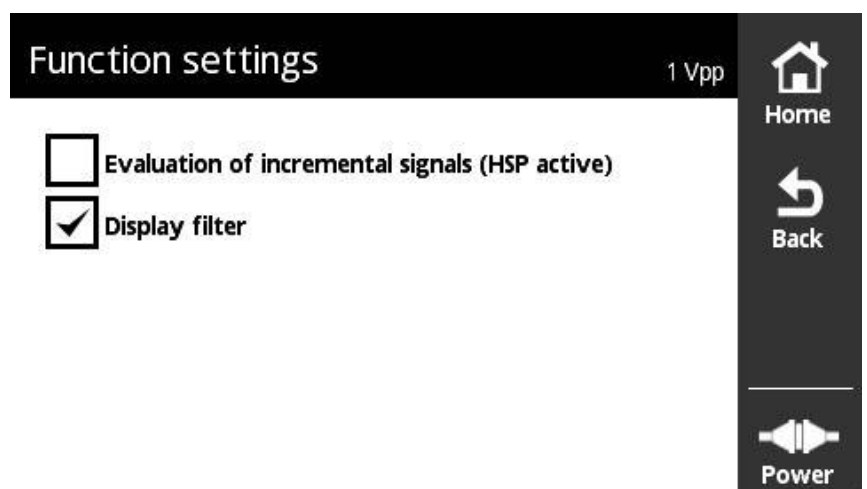

The **Function settings** screen

*) If **HSP OFF** blinks, then HSP is deactivated.

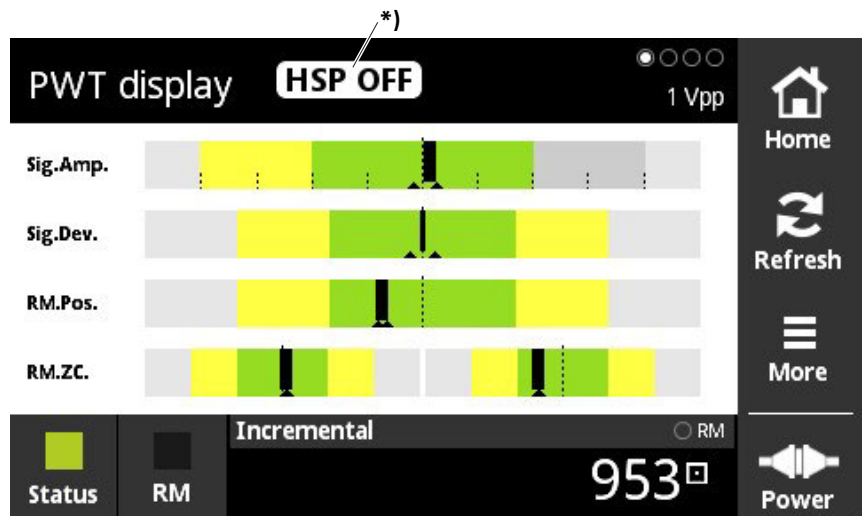

The PWT display screen

Setting the output signals

The black bar represents the current output signals.

- ▶ Rotate the scanning head to set the output signals to 1 V_{PP}

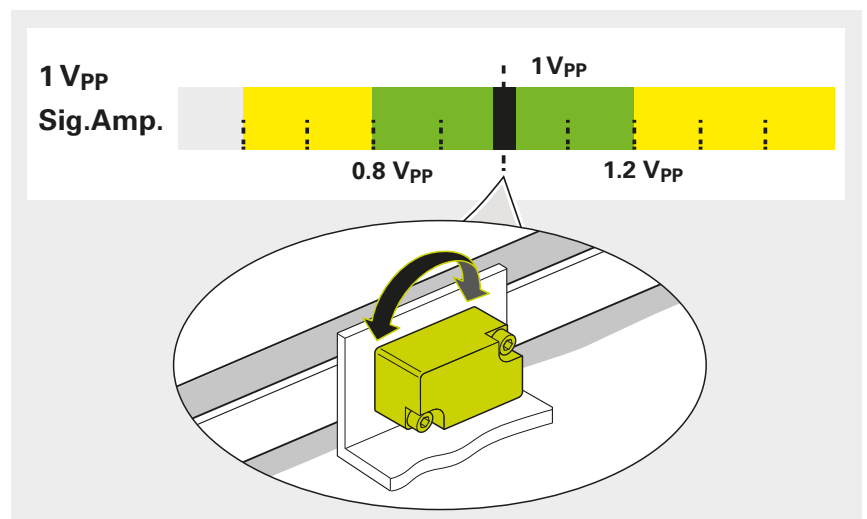

- ▶ Lightly tighten the screws



Setting the reference mark signal

- ▶ Traverse the reference mark (R) with the scanning head

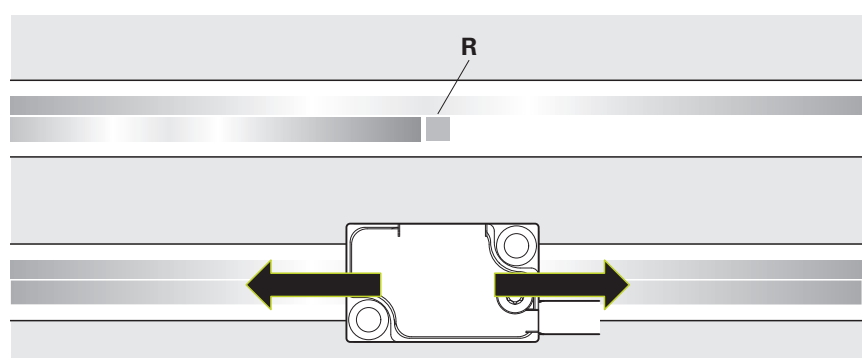

- ▶ Tap lightly to rotate the scanning head a minimum distance to set the optimal reference mark signals.

*) Green = good

***) Optimal

- ▶ Ensure that the incremental signals do not decrease

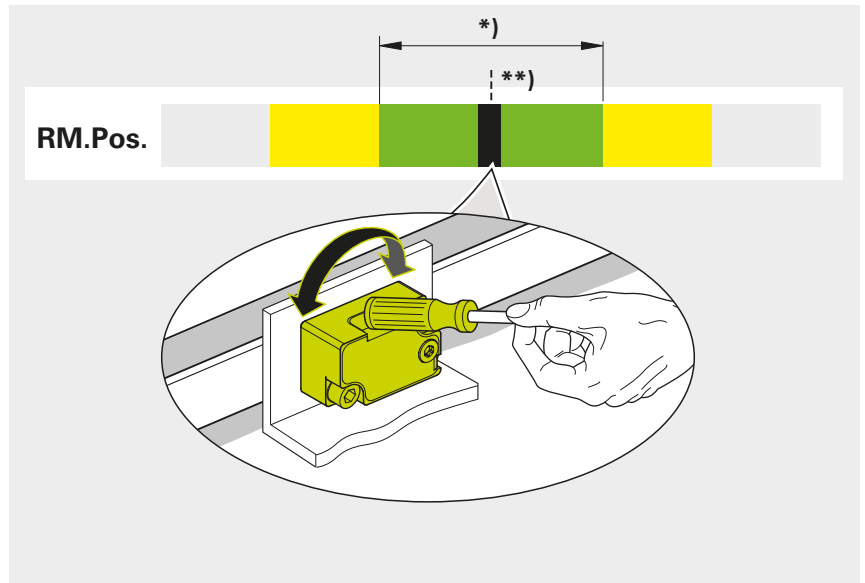

- ▶ Tighten the screws with the specified torque



5.7.3 Mounting the limit plates

Notes on mounting the limit plates



The mounting of the limit plates is optional.

Limit plates make it possible to detect the limit positions and to distinguish whether the right or left limit position is crossed.

- 1 = Limit plate
- 2 = Homing track
- 3 = Reference mark
- 4 = Hole for adhesive

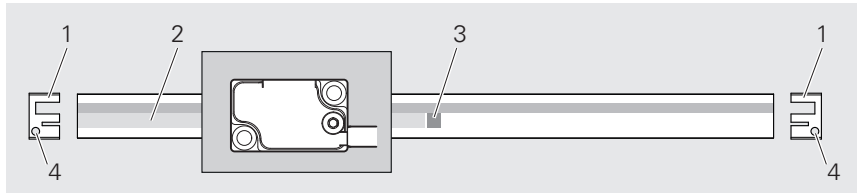

Attaching the limit plates

- ▶ Attach the limit plates to the scale

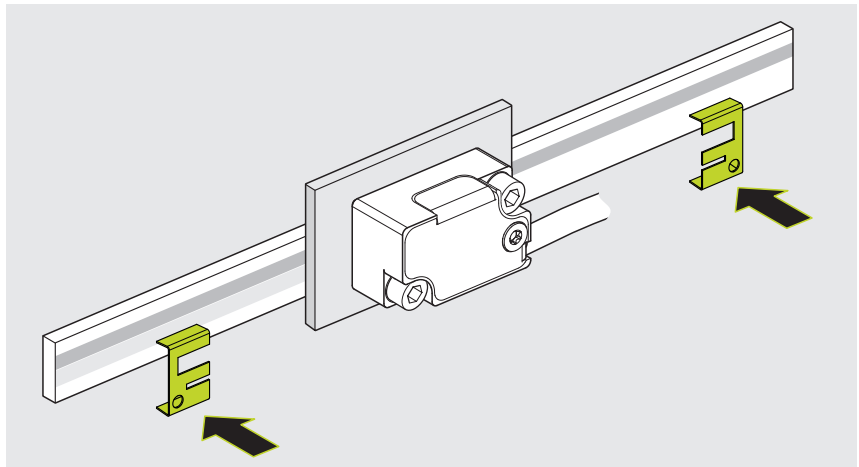

- ▶ Roughly set the desired distance

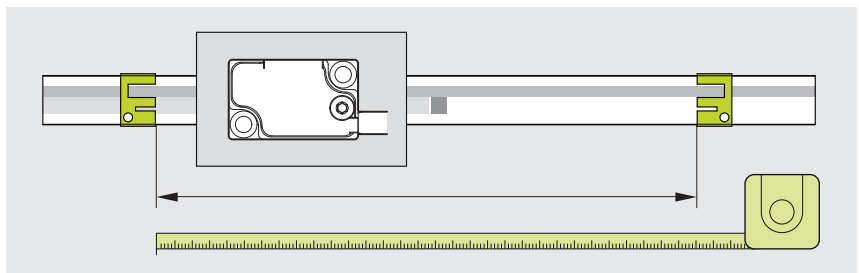

Setting the trigger points

- ▶ Swipe to switch to the **Switching signals** screen
- ▶ Traverse the reference mark with the scanning head

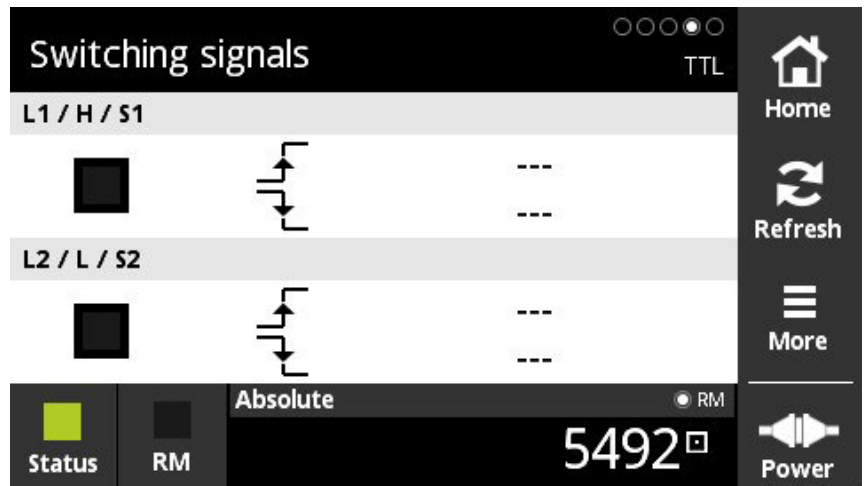

The **Switching signals** screen

- ▶ Move the scanning head over the limit plate until the PWT shows a value at position L1 or L2
(1) = Limit at left, no homing
(2) = Limit at right, homing
- ▶ Slide the limit plate to the desired position
- ▶ Move the scanning head over the limit plate again and check the value
- ▶ Repeat this procedure for the second limit plate

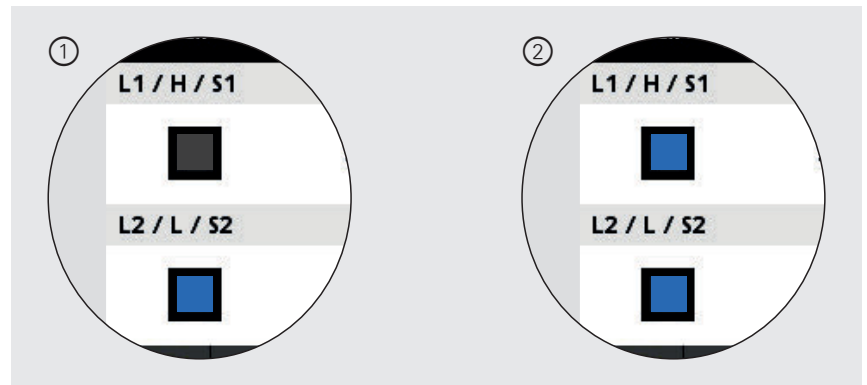

Securing the limit plates

- ▶ Press the limit plates against the scale
- ▶ Insert a small amount of adhesive into the holes for the adhesive
- ▶ Allow the adhesive to harden as appropriate for the intended operating temperature

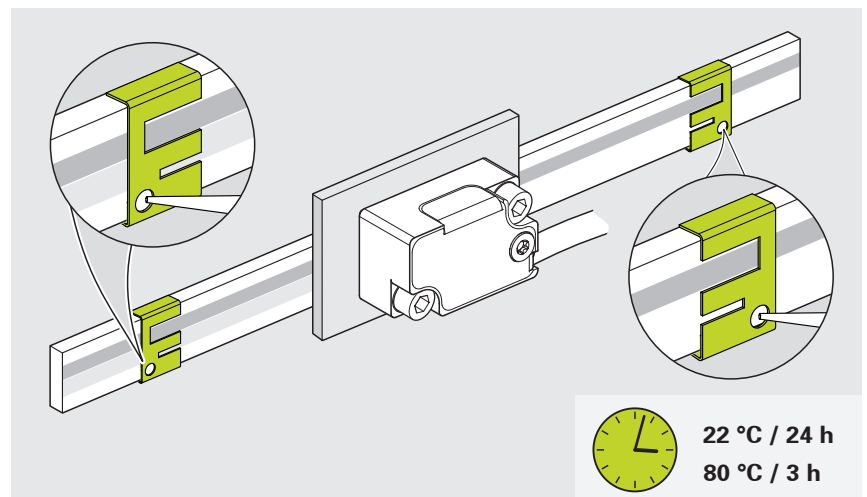

Note the specifications regarding the curing temperature and curing time.

Operating temperature	Curing temperature	Curing time
-10 °C to +30 °C	22 °C	24 hours
-10 °C to +70 °C	80 °C	3 hours

Next step: "Final steps", Page 71

6 Final steps

6.1 Connecting the encoder to the downstream electronics

WARNING

Danger of electric shock due to plug connections under voltage!

Connecting and disconnecting live cables and plug connections in the equipment can result in death or serious injury.

- ▶ Only connect and disconnect cables and plug connections when no current is flowing through them
- ▶ Disconnect the downstream electronics from power before connecting the product
- ▶ For cables without connectors, pay attention to the pin layout

- ▶ Connect the encoder to the downstream electronics

NOTICE

Property damage resulting from incorrect routing of the connecting cable!

Connecting cables may become damaged as a result of incorrect routing.

- ▶ Observe the maximum permissible bend radii
- ▶ Do not cross connecting cables in drag chains
- ▶ Route connecting cables professionally



For more information on the cable characteristics and cable routing, refer to the **Cables and Connectors** brochure.

- ▶ www.heidenhain.com/documentation
- ▶ Enter the document ID **1206103**



For more information on the pin layouts of pre-assembled cables, refer to the **Cables and Connectors** brochure.

- ▶ www.heidenhain.com/documentation
- ▶ Enter the document ID **1206103**



For more information on sources of interference, refer to the **Interfaces of HEIDENHAIN Encoders** brochure.

- ▶ www.heidenhain.com/documentation
- ▶ Enter the document ID **1078628**

7 Removal

This chapter describes the disassembly of the product.

7.1 Safety precautions regarding removal

WARNING

Risk of injury due to plug connections under voltage!

If you disengage plug connections while the equipment is under power, this may result in fatal accidents or severe personal injury.

- ▶ Do not engage or disengage any connecting elements while the product is under power

WARNING

Risk of injury due to moving machine parts!

Depending on the installation location and the application, there is a high risk of injury due to moving machine parts.

- ▶ Observe all of the machine manufacturer's notes on working on the machine (e.g., always disconnect the machine from the power supply)

CAUTION

Fragile carrier material of the scale unit or the scale itself!

Risk of injury from splinters and sharp edges of the carrier material

- ▶ Wear protective gloves and safety goggles
- ▶ Do not bend or deform the scale unit or scale excessively

7.2 Removing the scanning head

- ▶ Disconnect the encoder from the downstream electronics
- ▶ Remove the scanning head in the reversed sequence of mounting

Further information: "Mounting the scanning head", Page 27

7.3 Removing the scale



Further information can be found in the **Disassembly Instructions**.

- ▶ www.heidenhain.com/documentation
- ▶ Enter the document ID **1185755**

HEIDENHAIN

DR. JOHANNES HEIDENHAIN GmbH

Dr.-Johannes-Heidenhain-Straße 5

83301 Traunreut, Germany

☎ +49 8669 31-0

☎ +49 8669 32-5061

info@heidenhain.de

Technical support ☎ +49 8669 32-1000

Measuring systems ☎ +49 8669 31-3104

service.ms-support@heidenhain.de

NC support ☎ +49 8669 31-3101

service.nc-support@heidenhain.de

NC programming ☎ +49 8669 31-3103

service.nc-pgm@heidenhain.de

PLC programming ☎ +49 8669 31-3102

service.plc@heidenhain.de

APP programming ☎ +49 8669 31-3106

service.app@heidenhain.de

www.heidenhain.com