



HEIDENHAIN



Product Information

LIF 471 V

LIF 481 V

LIF 481 U

Exposed Linear Encoder for
High- and Ultrahigh-Vacuum
Applications

LIF 471 V/LIF 481 V/LIF 481 U

Incremental linear encoder for high- and ultrahigh-vacuum applications

- Special, vacuum-compatible version
- For measuring steps of down to 2 nm
- Position detection through homing track and limit switches

Illustration without limit plate and fixed point

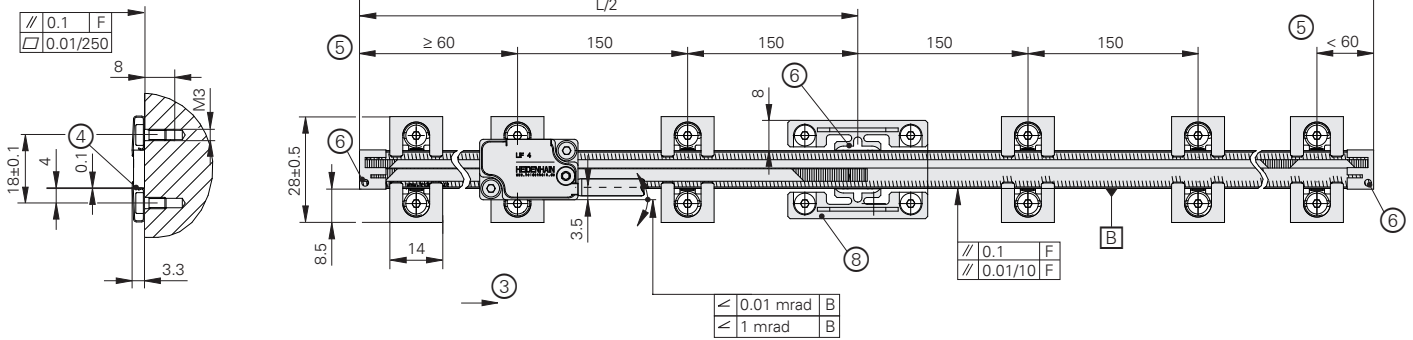
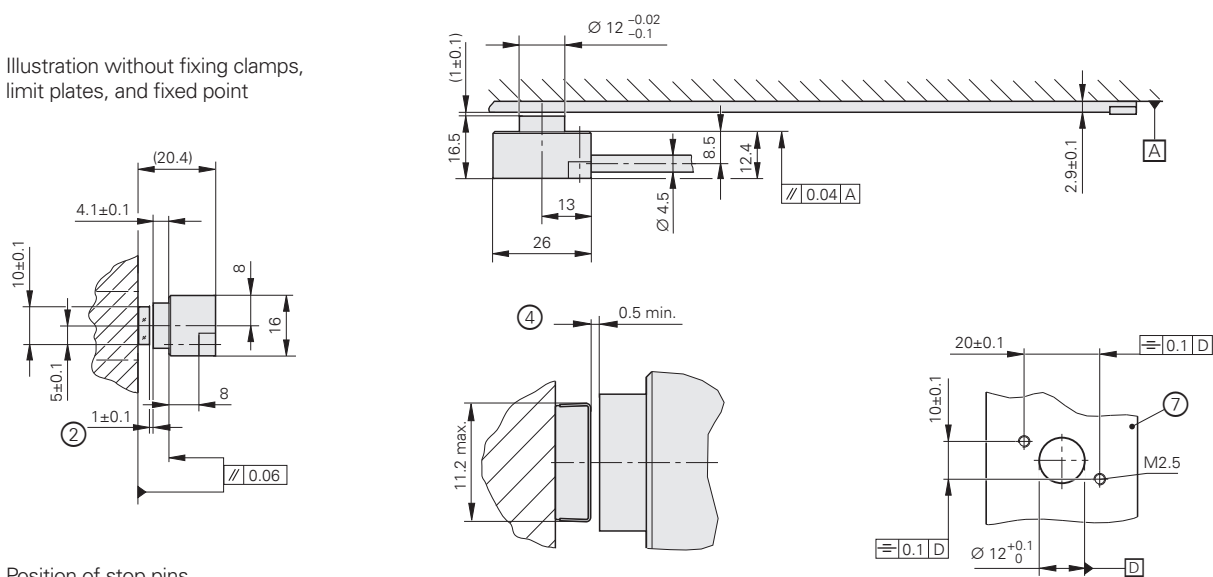
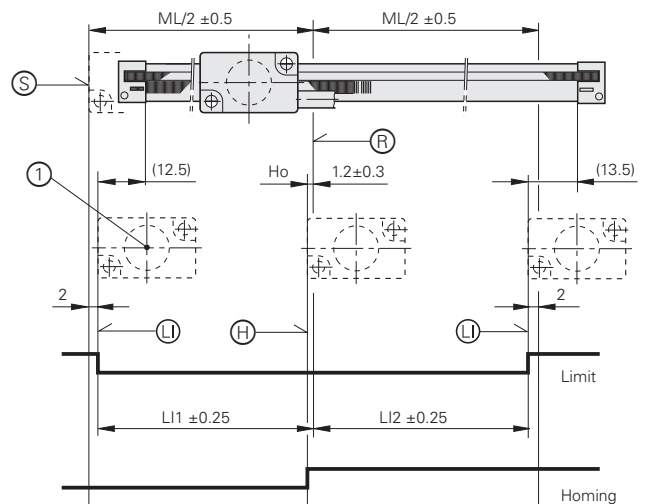
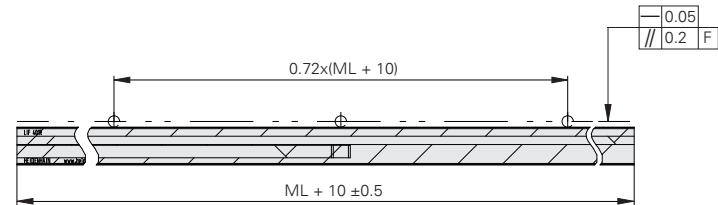

Illustration without fixing clamps, limit plates, and fixed point



Position of stop pins



- L = Scale length
- F = Machine guideway
- * = Maximum change during operation
- ML = Measuring length
- LI = Limit mark, adjustable
- H = Switch for homing track, homing switching edges
- Ho = Trigger point for homing
- R = Position of reference mark
- S = Beginning of measuring length
- 1 = Optical centerline
- 2 = Gap between scanning head / scale
- 3 = Positive direction of measurement
- 4 = Clearance set with spacer shim
- 5 = Additional pair of fixing clamps, depending on ML
- 6 = Vacuum adhesive, dries at room temperature in 24 h
- 7 = Mounting surface for scanning head
- 8 = Fixed-point element



Scale	LIF 401 R													
Measuring standard* Coefficient of linear expansion	SUPRADUR phase grating on Zerodur glass ceramic or glass; grating period: 8 µm $\alpha_{\text{therm}} = (0 \pm 0.1) \cdot 10^{-6} \text{ K}^{-1}$ (Zerodur glass-ceramic); $\alpha_{\text{therm}} \approx 8 \cdot 10^{-6} \text{ K}^{-1}$ (glass)													
Accuracy grade	±3 µm													
Baseline error	≤ ±0.225 µm/5 mm													
Measuring length (ML)* in mm	70	120	170	220	270	320	370	420	470	520	570	620	670	
Reference marks	720	770	820	870	920	970	1020	1140	1240	1340	1440	1540	1640	
Mass	0.8 g + 0.08 g/mm of measuring length													

Scanning head	LIF 48 V/LIF 48 U		LIF 47 V				
Interface	~ 1 V _{PP}		□TTL				
Integrated interpolation* Signal period	– 4 µm		5-fold 0.8 µm	10-fold 0.4 µm	20-fold 0.2 µm	50-fold 0.08 µm	100-fold 0.04 µm
Cutoff frequency –3 dB	≥ 1 MHz		–				
Scanning frequency*	–		≤ 500 kHz ≤ 250 kHz ≤ 125 kHz	≤ 250 kHz ≤ 125 kHz ≤ 62.5 kHz	≤ 250 kHz ≤ 125 kHz ≤ 62.5 kHz	≤ 100 kHz ≤ 50 kHz ≤ 25 kHz	≤ 50 kHz ≤ 25 kHz ≤ 12.5 kHz
Edge separation <i>a</i>	–		≥ 0.080 µs ≥ 0.175 µs ≥ 0.370 µs	≥ 0.080 µs ≥ 0.175 µs ≥ 0.370 µs	≥ 0.040 µs ≥ 0.080 µs ≥ 0.175 µs	≥ 0.040 µs ≥ 0.080 µs ≥ 0.175 µs	≥ 0.040 µs ≥ 0.080 µs ≥ 0.175 µs
Traversing speed ¹⁾	≤ 240 m/min		≤ 120 m/min ≤ 60 m/min ≤ 30 m/min	≤ 60 m/min ≤ 30 m/min ≤ 15 m/min	≤ 60 m/min ≤ 30 m/min ≤ 15 m/min	≤ 24 m/min ≤ 12 m/min ≤ 6 m/min	≤ 12 m/min ≤ 6 m/min ≤ 3 m/min
Interpolation error RMS position noise	±12 nm 0.6 nm (1 MHz ²⁾)		–				
Electrical connection*	<ul style="list-style-type: none"> <i>Interface electronics outside of vacuum:</i> Cable (0.5 m, 1 m, 2 m or 2.5 m) up to vacuum feed-through; cable (0.5 m) up to 15-pin D-sub connector with built-in interface electronics <i>Interface electronics inside of high vacuum:</i> Cable (0.5 m, 1 m, 2 m or 3 m) with 15-pin D-sub connector with built-in interface electronics 						
Cable length	See interface description; however: <i>Incremental:</i> ≤ 30 m; <i>Homing, Limit:</i> ≤ 10 m (with HEIDENHAIN cable)						
Supply voltage	DC 5 V ±0.25 V						
Current consumption	< 150 mA		< 165 mA (without load)				
Vibration 55 Hz to 2000 Hz Shock 11 ms	≤ 400 m/s ² (EN 60068-2-6) ≤ 500 m/s ² (EN 60068-2-27)						
Operating temperature	0 °C to 50 °C						
Bake-out temperature	100 °C (LIF 4x V); 120 °C (LIF 48 U)						
PCB material	FR4						
Mass	Scanning head	9 g					
	Cable	38 g/m					
	Connector	75 g					

* Please select when ordering

¹⁾ With TTL: maximum traversing speed during referencing: 9.6 m/min (40 kHz)

²⁾ –3 dB cutoff frequency of subsequent electronics

Encoders for use in a vacuum

These vacuum-compatible encoders feature the following characteristics:

- Air vents
- Specialized cleaning and packaging
- Cable with PTFE insulation and tin-plated copper braiding

Residual gas analysis of HEIDENHAIN vacuum components

The influence of vacuum components on the quality of a vacuum can be determined through residual gas analyses. In these analyses, a sample in a vacuum chamber is pumped out to at least 10^{-6} mbar (turbomolecular pump, pumping speed 15 l/s to 200 l/s). The residual gases are measured with a mass spectrometer (Pfeiffer QMA 200) and an absolute pressure sensor (VACOM ATMION). The outgoing behavior of the examined sample can then be deduced by subtracting the typical residual gases of the empty chamber. The amount of remaining residual gases depends not only on the cleanliness of the sample and the tested materials, but also on the pump type used and its pumping speed. The higher the pumping speed for the measurement is, and the longer the gas is pumped out, the lower the amount of residual gases will be.

To attain the lowest possible outgassing values, HEIDENHAIN recommends baking at 100 °C for 48 hours under high vacuum conditions.

Residual gas analysis

The spectrum shown is the typical result for an LIF 48V, LIF 47V or LIF 48U scanning head with a one-meter cable and APE interface unit (connector) after having been baked in a high vacuum for 24 hours at 100 °C.

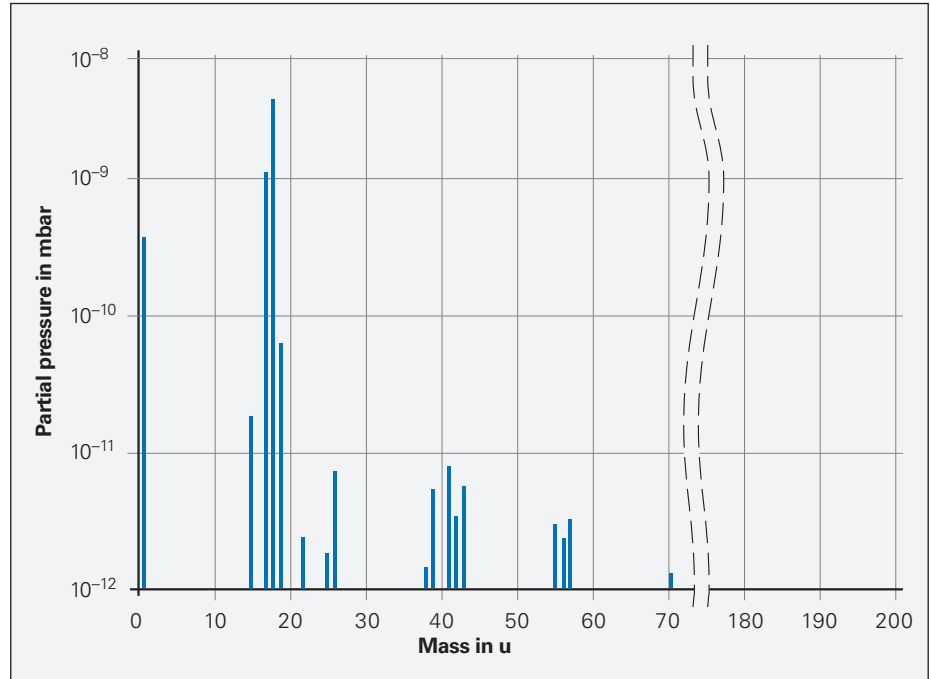

The spectrum was determined with three scanning heads at an absolute pressure of 1.5^{-7} mbar and a pumping speed of 92 l/s.

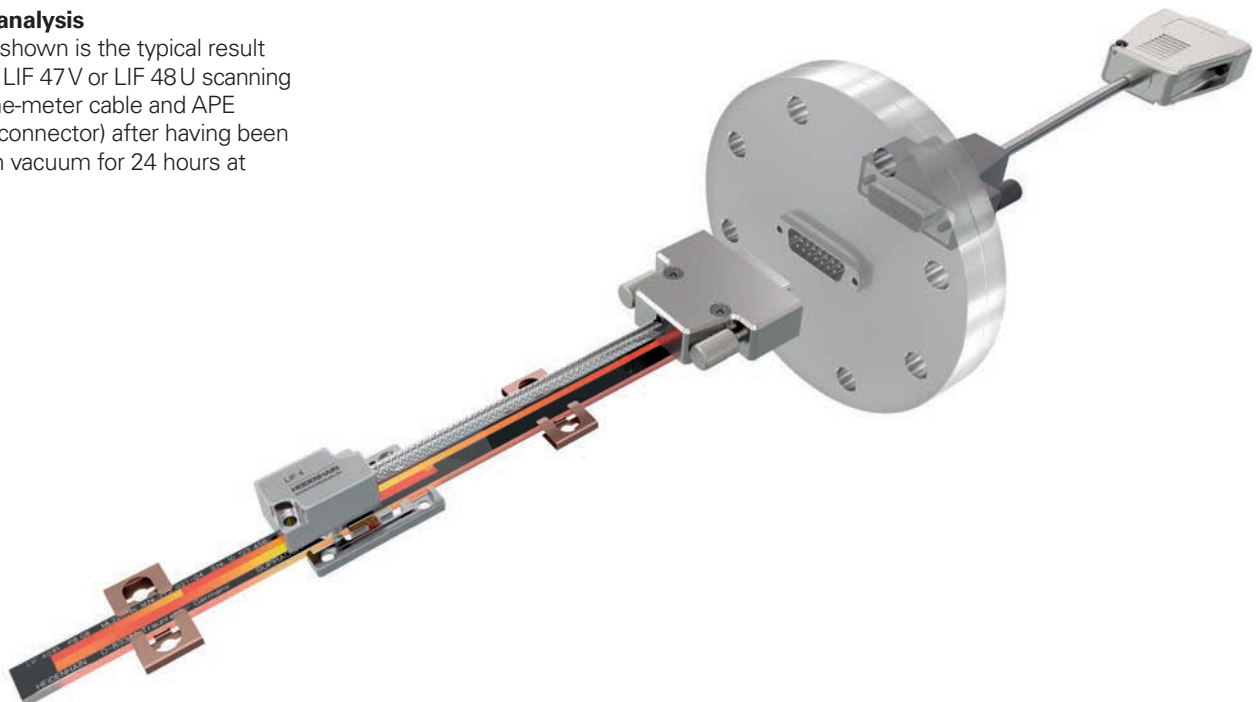

LIF 481 U variant

Electrical connection

High vacuum

The LIF 471 V/LIF 481 V is available with two different cable versions:

Interface electronics inside of high vacuum:

The scanning head cable has a 15-pin D-sub connector that contains the interface electronics. A vacuum feed-through (15-pin D-sub on DN63CF flange) and an extension cable are available as accessories.

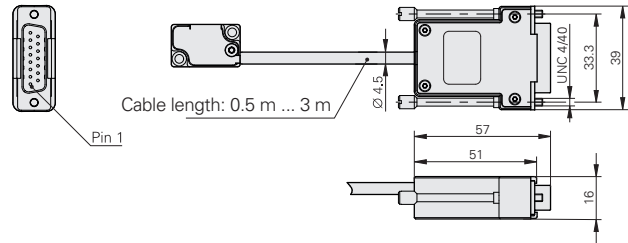

Interface electronics outside of high vacuum:

The scanning head cable has a high-vacuum-compatible round connector. Included with the encoder are the corresponding high-vacuum feed-through and the adapter cable with a 15-pin D-sub connector with integrated interface electronics.

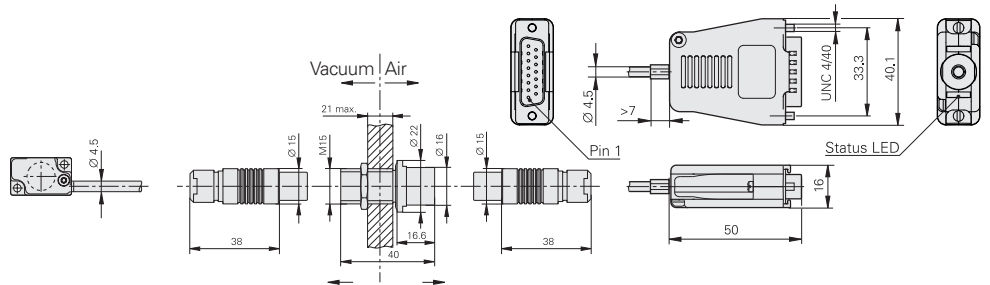

Ultrahigh vacuum

The LIF 481 U is available with the following cable feed-through:

When used in an ultrahigh vacuum, the encoder must not contain any electronic components such as signal converters. The LIF 481 U is equipped with a cable and an ultrahigh-vacuum-compatible D-sub connector. Included in delivery is an adapter cable with a signal converter integrated into the D-sub connector. A vacuum feed-through (15-pin D-sub connector on DN63CF flange) and an extension cable are available as accessories.

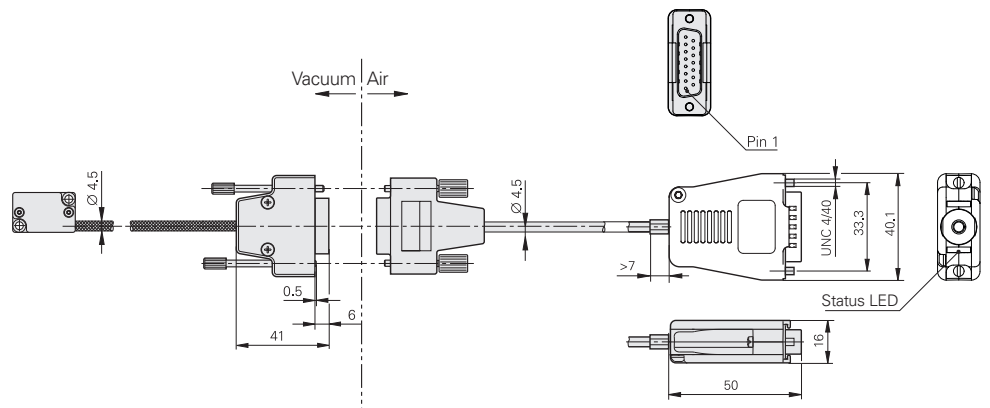

The built-in signal-quality indicator permits both a reliable assessment of the incremental signals and inspection of the reference-mark signal. The quality of the **incremental signals** is indicated by a range of colors, permitting quite detailed signal-quality differentiation. The tolerance conformity of the **reference-mark signal** is shown by means of a pass/fail indicator.

LED indicator for incremental signals

LED color	Quality of the scanning signals
●	Optimal
●	Good
●	Acceptable
●	Unsatisfactory



Signal-quality indicator in the signal converter (for variants in air)

LED indicator for reference-mark signal (operating check)

When the reference mark is traversed, the LED briefly lights up in red or blue:

- Out of tolerance
- Within tolerance

Pin layout

15-pin D-sub connector

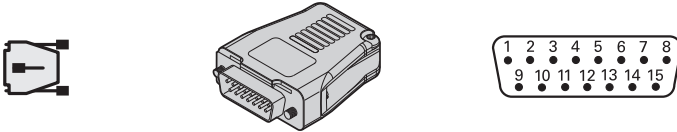

	Power supply				Incremental signals						Other signals				
	4	12	2	10	1	9	3	11	14	7	13	8	6	15	5
\square TTL	U_p	Sensor 5V	0V	Sensor 0V	U_{a1}	\overline{U}_{a1}	U_{a2}	\overline{U}_{a2}	U_{a0}	\overline{U}_{a0}	\overline{U}_{aS}	H	L	PWT ¹⁾	Vacant
\sim 1V _{PP}	● — ●		● — ●		A+	A-	B+	B-	R+	R-	As-signed			As-signed	Vacant
	Brown/ Green	Blue	White/ Green	White	Brown	Green	Gray	Pink	Red	Black	Violet	Green/ Black	Yellow/ Black	Yellow	/

Shield on housing; **U_p** = Power supply voltage

Sensor: The sense line is connected in the encoder with the corresponding power supply line.

Vacant pins or wires must not be used.

¹⁾ TTL/11 μA_{PP} conversion for the PWT

HEIDENHAIN

DR. JOHANNES HEIDENHAIN GmbH
Dr.-Johannes-Heidenhain-Straße 5
83301 Traunreut, Germany

☎ +49 8669 31-0
FAX +49 8669 32-5061
info@heidenhain.de

www.heidenhain.com

This Product Information document supersedes all previous editions, which thereby become invalid. The basis for ordering from HEIDENHAIN is always the Product Information document edition valid when the order is placed.



Further information:

Comply with the requirements described in the following documents to ensure correct and intended operation:

- Brochure: *Exposed Linear Encoders* ID 208960-xx
- Technical Information: *Linear Encoders for Vacuum Technology* ID 627568-xx