

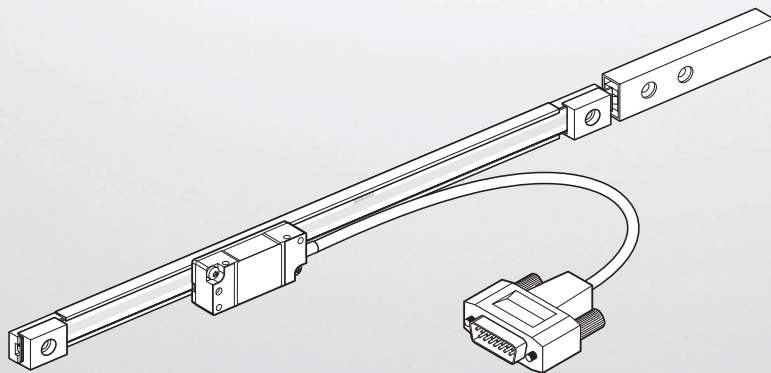

HEIDENHAIN



LIDA 475

LIDA 485

Mounting Instructions

English (en)
06/2025

Table of contents

1	Basic information.....	4
1.1	Validity of the documentation.....	4
1.2	Target groups of the Mounting Instructions.....	4
1.3	Notes on reading the documentation.....	5
1.4	Symbols and fonts used for marking text.....	6
1.5	Notes in this documentation.....	7
1.6	Units and tolerances.....	7
2	Safety.....	8
2.1	Personnel qualification.....	8
2.2	General safety precautions.....	8
3	Items supplied and accessories.....	10
3.1	Items supplied.....	10
3.1.1	Items supplied with the parts kit.....	10
3.1.2	Items supplied with the scale-tape carrier section.....	11
3.1.3	Items supplied with the scanning head.....	12
3.2	Mounting accessories.....	13
3.2.1	Accessories for mounting the scale-tape carrier sections.....	13
3.2.2	Accessories for mounting the scanning head.....	13
3.2.3	Accessories for activating the limit switches.....	14
4	Mounting.....	15
4.1	Requirements and notes.....	15
4.2	Mounting the parts kit.....	16
4.2.1	Choosing the mounting variant.....	16
4.2.2	Variant: Mounting with adhesive film.....	17
4.2.3	Variant: Mounting with screws.....	23
4.3	Mounting the scanning head.....	28
4.3.1	Choosing the mounting variant.....	28
4.3.2	Variant: Mounting with the holder on the side.....	29

4.3.3	Variant: Mounting with the holder at top.....	31
4.3.4	Variant: Mounting with the holder at bottom.....	33
5	Adjustment and diagnosis.....	35
5.1	Requirements and notes.....	35
5.2	Continuity check.....	35
5.2.1	Materials and tools.....	35
5.2.2	Measuring the electrical resistance.....	35
5.3	Selecting the scanning head.....	36
5.4	Adjustment and diagnosis of LIDA 47.....	37
5.4.1	Connecting the encoder to the PWT.....	37
5.4.2	Adjusting the scanning head.....	41
5.4.3	Checking the function indicator.....	44
5.4.4	Tensioning the scale tape.....	45
5.4.5	Activating the limit switches.....	51
5.5	Adjustment and diagnosis of LIDA 48.....	53
5.5.1	Connecting the encoder to the PWT.....	53
5.5.2	Adjusting the scanning head.....	57
5.5.3	Checking the function indicator.....	59
5.5.4	Tensioning the scale tape.....	60
5.5.5	Activating the limit switches.....	65
6	Final steps.....	67
6.1	Connecting the encoder to the downstream electronics.....	67
7	Removal.....	68
7.1	Safety precautions regarding removal.....	68
7.2	Removing the scanning head.....	68
7.3	Disassembling the parts kit.....	68

1 Basic information

This chapter contains information about the product and the Mounting Instructions.

1.1 Validity of the documentation

These Mounting Instructions apply to LIDA 475, LIDA 485.

- Before using the documentation, check whether the documentation and product model match. The designation of the product is printed on the ID label.

ID label

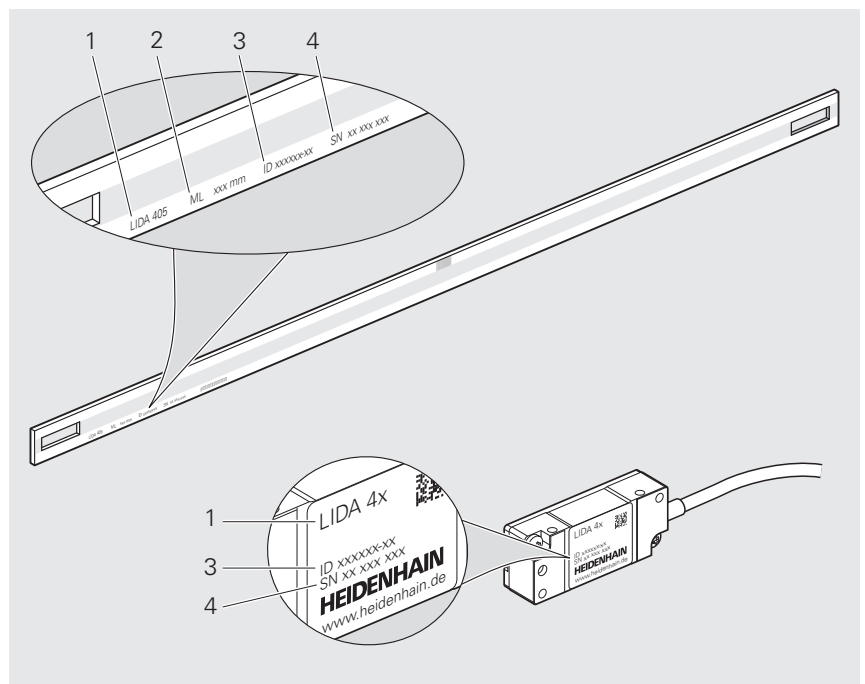

ID label with legend

- 1 Product name
- 2 Measuring length (ML)
- 3 Product ID / Part number (ID)
- 4 Serial number (SN)

1.2 Target groups of the Mounting Instructions

The Mounting Instructions must be read and observed by every person who performs any of the following tasks:

- Design
- Mounting
- Removal

1.3 Notes on reading the documentation

WARNING

Fatal accidents, personal injury or property damage caused by non-compliance with the documentation!

Failure to comply with the documentation may result in fatal accidents, personal injury or property damage.

- ▶ Read the documentation carefully from beginning to end
- ▶ Keep the documentation for future reference

The following table lists the various parts of the documentation in their order of reading priority.

Document type	Description
Addendum	An Addendum supplements or supersedes the corresponding contents of the Operating Instructions and, if applicable, of the Mounting Instructions. If an Addendum is included in the shipment, it has the highest priority for reading. All other documentation content retains its validity.
Operating Instructions	The Operating Instructions contain all of the information and safety instructions for the proper and intended operation of the device. The Operating Instructions (English language version) are included in delivery and can also be downloaded in other languages from www.heidenhain.com/documentation . The Operating Instructions must be read prior to initial operation of the product. The Operating Instructions have the second highest priority for reading.
Mounting Instructions	The Mounting Instructions contain all the information and safety precautions needed for the proper mounting and installation of a product. The Mounting Instructions are not included in delivery and must be downloaded from www.heidenhain.com/documentation . The Mounting Instructions have the third highest priority for reading.

Would you like any changes, or have you found any errors?

We are continuously striving to improve our documentation for you. Please help us by sending your suggestions to the following e-mail address:

userdoc@heidenhain.de

1.4 Symbols and fonts used for marking text

In these instructions the following symbols and fonts are used for marking text:

Format	Meaning
▶ ...	Identifies an action and the result of this action
> ...	Example: <ul style="list-style-type: none"> ▶ Tilt the shipping brace to remove it (c) > The shipping brace has been removed now
■ ...	Identifies an item of a list
■ ...	Example: <ul style="list-style-type: none"> ■ Solid contaminants: class 3 ■ Max. pressure dew point: class 4

1.5 Notes in this documentation

Safety precautions

Precautionary statements warn of hazards in handling the product and provide information on their prevention. Precautionary statements are classified by hazard severity and divided into the following groups:

⚠ DANGER
Danger indicates hazards for persons. If you do not follow the avoidance instructions, the hazard will result in death or severe injury .

⚠ WARNING
Warning indicates hazards for persons. If you do not follow the avoidance instructions, the hazard could result in death or serious injury .

⚠ CAUTION
Caution indicates hazards for persons. If you do not follow the avoidance instructions, the hazard could result in minor or moderate injury .

NOTICE
Notice indicates danger to material or data. If you do not follow the avoidance instructions, the hazard could result in property damage .

Informational notes

Informational notes ensure reliable and efficient operation of the product. Informational notes are divided into the following groups:

	The information symbol indicates a tip . A tip provides important additional or supplementary information.
---	--

	The book symbol indicates a cross reference . A cross reference leads to external documentation, for example: further documentation from HEIDENHAIN or another supplier.
---	--

	The globe symbol represents a cross reference to a source on the Internet, e.g. www.heidenhain.de .
---	---

1.6 Units and tolerances

Unless otherwise specified, the dimensions stated in these Mounting Instructions are given in millimeters.

Unless otherwise specified, the tolerances stated in these Mounting Instructions conform to ISO 8015 and ISO 2768 standards.

mm 
 Tolerancing ISO 8015
 ISO 2768:1989-mH
 ≤ 6 mm: ±0.2 mm

2 Safety

This chapter provides important safety information needed for the proper mounting and installation of the product.

2.1 Personnel qualification

Mounting, initial configuration and removal must be conducted by a qualified specialist under compliance with local safety regulations.

2.2 General safety precautions

WARNING

Danger of electric shock due to connection to unsuitable downstream electronics!

If you connect unsuitable downstream electronics to the product, fatal accidents or severe personal injuries can occur.

- ▶ Connect the product only to downstream electronics whose supply voltage comes from PELV systems

WARNING

Live plug connections!

If you disengage plug connections while the equipment is under power, this may result in fatal accidents or severe personal injury.

- ▶ Do not engage or disengage any connecting elements while the product is under power

WARNING

Risk of injury from damaged or worn components!

Safety functions can fail if damaged or worn components are installed unintentionally. Failed safety functions can result in death or serious injury.

- ▶ Inspect the component for damage
- ▶ Do not use any damaged or worn components
- ▶ In case of replacement, repair the thread
- ▶ Use new screws, spring pins and nuts
- ▶ Secure screws and nuts with suitable material-bonding anti-rotation lock

NOTICE

Property damage due to mechanical stress!

- ▶ Do not drop the product or subject it to major vibration
- ▶ Do not expose the product to mechanical stress
- ▶ Do not change the physical structure of the product

NOTICE**Property damage due to electrical stress!**

- ▶ Do not engage or disengage any connecting elements while the product is under power
- ▶ Do not touch the contacts of the plug connections

NOTICE**Electrostatic discharge (ESD)!**

This product contains electrostatically sensitive components that can be destroyed by electrostatic discharge (ESD).





- ▶ It is essential to observe the safety precautions for handling ESD-sensitive components
- ▶ Never touch connector pins without ensuring proper grounding
- ▶ Wear a grounded ESD wristband when handling the connections of the product

3 Items supplied and accessories

This chapter contains information on the items supplied and the available accessories of the product.

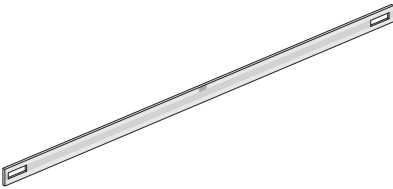
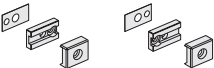
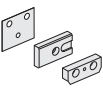
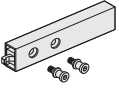
3.1 Items supplied

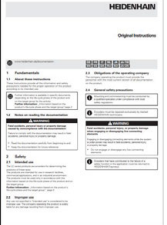
3.1.1 Items supplied with the parts kit

Component	Figure
Scale tape	
Shims, spacers, and mounting blocks	
Shim (U), holder and fixing clamp (Z) *	
Tensioning device with screws	
Magnet, north pole	
Magnet, south pole	
Operating Instructions	
Quality Inspection Document	

* The number of required components depends on the measuring length (ML).

3.1.2 Items supplied with the scale-tape carrier section

Component	Figure
Scale-tape carrier section (T) * for mounting with adhesive film or for mounting with screws	

* The number of required components depends on the measuring length (**ML**).

Number of components required for mounting with adhesive film

ML	T1970 / U / Z
≤ 3040	0 x
≤ 5040	1 x
≤ 7040	2 x
≤ 9040	3 x
≤ 11 040	4 x
.	.
.	.
≤ 30 040	14 x

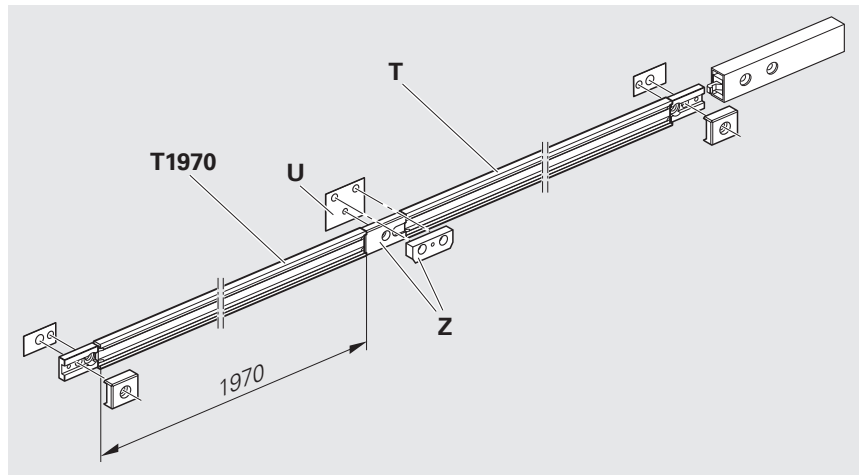

T1970 = Scale-tape carrier section with a length of 1970 mm
T = Remaining length of scale-tape carrier section
U = Shim for holder
Z = Holder with fixing clamp

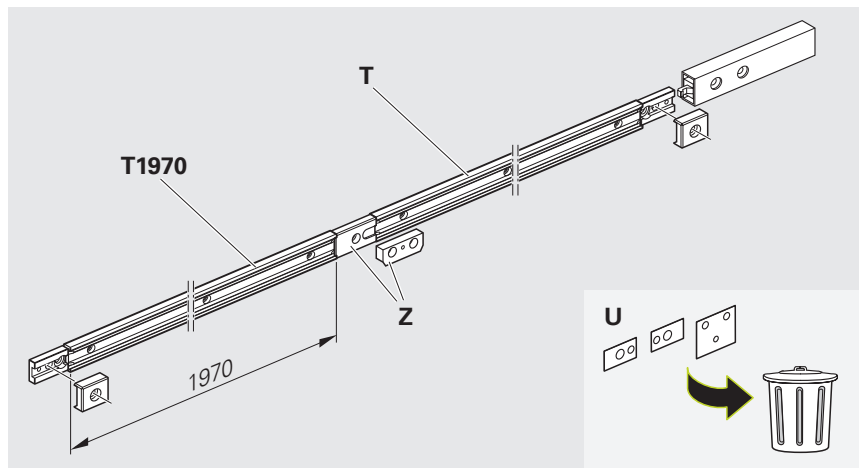

Number of components required for mounting with screws

ML	T1970 / Z
≤ 3040	0 x
≤ 5040	1 x
≤ 7040	2 x
≤ 9040	3 x
≤ 11 040	4 x
.	.
.	.
≤ 30 040	14 x

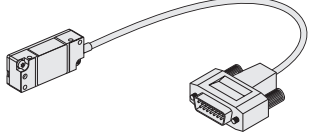
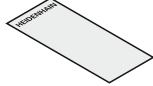
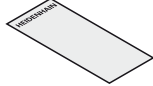
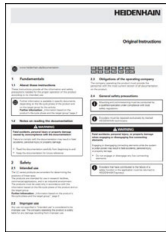

T1970 = Scale-tape carrier section with a length of 1970 mm
T = Remaining length of scale-tape carrier section
Z = Holder with fixing clamp
U = Shims for holders and spacers

3.1.3 Items supplied with the scanning head

Component	Figure
Scanning head	
Spacer shim, 0.15 mm	
Spacer shim, 0.75 mm (not needed)	
Operating Instructions	
Manufacturer's Inspection Document	

3.2 Mounting accessories

The following accessories can be ordered separately from HEIDENHAIN.



For more information on the listed products, please refer to the applicable Mounting Instructions and the **Exposed Linear Encoders** brochure.

- ▶ www.heidenhain.com/documentation
- ▶ Enter the document ID **208960**

3.2.1 Accessories for mounting the scale-tape carrier sections

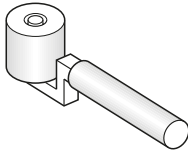
Designation	ID	Figure
Roller	276885-01	

3.2.2 Accessories for mounting the scanning head

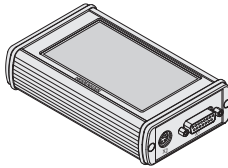
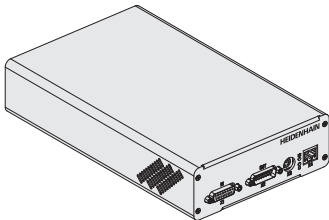
Designation	ID	Figure
PWT 101 testing device	1261013-01	
or		
PWM 21 inspection device	1200635-51	

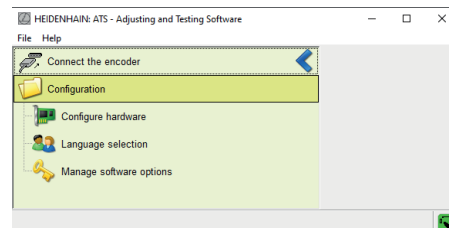

Adjusting and Testing Software (ATS)



The ATS is available for download free of charge.

- ▶ www.heidenhain.com/service/downloads/software/
- ▶ Open the **Categories** selection menu
- ▶ Select the **Inspection and testing devices** category

3.2.3 Accessories for activating the limit switches

Designation	ID	Figure
Magnet, north pole	362581-02	
Magnet, south pole	362582-02	

4 Mounting

This chapter describes the mounting requirements, different mounting variants, and all other tasks necessary when mounting.

4.1 Requirements and notes

NOTICE

Property damage due to inappropriate tools!

Using inappropriate tools for mounting or removal of the encoder may cause damage to the encoder.

- ▶ Do not use hammers
- ▶ Do not use pointed or sharp-edged tools

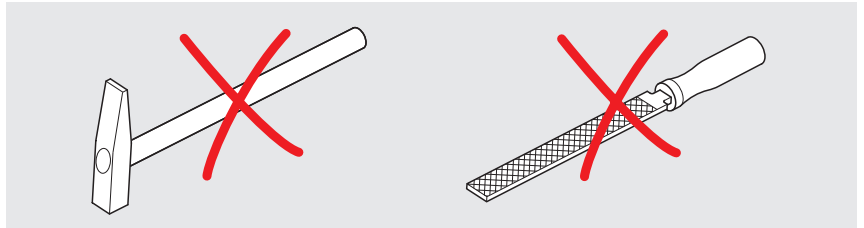

Choose a mounting attitude such that the traverse range is within the measuring length (ML) of the encoder.

(S) = Beginning of measuring length (ML)

Protect the graduation from direct contamination.

In order to ensure correct operation of the encoder, the scale or scale tape must be positioned correctly relative to the scanning head.

Reference mark at top if cable outlet is to the right.

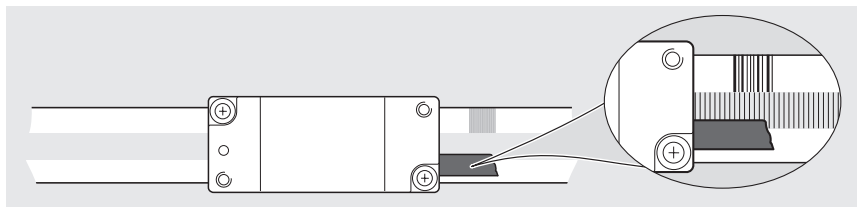
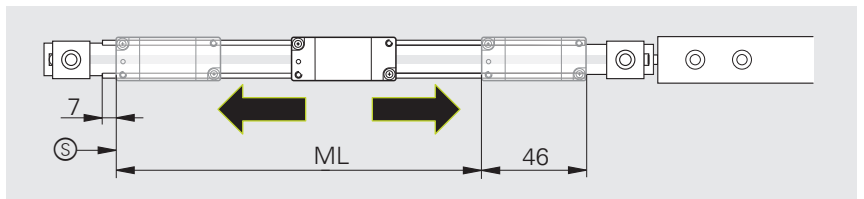

In order to avoid signal interferences, observe the minimum clearance from sources of interference (e.g., power lines).



For more information on sources of interference, refer to the **Interfaces of HEIDENHAIN Encoders** brochure.

- ▶ www.heidenhain.com/documentation
- ▶ Enter the document ID **1078628**



For more information on mounting, refer to the **Mating Dimensions** document.

- ▶ www.heidenhain.com/documentation
- ▶ Enter the product ID
- ▶ Open **Mating Dimensions**

4.2 Mounting the parts kit

4.2.1 Choosing the mounting variant

Mounting variants for the parts kit

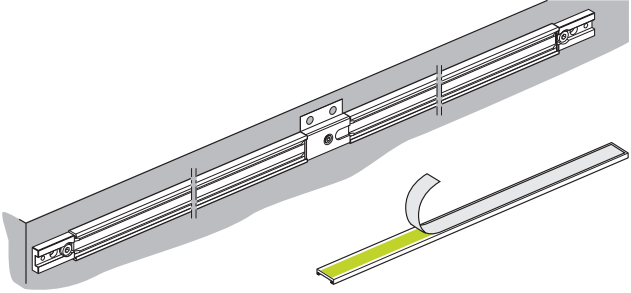
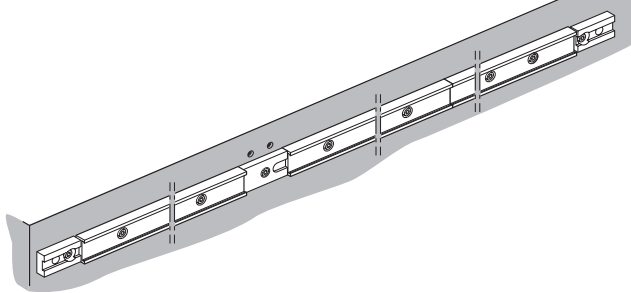
Mounting with adhesive film	Mounting with screws
 <p data-bbox="113 904 212 931">Page 17</p>	 <p data-bbox="799 904 898 931">Page 23</p>

4.2.2 Variant: Mounting with adhesive film

The mounting variant described in this chapter refers to mounting of the parts kit with an adhesive film.

An overview of the mounting variants is provided on Page 16.

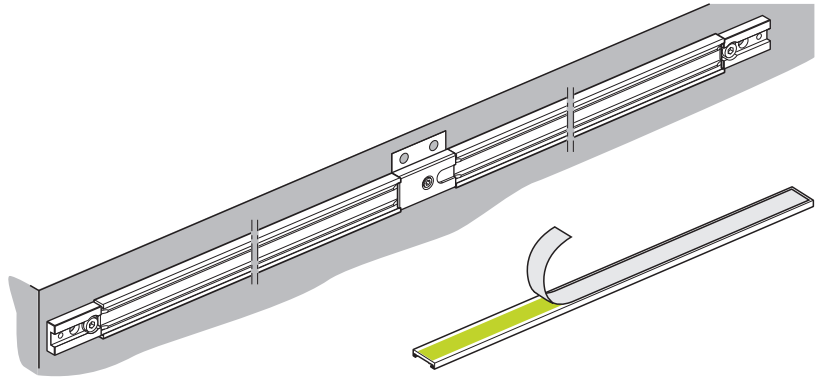

Notes on mounting with adhesive film

The number of required components depends on the measuring length (ML).

ML	T1970 / U / Z
≤ 3040	0 x
≤ 5040	1 x
≤ 7040	2 x
≤ 9040	3 x
≤ 11 040	4 x
≤ 13 040	5 x
.	.
.	.
≤ 30 040	14 x

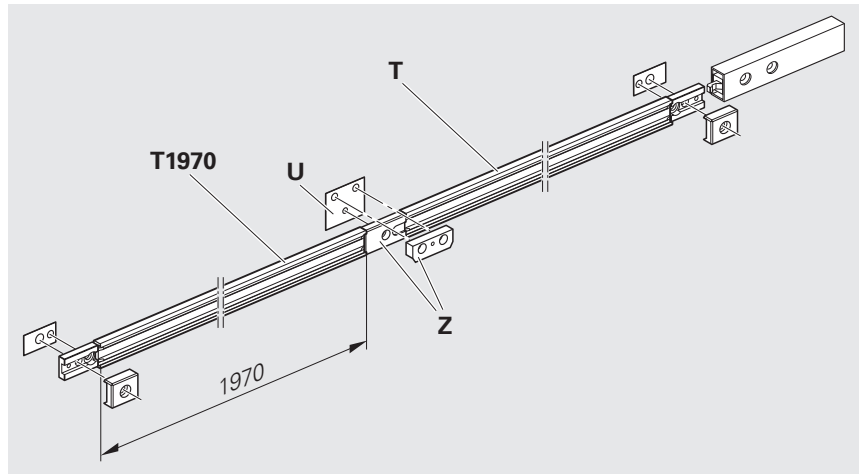

T1970 = Scale-tape carrier section with a length of 1970 mm

T = Remaining length of scale-tape carrier section

U = Shim for holder

Z = Holder with fixing clamp

Note that the mounting surface, as well as the surface of the scale, must be clean and free of paint, dust or grease.

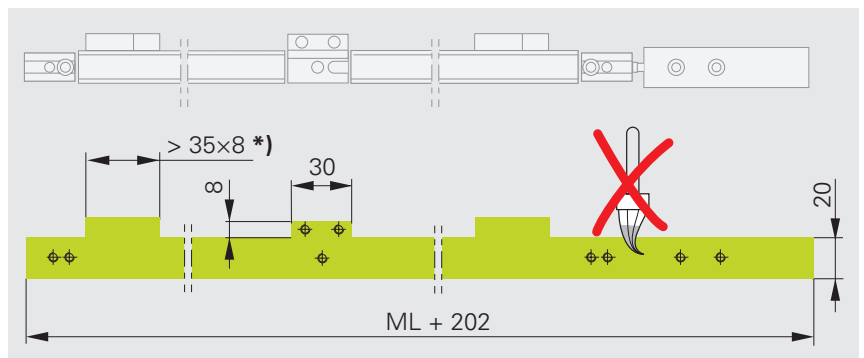

*) Mounting surface of the magnets for activating the limit switches

i You can mount the scale tape carriers by means of stop pins or an aligning rail.

The mounting tolerances refer to the machine guideway **(F)**.

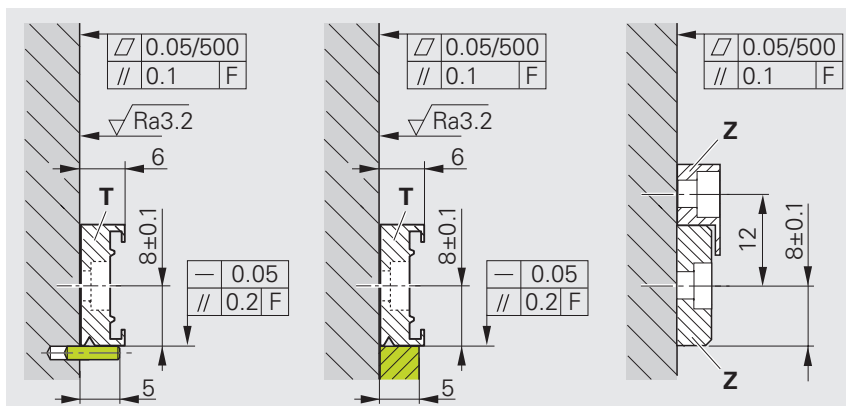

T = Scale-tape carrier section

Z = Holder with fixing clamp

Comply with the specified dimensions to account for thermal expansion.

ML ≤ 2040

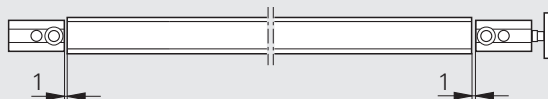

ML > 2040 – ≤ 3040

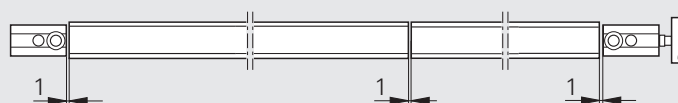

ML > 3040

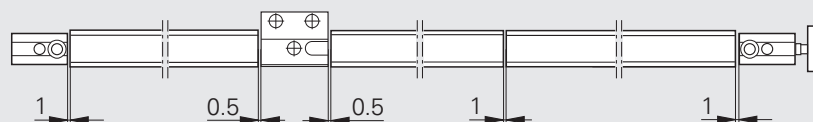

Materials and tools

For this task, the following materials and tools are needed:

Included in delivery

- Scale-tape carrier sections
- Shim, holder, fixing clamp as needed
- Shims, spacers, and mounting blocks
- Tensioning device with screws

To be provided separately

- Stop pins
- Screws (DIN 4762 – M3×6)
- Screws (DIN 7984 – M4×8)
- Torque wrench (hexagon socket for 2.5 mm)
- Torque wrench (hexagon socket for 3.5 mm)
- Roller

Bonding the scale tape carrier

- ▶ Insert the stop pins

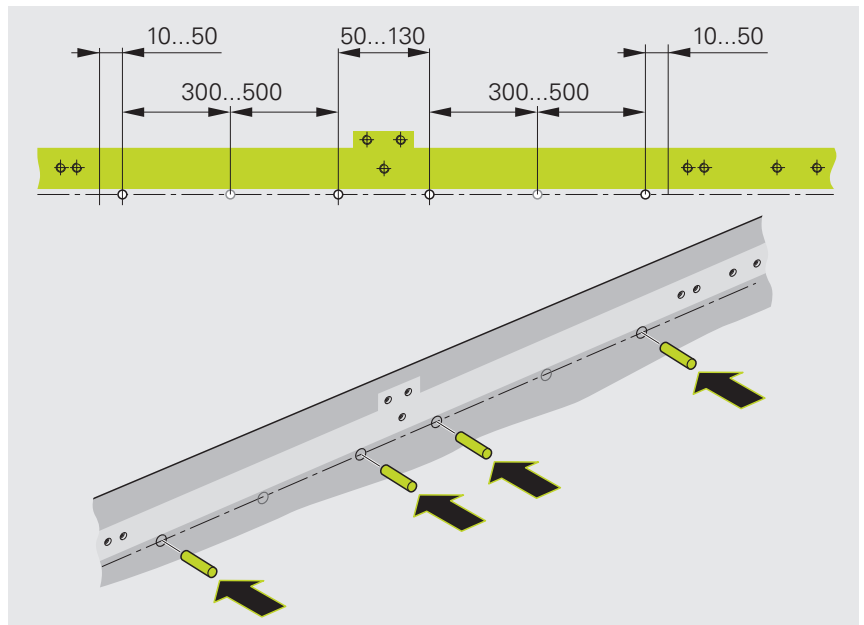

Attach the scale tape carriers with adhesive mounting film only at a temperature of $> 15\text{ }^{\circ}\text{C}$.

Pay attention to the expiration date on the package.

- ▶ Remove the protective foil from the adhesive film

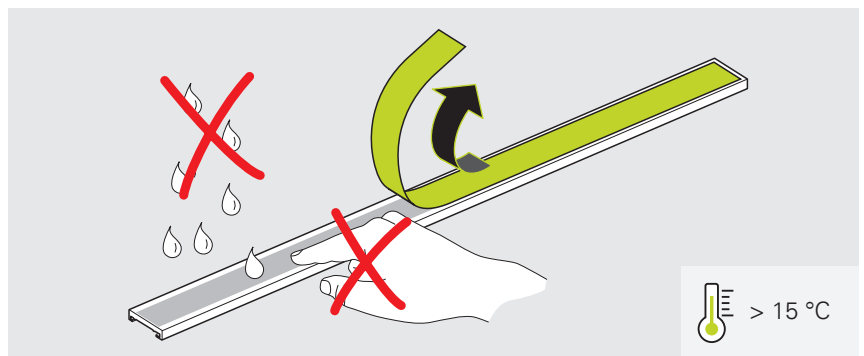

Ensure that the scale tape carriers are positioned correctly.

Use the shim (**U**) to compensate for the thickness of the adhesive mounting film.

- ▶ Carefully place the scale tape carriers onto the stop pins
- ▶ Push the scale tape carrier against the mounting surface and lightly press them against the mounting surface

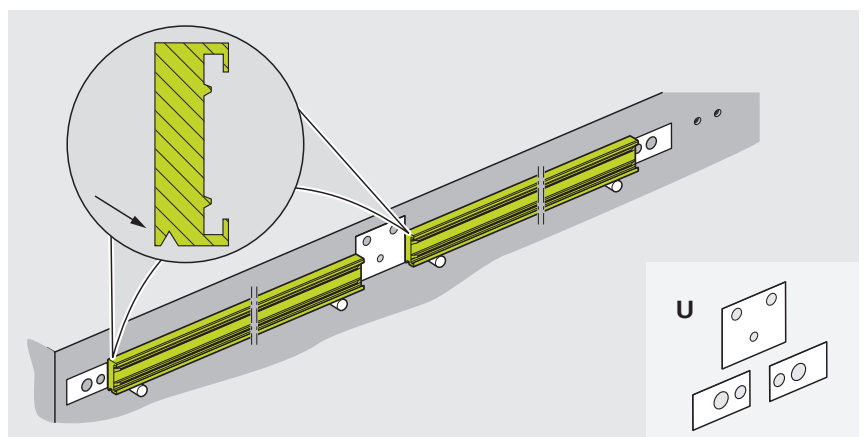

- ▶ If holders are required, fasten them with the specified torque
- ▶ Fasten the spacers with the specified torque

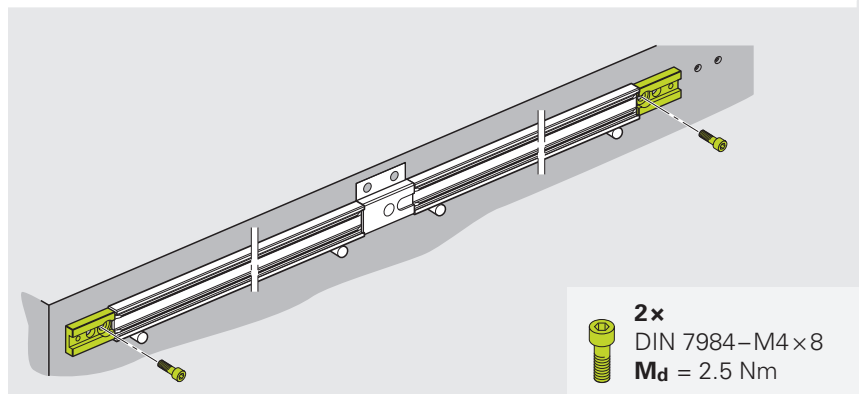
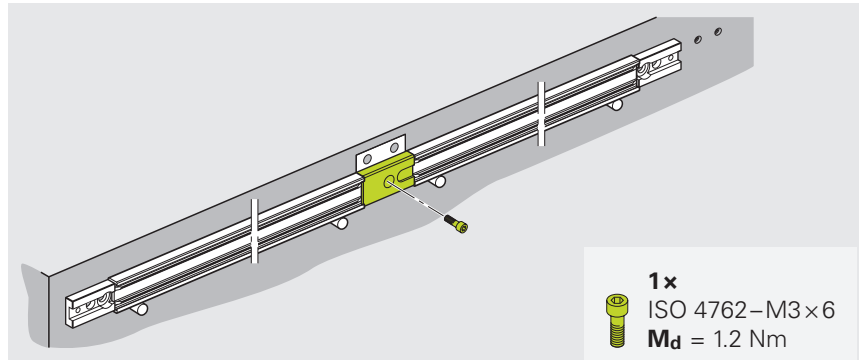

- ▶ Starting from the center, evenly press the scale-tape carriers onto the mounting surface using the roller

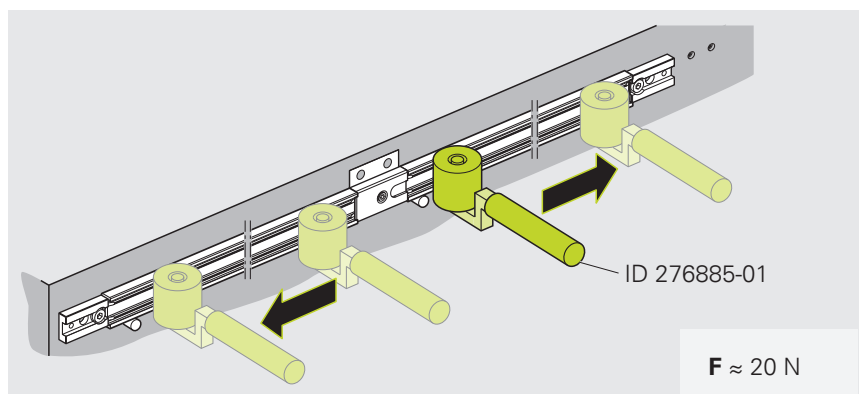

- ▶ Remove the stop pins
- ▶ Do not perform further work on the scale-tape carrier until the maximum adhesive force has been reached.



The maximum adhesive force of the mounting film is reached at room temperature after approx. 70 hours.

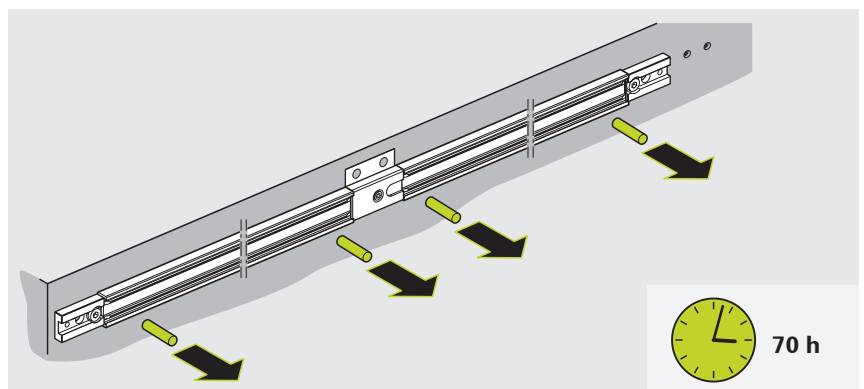

Mounting the scale tape

NOTICE

Property damage due to mechanical stress!

- ▶ Do not bend the scale tape

- ▶ If necessary, remove the protective film from the scale tape

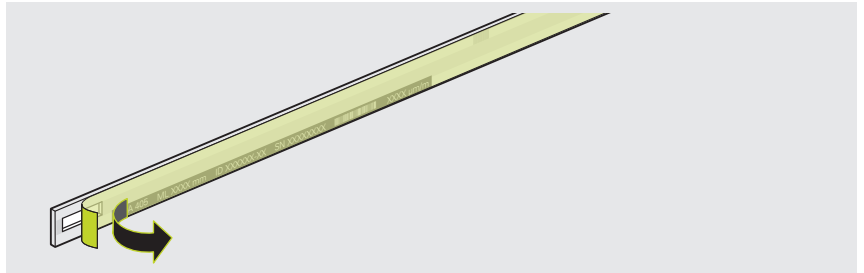

- ▶ Note down the shortening factor (V_k)

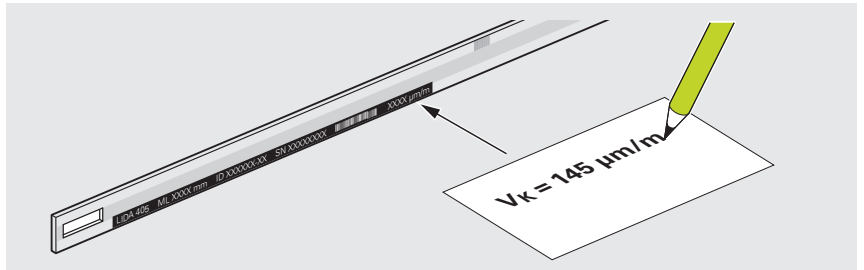

- ▶ Slide the scale tape into the scale tape carrier

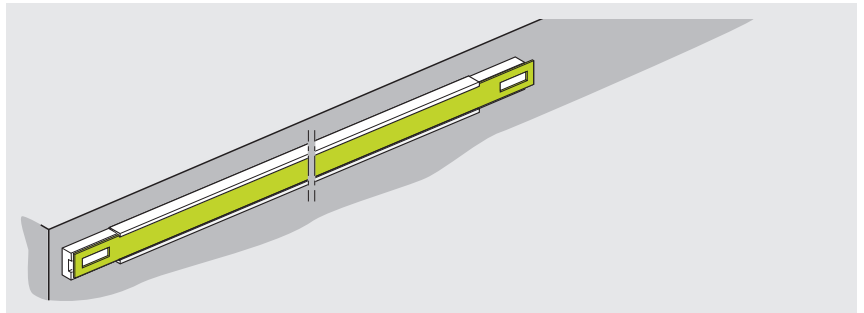

- ▶ Fasten the mounting block with the specified torque

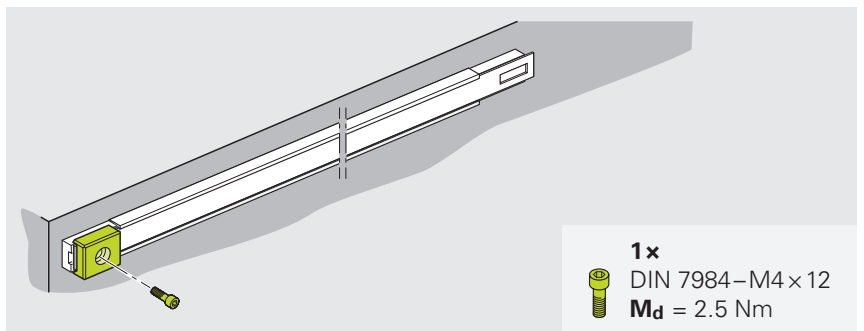

1 ×
 DIN 7984–M4 × 12
 $M_d = 2.5 \text{ Nm}$

- ▶ Hook the scale tape into the tensioning device
- ▶ Fasten the tensioning device with the specified torque

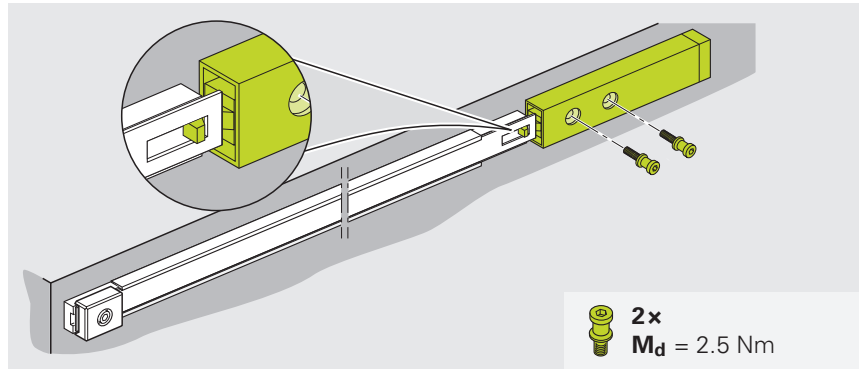

Next step: "Mounting the scanning head", Page 28

4.2.3 Variant: Mounting with screws

The mounting variant described in this chapter refers to mounting of the parts kit with screws.

An overview of the mounting variants is provided on Page 16.

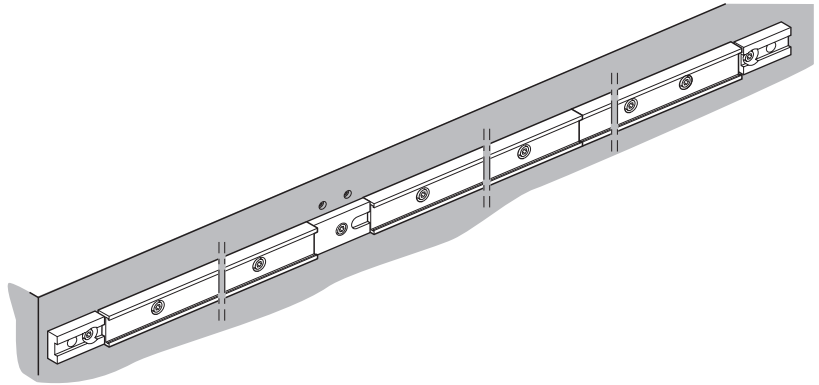

Notes on mounting with screws

The number of required components depends on the measuring length (ML).

ML	T1970 / Z
≤ 3040	0 x
≤ 5040	1 x
≤ 7040	2 x
≤ 9040	3 x
≤ 11 040	4 x
≤ 13 040	5 x
.	.
.	.
≤ 30 040	14 x

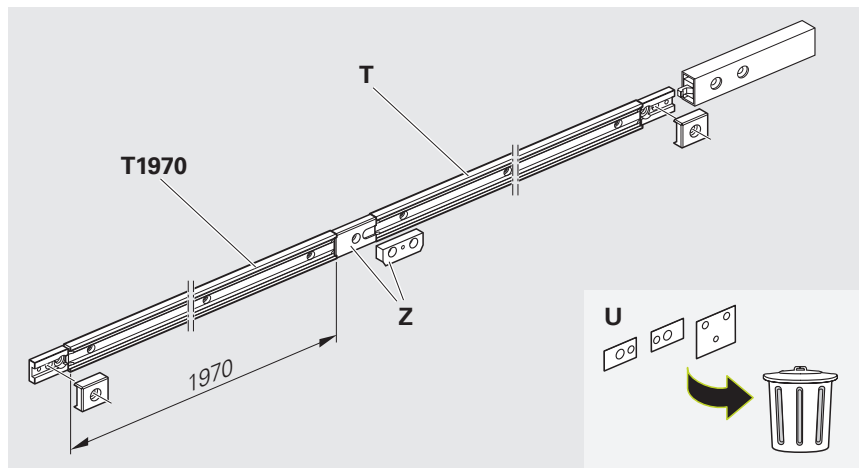

T1970 = Scale-tape carrier section with a length of 1970 mm

T = Remaining length of scale-tape carrier section

Z = Holder with fixing clamp

U = Shims for holders and spacers

Note that the mounting surface, as well as the surface of the scale, must be clean and free of paint, dust or grease.

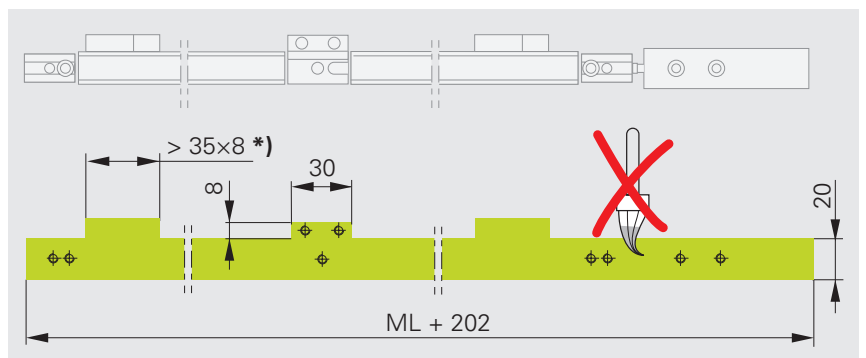

*) Mounting surface of the magnets for activating the limit switches

i You can mount the scale tape carriers by means of stop pins or an aligning rail.

The mounting tolerances refer to the machine guideway (**F**).

Comply with the specified dimensions to account for thermal expansion.

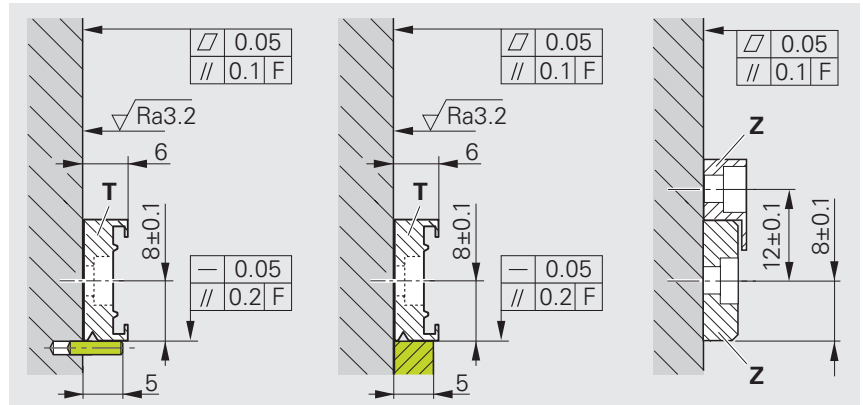

T = Scale-tape carrier section
Z = Holder with fixing clamp

ML ≤ 2040

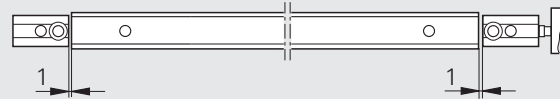

ML > 2040 – ≤ 3040

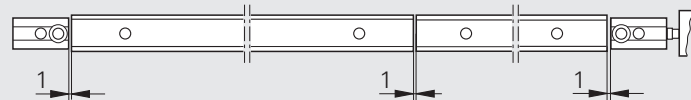

ML > 3040

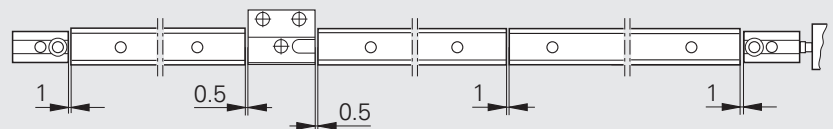

Materials and tools

For this task, the following materials and tools are needed:

Included in delivery

- Scale-tape carrier sections
- Holder and fixing clamp as needed
- Spacers and mounting blocks
- Tensioning device with screws

To be provided separately

- Screws (DIN 4762 – M3x6)
- Screws (DIN 7984 – M4x8)
- Torque wrench (hexagon socket for 2.5 mm)
- Torque wrench (hexagon socket for 3.5 mm)

Screw-fastening the scale tape carrier

The mounting tolerances refer to the machine guideway (**F**).

- ▶ Fasten the scale-tape carrier sections with the specified torque
- ▶ If holders are required, fasten them with the specified torque
- ▶ Fasten the spacers with the specified torque

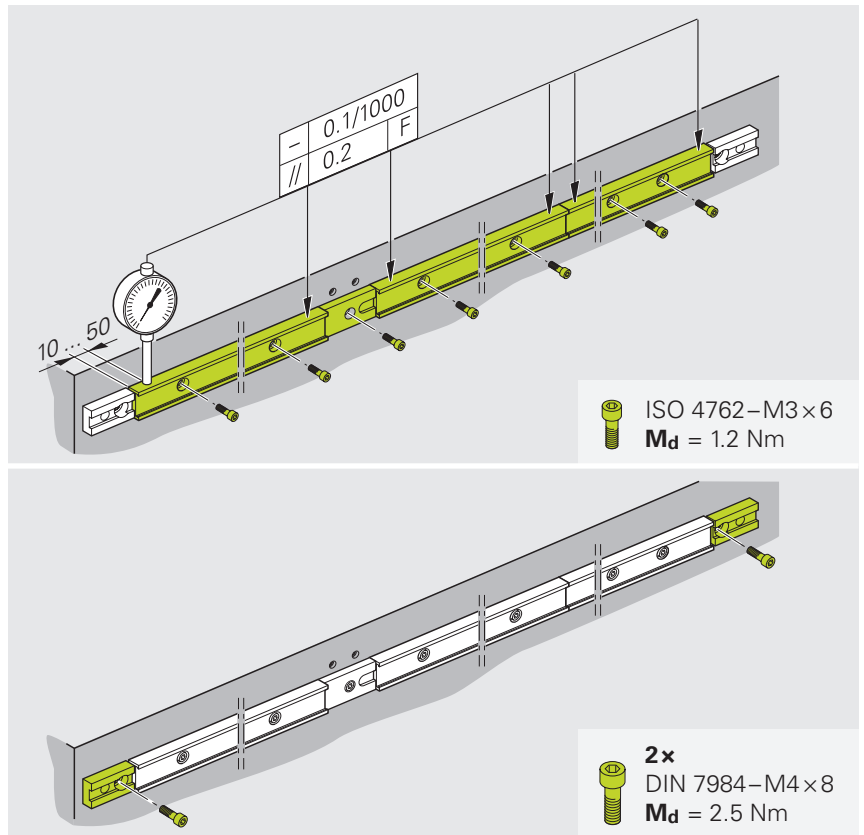

Mounting the scale tape

NOTICE**Property damage due to mechanical stress!**

- ▶ Do not bend the scale tape

- ▶ If necessary, remove the protective film from the scale tape

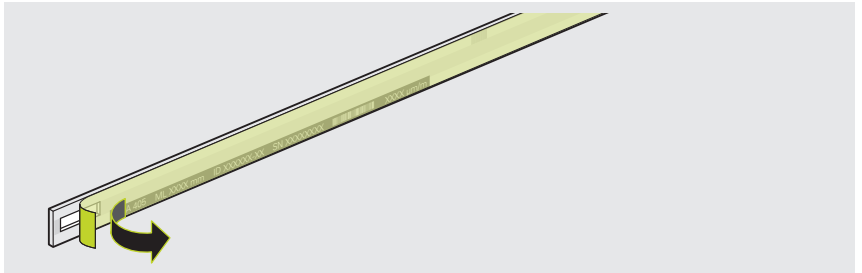

- ▶ Note down the shortening factor (V_K)

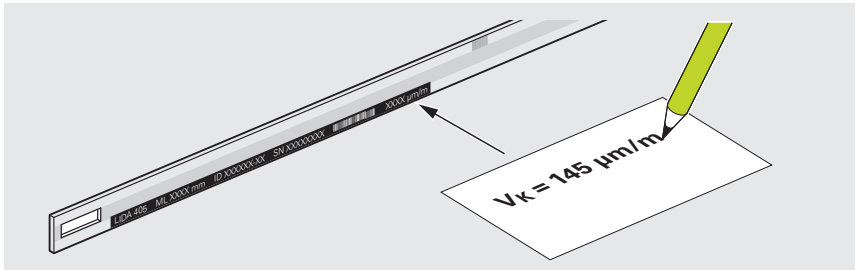

- ▶ Slide the scale tape into the scale tape carrier

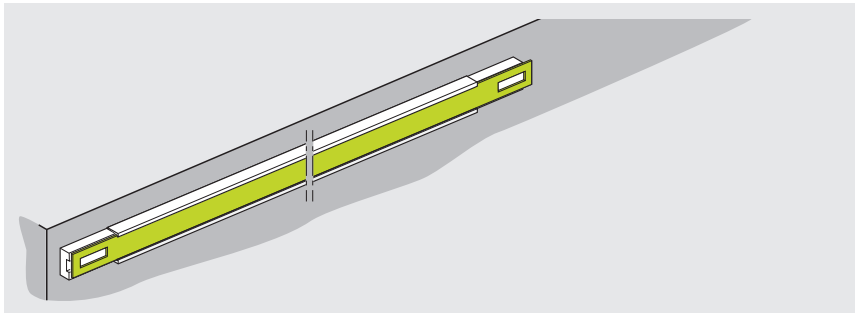

- ▶ Fasten the mounting block with the specified torque

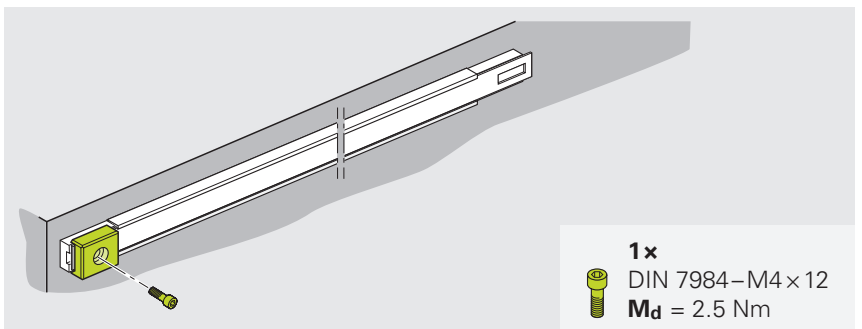

- ▶ Hook the scale tape into the tensioning device
- ▶ Fasten the tensioning device with the specified torque

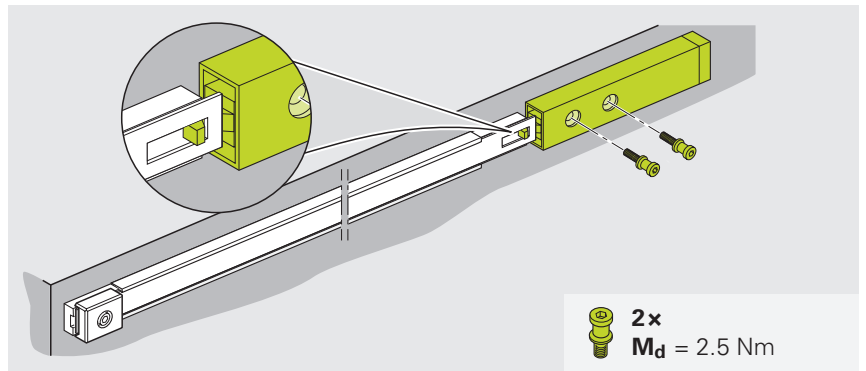

Next step: "Mounting the scanning head", Page 28

4.3 Mounting the scanning head

4.3.1 Choosing the mounting variant

Mounting variants for the scanning head

Holder **on the side**

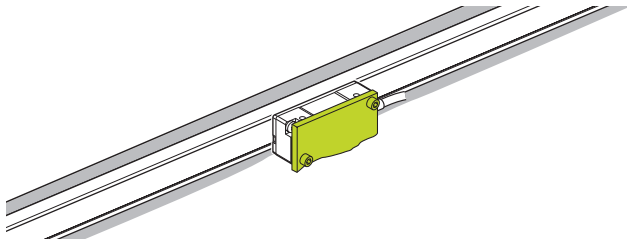

Page 29

Holder **at the top**

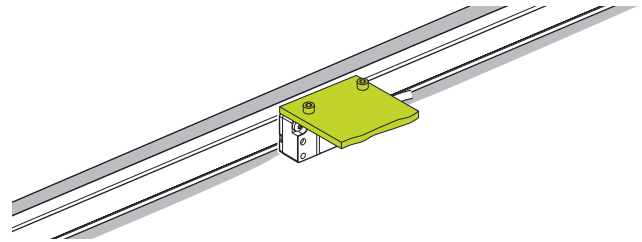

Page 31

Holder at the **bottom**

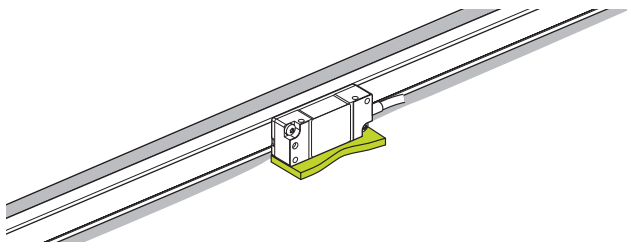

Page 33

4.3.2 Variant: Mounting with the holder on the side

The mounting variant described in this chapter refers to mounting of the scanning head with the holder on the side.

An overview of the mounting variants is provided on Page 28.

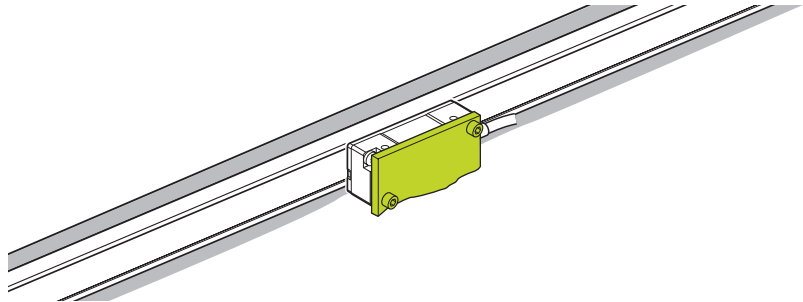

Notes on mounting the scanning head with the holder on the side

i The tightening torques of the mounting screws are only valid for mounting on steel.

NOTICE

Property damage due to unsuitable cleaning agents!

- ▶ Use only isopropyl alcohol to clean the encoder
- ▶ Clean the encoder with a lint-free cloth

▶ If necessary, clean the graduation and the scanning head with a lint-free cloth and isopropyl alcohol

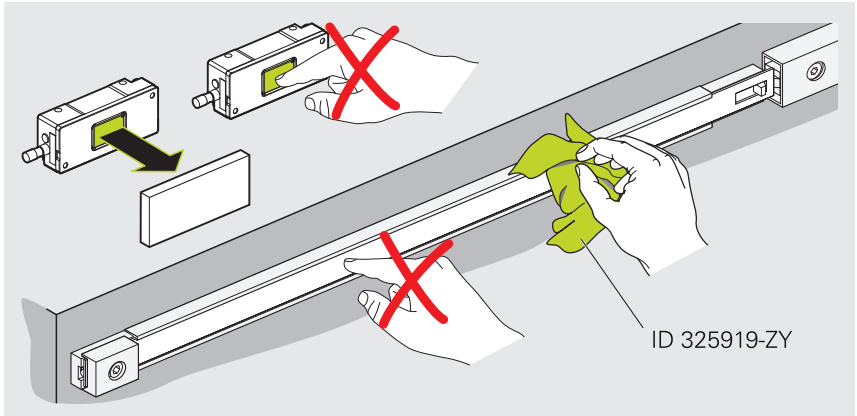

Pay attention to the mounting dimensions. Deviations from the mounting dimensions lead to imprecise measurement results during operation.

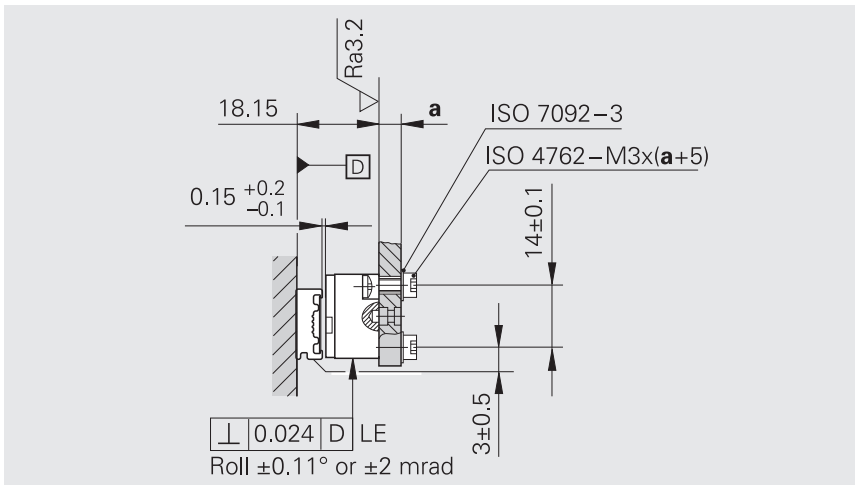

Materials and tools

For this task, the following materials and tools are needed:

Included in delivery

- Spacer shim

To be provided separately

- Two screws (ISO 4762–M3×(a+5))
- Two washers (ISO 7092–3)
- Torque wrench (hexagon socket for 2.5 mm)

Mounting the scanning head

- ▶ If necessary, remove the protective cap from the scanning head

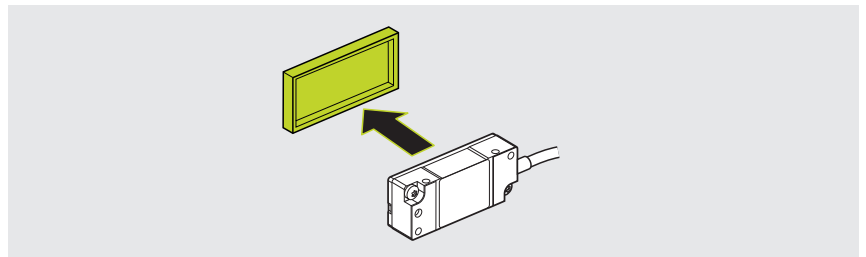

- ▶ Prepare the spacer shim

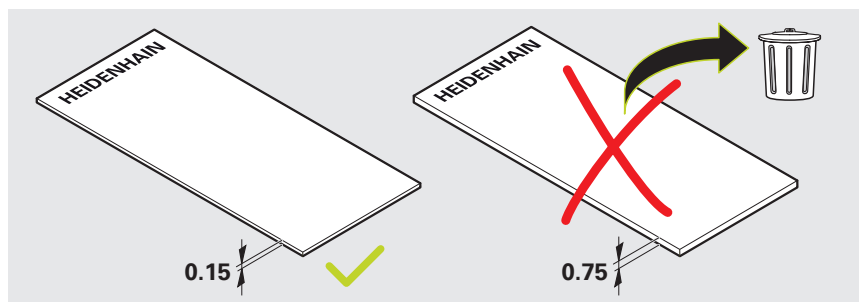

- ▶ If necessary, clean the spacer shim with a lint-free cloth and isopropyl alcohol
- ▶ Use the spacer shim to set the mounting clearance
- ▶ Lightly tighten the screws on the scanning head
- ▶ Remove the spacer shim

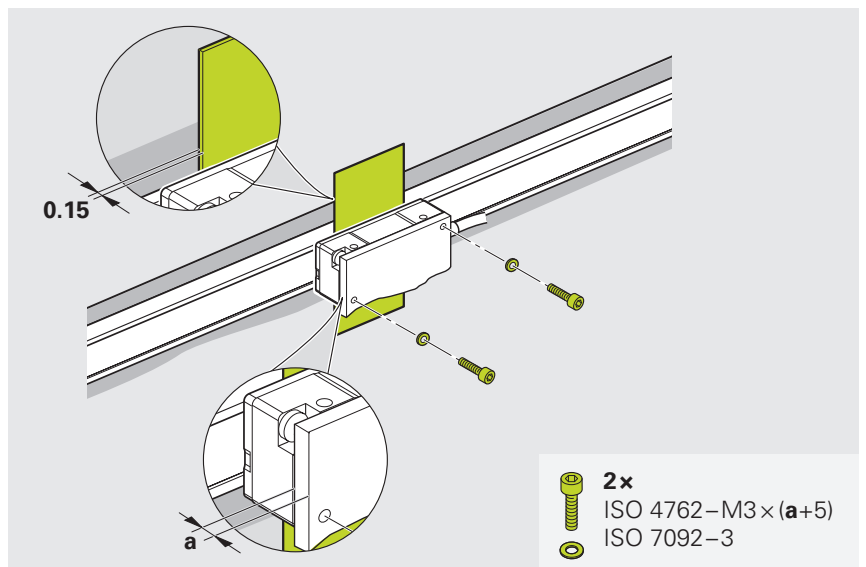

Next step: "Adjustment and diagnosis", Page 35

4.3.3 Variant: Mounting with the holder at top

The mounting variant described in this chapter refers to mounting of the scanning head with the holder at top.

An overview of the mounting variants is provided on Page 28.

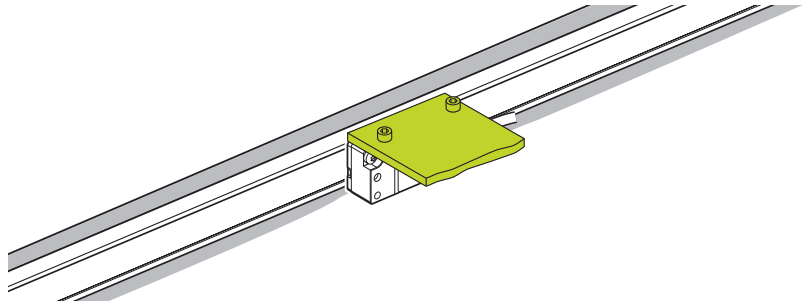

Notes on mounting the scanning head with the holder at top

i The tightening torques of the mounting screws are only valid for mounting on steel.

NOTICE

Property damage due to unsuitable cleaning agents!

- ▶ Use only isopropyl alcohol to clean the encoder
- ▶ Clean the encoder with a lint-free cloth

- ▶ If necessary, clean the graduation and the scanning head with a lint-free cloth and isopropyl alcohol

Pay attention to the mounting dimensions. Deviations from the mounting dimensions lead to imprecise measurement results during operation.

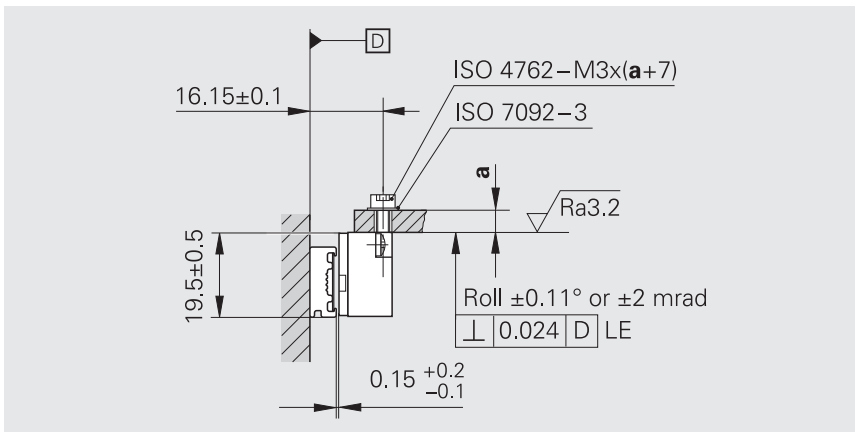
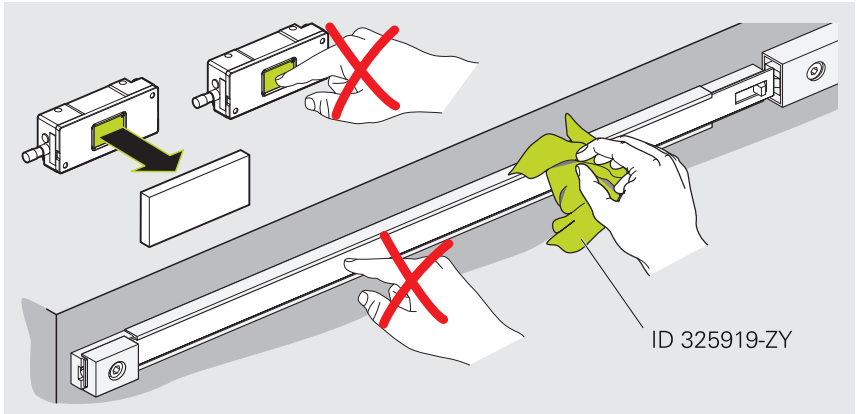

Materials and tools

For this task, the following materials and tools are needed:

Included in delivery

- Spacer shim

To be provided separately

- Two screws (ISO 4762–M3×(a+7))
- Two washers (ISO 7092–3)
- Torque wrench (hexagon socket for 2.5 mm)

Mounting the scanning head

- ▶ If necessary, remove the protective cap from the scanning head

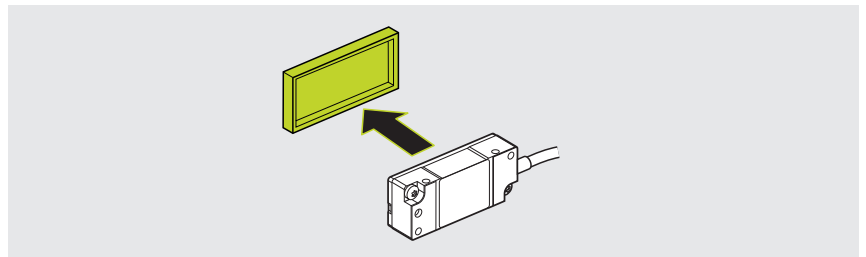

- ▶ Prepare the spacer shim

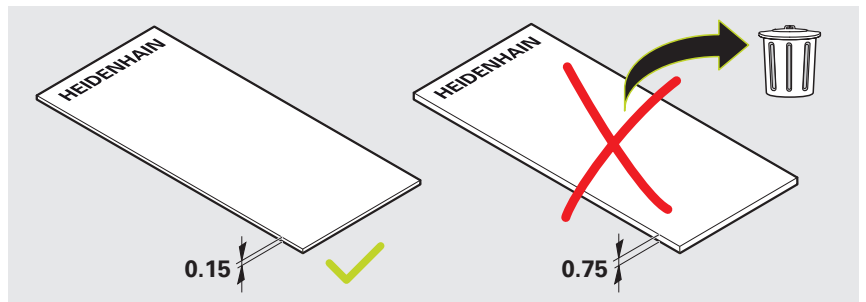

- ▶ If necessary, clean the spacer shim with a lint-free cloth and isopropyl alcohol
- ▶ Use the spacer shim to set the mounting clearance
- ▶ Lightly tighten the screws on the scanning head
- ▶ Remove the spacer shim

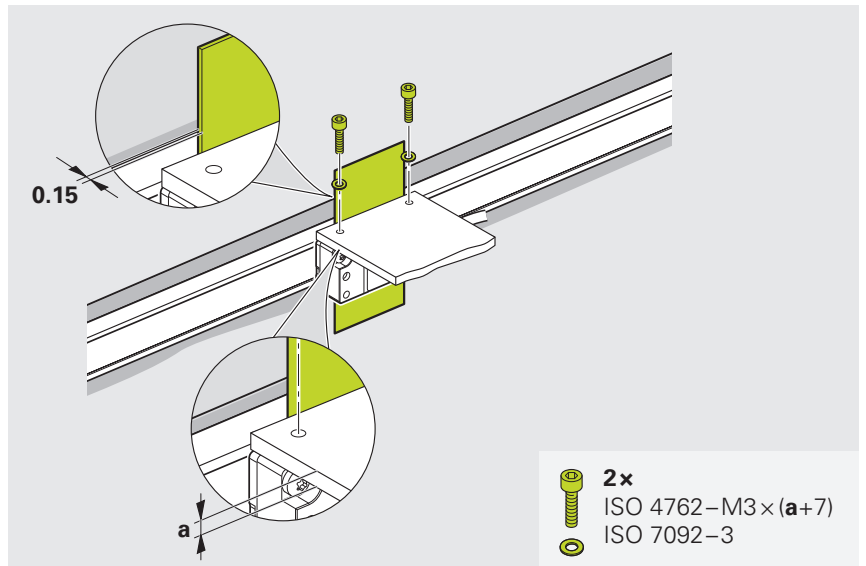

Next step: "Adjustment and diagnosis", Page 35

4.3.4 Variant: Mounting with the holder at bottom

The mounting variant described in this chapter refers to mounting of the scanning head with the holder at bottom.

An overview of the mounting variants is provided on Page 28.

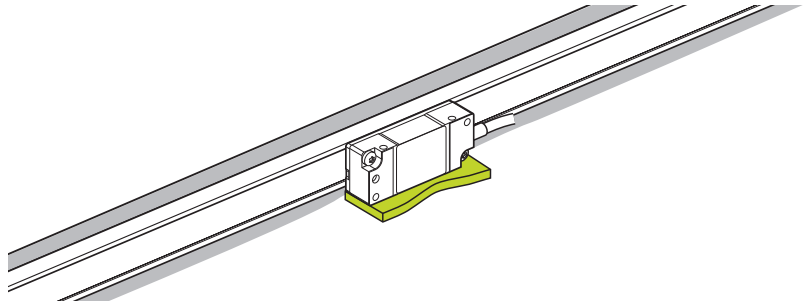

Notes on mounting the scanning head with the holder at bottom

i The tightening torques of the mounting screws are only valid for mounting on steel.

NOTICE

Property damage due to unsuitable cleaning agents!

- ▶ Use only isopropyl alcohol to clean the encoder
- ▶ Clean the encoder with a lint-free cloth

▶ If necessary, clean the graduation and the scanning head with a lint-free cloth and isopropyl alcohol

Pay attention to the mounting dimensions. Deviations from the mounting dimensions lead to imprecise measurement results during operation.

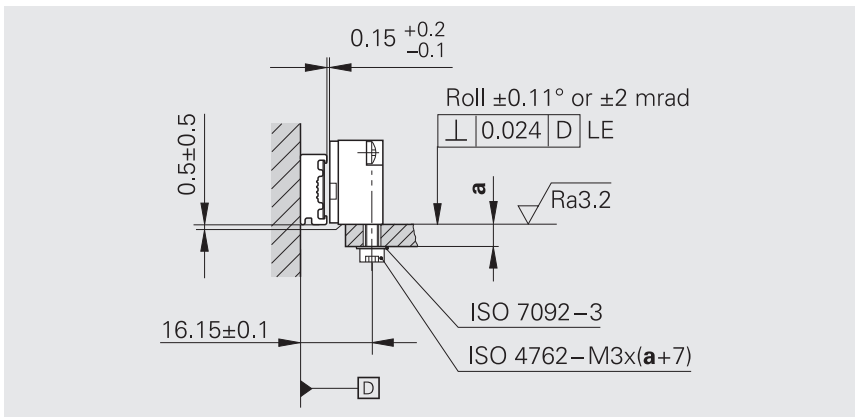
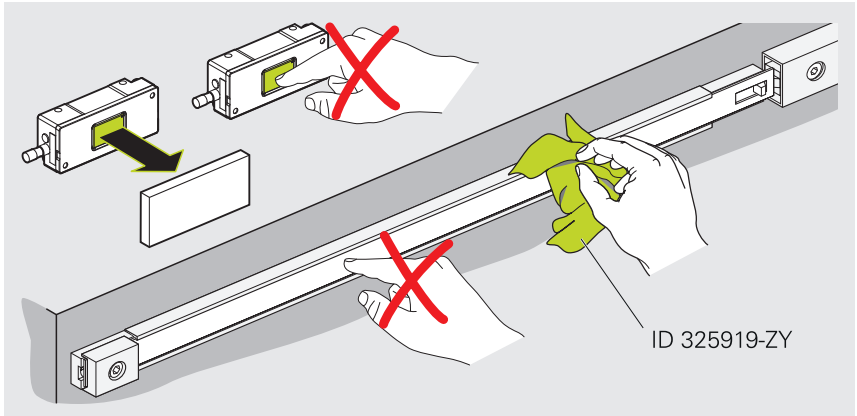

Materials and tools

For this task, the following materials and tools are needed:

Included in delivery

- Spacer shim

To be provided separately

- Two screws (ISO 4762–M3×(a+7))
- Two washers (ISO 7092–3)
- Torque wrench (hexagon socket for 2.5 mm)

Mounting the scanning head

- ▶ If necessary, remove the protective cap from the scanning head

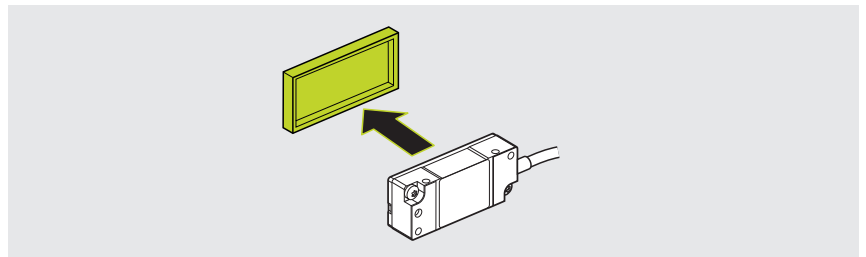

- ▶ Prepare the spacer shim

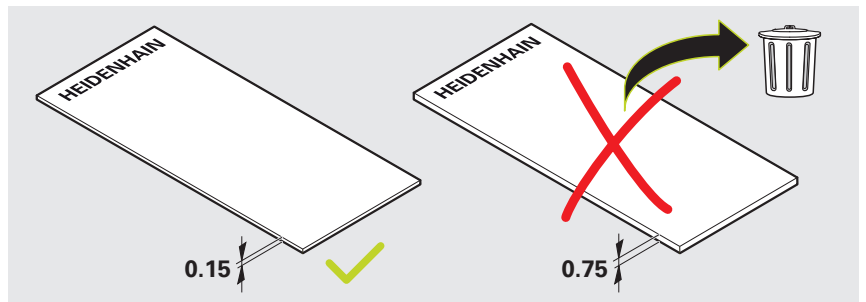

- ▶ If necessary, clean the spacer shim with a lint-free cloth and isopropyl alcohol
- ▶ Use the spacer shim to set the mounting clearance
- ▶ Lightly tighten the screws on the scanning head
- ▶ Remove the spacer shim

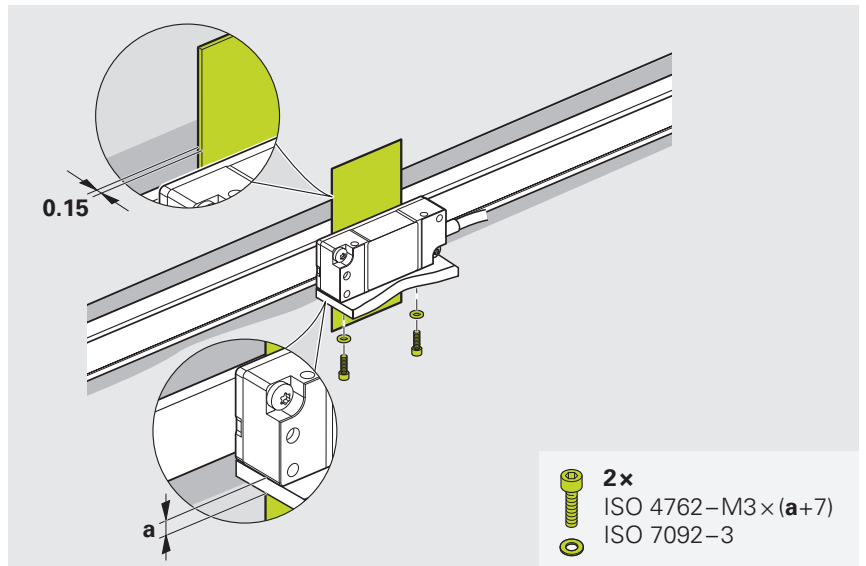

Next step: "Adjustment and diagnosis", Page 35

5 Adjustment and diagnosis

This chapter describes the continuity test, as well as the adjustment and diagnosis with a testing device (e.g., PWT 101).

5.1 Requirements and notes

A testing device (e.g., PWT 101) is required for adjustment and diagnosis. As an alternative, an inspection device (e.g., PWM 21) can be used.



For more information, refer to the **PWT 100/PWT 101** Operating Instructions.

- ▶ www.heidenhain.com/documentation
- ▶ Enter the document ID **1162581**



For more information, see the **Exposed Linear Encoders** brochure.

- ▶ www.heidenhain.com/documentation
- ▶ Enter the document ID **208960**

5.2 Continuity check

5.2.1 Materials and tools

For this mounting step, the following materials and tools are needed:

Included in delivery

To be provided separately

- Resistance measuring device

5.2.2 Measuring the electrical resistance

- ▶ Check the electrical resistance between the connector housing and the machine



The electrical resistance between the connector housing and the machine must be $< 1 \Omega$.

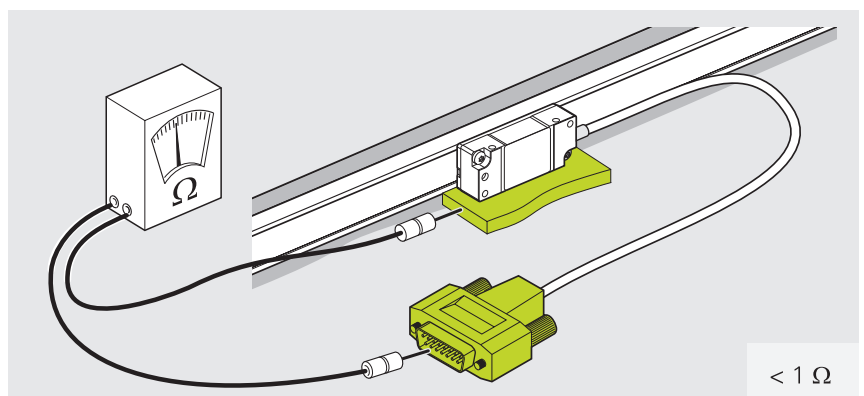

5.3 Selecting the scanning head

Scanning head variants	
LIDA 47	LIDA 48
Scanning head with TTL interface Page 37	Scanning head with 1 V _{PP} interface Page 53

5.4 Adjustment and diagnosis of LIDA 47

5.4.1 Connecting the encoder to the PWT

Connecting the encoder

NOTICE

Property damage due to electrical stress!

- ▶ Do not engage or disengage any connecting elements while the product is under power

- ▶ Connect the encoder to the PWT 101
- ▶ Connect the PWT 101 to the power supply

Selecting the connection

Connection options

Connecting the encoder automatically	Connecting the encoder manually
Recommended option with automatic determination of the measuring parameters. Page 38	Alternative option if the encoder cannot be connected automatically. Page 39

Connecting the encoder automatically

- ▶ Tap **Automatic Diagnosis** in the main menu
- > The **Automatic Diagnosis** is performed.
- > The **Level display** screen is opened.

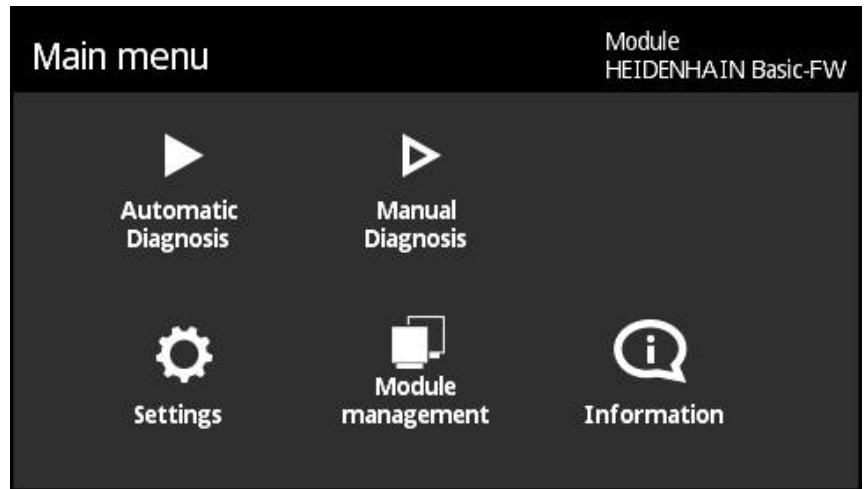
**Main menu**

If you cannot connect the encoder automatically, proceed as described in the **Connecting the encoder manually** chapter.

Next step: "Adjusting the scanning head", Page 41

Connecting the encoder manually

- ▶ Tap **Manual diagnostics** in the main menu
- ▶ The **Supply voltage of encoder** screen is opened.

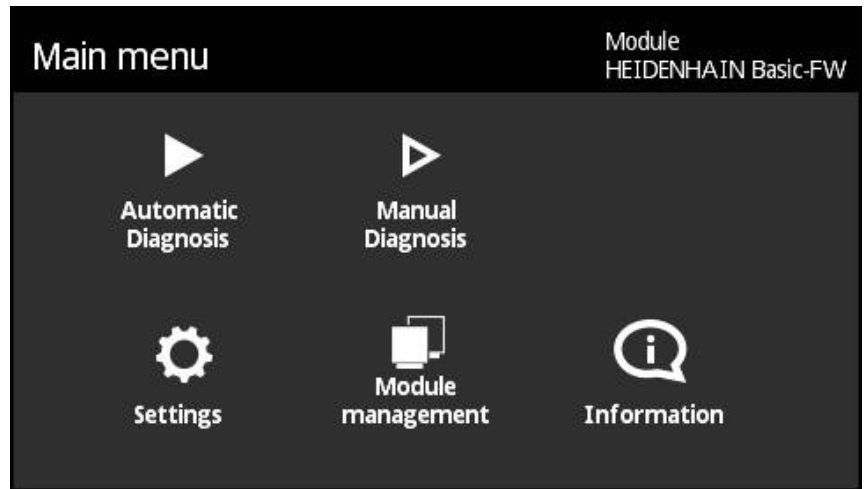

Main menu

- ▶ Select the supply voltage
- ▶ Activate the **Adjust supply voltage** checkbox, if required
- ▶ Swipe right to left
- ▶ The **Encoder interface** screen is opened.

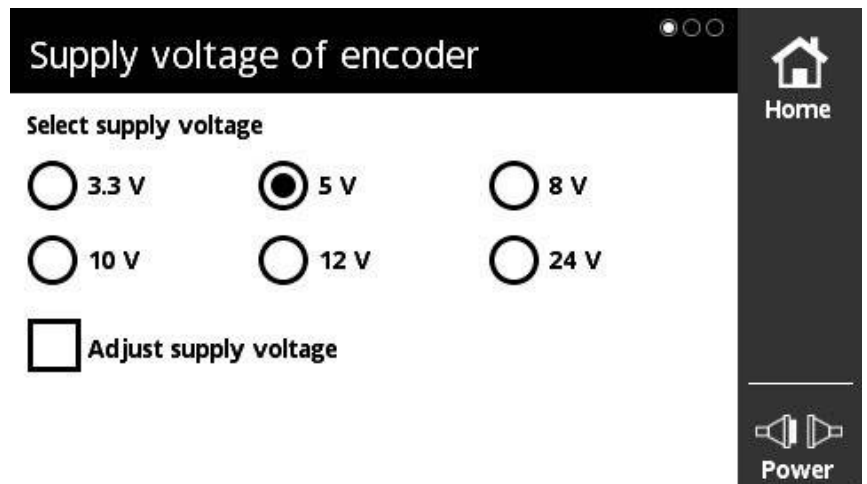

Supply voltage of encoder screen

- ▶ Select the encoder interface
- ▶ Swipe right to left
- ▶ The **Manual diagnostics** screen is opened.

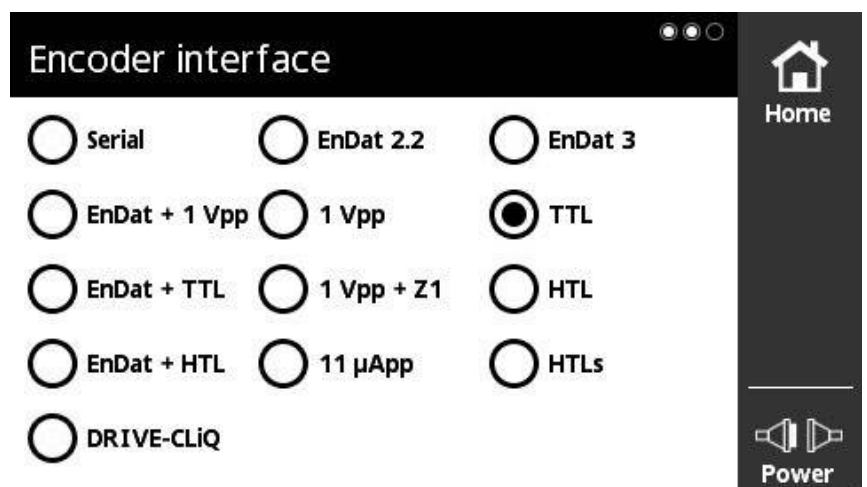

Encoder interface screen

- ▶ Check your selection
- ▶ Tap **Connect**
- > The connection to the encoder is established.
- > The **Level display** screen is opened.

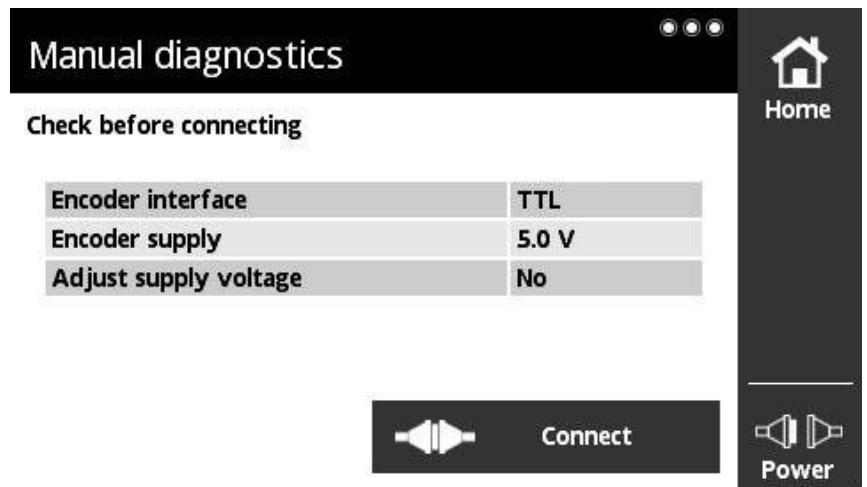

Manual Diagnosis screen

Next step: "Adjusting the scanning head", Page 41

5.4.2 Adjusting the scanning head

- ▶ Swipe the **Level display** screen to the right
- > The **PWT display** screen is opened.

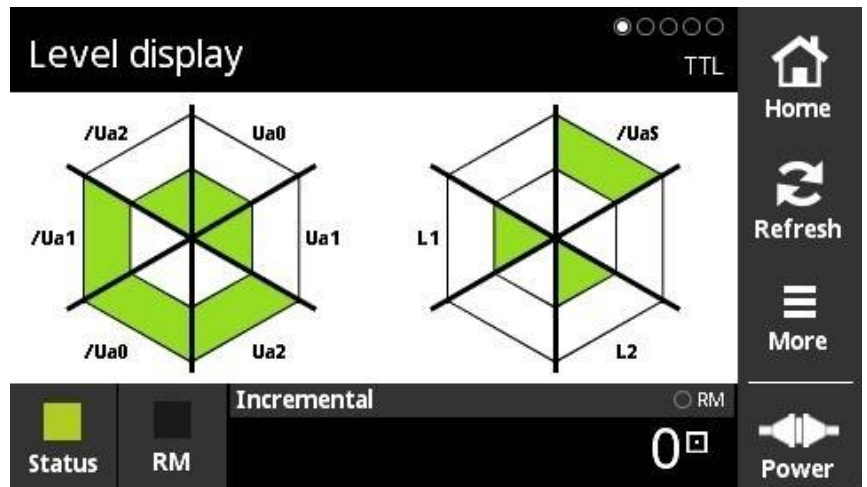

Level display screen

In the **PWT display** screen, you can evaluate the incremental and reference mark signals based on the bar diagrams. HSP is automatically deactivated in the **PWT display** screen.

- *) If **HSP OFF** blinks, then HSP is deactivated.

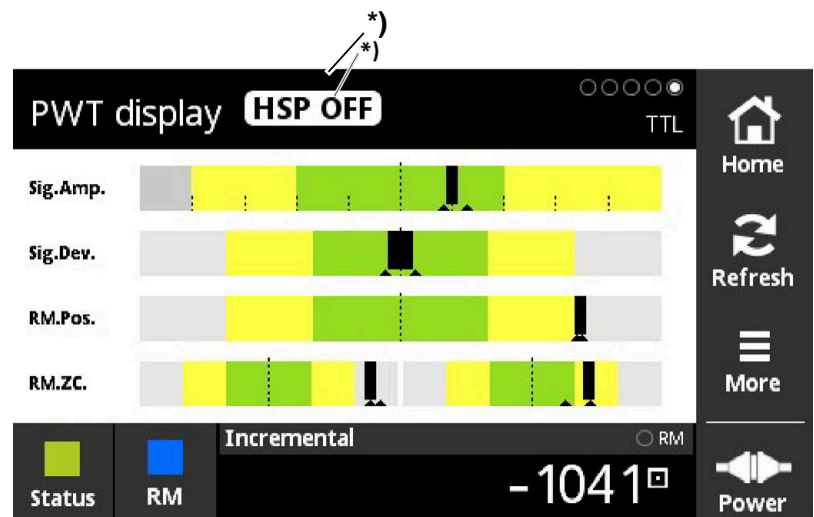

PWT display screen

i For the mounting variant with the holder on the side, the blind hole in the scanning head can be used for the adjustment.

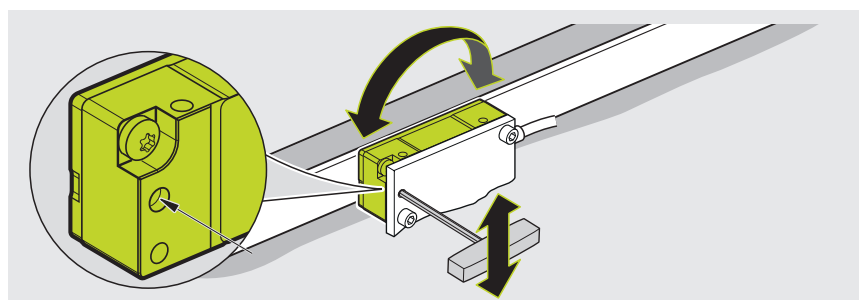

Setting the incremental signal

The black bar represents the current signal amplitude of the incremental signals. The farther the black bar moves to the right, the larger the signal amplitude is.

- ▶ Rotate the scanning head to set the maximum possible signal amplitude

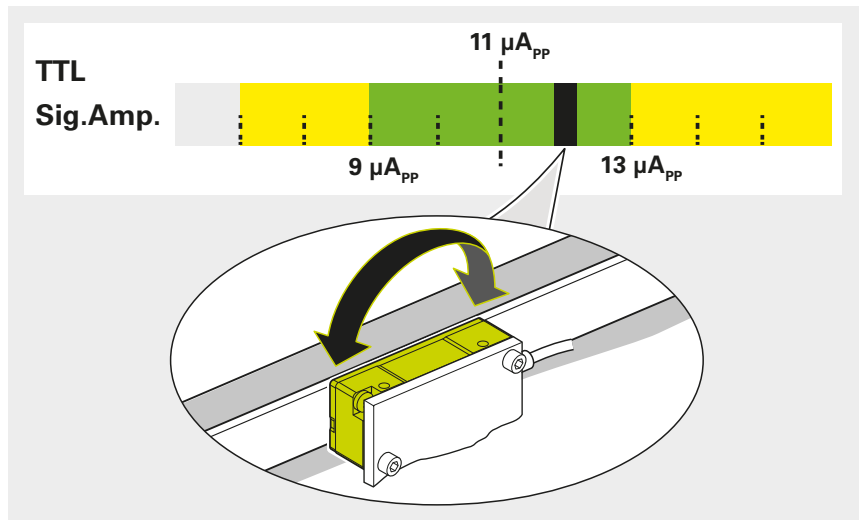

- ▶ Lightly tighten the screws

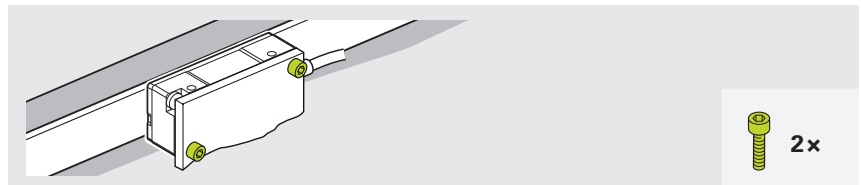

Set the reference mark signal

- ▶ Traverse the reference mark (R) with the scanning head

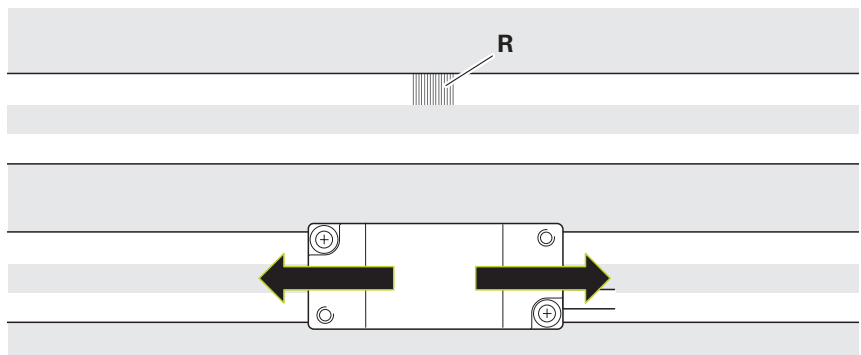

- ▶ Tap lightly to rotate the scanning head a minimum distance to set the optimal reference mark signals.

*) Green = good

***) Optimal

- ▶ Ensure that the incremental signals do not decrease

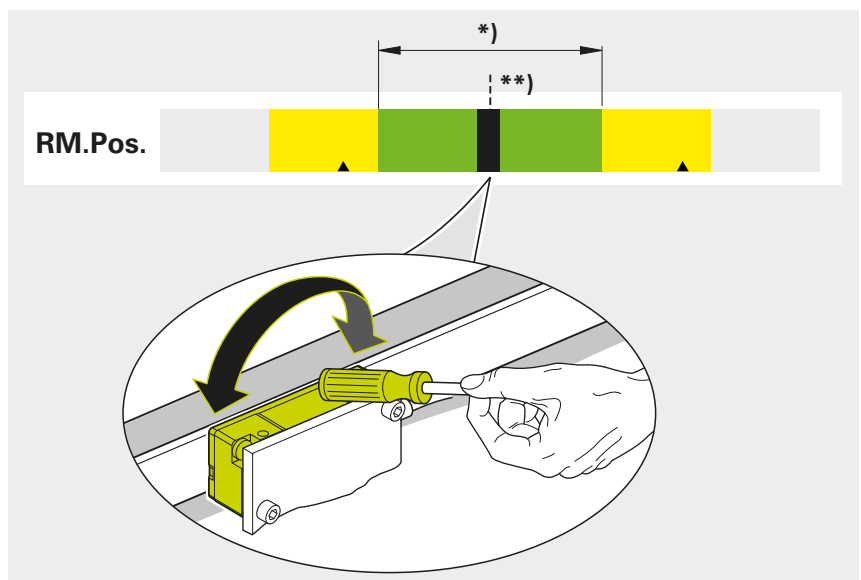

- ▶ Tighten the screws with the specified torque

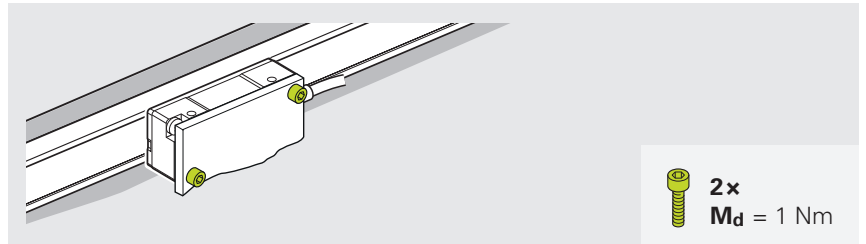

5.4.3 Checking the function indicator

The function indicator permits fast and easy signal-quality checks.

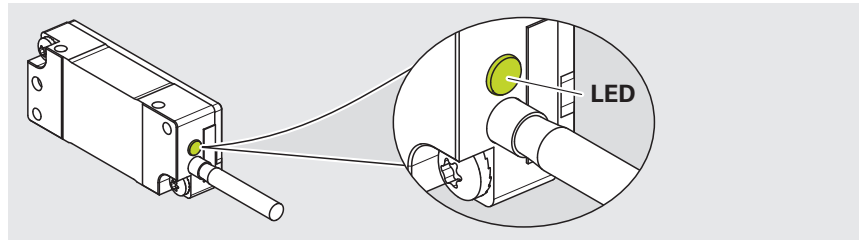

If the LED blinks green after adjustment, proceed as follows:

- ▶ Clean the measuring standard and the scanning window of the scanning head
- ▶ Check the mounting tolerance
- ▶ Repeat adjustment

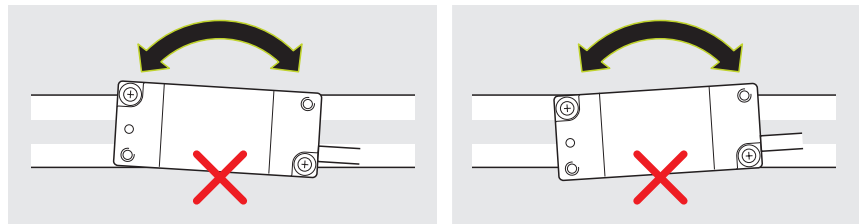

LED blinks

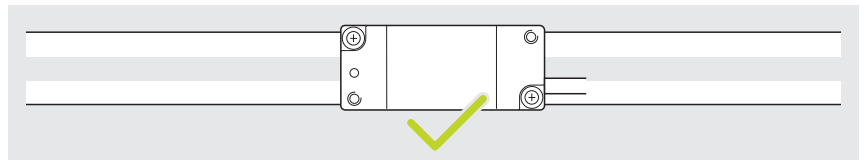

LED shines green



For more information, see the **Exposed Linear Encoders** brochure.

- ▶ www.heidenhain.com/documentation
- ▶ Enter the document ID **208960**

5.4.4 Tensioning the scale tape

Use the PWT 101 testing device to tension the scale tape.

Tensioning the scale tape

- ▶ Tap **Automatic Diagnosis** in the main menu
- > The **Automatic Diagnosis** is performed.
- > The **Level display** screen is opened.

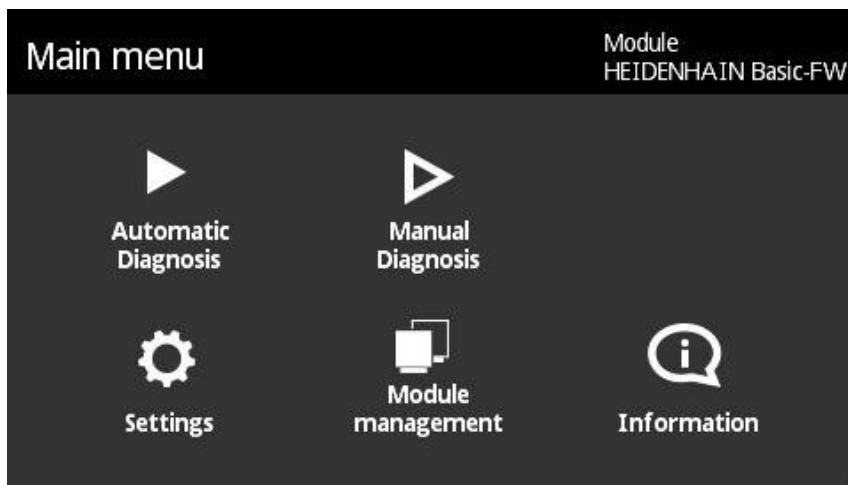

Main menu

- ▶ Tap **More**
- > The **More** menu is opened.
- ▶ Tap **Units**
- > The **Display settings** screen is opened.

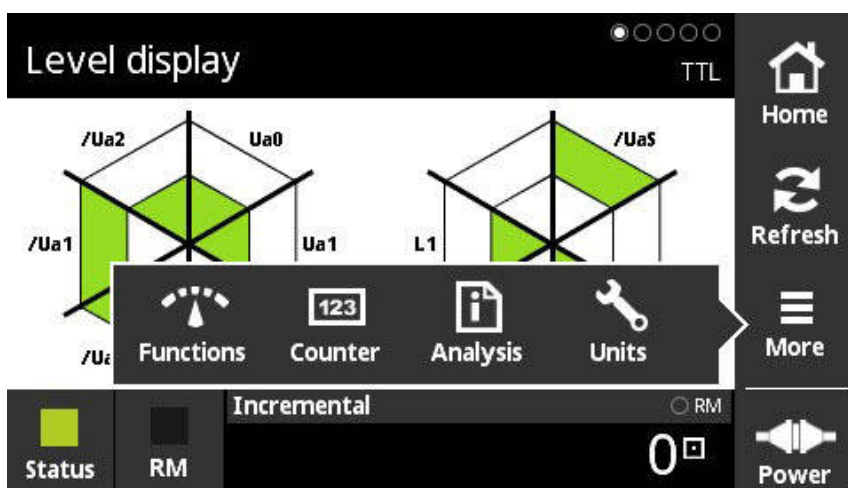

Level display screen > More menu

- ▶ Tap the **Linear** option
- ▶ Read the TTL value on the scanning head
- ▶ Determine the μm value according to the table
- ▶ Enter the applicable μm value in the **Signal period including interpolation** input field
- ▶ Tap **Back**
- ▶ The **Level display** screen is opened.

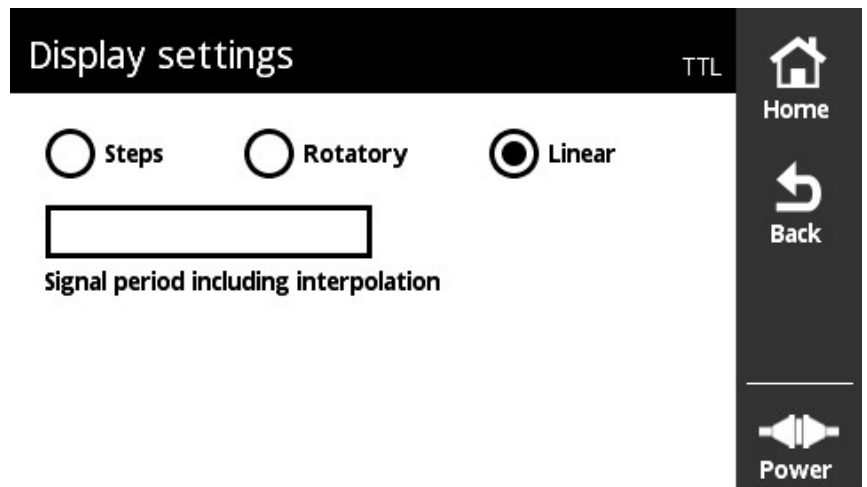

Display settings screen

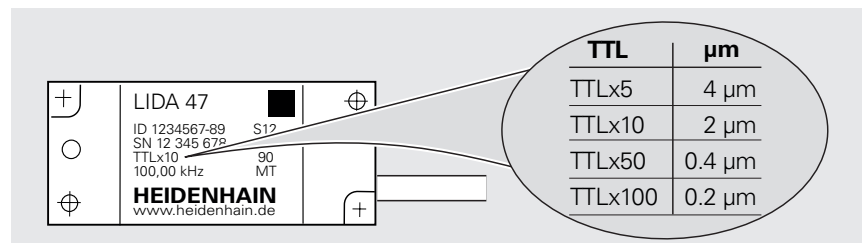

- ▶ Push the scanning head in the direction of the tensioning device up to the end of the measuring length

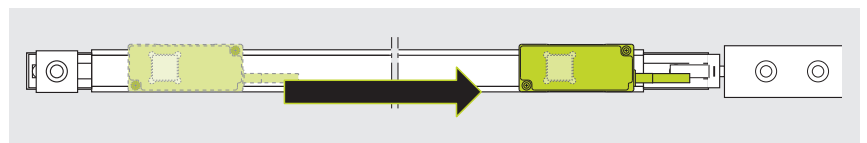

The values stated here are exemplary values.

- ▶ Replace the stated values with customer-specific parameters

- ▶ Measure the distance (X_V) between the center of the mounting block and the center of the scanning window and note it down

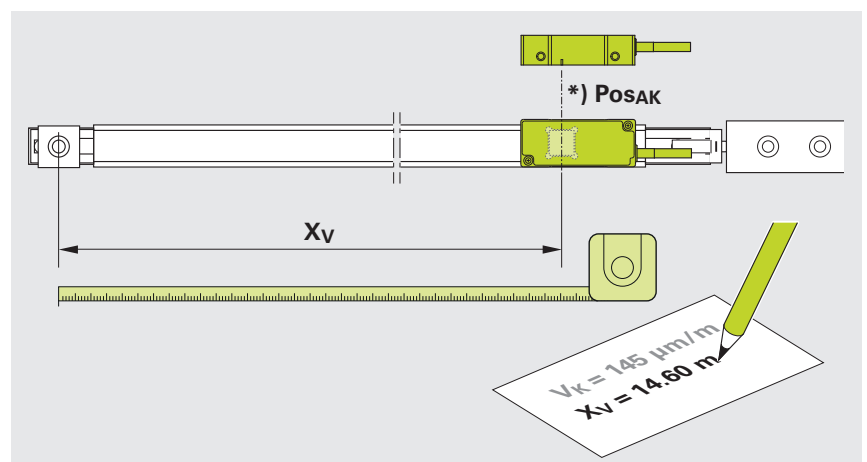

*) POS_{AK} = Position of scanning head

- ▶ Tap **More**
- > The **More** menu is opened.
- ▶ Tap **Counter**
- > The **Display options for count value** screen is opened.

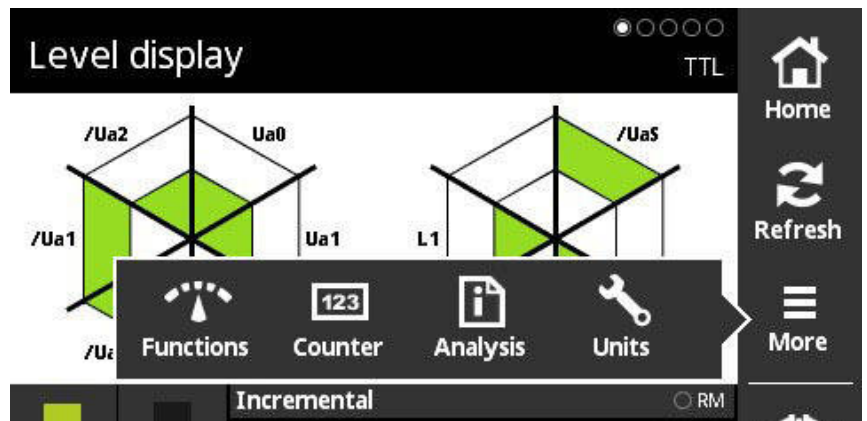

Level display screen > More menu

- ▶ Tap the **Manual** option for the **Set the count value:** parameter
- ▶ Enter the value 0 in the **Position [μm]** input field (zeroing)
- ▶ Tap **Back**
- > The **Level display** screen is opened.

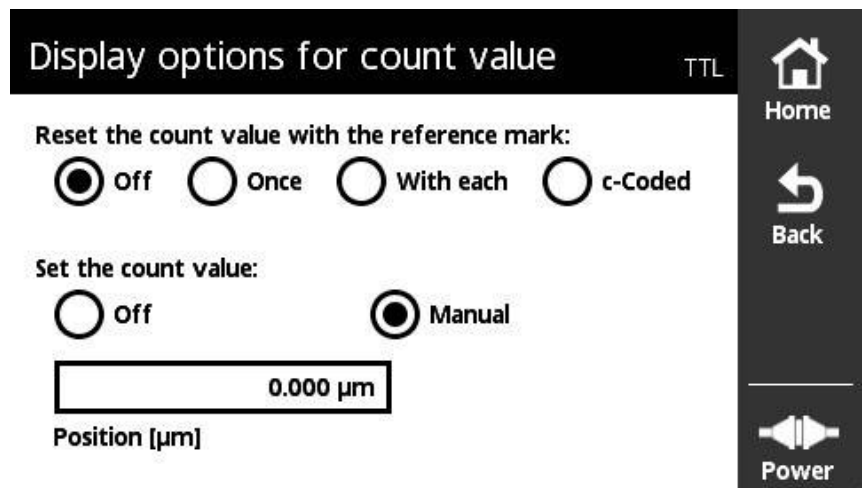

Display options for count value screen

- ▶ Tension the scale tape by 50 μm
- ▶ Remove the tension from the scale tape

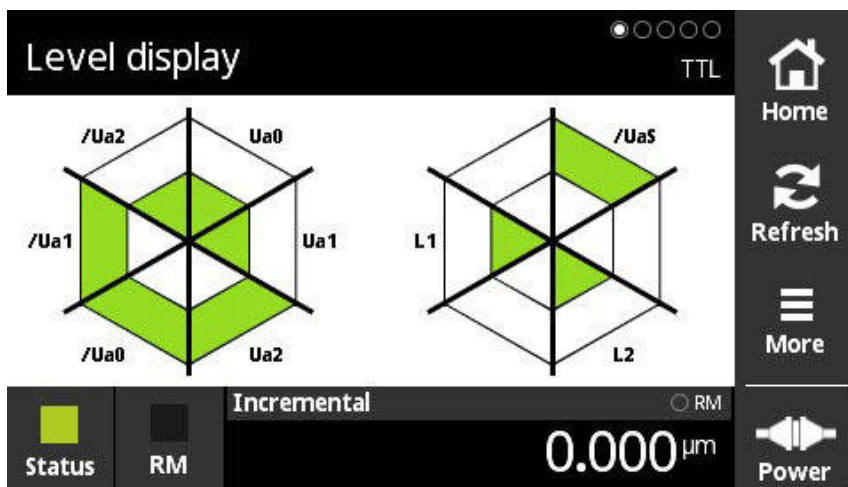

Level display screen

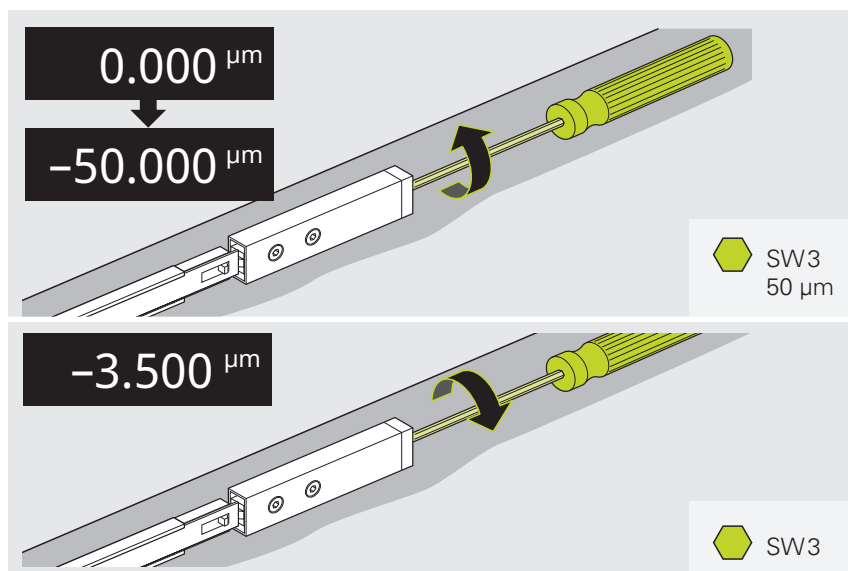

- ▶ Tap **More**
- ▶ The **More** menu is opened.
- ▶ Tap **Counter**
- ▶ The **Display options for count value** screen is opened.

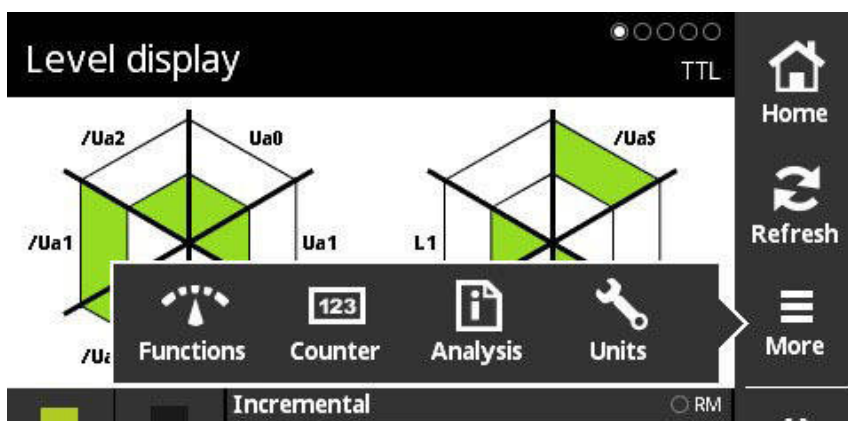

Level display screen > More menu

- ▶ Tap the **Manual** option for the **Set the count value:** parameter
- ▶ Enter the value 0 in the **Position [μm]** input field (zeroing)
- ▶ Tap **Back**
- ▶ The **Level display** screen is opened.

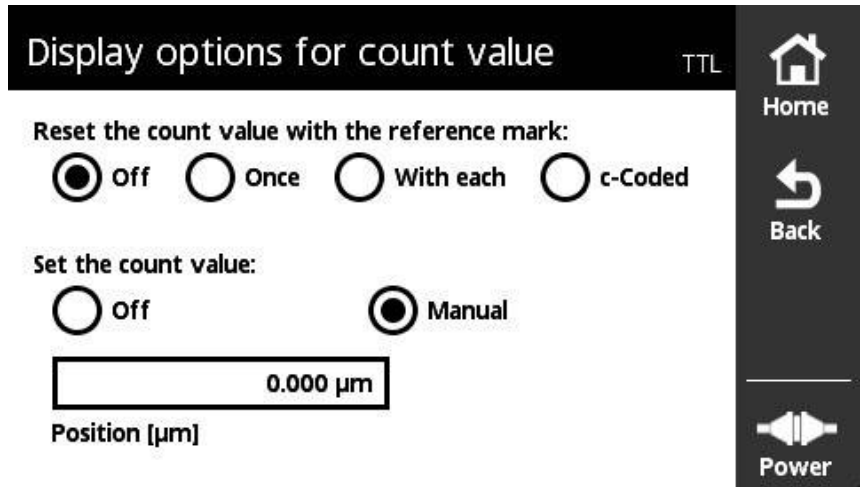

Display options for count value screen

- ▶ Calculate the tensioning value **A**

i V_K = Previously noted-down shortening factor of the scale tape being used

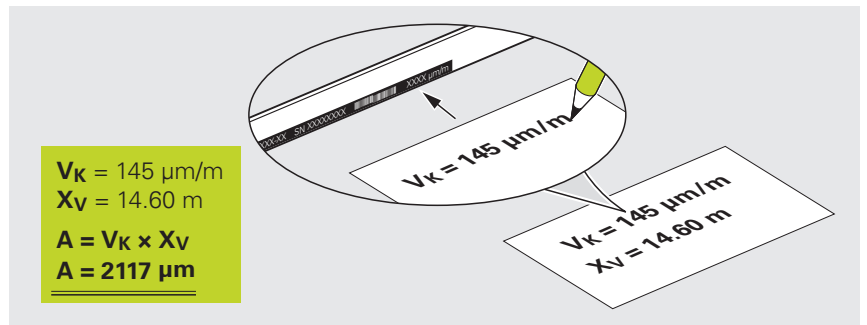

Calculation example

- ▶ Tension the scale tape until the calculated tensioning value has been reached

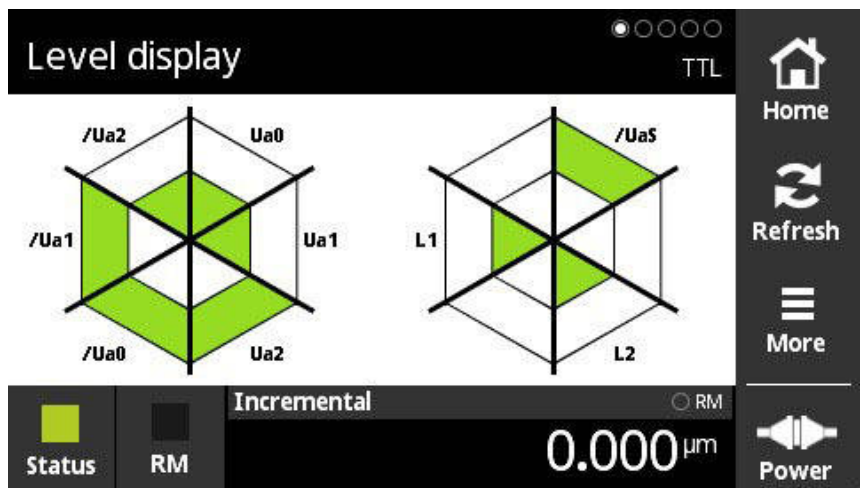

Level display screen

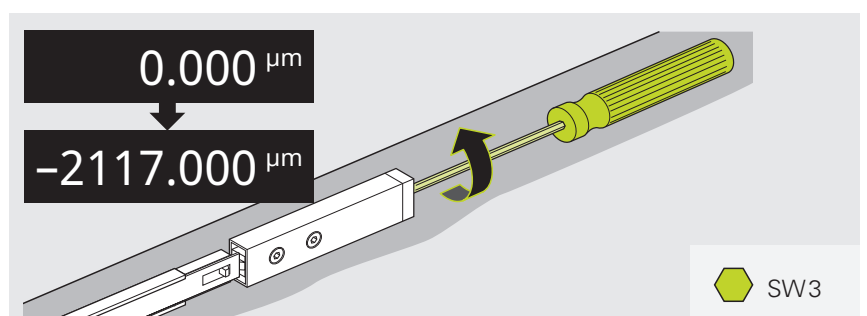

- ▶ Lightly tap the scale-tape carrier sections to release any tension
- ▶ Check the tensioning value
- ▶ If the clamping value differs from the calculated clamping value, re-tension the scale tape

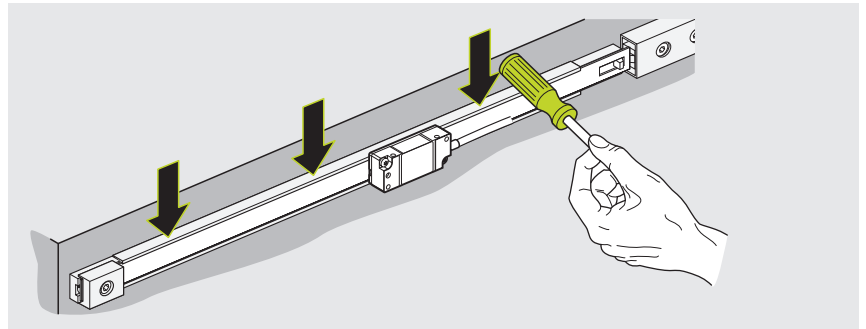

- ▶ If a fixing clamp (**Z**) is needed, fasten it with the specified torque

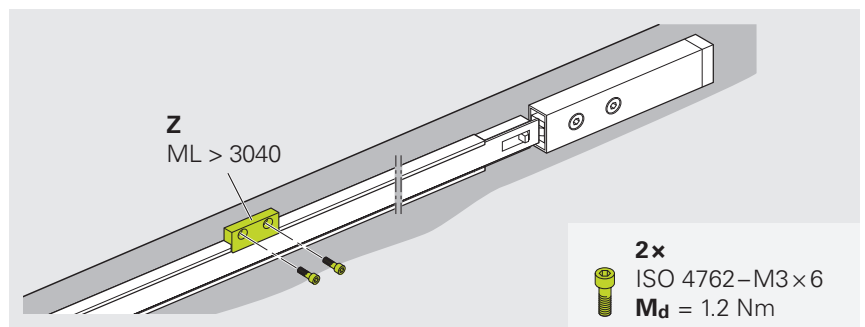

- ▶ Fasten the mounting block with the specified torque



You can leave the tensioning device mounted, or you can remove it.

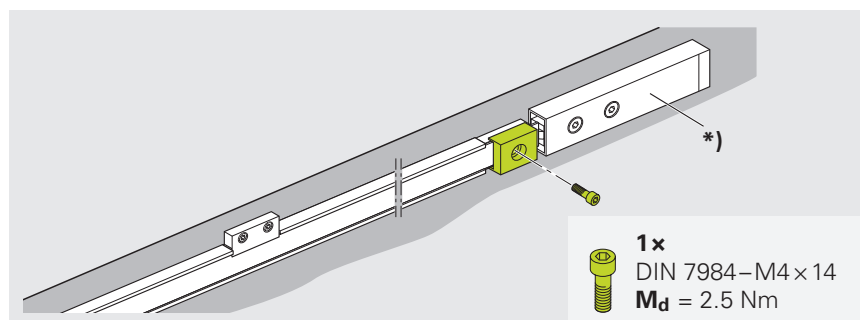

*) Tensioning device

Return to main menu

- ▶ Tap Home
- > The power supply of the encoder is disconnected.
- > The main menu is opened.

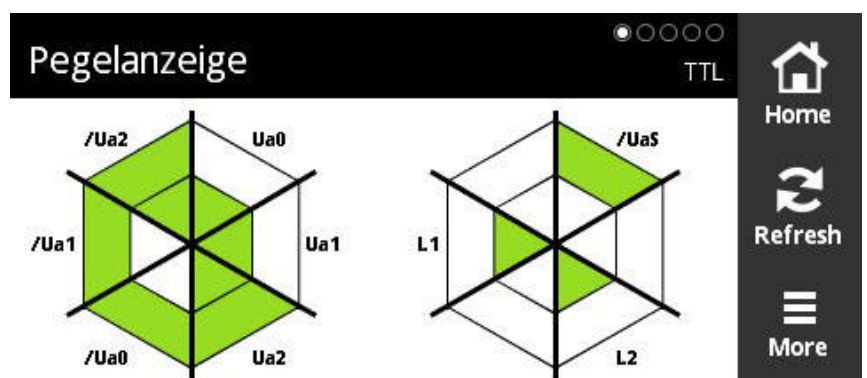

5.4.5 Activating the limit switches

Mounting the magnets for the limit switches

Using the magnets for the limit switches, you can detect the end positions.

Ensure that the magnets are oriented correctly.

T = carrier side

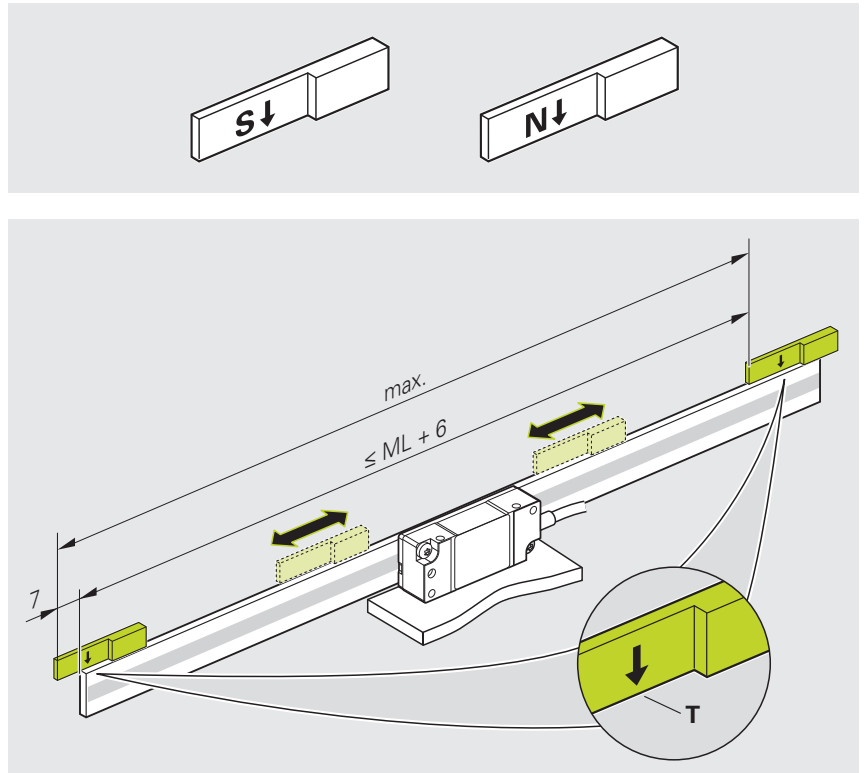

- ▶ Wipe to switch to the **Switching signals** screen

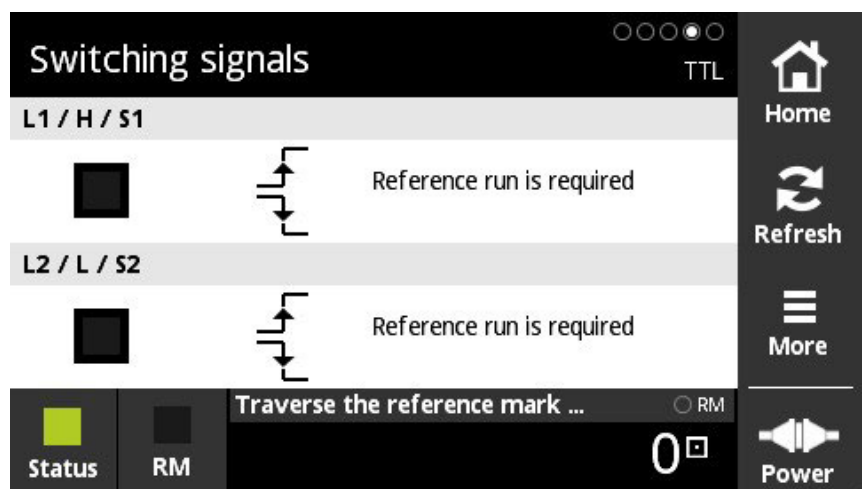

Switching signals screen

- ▶ Traverse the scanning head to the desired position
- ▶ Move the magnet until L1 or L2 shows a signal change
- ▶ Mark the position of the magnet
- ▶ Clean the mounting surface, if required
- ▶ Remove the protective film of the scale
- ▶ Attach the magnet

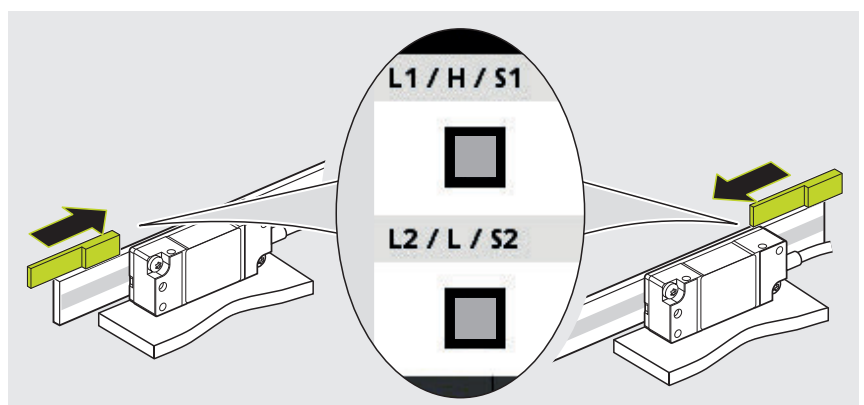



For more information, see the **Exposed Linear Encoders** brochure.

- ▶ www.heidenhain.com/documentation
- ▶ Enter the document ID **208960**



For more information, refer to the **Interfaces of HEIDENHAIN Encoders** brochure.

- ▶ www.heidenhain.com/documentation
- ▶ Enter the document ID **1078628**

Additional information on LIDA 47R

Using a Type S magnet, you can detect the reference mark position. Only one reference mark can be selected. The position of the reference mark can be selected every 50 mm.

The Type N magnets allow you to detect the limit positions.

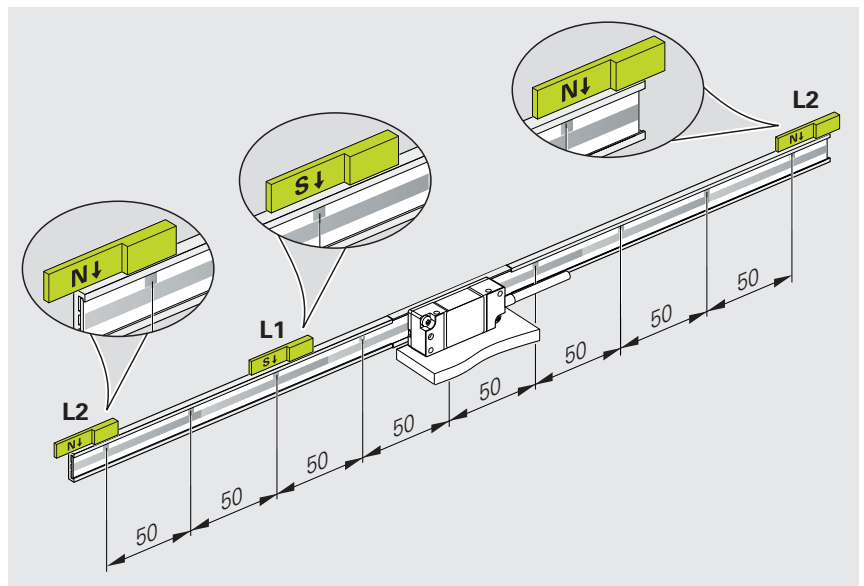

- ▶ Place the magnet arrow in the center of the reference mark

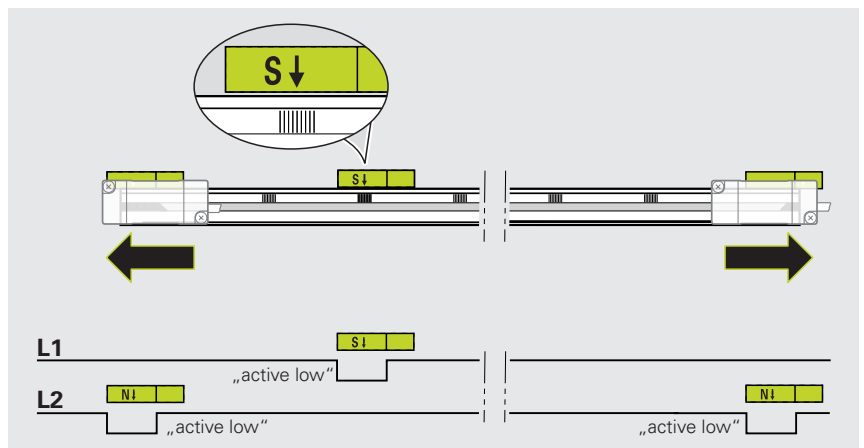

Next step: "Final steps", Page 67

5.5 Adjustment and diagnosis of LIDA 48

5.5.1 Connecting the encoder to the PWT

Connecting the encoder

NOTICE

Property damage due to electrical stress!

- ▶ Do not engage or disengage any connecting elements while the product is under power

- ▶ Connect the encoder to the PWT 101
- ▶ Connect the PWT 101 to the power supply

Selecting the connection

Connection options

Connecting the encoder automatically	Connecting the encoder manually
Recommended option with automatic determination of the measuring parameters. Page 54	Alternative option if the encoder cannot be connected automatically. Page 55

Connecting the encoder automatically

- ▶ Tap **Automatic Diagnosis** in the main menu
- > The **Automatic Diagnosis** is performed.
- > The **PWT display** screen is opened.

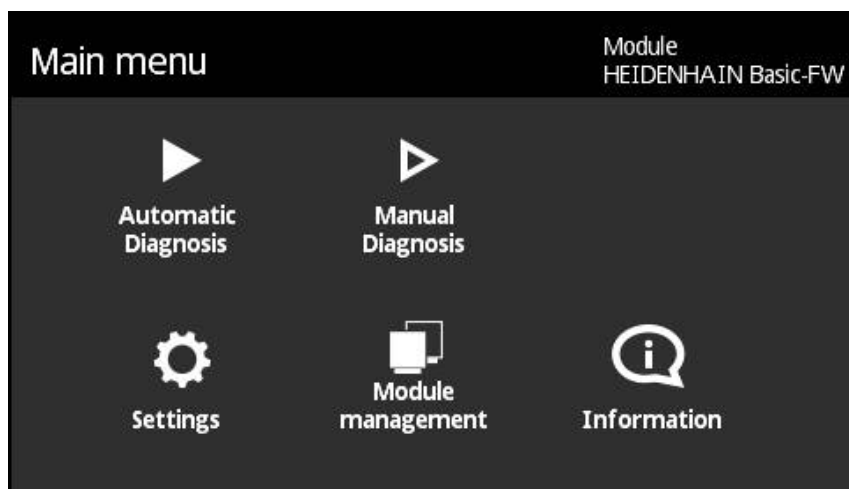

Main menu



If you cannot connect the encoder automatically, proceed as described in the **Connecting the encoder manually** chapter.

Next step: "Adjusting the scanning head", Page 57

Connecting the encoder manually

- ▶ Tap **Manual diagnostics** in the main menu
- ▶ The **Supply voltage of encoder** screen is opened.

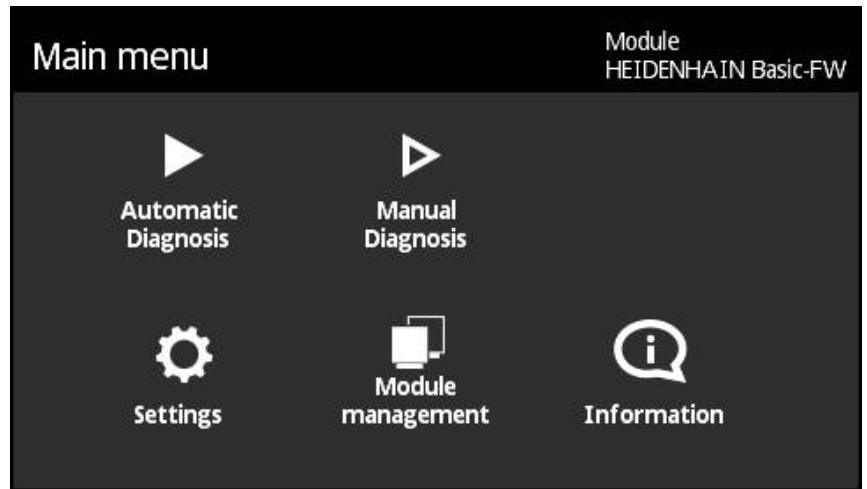

Main menu

- ▶ Select the supply voltage
- ▶ Activate the **Adjust supply voltage** checkbox, if required
- ▶ Swipe right to left
- ▶ The **Encoder interface** screen is opened.

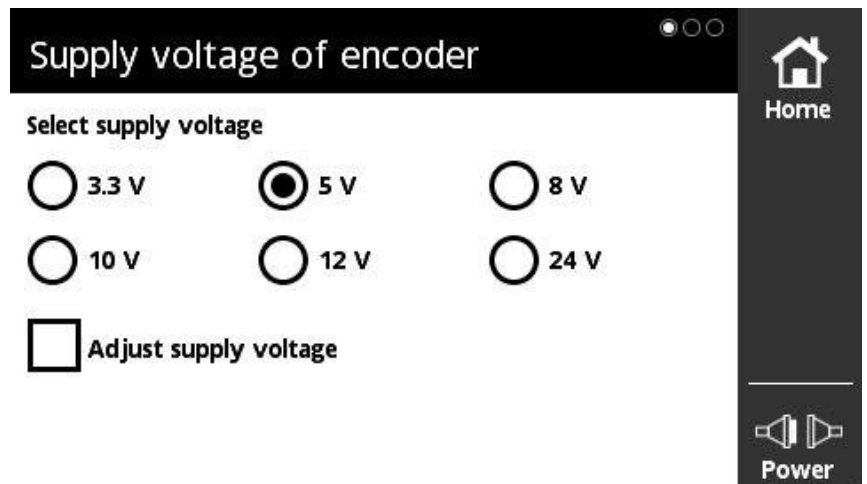

Supply voltage of encoder screen

- ▶ Select the encoder interface
- ▶ Swipe right to left
- ▶ The **Manual diagnostics** screen is opened.

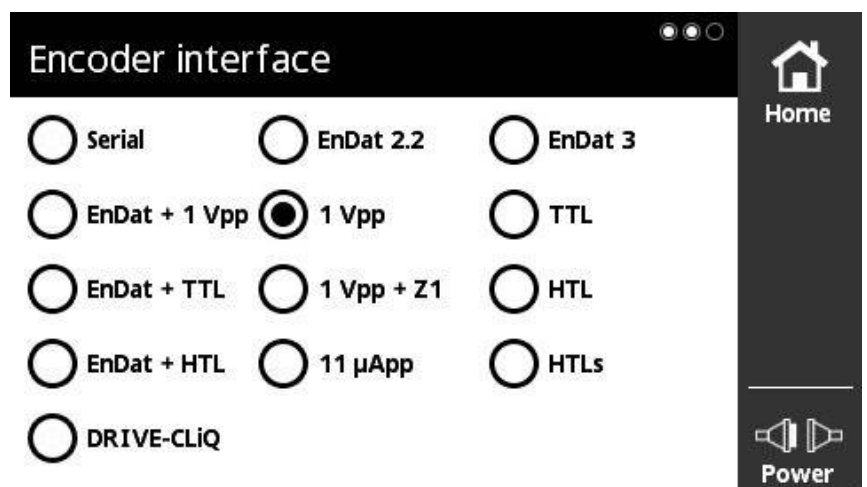

Encoder interface screen

- ▶ Check your selection
- ▶ Tap **Connect**
- > The connection to the encoder is established.
- > The **PWT display** screen is opened.

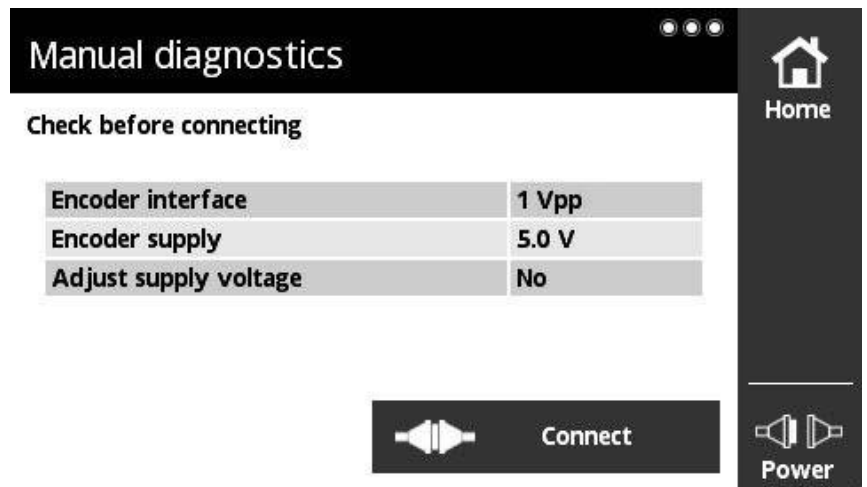

Manual Diagnosis screen

Next step: "Adjusting the scanning head", Page 57

5.5.2 Adjusting the scanning head

In the **PWT display** screen, you can evaluate the incremental and reference mark signals based on the bar diagrams.

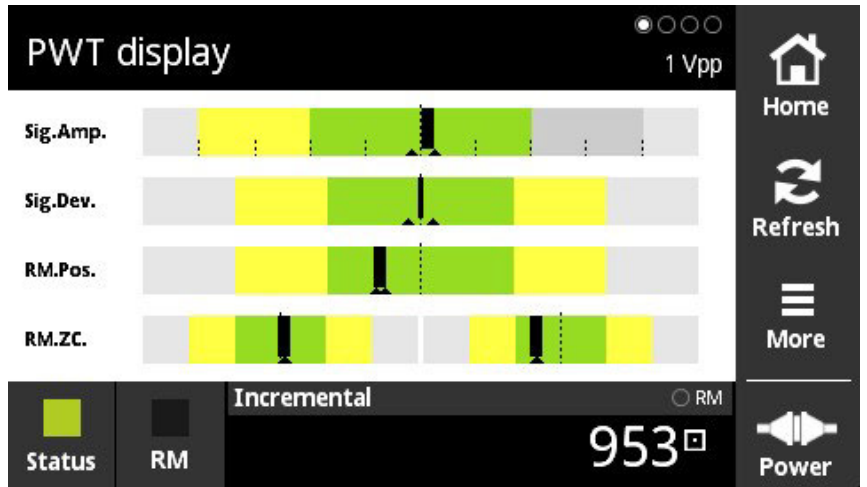

PWT display screen

i For the mounting variant with the holder on the side, the blind hole in the scanning head can be used for the adjustment.

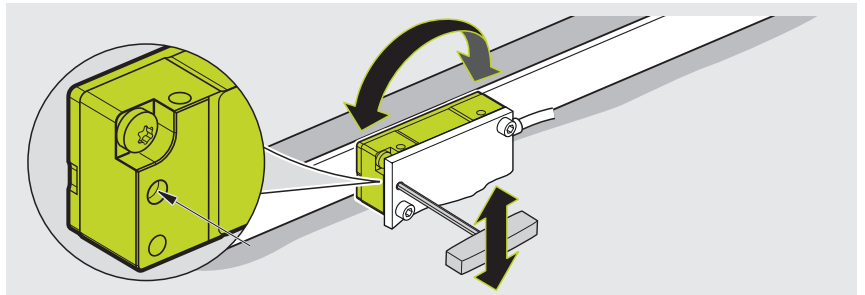

Setting the output signals

The black bar represents the current output signals.

- ▶ Rotate the scanning head to set the output signals to 1 V_{PP}

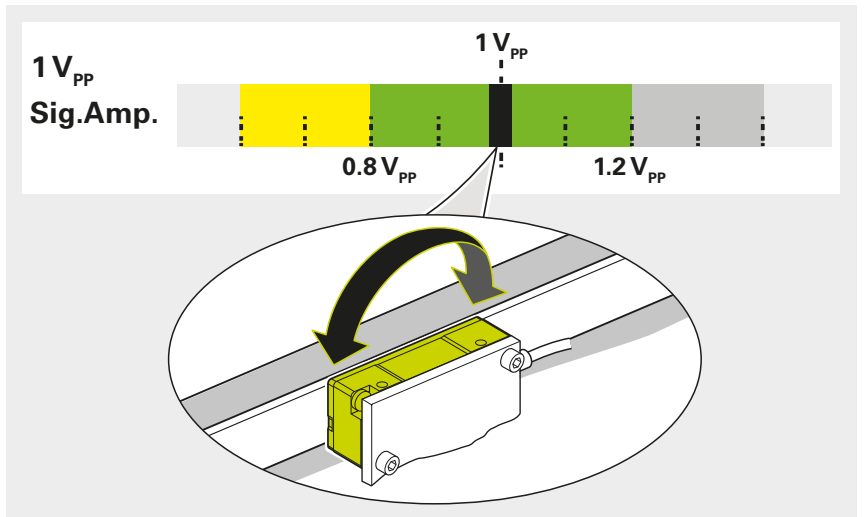

- ▶ Lightly tighten the screws

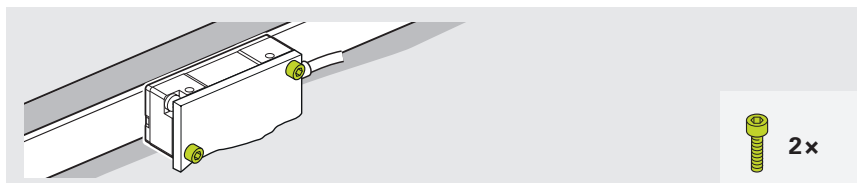

Set the reference mark signal

- ▶ Traverse the reference mark (R) with the scanning head

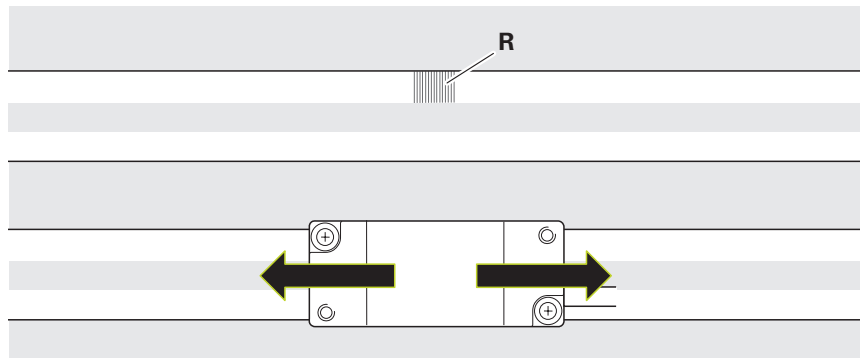

- ▶ Tap lightly to rotate the scanning head a minimum distance to set the optimal reference mark signals.

*) Green = good

**) Optimal

- ▶ Ensure that the incremental signals do not decrease

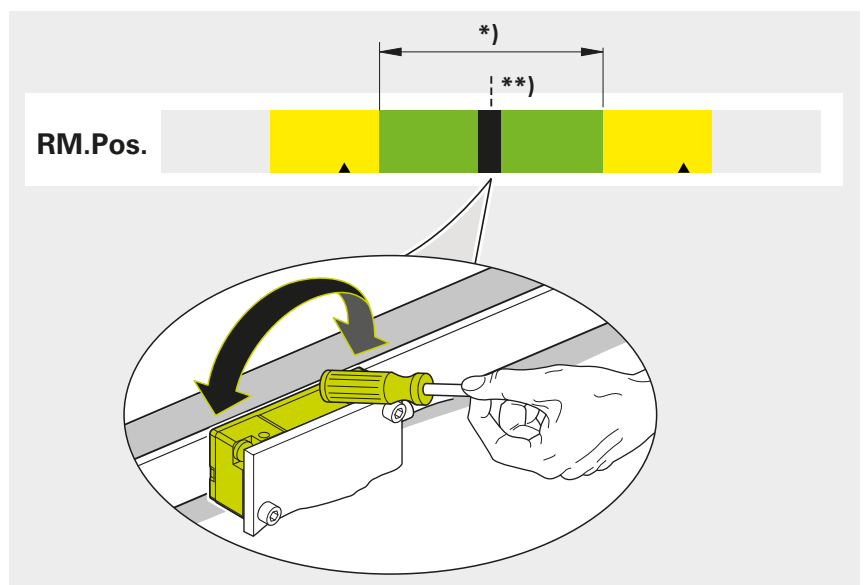

- ▶ Tighten the screws with the specified torque

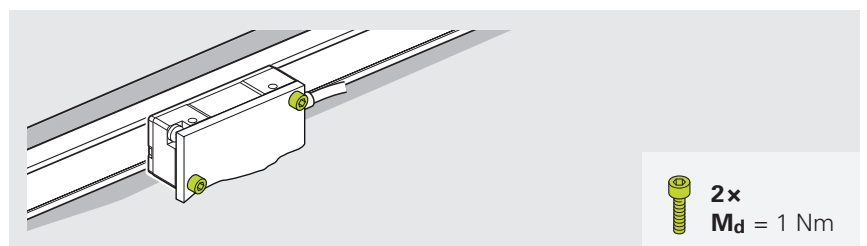

5.5.3 Checking the function indicator

The function indicator permits fast and easy signal-quality checks.

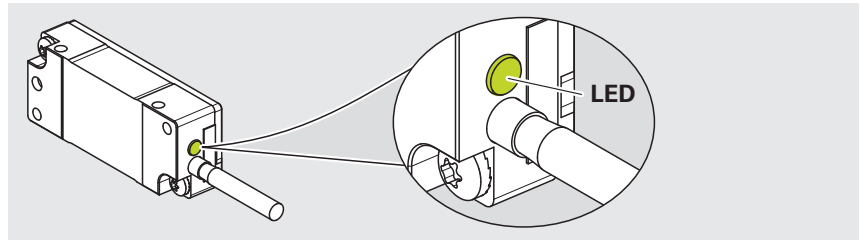

If the LED blinks green after adjustment, proceed as follows:

- ▶ Clean the measuring standard and the scanning window of the scanning head
- ▶ Check the mounting tolerance
- ▶ Repeat adjustment

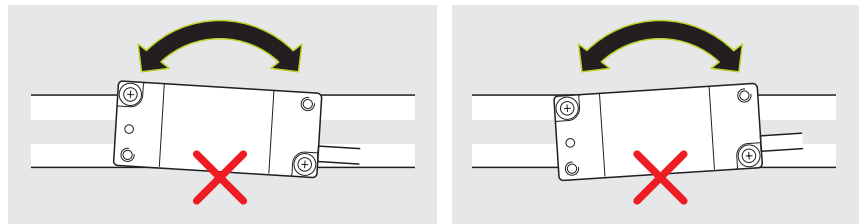

LED blinks

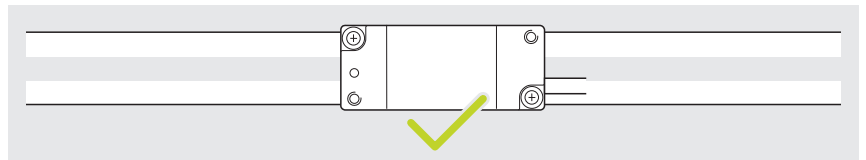

LED shines green



For more information, see the **Exposed Linear Encoders** brochure.

- ▶ www.heidenhain.com/documentation
- ▶ Enter the document ID **208960**

5.5.4 Tensioning the scale tape

Use the PWT 101 testing device to tension the scale tape.

Tensioning the scale tape

- ▶ Tap **Automatic Diagnosis** in the main menu
- > The **Automatic Diagnosis** is performed.
- > The **PWT display** screen is opened.

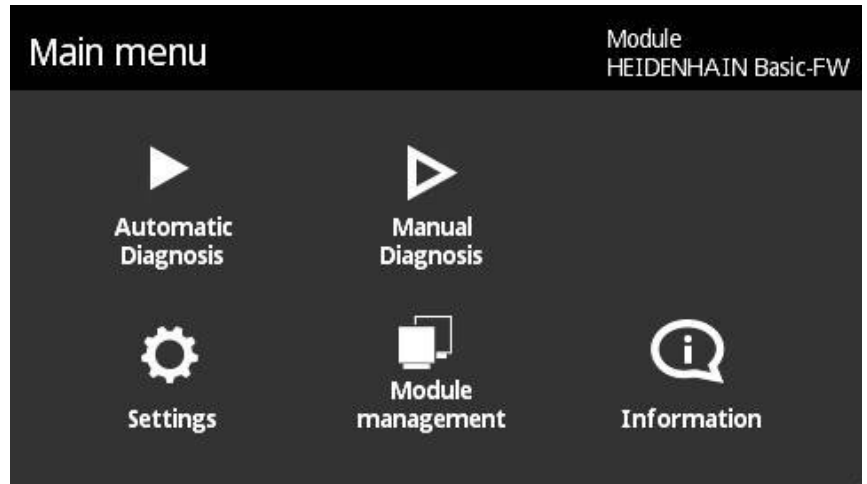

Main menu

- ▶ Tap **More**
- > The **More** menu is opened.
- ▶ Tap **Units**
- > The **Display settings** screen is opened.

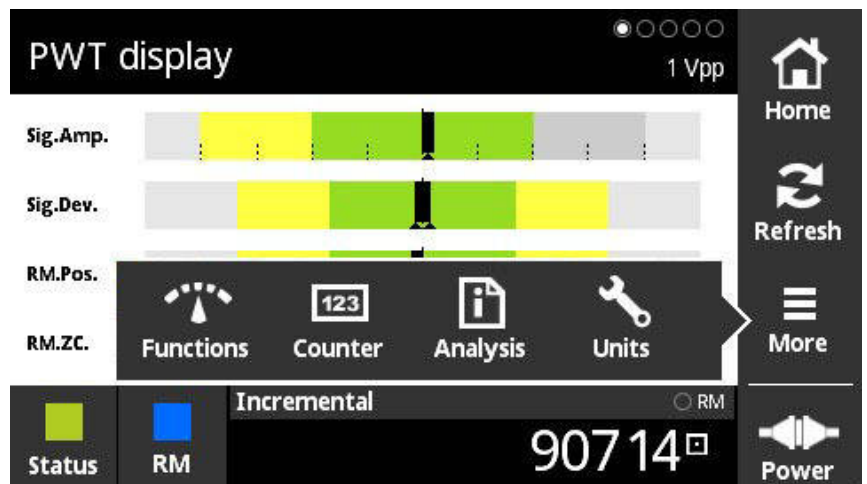

PWT display screen > More menu

- ▶ Tap the **Linear** option
- ▶ Enter 20 μm in the **Signal period** input field
- ▶ Tap **Back**
- > The **PWT display** screen is opened.

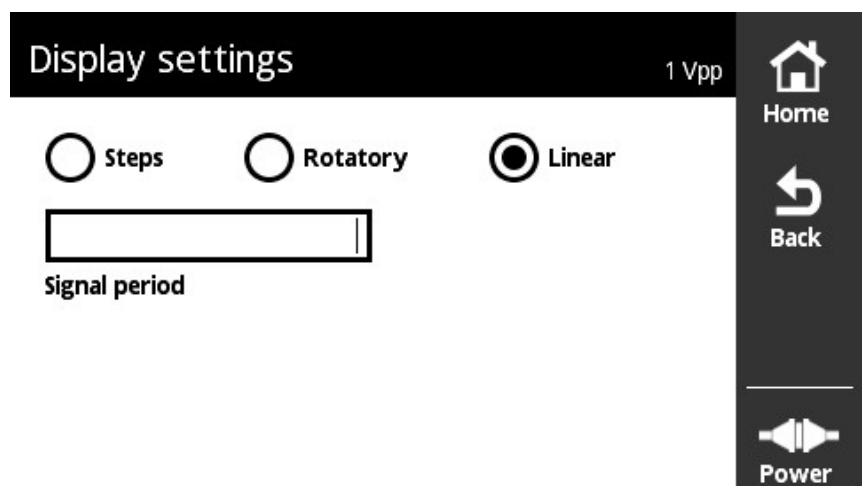

Display settings screen

- ▶ Push the scanning head in the direction of the tensioning device up to the end of the measuring length

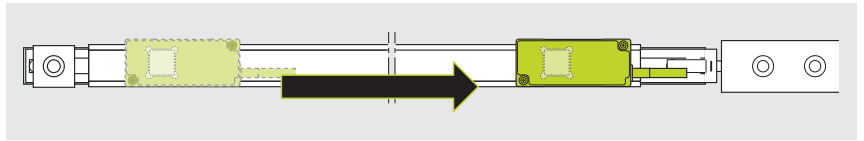

i The values stated here are exemplary values.
 ▶ Replace the stated values with customer-specific parameters

- ▶ Measure the distance (X_v) between the center of the mounting block and the center of the scanning window and note it down

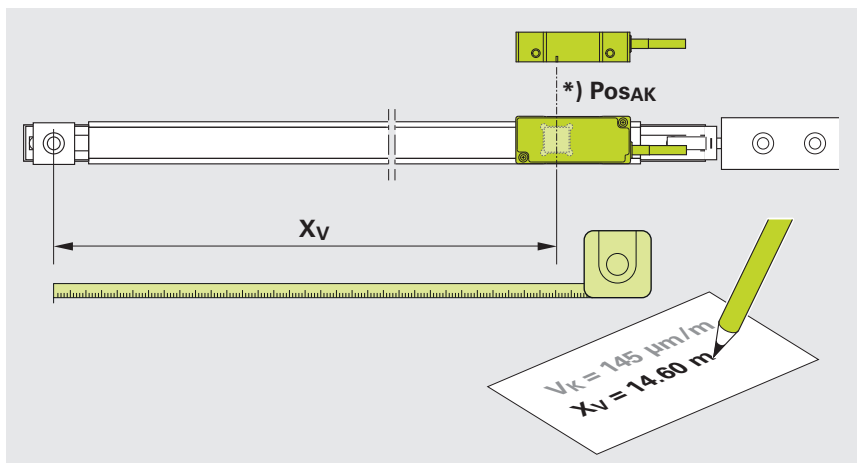

*) POS_{AK} = Position of scanning head

- ▶ Tap **More**
- ▶ The **More** menu is opened.
- ▶ Tap **Counter**
- ▶ The **Display options for count value** screen is opened.

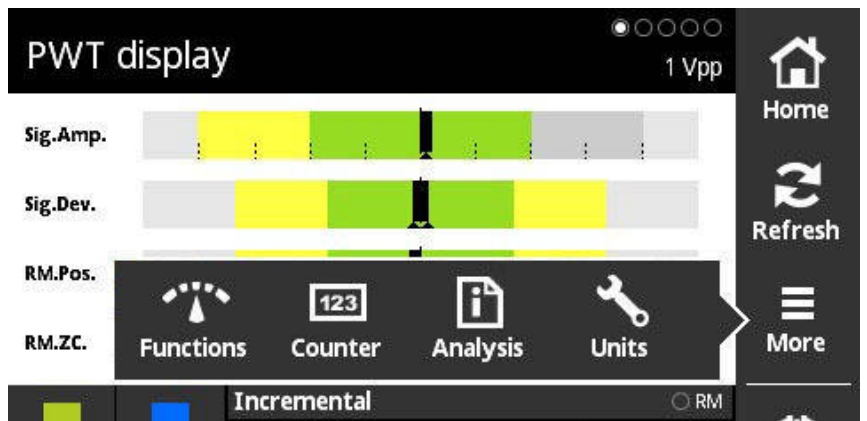

PWT display screen > More menu

- ▶ Tap the **Manual** option for the **Set the count value:** parameter
- ▶ Enter the value 0 in the **Position [µm]** input field (zeroing)
- ▶ Tap **Back**
- ▶ The **PWT display** screen is opened.

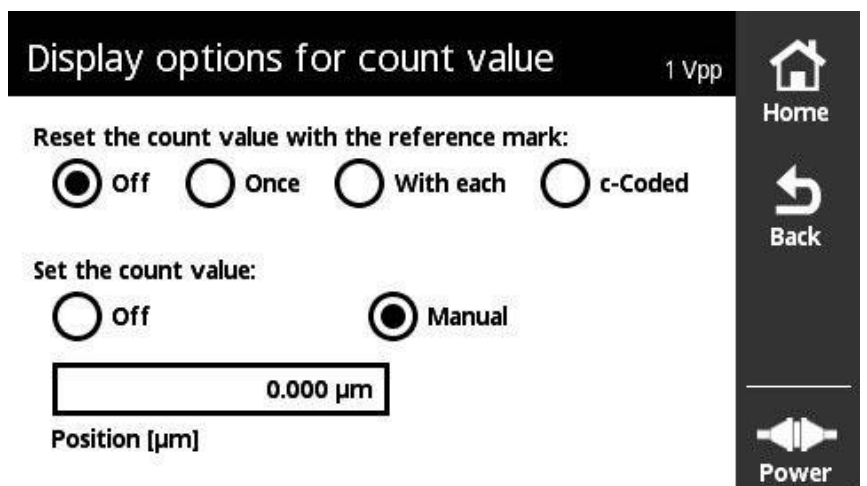

Display options for count value screen

- ▶ Tension the scale tape by 50 μm
- ▶ Remove the tension from the scale tape

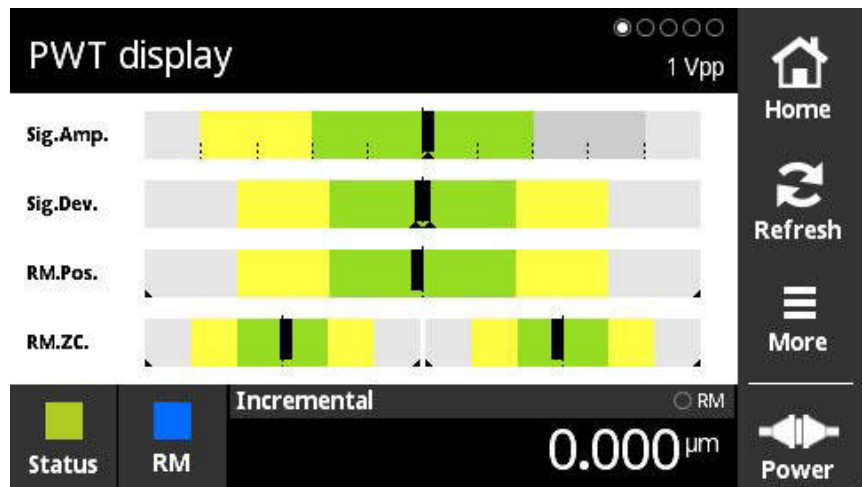

PWT display screen

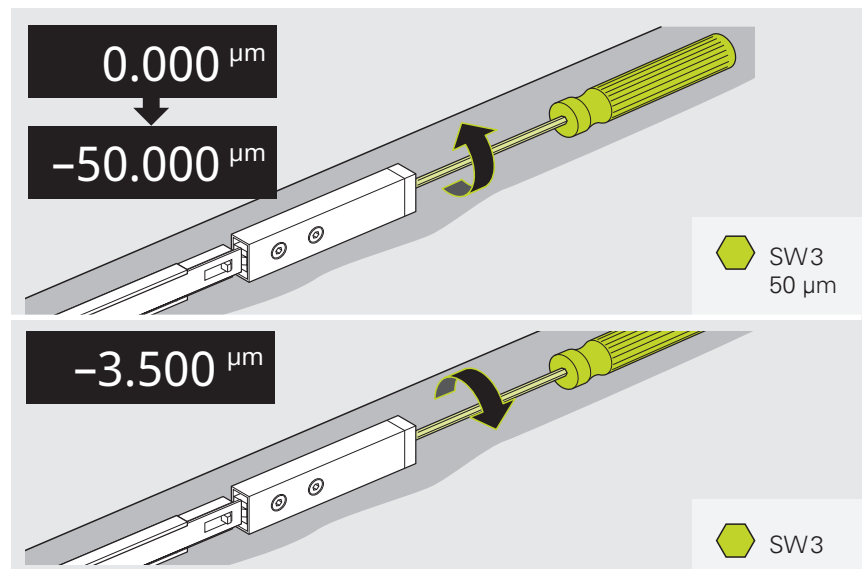

- ▶ Tap **More**
- ▶ The **More** menu is opened.
- ▶ Tap **Counter**
- ▶ The **Display options for count value** screen is opened.

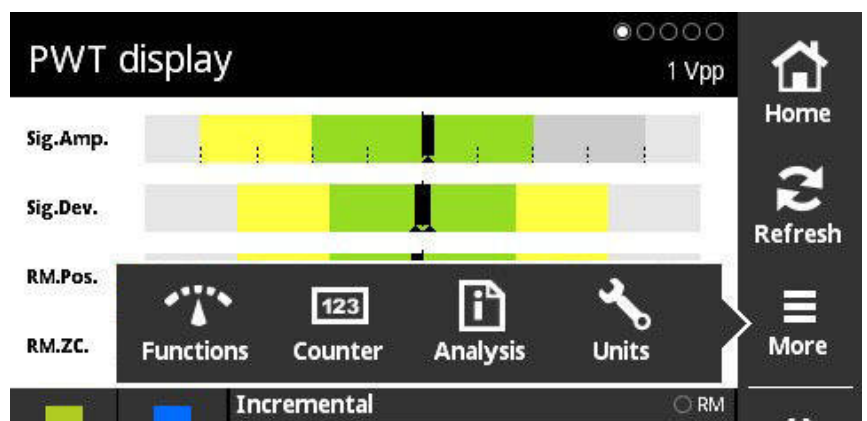

PWT display screen > More menu

- ▶ Tap the **Manual** option for the **Set the count value:** parameter
- ▶ Enter the value 0 in the **Position [μm]** input field (zeroing)
- ▶ Tap **Back**
- ▶ The **PWT display** screen is opened.

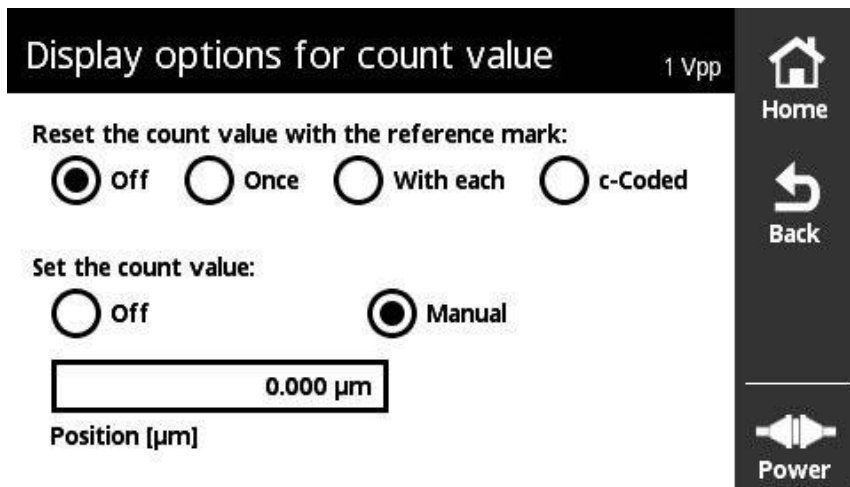

Display options for count value screen

- ▶ Calculate the tensioning value **A**

i V_K = Previously noted-down shortening factor of the scale tape being used

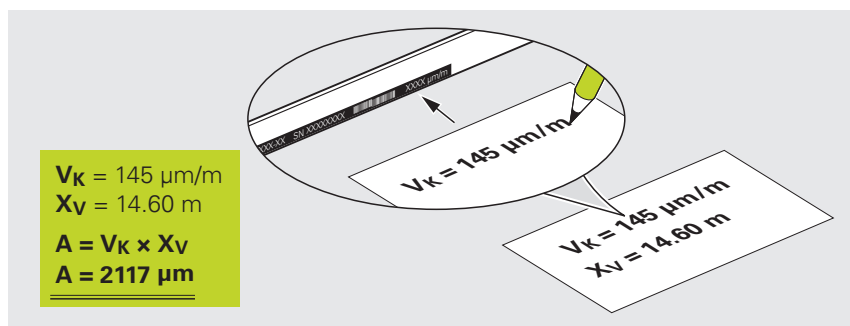

Calculation example

- ▶ Tension the scale tape until the calculated tensioning value has been reached

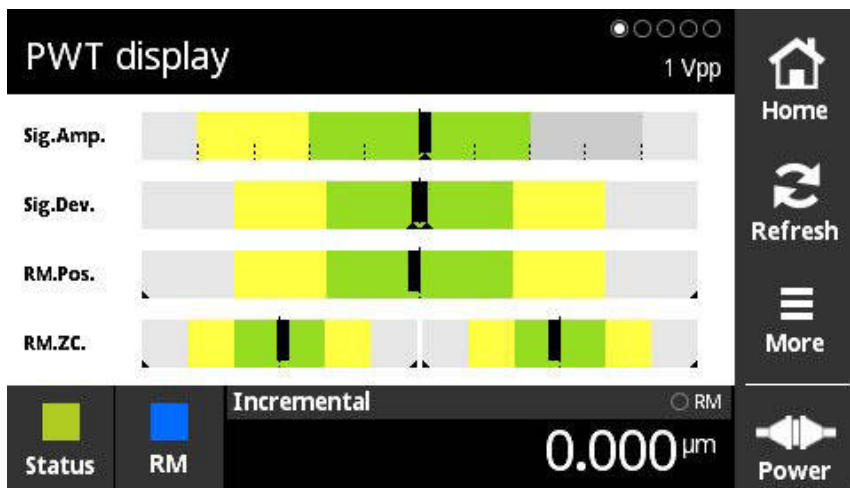

PWT display screen

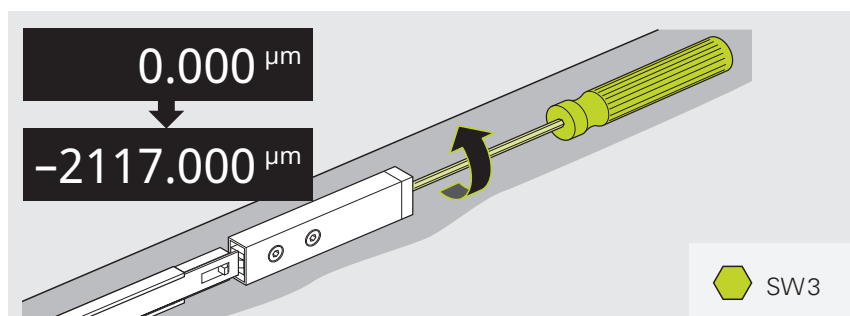

- ▶ Lightly tap the scale-tape carrier sections to release any tension
- ▶ Check the tensioning value
- ▶ If the clamping value differs from the calculated clamping value, re-tension the scale tape

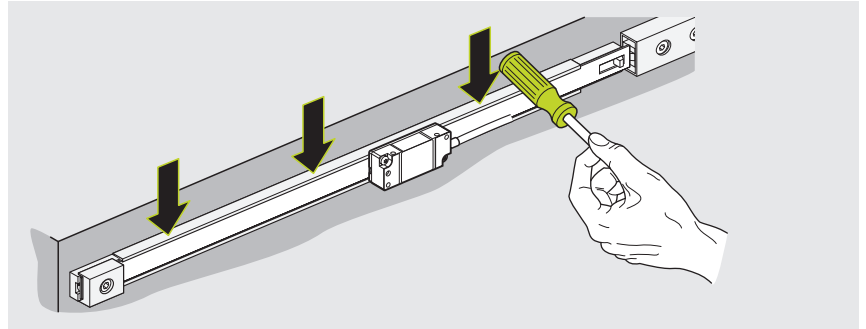

- ▶ If a fixing clamp (**Z**) is needed, fasten it with the specified torque

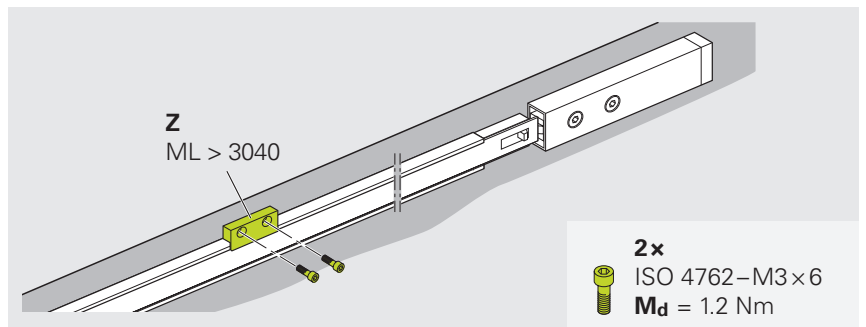

- ▶ Fasten the mounting block with the specified torque



You can leave the tensioning device mounted, or you can remove it.

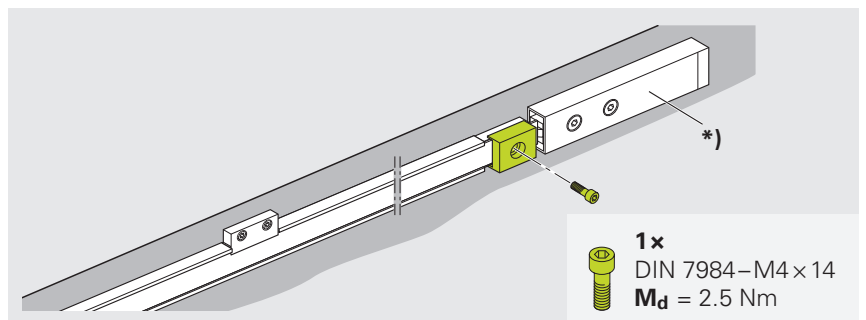

*) Tensioning device

Return to main menu

- ▶ Tap Home
- > The power supply of the encoder is disconnected.
- > The main menu is opened.

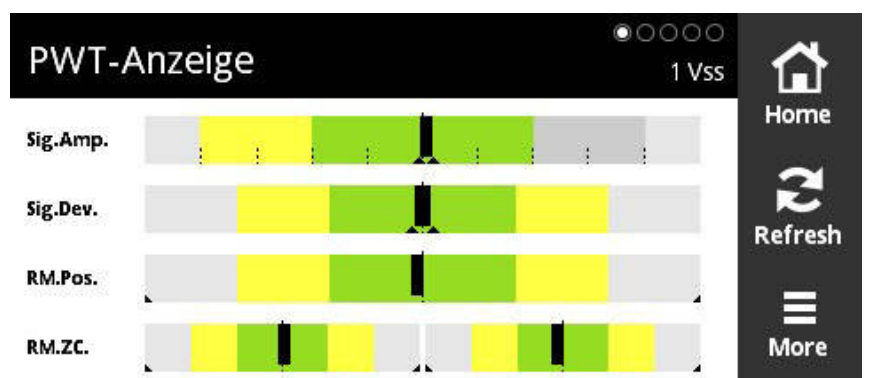

5.5.5 Activating the limit switches

Mounting the magnets for the limit switches

Using the magnets for the limit switches, you can detect the end positions.

Ensure that the magnets are oriented correctly.

T = carrier side

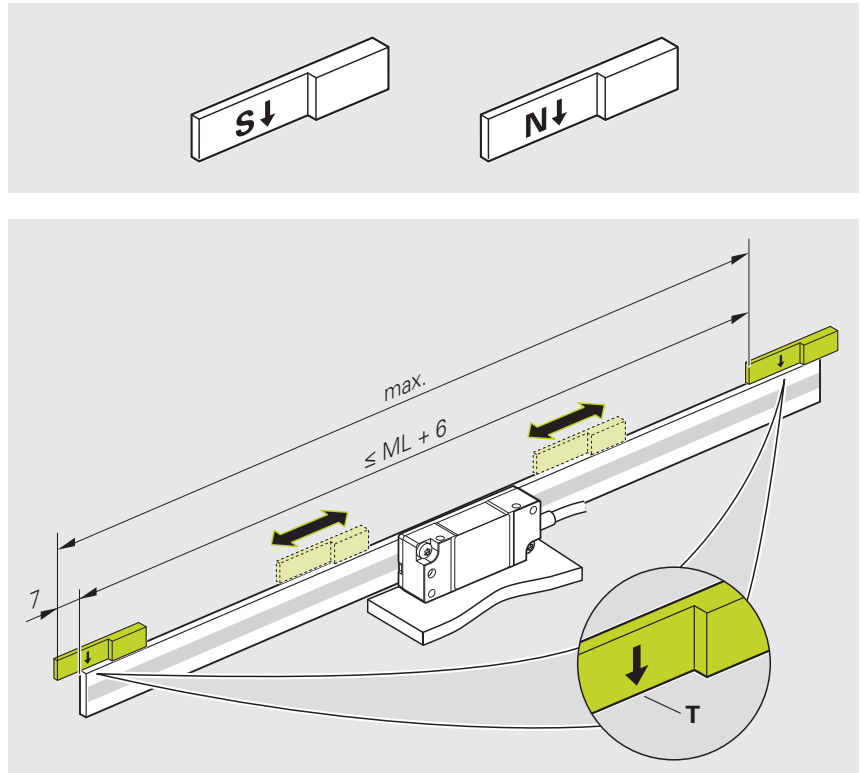

- ▶ Wipe to switch to the **Switching signals** screen

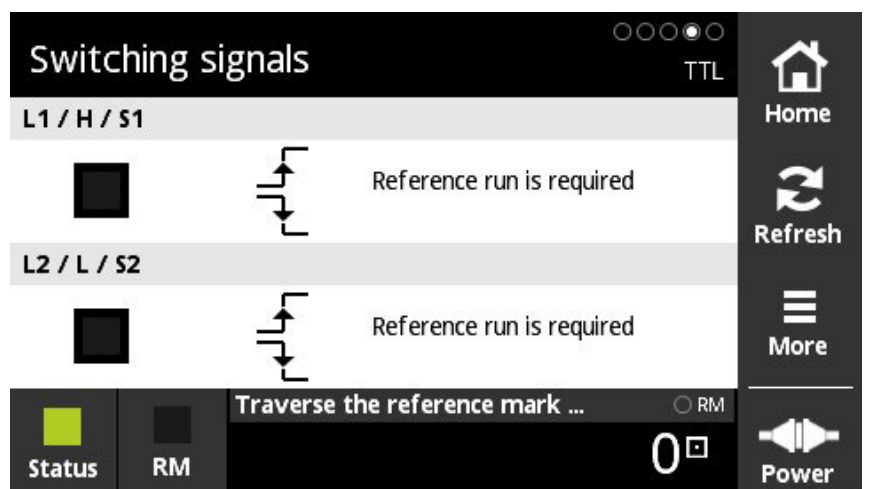

Switching signals screen

- ▶ Traverse the scanning head to the desired position
- ▶ Move the magnet until L1 or L2 shows a signal change
- ▶ Mark the position of the magnet
- ▶ Clean the mounting surface, if required
- ▶ Remove the protective film of the scale
- ▶ Attach the magnet

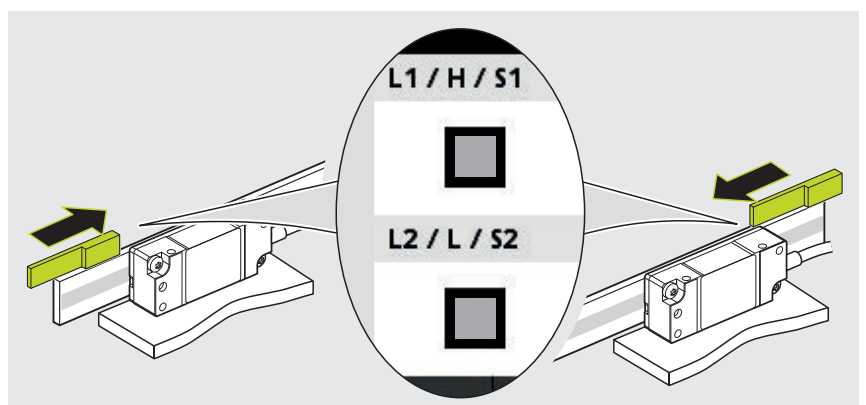



For more information, see the **Exposed Linear Encoders** brochure.

- ▶ www.heidenhain.com/documentation
- ▶ Enter the document ID **208960**



For more information, refer to the **Interfaces of HEIDENHAIN Encoders** brochure.

- ▶ www.heidenhain.com/documentation
- ▶ Enter the document ID **1078628**

Additional information on LIDA 48R

Using a Type S magnet, you can detect the reference mark position. Only one reference mark can be selected. The position of the reference mark can be selected every 50 mm.

The Type N magnets allow you to detect the limit positions.

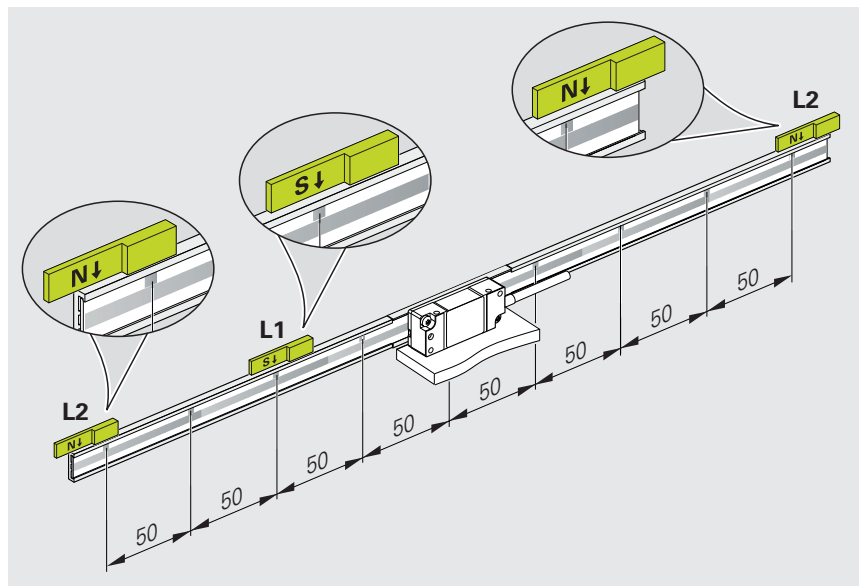

- ▶ Place the magnet arrow in the center of the reference mark

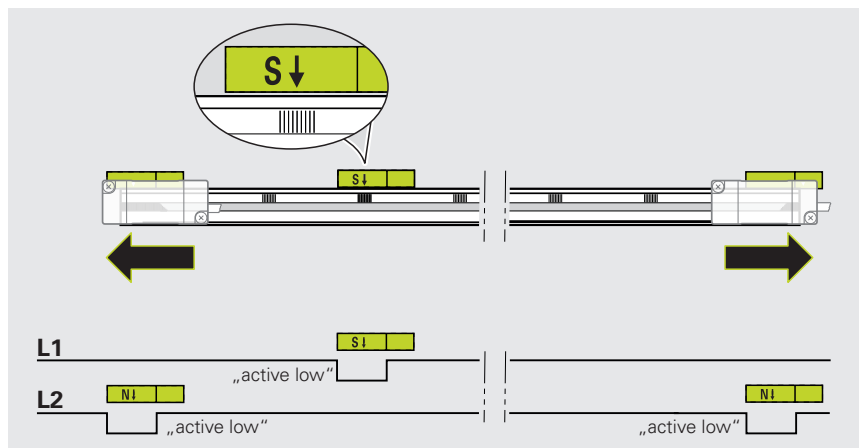

Next step: "Final steps", Page 67

6 Final steps

6.1 Connecting the encoder to the downstream electronics

WARNING

Danger of electric shock due to plug connections under voltage!

Connecting and disconnecting live cables and plug connections in the equipment can result in death or serious injury.

- Only connect and disconnect cables and plug connections when no current is flowing through them
- Disconnect the downstream electronics from power before connecting the product
- For cables without connectors, pay attention to the pin layout

- ▶ Connect the encoder to the downstream electronics

NOTICE

Property damage resulting from incorrect routing of the connecting cable!

Connecting cables may become damaged as a result of incorrect routing.

- ▶ Observe the maximum permissible bend radii
- ▶ Do not cross connecting cables in drag chains
- ▶ Route connecting cables professionally



For more information on the cable characteristics and cable routing, refer to the **Cables and Connectors** brochure.

- ▶ www.heidenhain.com/documentation
- ▶ Enter the document ID **1206103**



For more information on the pin layouts of pre-assembled cables, refer to the **Cables and Connectors** brochure.

- ▶ www.heidenhain.com/documentation
- ▶ Enter the document ID **1206103**



For more information on sources of interference, refer to the **Interfaces of HEIDENHAIN Encoders** brochure.

- ▶ www.heidenhain.com/documentation
- ▶ Enter the document ID **1078628**

7 Removal

This chapter describes the disassembly of the product.

7.1 Safety precautions regarding removal

WARNING

Live plug connections!

If you disengage plug connections while the equipment is under power, this may result in fatal accidents or severe personal injury.

- ▶ Do not engage or disengage any connecting elements while the product is under power

WARNING

Moving machine parts!

Risk of injury due to moving machine parts depending on the installation location and the application

- ▶ Observe all of the machine manufacturer's notes on working on the machine (e.g., always disconnect the machine from the power supply)

CAUTION

Fragile carrier material of the graduation!

Risk of injury from splinters and sharp edges of the carrier material

- ▶ Wear protective gloves and safety goggles
- ▶ Do not bend or deform the measuring standard excessively

7.2 Removing the scanning head

- ▶ Remove the scanning head in the reversed sequence of mounting.
Further information: "Mounting the scanning head", Page 28

7.3 Disassembling the parts kit



Further information can be found in the **Disassembly Instructions**.

- ▶ www.heidenhain.com/documentation
- ▶ Enter the document ID **1185755**

HEIDENHAIN

DR. JOHANNES HEIDENHAIN GmbH

Dr.-Johannes-Heidenhain-Straße 5

83301 Traunreut, Germany

☎ +49 8669 31-0

☎ +49 8669 32-5061

info@heidenhain.de

Technical support ☎ +49 8669 32-1000

Measuring systems ☎ +49 8669 31-3104

service.ms-support@heidenhain.de

NC support ☎ +49 8669 31-3101

service.nc-support@heidenhain.de

NC programming ☎ +49 8669 31-3103

service.nc-pgm@heidenhain.de

PLC programming ☎ +49 8669 31-3102

service.plc@heidenhain.de

APP programming ☎ +49 8669 31-3106

service.app@heidenhain.de

www.heidenhain.com