

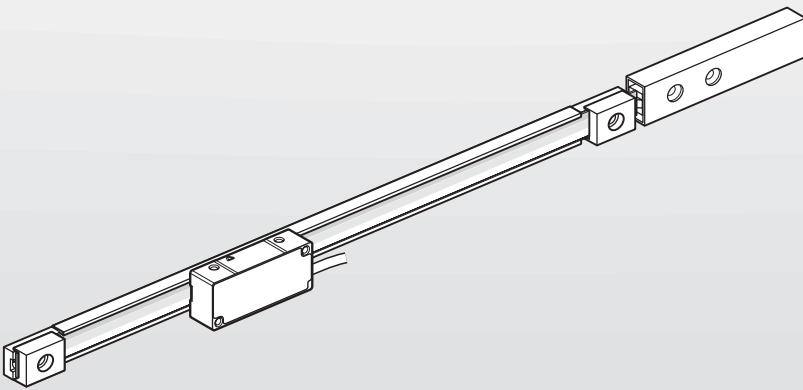

HEIDENHAIN



LIC 4115
LIC 4135
LIC 4195

Mounting Instructions

Table of contents

1	Basic information.....	4
1.1	Validity of the documentation.....	4
1.2	Target groups of the Mounting Instructions.....	4
1.3	Notes on reading the documentation.....	5
1.4	Symbols and fonts used for marking text.....	6
1.5	Notes in this documentation.....	7
1.6	Units and tolerances.....	7
2	Safety.....	8
2.1	Personnel qualification.....	8
2.2	General safety precautions.....	8
3	Items supplied and accessories.....	10
3.1	Items supplied.....	10
3.1.1	Items supplied: LIC 4005 parts kit.....	10
3.1.2	Items supplied: LIC 4005 scale-tape carrier section.....	10
3.1.3	Items supplied: LIC 411, LIC 413, LIC 419 scanning head.....	12
3.2	Mounting accessories.....	13
3.2.1	Accessories for mounting the parts kit.....	13
3.2.2	Accessories for mounting the scanning head.....	13
4	Mounting.....	14
4.1	Requirements and notes.....	14
4.2	Mounting the parts kit.....	15
4.2.1	Choosing the mounting variant.....	15
4.2.2	Variant: Mounting with adhesive film.....	16
4.2.3	Variant: Mounting with screws.....	22
4.3	Mounting the scanning head.....	27
4.3.1	Choosing the mounting variant.....	27
4.3.2	Variant: Mounting with the holder on the side.....	28
4.3.3	Variant: Mounting with the holder at top.....	32
4.3.4	Variant: Mounting with the holder at bottom.....	36

5	Adjustment and diagnosis.....	40
5.1	Requirements and notes.....	40
5.2	Continuity check.....	40
	5.2.1 Measuring the electrical resistance.....	40
5.3	Connecting the encoder to the ATS.....	41
	5.3.1 Connecting the encoder.....	41
	5.3.2 Selecting the connection.....	41
	5.3.3 Connecting the encoder using its ID.....	42
	5.3.4 Connecting the encoder manually.....	43
5.4	Mounting the scanning head.....	46
	5.4.1 Selecting the scanning head.....	46
	5.4.2 Mounting the LIC 411 or LIC 419x scanning head.....	47
	5.4.3 Mounting the LIC 413 scanning head.....	49
	5.4.4 Mounting the LIC 413 scanning head in bus operation.....	52
6	Final steps.....	55
6.1	Tensioning the scale tape.....	55
	6.1.1 Tensioning the scale tape by using the Clamp material measure menu item.....	56
	6.1.2 Tensioning the scale tape by using the Position display menu item.....	60
6.2	Connecting the encoder with the downstream electronics.....	63
7	Removal.....	64
7.1	Safety precautions regarding removal.....	64
7.2	Removing the scanning head.....	64
7.3	Disassembling the parts kit.....	64

1 Basic information

This chapter contains information about the product and the Mounting Instructions.

1.1 Validity of the documentation

These Mounting Instructions apply to LIC 4115, LIC 4135, LIC 4195.

- Before using the documentation, check whether the documentation and product model match. The designation of the product is printed on the ID label.

ID label

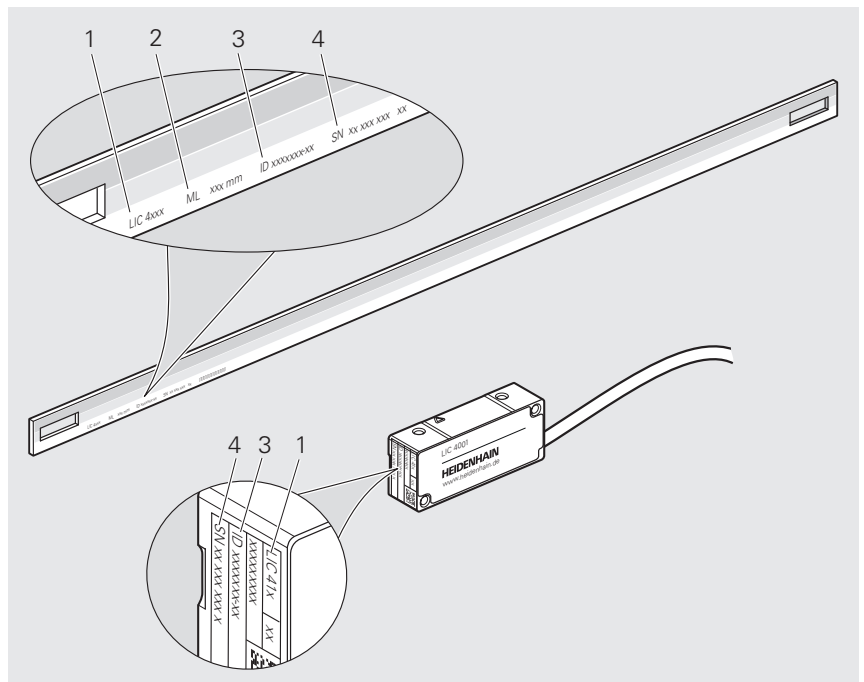

ID label with legend

- 1 Product name
- 2 Measuring length (ML)
- 3 Product ID/ Part number (ID)
- 4 Serial number (SN)

1.2 Target groups of the Mounting Instructions

The Mounting Instructions must be read and observed by every person who performs any of the following tasks:

- Design
- Mounting
- Removal

1.3 Notes on reading the documentation

WARNING

Fatal accidents, personal injury or property damage caused by non-compliance with the documentation!

Failure to comply with the documentation may result in fatal accidents, personal injury or property damage.

- ▶ Read the documentation carefully from beginning to end
- ▶ Keep the documentation for future reference

The following table lists the various parts of the documentation in their order of reading priority.

Document type	Description
Addendum	An Addendum supplements or supersedes the corresponding contents of the Operating Instructions and, if applicable, of the Mounting Instructions. If an Addendum is included in the shipment, it has the highest priority for reading. All other documentation content retains its validity.
Operating Instructions	The Operating Instructions contain all of the information and safety instructions for the proper and intended operation of the device. The Operating Instructions (English language version) are included in delivery and can also be downloaded in other languages from www.heidenhain.com/documentation . The Operating Instructions must be read prior to initial operation of the product. The Operating Instructions have the second highest priority for reading.
Mounting Instructions	The Mounting Instructions contain all the information and safety precautions needed for the proper mounting and installation of a product. The Mounting Instructions are not included in delivery and must be downloaded from www.heidenhain.com/documentation . The Mounting Instructions have the third highest priority for reading.

Have you found any errors or would you like to suggest changes?

We are continuously striving to improve our documentation for you. Please help us by sending your suggestions to the following e-mail address:

userdoc@heidenhain.de

1.4 Symbols and fonts used for marking text

In these instructions the following symbols and fonts are used for marking text:

Format	Meaning
▶ ...	Identifies an action and the result of this action
> ...	Example: ▶ Tilt the shipping brace to remove it (c) > The shipping brace has been removed now
■ ...	Identifies an item of a list
■ ...	Example: ■ Solid contaminants: class 3 ■ Max. pressure dew point: class 4
Bold	Identifies elements in figures and illustrations, such as positions, dimensions and worksteps Example: S marks the beginning of the measuring length (ML) .

1.5 Notes in this documentation

Safety precautions

Precautionary statements warn of hazards in handling the product and provide information on their prevention. Precautionary statements are classified by hazard severity and divided into the following groups:

DANGER

Danger indicates hazards for persons. If you do not follow the avoidance instructions, the hazard **will result in death or severe injury**.

WARNING

Warning indicates hazards for persons. If you do not follow the avoidance instructions, the hazard **could result in death or serious injury**.

CAUTION

Caution indicates hazards for persons. If you do not follow the avoidance instructions, the hazard **could result in minor or moderate injury**.

NOTICE

Notice indicates danger to material or data. If you do not follow the avoidance instructions, the hazard **could result in property damage**.

Informational notes

Informational notes ensure reliable and efficient operation of the product. Informational notes are divided into the following groups:



The information symbol indicates a **tip**.
A tip provides important additional or supplementary information.



The book symbol indicates a **cross reference**.
A cross reference leads to external documentation, for example: further documentation from HEIDENHAIN or another supplier.

1.6 Units and tolerances

Unless otherwise specified, the dimensions stated in these Mounting Instructions are given in millimeters.

Unless otherwise specified, the tolerances stated in these Mounting Instructions conform to ISO 8015 and ISO 2768 standards.

mm

 Tolerancing ISO 8015
 ISO 2768:1989-mH
 $\leq 6 \text{ mm: } \pm 0.2 \text{ mm}$

2 Safety

This chapter provides important safety information needed for the proper mounting and installation of the product.

2.1 Personnel qualification

Mounting, initial configuration and removal must be conducted by a qualified specialist under compliance with local safety regulations.

2.2 General safety precautions

WARNING

Danger of electric shock due to connection to unsuitable downstream electronics!

If you connect unsuitable downstream electronics to the product, fatal accidents or severe personal injuries can occur.

- ▶ Connect the product only to downstream electronics whose supply voltage comes from PELV systems

WARNING

Live plug connections!

If you disengage plug connections while the equipment is under power, this may result in fatal accidents or severe personal injury.

- ▶ Do not engage or disengage any connecting elements while the product is under power

WARNING

Risk of injury from damaged or worn components!

Safety functions can fail if damaged or worn components are installed. Failed safety functions can result in death or serious injury.

- ▶ Inspect the component for damage.
- ▶ Do not use any damaged or worn components
- ▶ In case of replacement, repair the thread
- ▶ Use new screws, spring pins and nuts
- ▶ Secure screws and nuts with suitable material-bonding anti-rotation lock

NOTICE

Property damage due to mechanical stress!

- ▶ Do not drop the product or subject it to major vibration
- ▶ Do not expose the product to mechanical stress
- ▶ Do not change the physical structure of the product

NOTICE**Property damage due to electrical stress!**

- ▶ Do not engage or disengage any connecting elements while the product is under power
- ▶ Do not touch the contacts of the plug connections

NOTICE**Electrostatic discharge (ESD)!**

This product contains electrostatically sensitive components that can be destroyed by electrostatic discharge (ESD).



- ▶ It is essential to observe the safety precautions for handling ESD-sensitive components
- ▶ Never touch connector pins without ensuring proper grounding
- ▶ Wear a grounded ESD wristband when handling the connections of the product

3 Items supplied and accessories

This chapter contains information on the items supplied and the available accessories of the product.

3.1 Items supplied

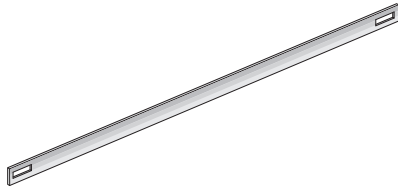
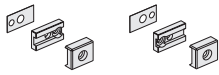
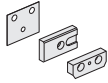
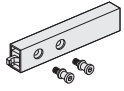
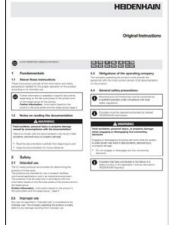
3.1.1 Items supplied: LIC 4005 parts kit

Component	Figure
Scale tape	
Shims, spacers, and mounting blocks	
Shim (U), holder and fixing clamp (Z) *	
Tensioning device with screws	
Operating Instructions	
Quality Inspection Document	

3.1.2 Items supplied: LIC 4005 scale-tape carrier section

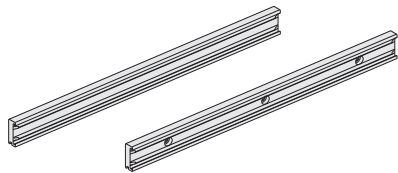
Component	Figure
Scale-tape carrier section (T) * for mounting with adhesive film or for mounting with screws	

* The number of required components depends on the measuring length (ML).

Number of components required for mounting with adhesive film

ML	T1970 / U / Z
≤ 3040	0 x
≤ 5040	1 x
≤ 7040	2 x
≤ 9040	3 x
≤ 11 040	4 x
.	.
.	.
≤ 30 040	14 x

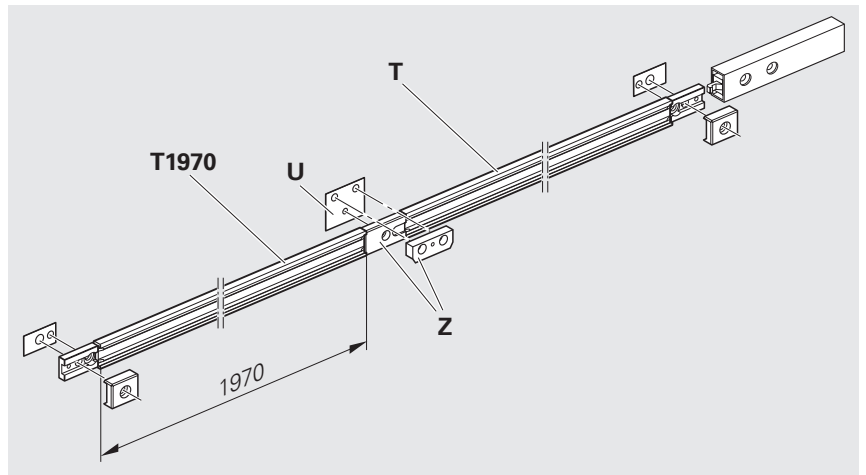

T1970 = Scale-tape carrier section with a length of 1970 mm

T = Remaining length of scale-tape carrier section

U = Shim for holder

Z = Holder with fixing clamp

Number of components required for mounting with screws

ML	T1970 / Z
≤ 3040	0 x
≤ 5040	1 x
≤ 7040	2 x
≤ 9040	3 x
≤ 11 040	4 x
.	.
.	.
≤ 30 040	14 x

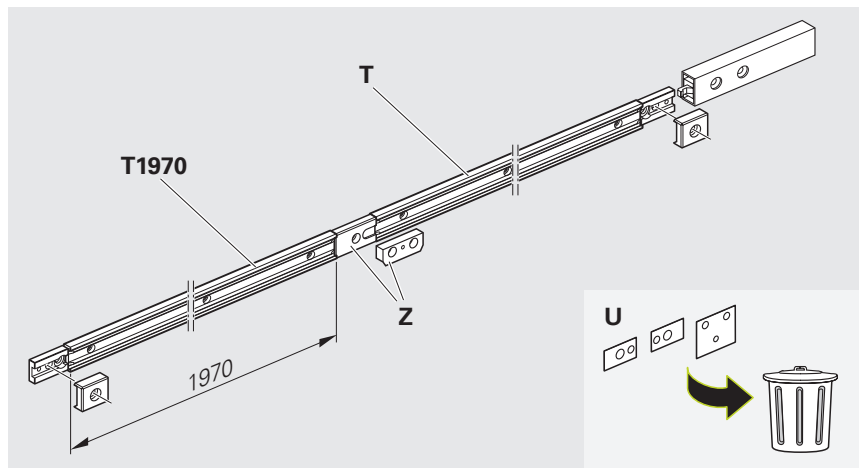



T1970 = Scale-tape carrier section with a length of 1970 mm

T = Remaining length of scale-tape carrier section

Z = Holder with fixing clamp

U = Shims for holders and spacers

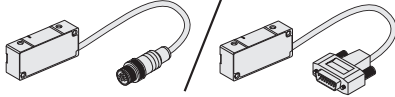
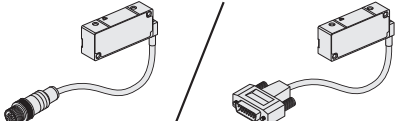
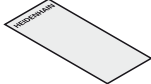
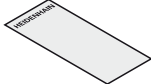
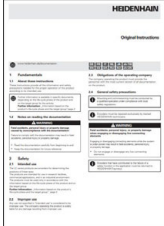
3.1.3 Items supplied: LIC 411, LIC 413, LIC 419 scanning head

Component	Figure
Scanning head	
or Scanning head with angled cable outlet	
Spacer shim 0.15 mm	
Spacer shim 0.75 mm (not needed)	
Operating Instructions	
Manufacturer's Inspection Document	

3.2 Mounting accessories

The following accessories can be ordered separately from HEIDENHAIN.

 For more information on the listed products, please refer to the applicable Mounting Instructions and the **Exposed Linear Encoders** brochure.

- ▶ www.heidenhain.com/documentation
- ▶ Enter the document ID **208960**

3.2.1 Accessories for mounting the parts kit

Accessories for mounting with adhesive film

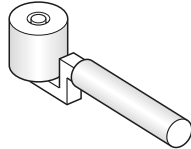
Designation	ID	Figure
Roller	276885-01	

3.2.2 Accessories for mounting the scanning head

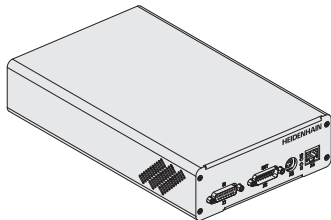
Designation	ID	Figure
PWM 21 inspection device	1200635-51	

Adjusting and Testing Software (ATS)

The ATS software is available for download free of charge from www.heidenhain.com/service/downloads/software/.

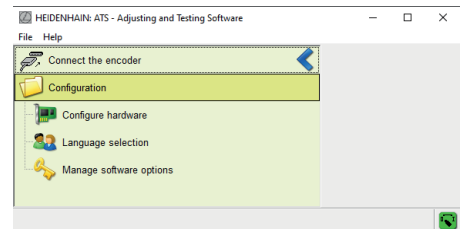

4 Mounting

This chapter describes the mounting requirements, different mounting variants, and all other tasks necessary when mounting.

4.1 Requirements and notes

NOTICE

Property damage due to inappropriate tools!

Using inappropriate tools for mounting or removal of the encoder may cause damage to the encoder.

- ▶ Do not use hammers
- ▶ Do not use pointed or sharp-edged tools

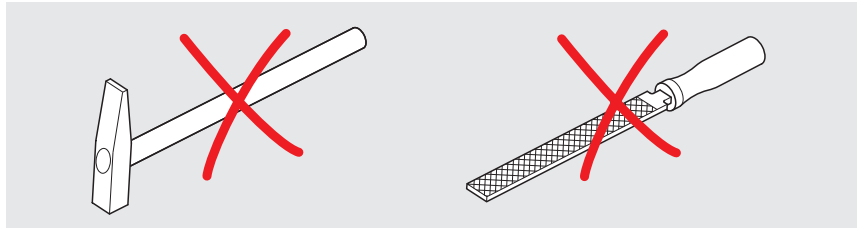

Choose a mounting attitude such that the traverse range is within the measuring length (**ML**) of the encoder.

Protect the graduation from direct contamination.

(**S**) = Beginning of measuring length (**ML**)

In order to ensure correct operation of the encoder, the scale or scale tape must be positioned correctly relative to the scanning head.

Code track at top if cable outlet is to the right.

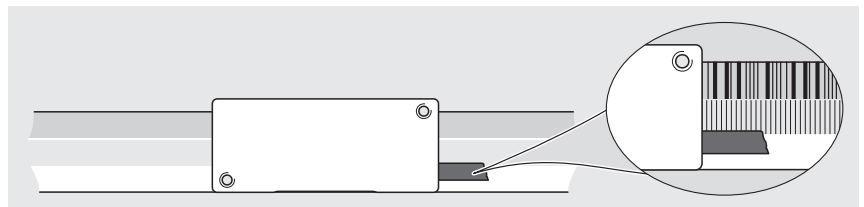
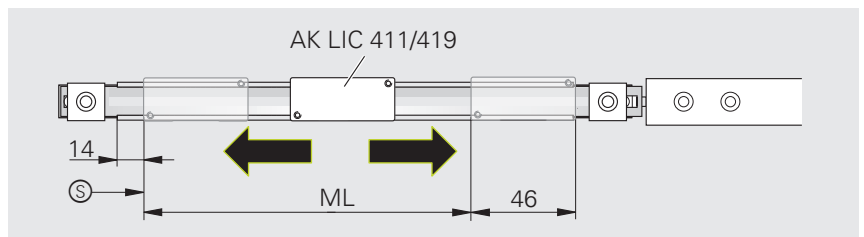

In order to avoid signal interferences, observe the minimum clearance from sources of interference (e.g., power lines).



For more information on sources of interference, refer to the **Interfaces of HEIDENHAIN Encoders** brochure.

- ▶ www.heidenhain.com/documentation
- ▶ Enter the document ID **1078628**

4.2 Mounting the parts kit

4.2.1 Choosing the mounting variant

Mounting variants for the parts kit

Mounting **with adhesive film**

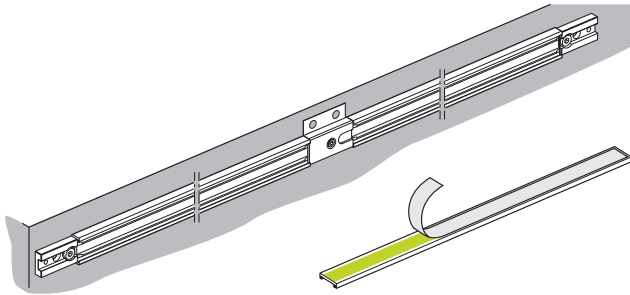

Page 16

Mounting **with screws**

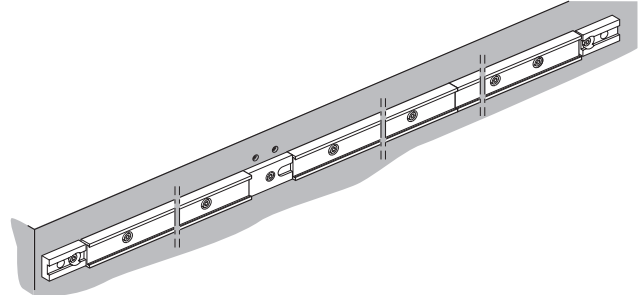

Page 22

4.2.2 Variant: Mounting with adhesive film

The mounting variant described in this chapter refers to mounting of the parts kit with an adhesive film.

An overview of the mounting variants is provided on Page 15.

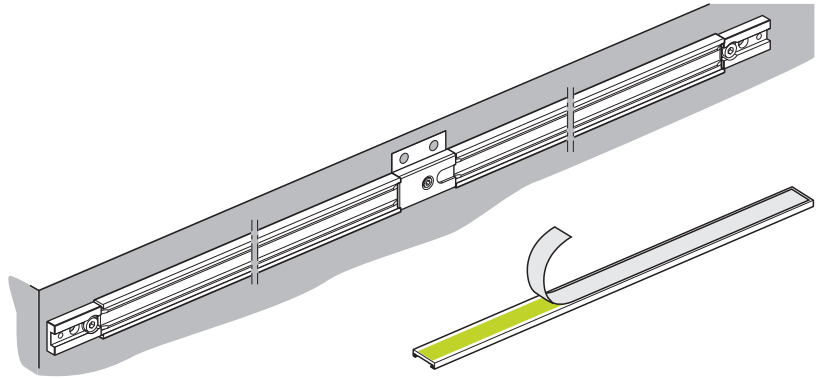

Notes on mounting with adhesive film

The number of required components depends on the measuring length (ML).

ML	T1970 / U / Z
≤ 3040	0 x
≤ 5040	1 x
≤ 7040	2 x
≤ 9040	3 x
≤ 11 040	4 x
≤ 13 040	5 x
.	.
.	.
≤ 30 040	14 x

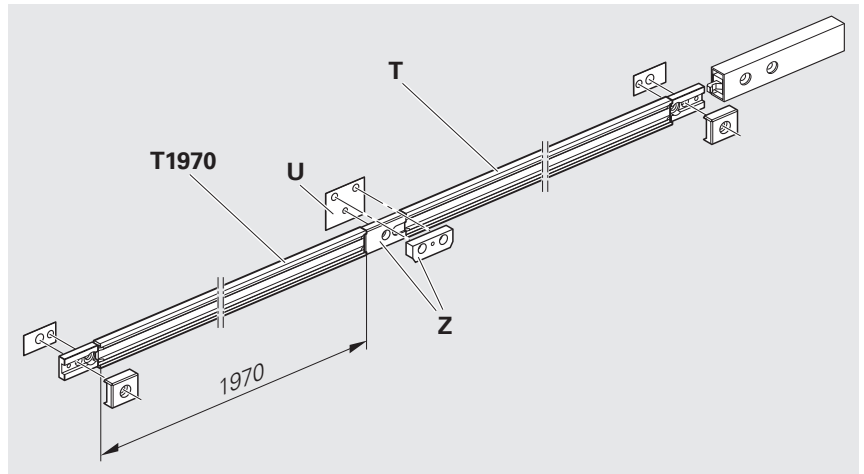

- T1970** = Scale-tape carrier section with a length of 1970 mm
- T** = Remaining length of scale-tape carrier section
- U** = Shim for holder
- Z** = Holder with fixing clamp

Note that the mounting surface, as well as the surface of the scale, must be clean and free of paint, dust or grease.

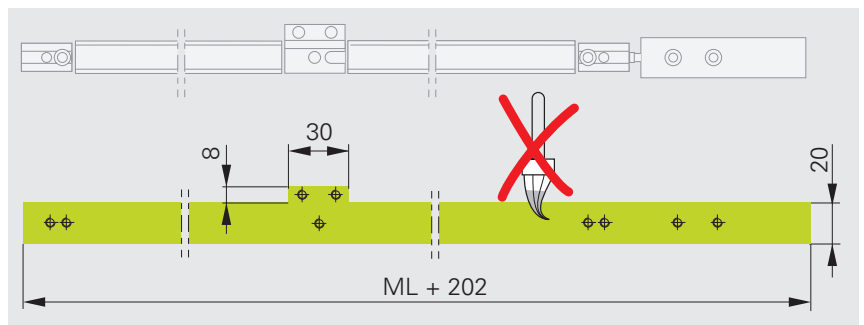

i You can mount the scale tape carriers by means of stop pins or an aligning rail.

The mounting tolerances refer to the machine guideway (**F**).

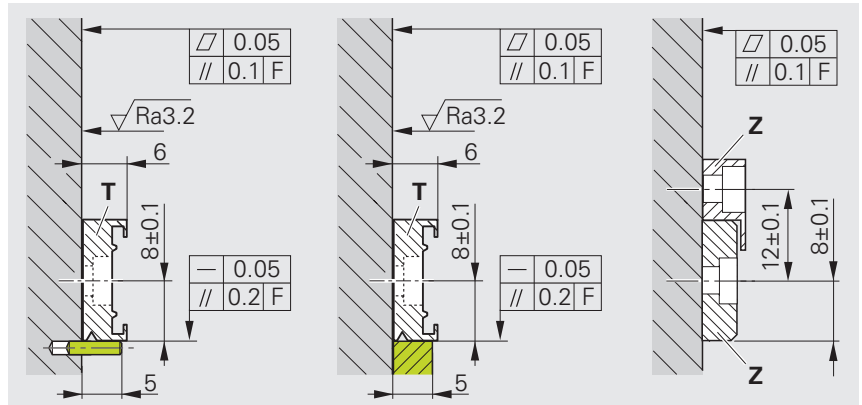

T = Scale-tape carrier section

Z = Holder with fixing clamp

Comply with the specified dimensions to account for thermal expansion.

ML ≤ 2040

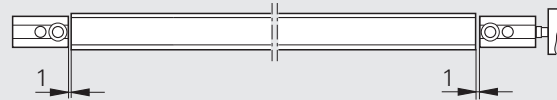

ML > 2040 – ≤ 3040

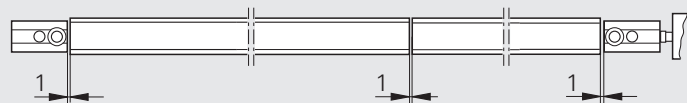

ML > 3040

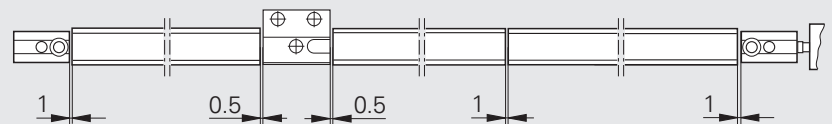

Materials and tools

For this task, the following materials and tools are needed:

Included in delivery

- Scale-tape carrier sections
- Shim, holder, fixing clamp as needed
- Shims, spacers, and mounting blocks
- Tensioning device with cylinder head screws

To be provided separately

- Stop pins
- Screws (DIN 4762 – M3×6)
- Screws (DIN 7984 – M4×8)
- Torque wrench (hexagon socket for 2.5 mm)
- Torque wrench (hexagon socket for 3.5 mm)
- Roller

Bonding the scale tape carrier

- ▶ Insert the stop pins

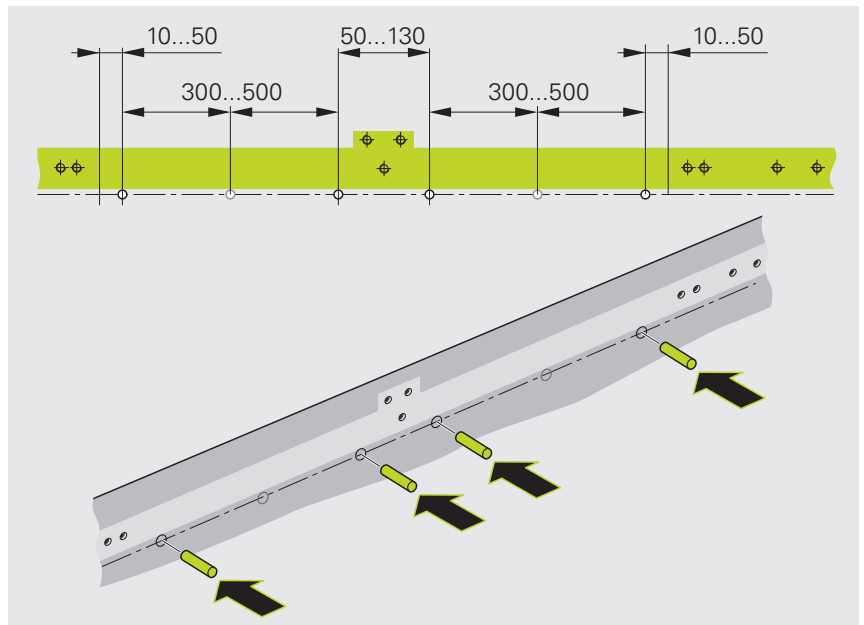

Attach the scale tape carriers with adhesive mounting film only at a temperature of $> 15\text{ }^{\circ}\text{C}$.

Pay attention to the expiration date on the package.

- ▶ Remove the protective foil from the adhesive film

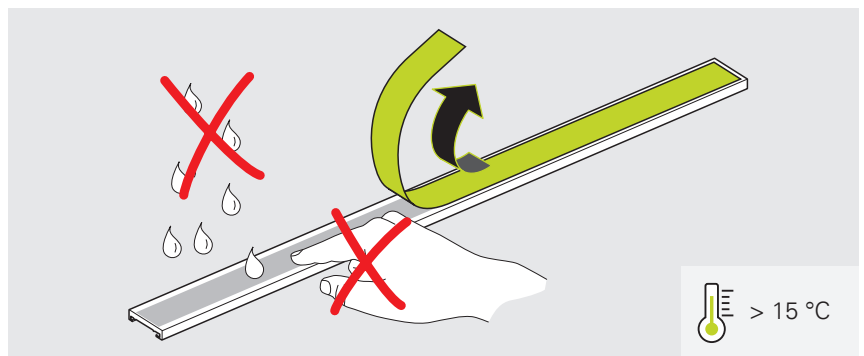

Ensure that the scale tape carriers are positioned correctly.

Use the shim (**U**) to compensate for the thickness of the adhesive mounting film.

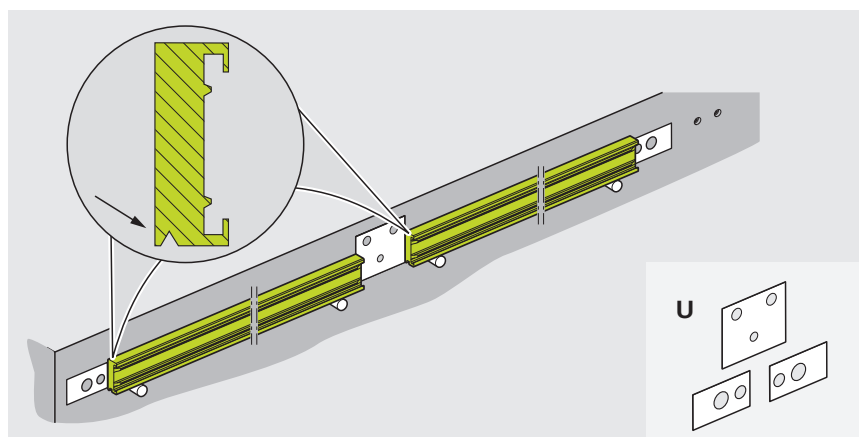

- ▶ Carefully place the scale tape carriers onto the stop pins
- ▶ Push the scale tape carrier against the mounting surface and lightly press them against the mounting surface
- ▶ If holders are required, fasten them with the specified torque
- ▶ Fasten the spacers with the specified torque

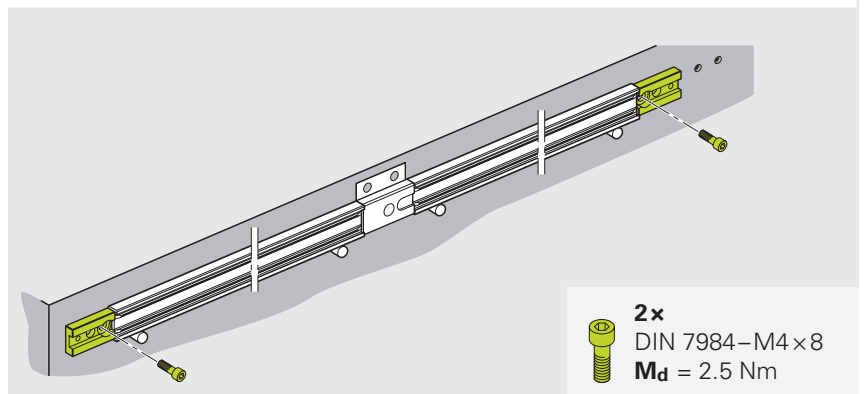
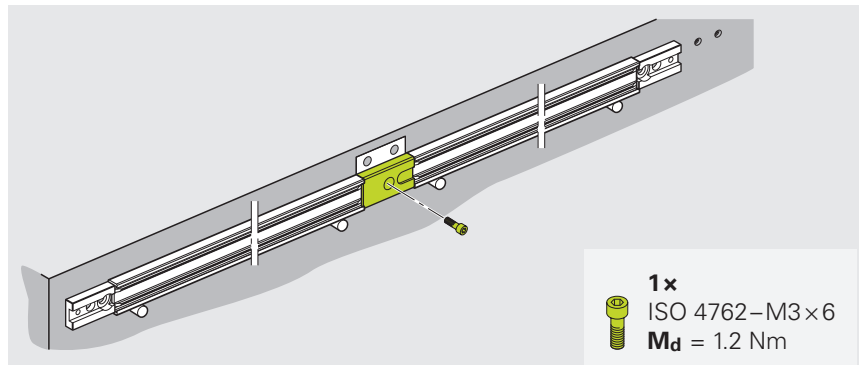

- ▶ Starting from the center, evenly press the scale-tape carriers onto the mounting surface using the roller

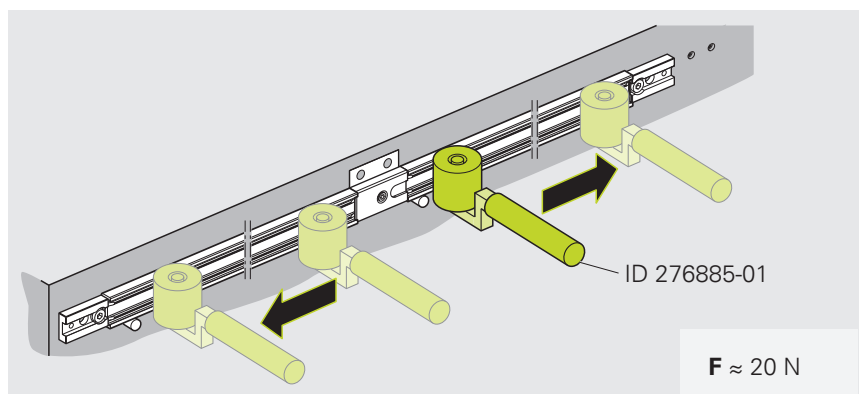

- ▶ Remove the stop pins
- ▶ Do not perform further work on the scale tape carriers until the maximum adhesive force has been reached

i The maximum adhesive force of the mounting film is reached at room temperature after approx. 70 hours.

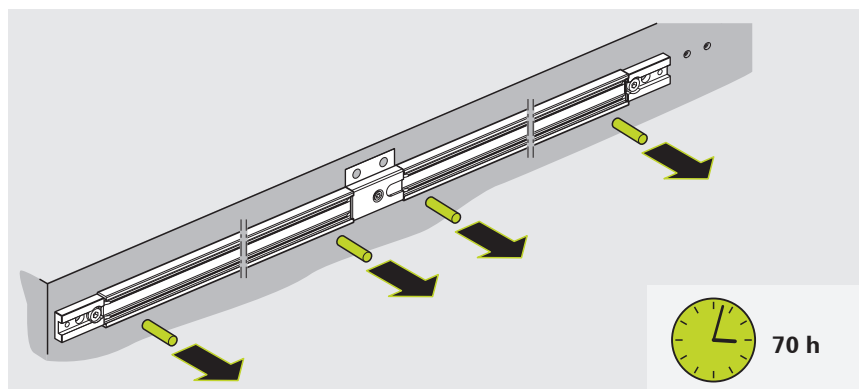

Mounting the scale tape

NOTICE**Property damage due to mechanical stress!**

- ▶ Do not bend the scale tape

- ▶ If necessary, remove the protective film from the scale tape

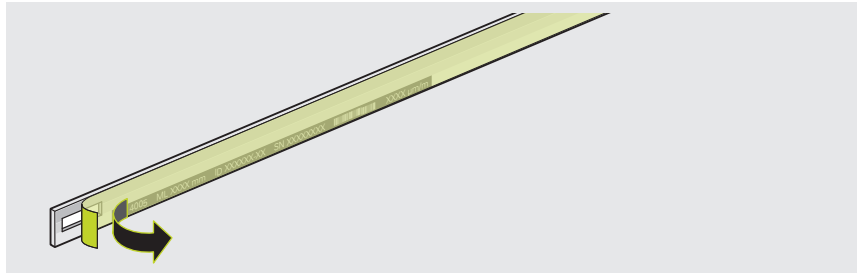

- ▶ Note down the shortening factor (V_k)

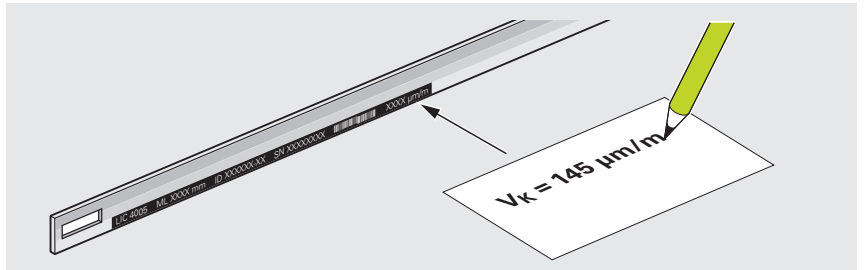

- ▶ Slide the scale tape into the scale tape carrier

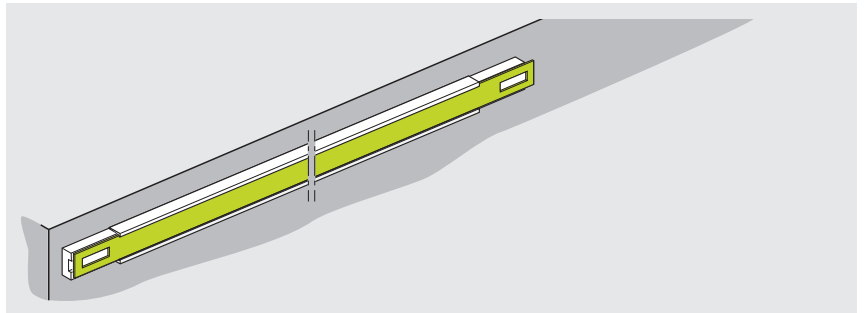

- ▶ Fasten the mounting block with the specified torque

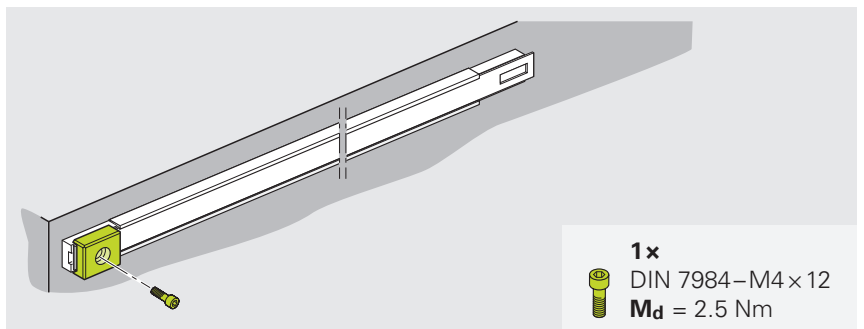

- ▶ Hook the scale tape into the tensioning device
- ▶ Fasten the tensioning device with the specified torque

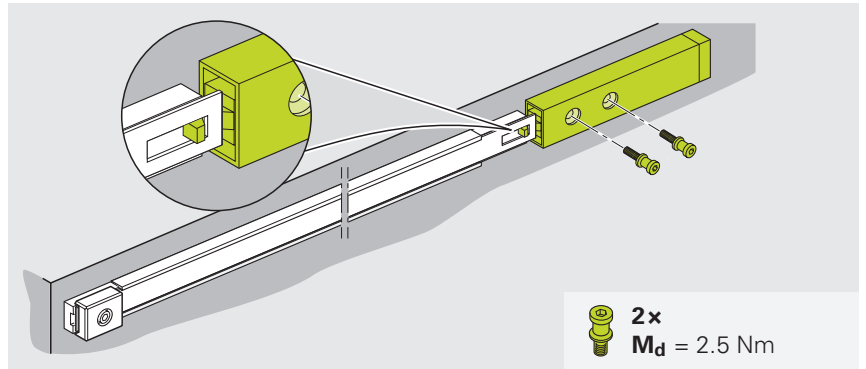

Next step: "Mounting the scanning head", Page 27

4.2.3 Variant: Mounting with screws

The mounting variant described in this chapter refers to mounting of the parts kit with screws.

An overview of the mounting variants is provided on Page 15.

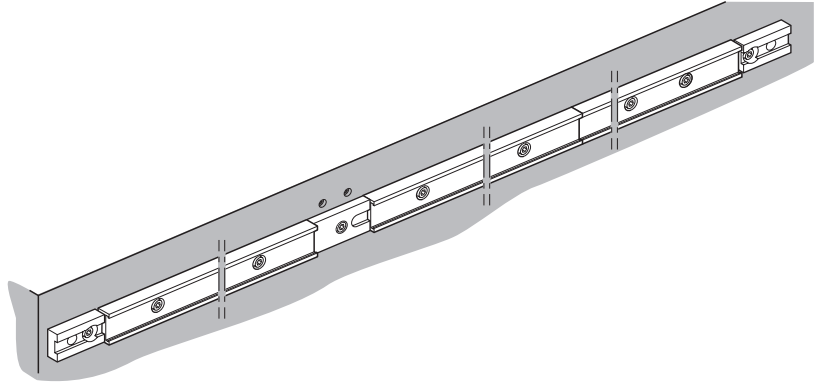

Notes on mounting with screws

The number of required components depends on the measuring length (ML).

ML	T1970 / Z
≤ 3040	0 x
≤ 5040	1 x
≤ 7040	2 x
≤ 9040	3 x
≤ 11 040	4 x
≤ 13 040	5 x
.	.
.	.
≤ 30 040	14 x

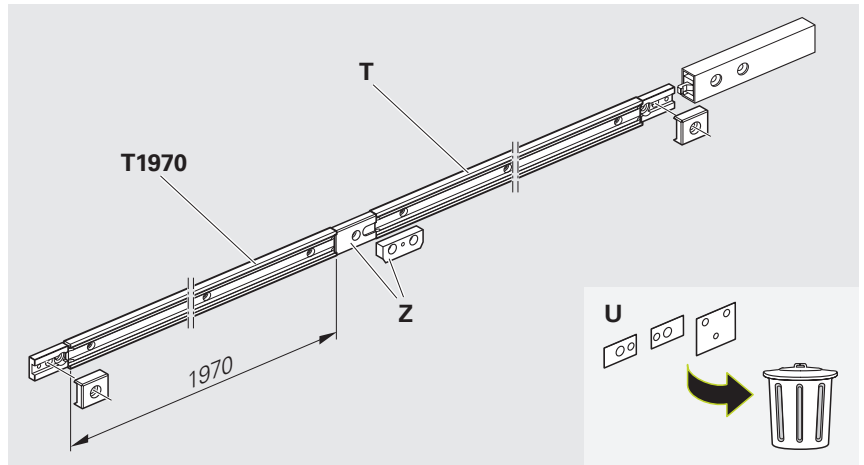

- T1970** = Scale-tape carrier section with a length of 1970 mm
- T** = Remaining length of scale-tape carrier section
- Z** = Holder with fixing clamp
- U** = Shims for holders and spacers

Note that the mounting surface, as well as the surface of the scale, must be clean and free of paint, dust or grease.

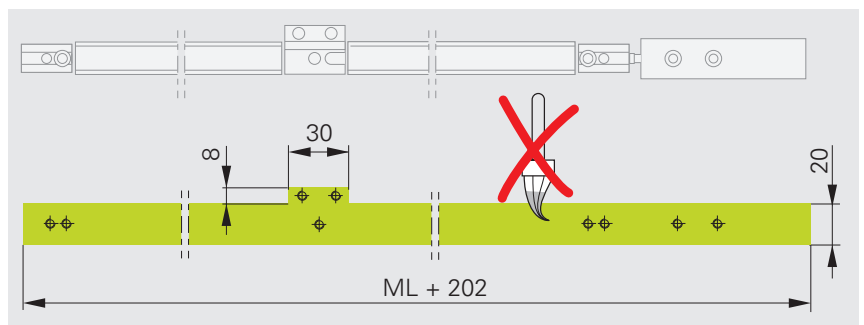

i You can mount the scale tape carriers by means of stop pins or an aligning rail.

The mounting tolerances refer to the machine guideway (**F**).

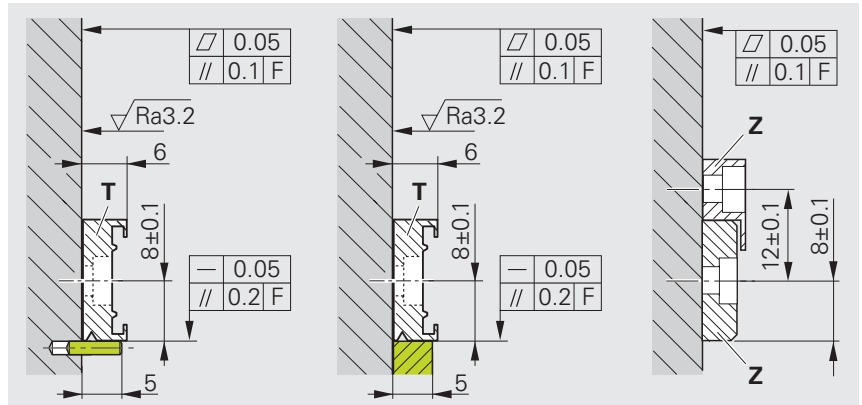

T = Scale-tape carrier section
Z = Holder with fixing clamp

Comply with the specified dimensions to account for thermal expansion.

ML ≤ 2040

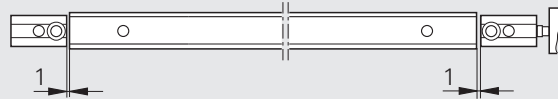

ML > 2040 – ≤ 3040

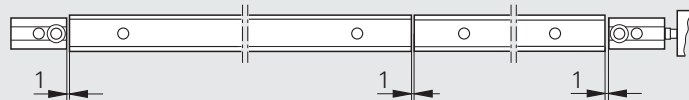

ML > 3040

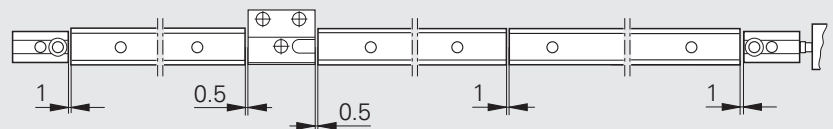

Materials and tools

For this task, the following materials and tools are needed:

Included in delivery

- Scale-tape carrier sections
- Holder and fixing clamp as needed
- Spacers and mounting blocks
- Tensioning device with cylinder head screws

To be provided separately

- Screws (DIN 4762 – M3x6)
- Screws (DIN 7984 – M4x8)
- Torque wrench (hexagon socket for 2.5 mm)
- Torque wrench (hexagon socket for 3.5 mm)

Screw-fastening the scale tape carrier

The mounting tolerances refer to the machine guideway (**F**).

- ▶ Fasten the scale-tape carrier sections with the specified torque
- ▶ If holders are required, fasten them with the specified torque
- ▶ Fasten the spacers with the specified torque

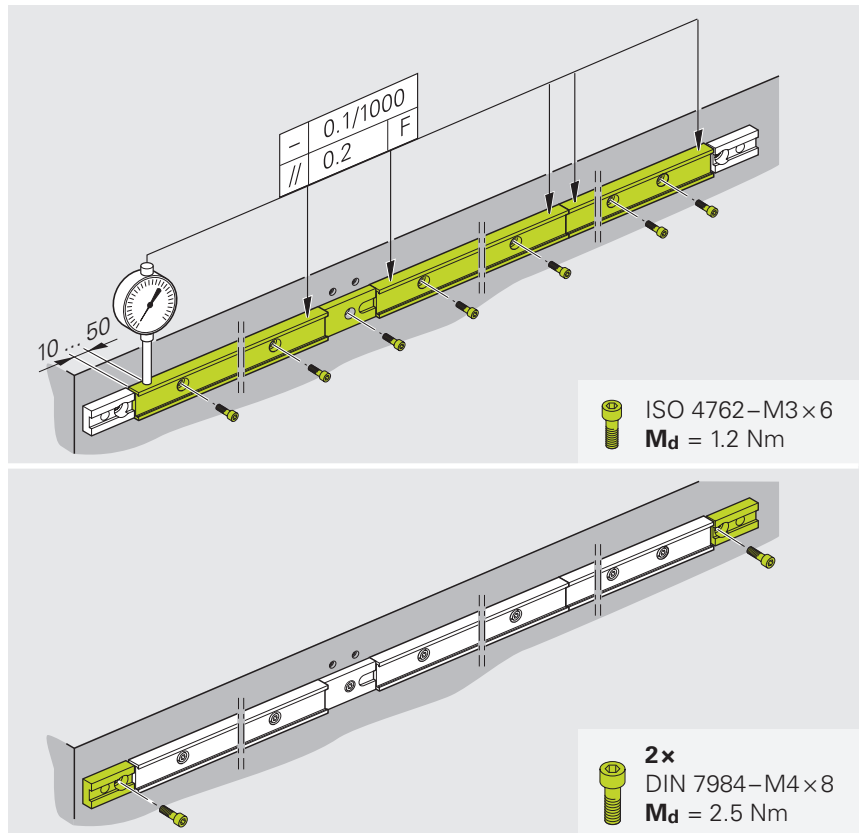

Mounting the scale tape

NOTICE

Property damage due to mechanical stress!

- ▶ Do not bend the scale tape

- ▶ If necessary, remove the protective film from the scale tape

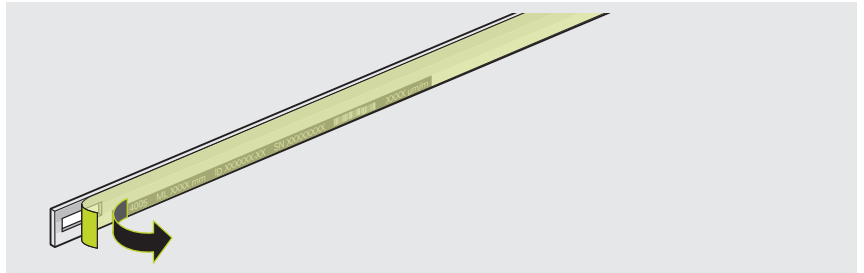

- ▶ Note down the shortening factor (V_k)

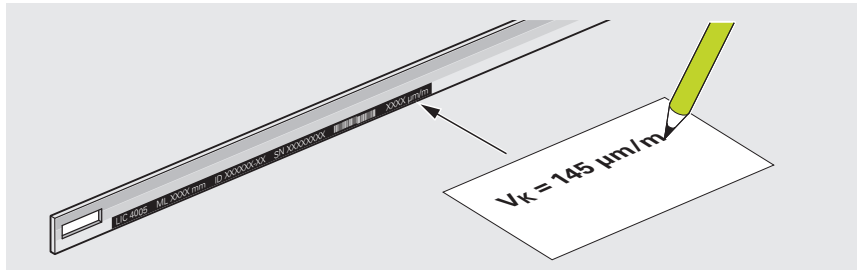

- ▶ Slide the scale tape into the scale tape carrier

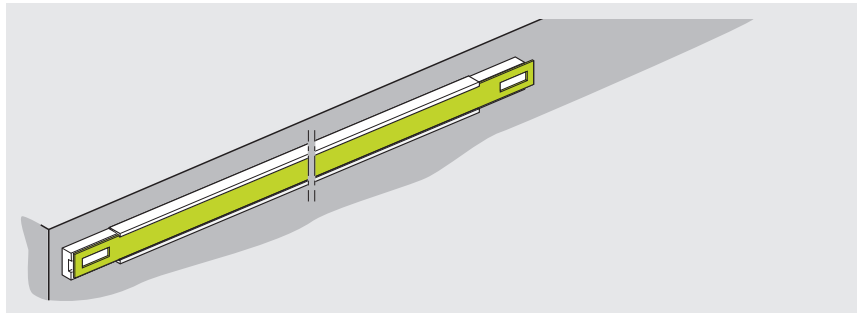

- ▶ Fasten the mounting block with the specified torque

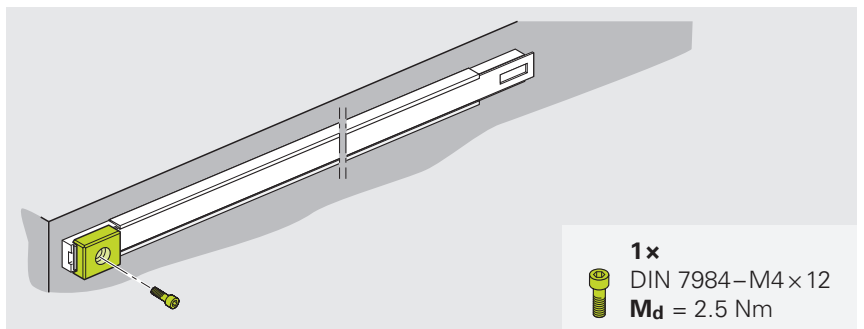

- ▶ Hook the scale tape into the tensioning device
- ▶ Fasten the tensioning device with the specified torque

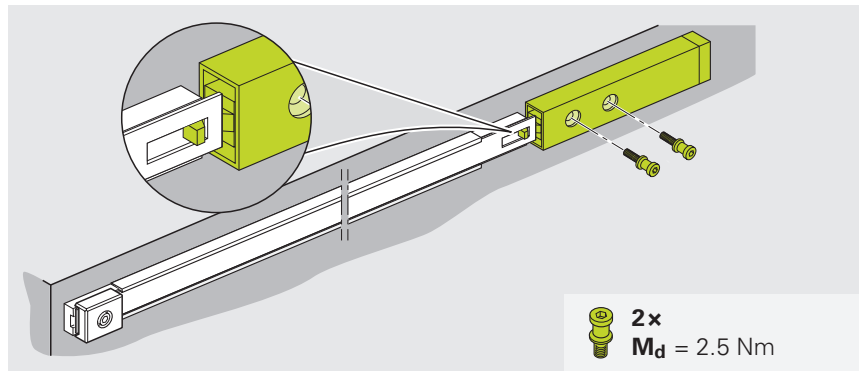

Next step: "Mounting the scanning head", Page 27

4.3 Mounting the scanning head

4.3.1 Choosing the mounting variant

Mounting variants for the scanning head

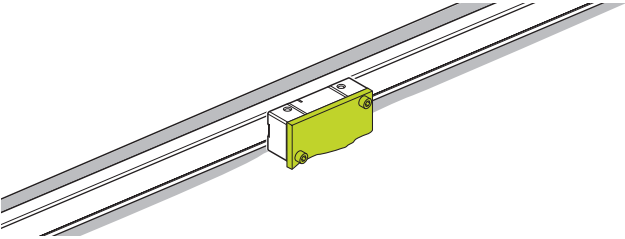
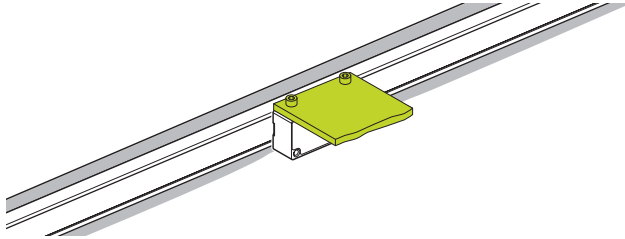
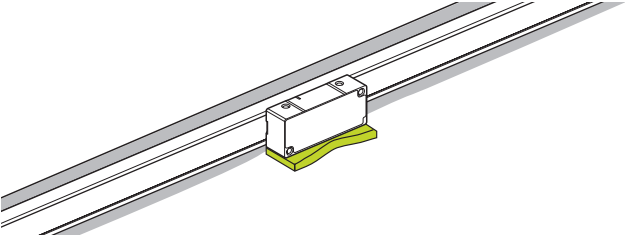
Holder on the side	Holder at the top
 <p>Page 28</p>	 <p>Page 32</p>
<p>Holder at the bottom</p>  <p>Page 36</p>	

4.3.2 Variant: Mounting with the holder on the side

The mounting variant described in this chapter refers to mounting of the scanning head with the holder on the side.

An overview of the mounting variants is provided on Page 27.

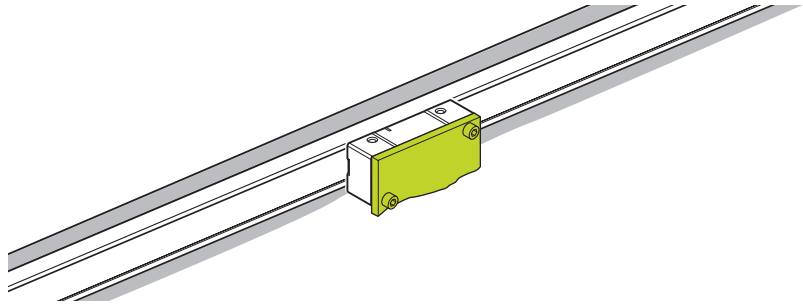

Notes on mounting the scanning head with the holder on the side

i The tightening torques of the mounting screws are only valid for mounting on steel.

i If necessary, clean the graduation and the scanning head with a lint-free cloth and isopropyl alcohol.

NOTICE

Property damage due to unsuitable cleaning agents!

- ▶ Use only isopropyl alcohol to clean the encoder
- ▶ Clean the encoder with a lint-free cloth

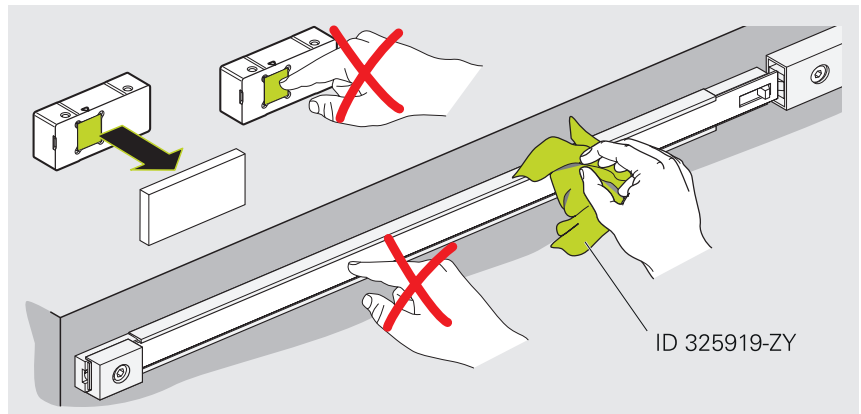

Pay attention to the mounting dimensions. Deviations from the mounting dimensions lead to imprecise measurement results during operation.

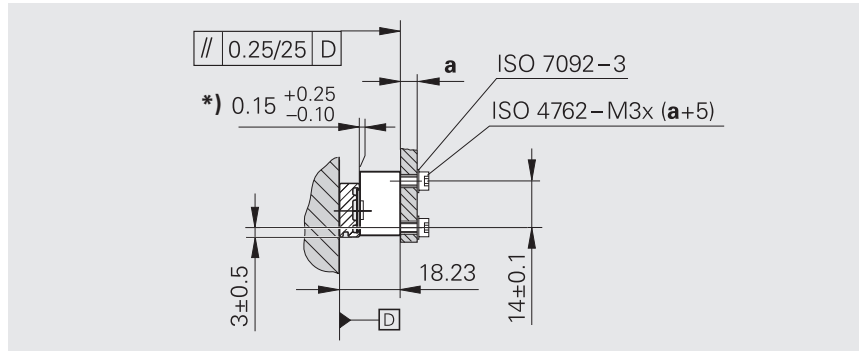

*) Mounting clearance between the scanning head and scale tape carrier.

Special case for ID 1196309-xx

Limited mounting tolerance resulting from deactivated code-connection expansion

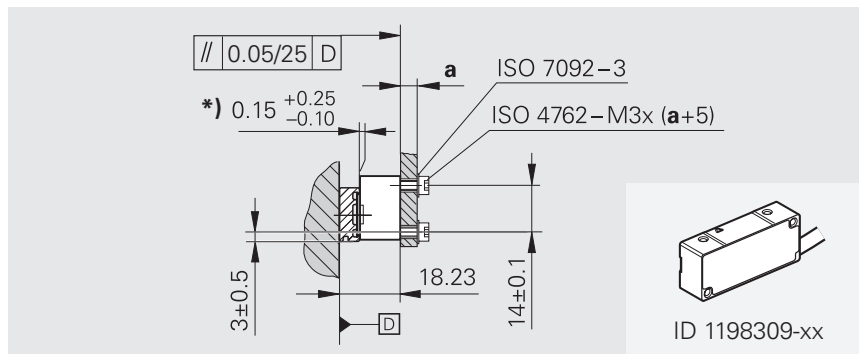

*) Mounting clearance between the scanning head and scale tape carrier.

Additional notes on mounting the scanning head with angled cable outlet

NOTICE**Property damage due to mechanical stress!**

Exceeding the pivot range may damage the scanning head.

- Do not pull the cable
- Observe the maximum permissible pivot range of the adjustable cable outlet (0° to 180°)
- Rotate the cable only a few times (less than 10)

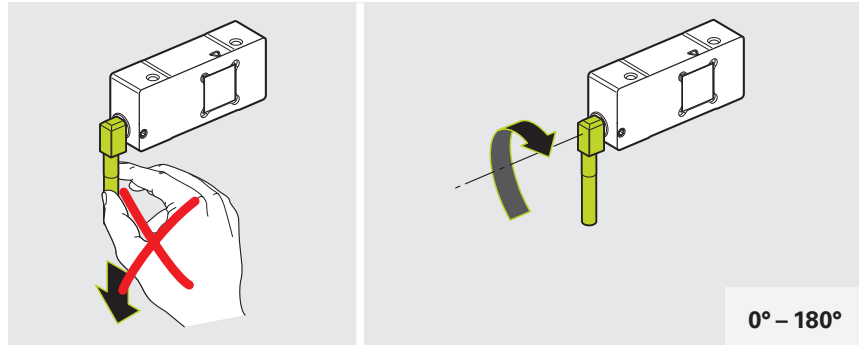

0° – 180°

Adjusting the angular position of the cable

- ▶ Loosen the setscrew

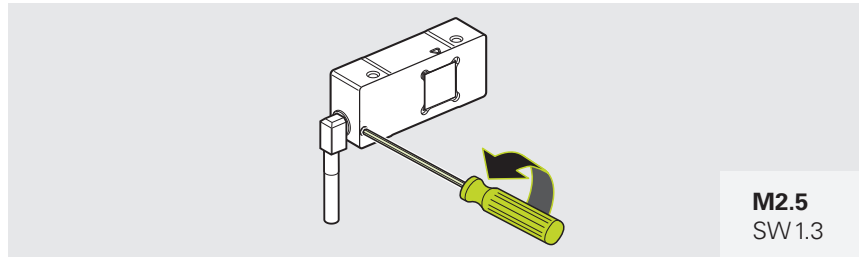
M2.5
SW 1.3

- ▶ Rotate the cable to the desired angular position

i If necessary, use a flat wrench to rotate the sleeve

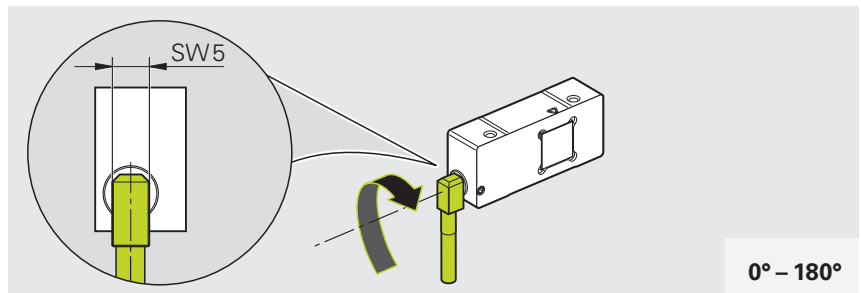

0° – 180°

- ▶ Tighten the setscrew with the specified torque

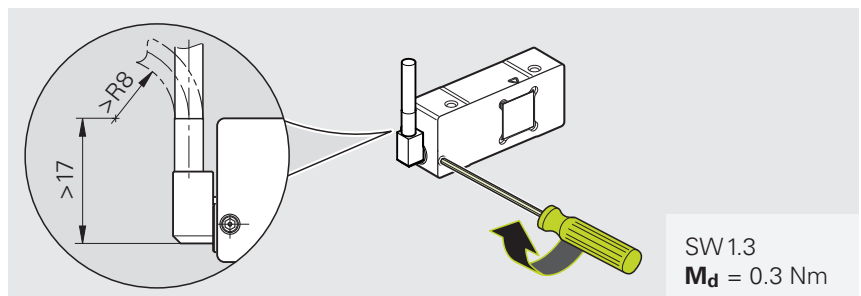
SW 1.3
 $M_d = 0.3 \text{ Nm}$ **Materials and tools**

For this task, the following materials and tools are needed:

Included in delivery

- Spacer shim

To be provided separately

- Two screws (ISO 4762–M3×(a+5))
- Two washers (ISO 7092–3)
- Torque wrench (hexagon socket for 2.5 mm)

Mounting the scanning head

- ▶ If necessary, remove the protective cap from the scanning head

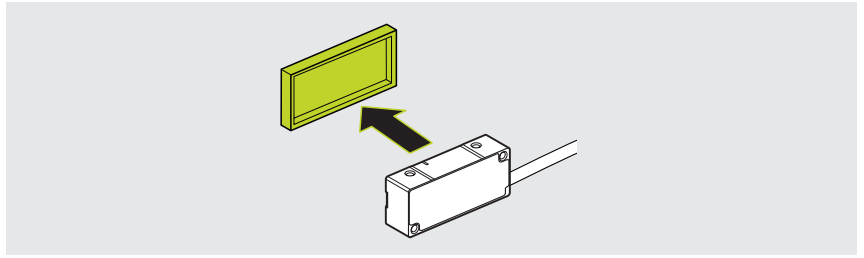

- ▶ Prepare the spacer shim

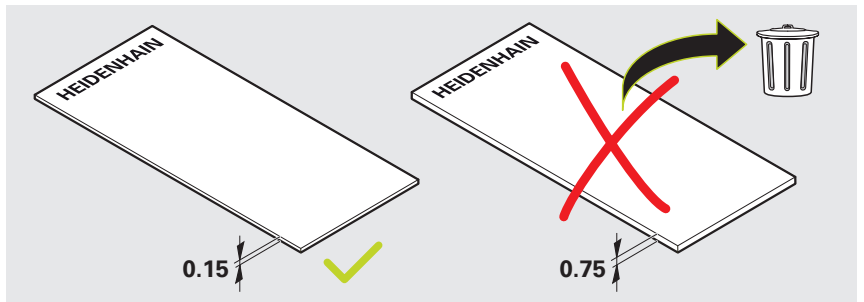

- ▶ Use the spacer shim to set the mounting clearance
- ▶ Lightly tighten the screws on the scanning head
- ▶ Remove the spacer shim

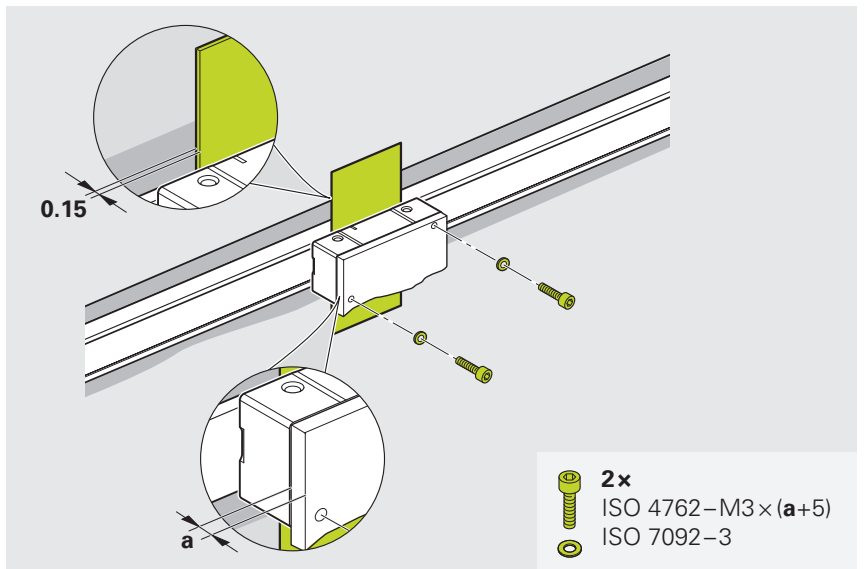

Next step: "Adjustment and diagnosis", Page 40

4.3.3 Variant: Mounting with the holder at top

The mounting variant described in this chapter refers to mounting of the scanning head with the holder at top.

An overview of the mounting variants is provided on Page 27.

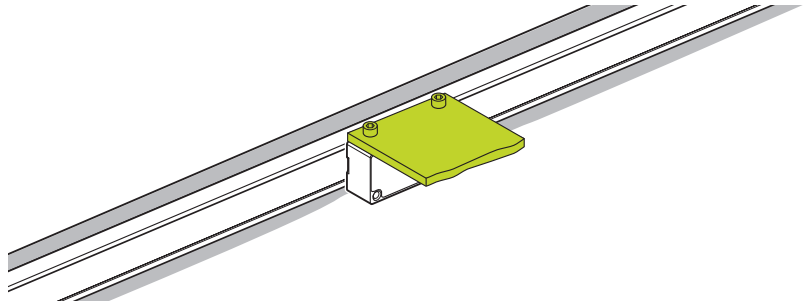

Notes on mounting the scanning head with the holder at top

i The tightening torques of the mounting screws are only valid for mounting on steel.

i If necessary, clean the graduation and the scanning head with a lint-free cloth and isopropyl alcohol.

NOTICE

Property damage due to unsuitable cleaning agents!

- ▶ Use only isopropyl alcohol to clean the encoder
- ▶ Clean the encoder with a lint-free cloth

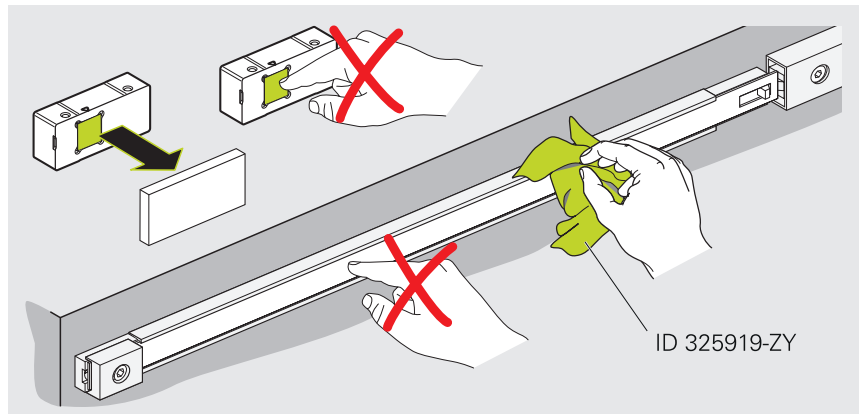

Pay attention to the mounting dimensions. Deviations from the mounting dimensions lead to imprecise measurement results during operation.

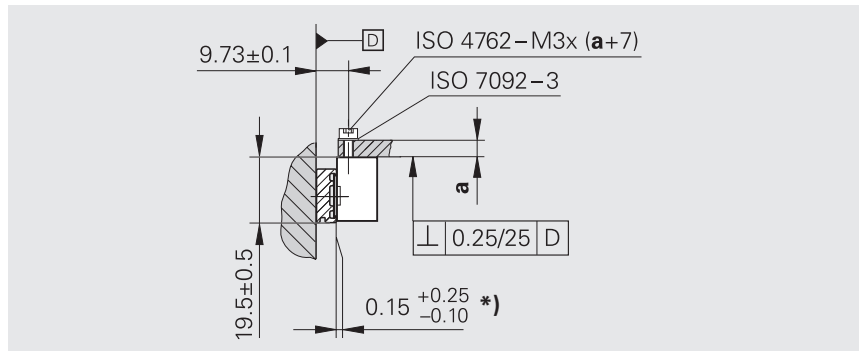

*) Mounting clearance between the scanning head and scale tape carrier.

Special case for ID 1196309-xx

Limited mounting tolerance resulting from deactivated code-connection expansion

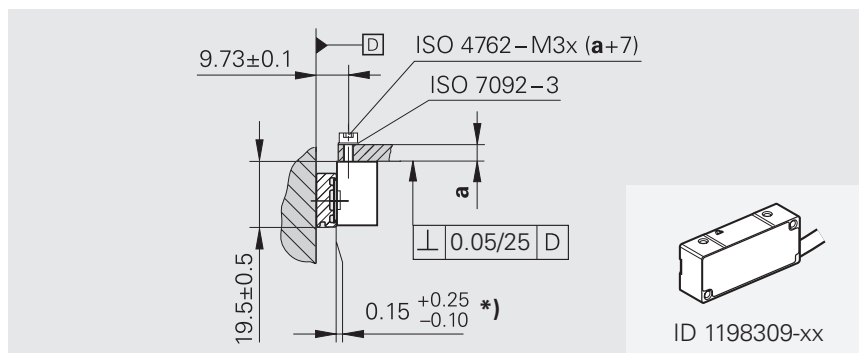

*) Mounting clearance between the scanning head and scale tape carrier.

Additional notes on mounting the scanning head with angled cable outlet

NOTICE**Property damage due to mechanical stress!**

Exceeding the pivot range may damage the scanning head.

- Do not pull the cable
- Observe the maximum permissible pivot range of the adjustable cable outlet (0° to 180°)
- Rotate the cable only a few times (less than 10)

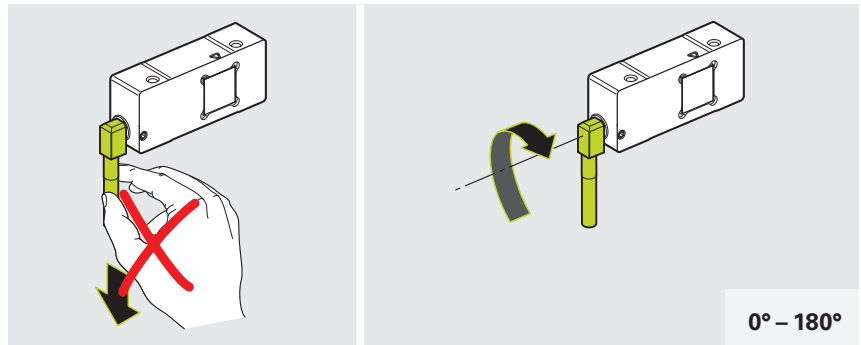
**Adjusting the angular position of the cable**

- ▶ Loosen the setscrew

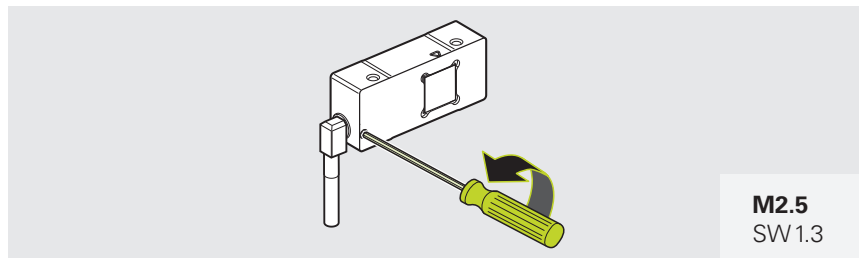

- ▶ Rotate the cable to the desired angular position

i If necessary, use a flat wrench to rotate the sleeve

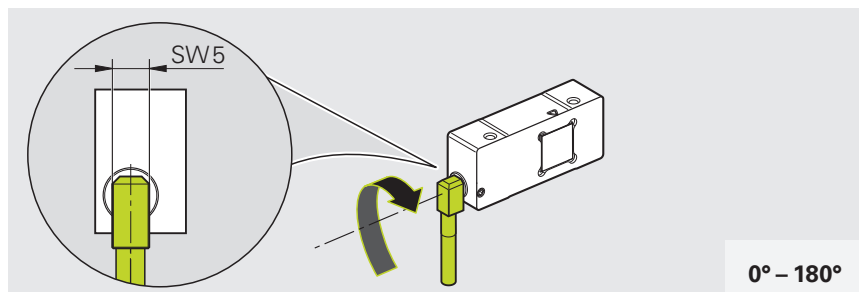

- ▶ Tighten the setscrew with the specified torque

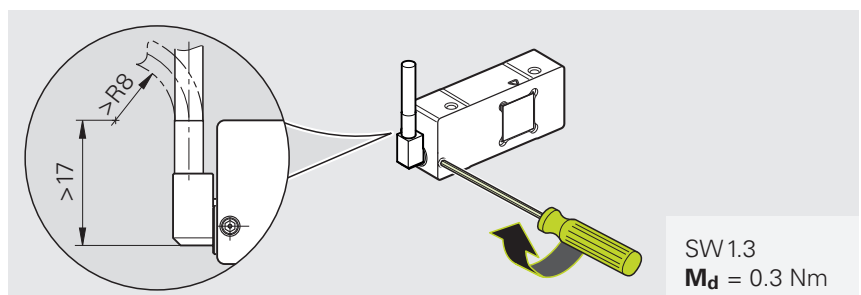
**Materials and tools**

For this task, the following materials and tools are needed:

Included in delivery

- Spacer shim

To be provided separately

- Two screws (ISO 4762-M3x(a+7))
- Two washers (ISO 7092-3)
- Torque wrench (hexagon socket for 2.5 mm)

Mounting the scanning head

- ▶ If necessary, remove the protective cap from the scanning head

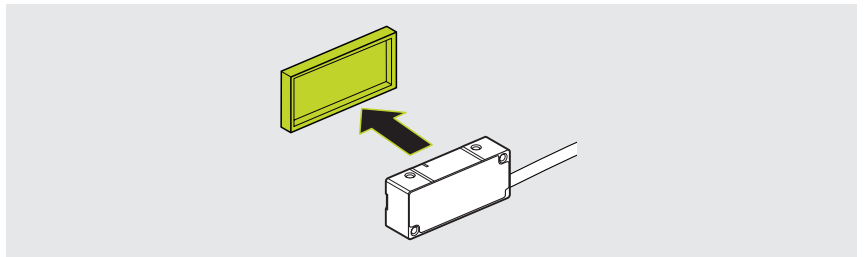

- ▶ Prepare the spacer shim

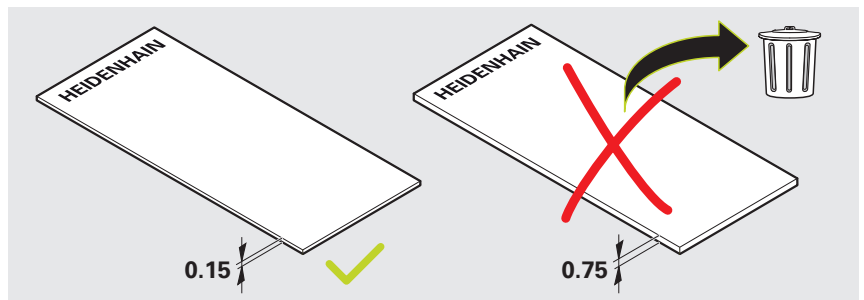

- ▶ Use the spacer shim to set the mounting clearance
- ▶ Lightly tighten the screws on the scanning head
- ▶ Remove the spacer shim

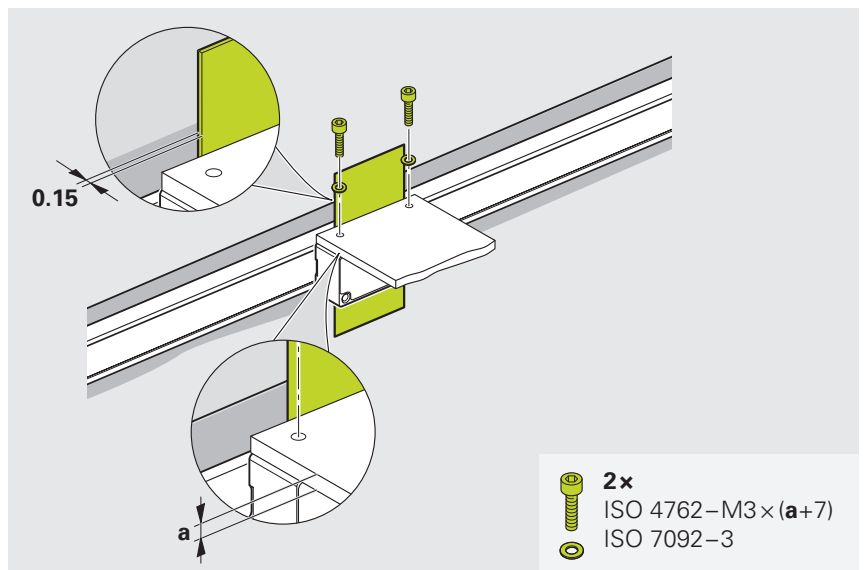

Next step: "Adjustment and diagnosis", Page 40

4.3.4 Variant: Mounting with the holder at bottom

The mounting variant described in this chapter refers to mounting of the scanning head with the holder at bottom.

An overview of the mounting variants is provided on Page 27.

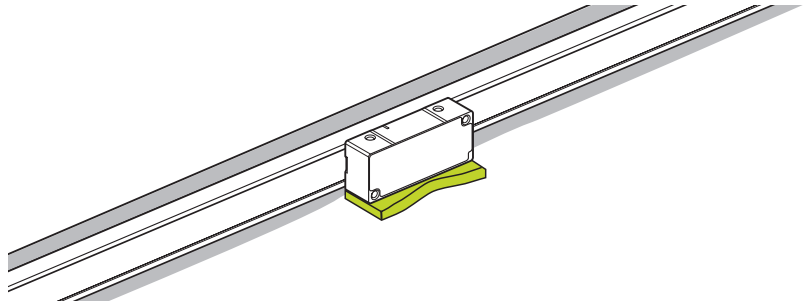

Notes on mounting the scanning head with the holder at bottom

i The tightening torques of the mounting screws are only valid for mounting on steel.

i If necessary, clean the graduation and the scanning head with a lint-free cloth and isopropyl alcohol.

NOTICE

Property damage due to unsuitable cleaning agents!

- ▶ Use only isopropyl alcohol to clean the encoder
- ▶ Clean the encoder with a lint-free cloth

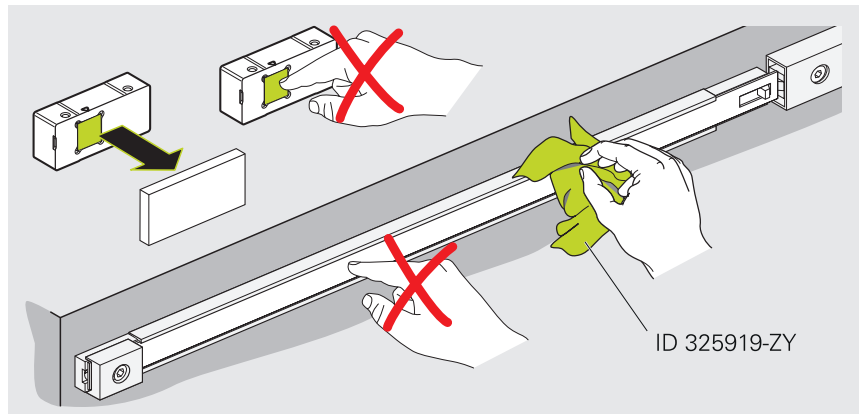

Pay attention to the mounting dimensions. Deviations from the mounting dimensions lead to imprecise measurement results during operation.

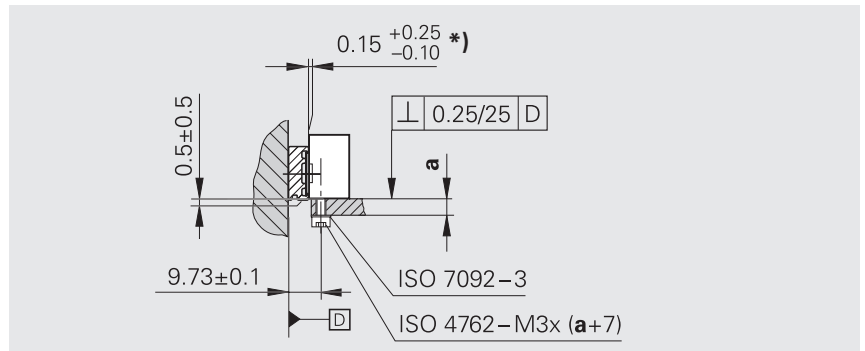

*) Mounting clearance between the scanning head and scale tape carrier.

Special case for ID 1196309-xx

Limited mounting tolerance resulting from deactivated code-connection expansion

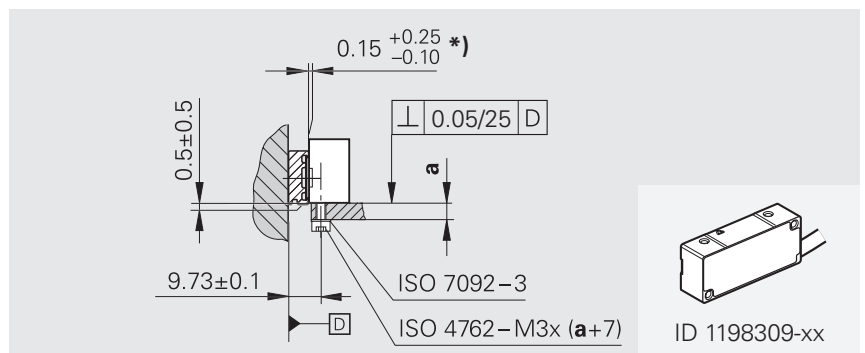

*) Mounting clearance between the scanning head and scale tape carrier.

Additional notes on mounting the scanning head with angled cable outlet

NOTICE**Property damage due to mechanical stress!**

Exceeding the pivot range may damage the scanning head.

- Do not pull the cable
- Observe the maximum permissible pivot range of the adjustable cable outlet (0° to 180°)
- Rotate the cable only a few times (less than 10)

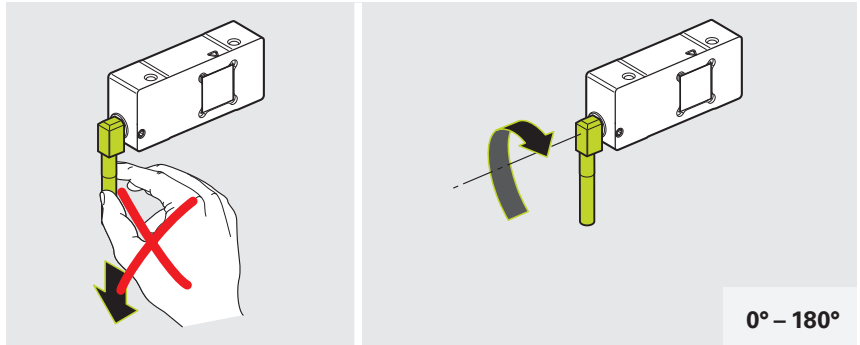
**Adjusting the angular position of the cable**

- ▶ Loosen the setscrew

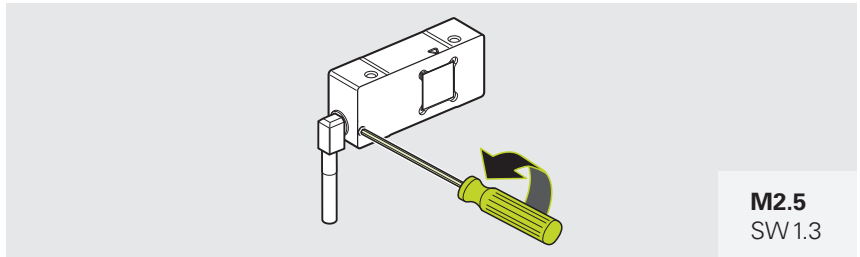

- ▶ Rotate the cable to the desired angular position

i If necessary, use a flat wrench to rotate the sleeve

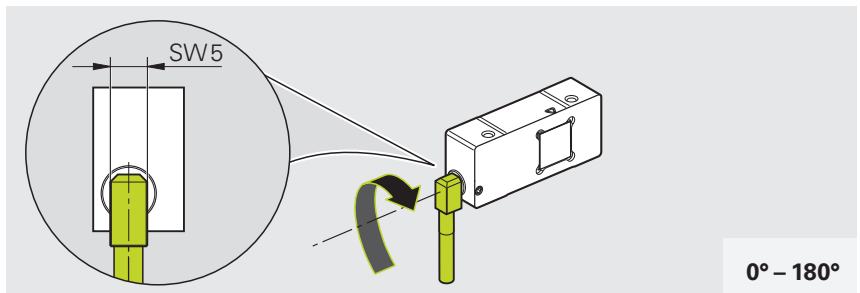

- ▶ Tighten the setscrew with the specified torque

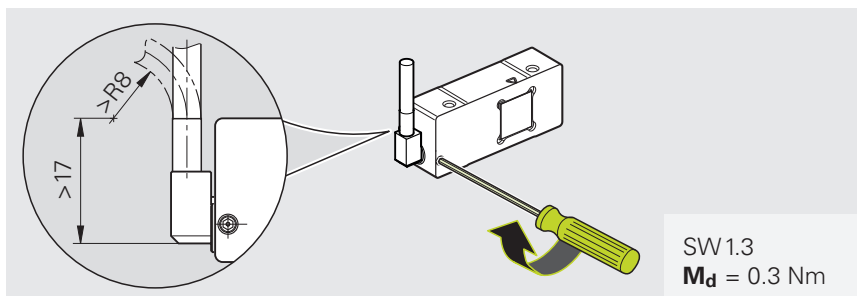
**Materials and tools**

For this task, the following materials and tools are needed:

Included in delivery

- Spacer shim

To be provided separately

- Two screws (ISO 4762-M3x(a+7))
- Two washers (ISO 7092-3)
- Torque wrench (hexagon socket for 2.5 mm)

Mounting the scanning head

- ▶ If necessary, remove the protective cap from the scanning head

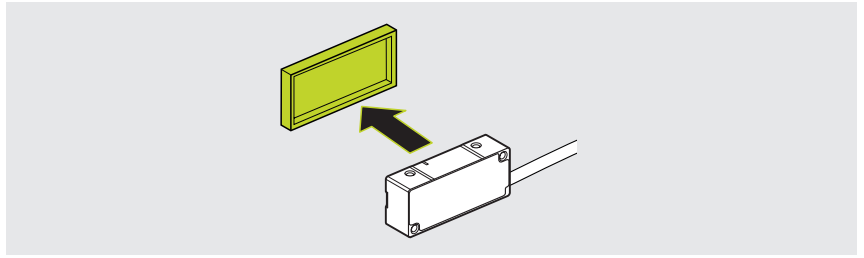

- ▶ Prepare the spacer shim

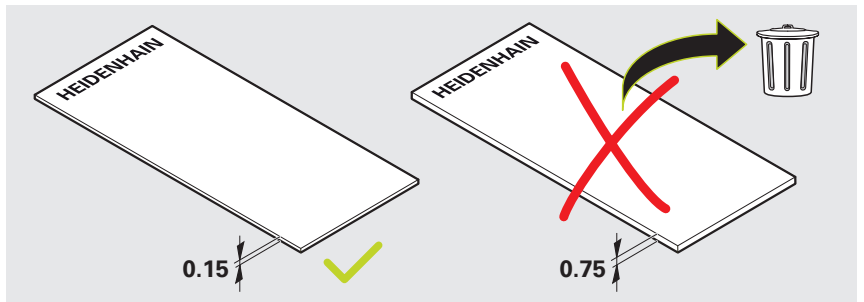

- ▶ Use the spacer shim to set the mounting clearance
- ▶ Lightly tighten the screws on the scanning head
- ▶ Remove the spacer shim

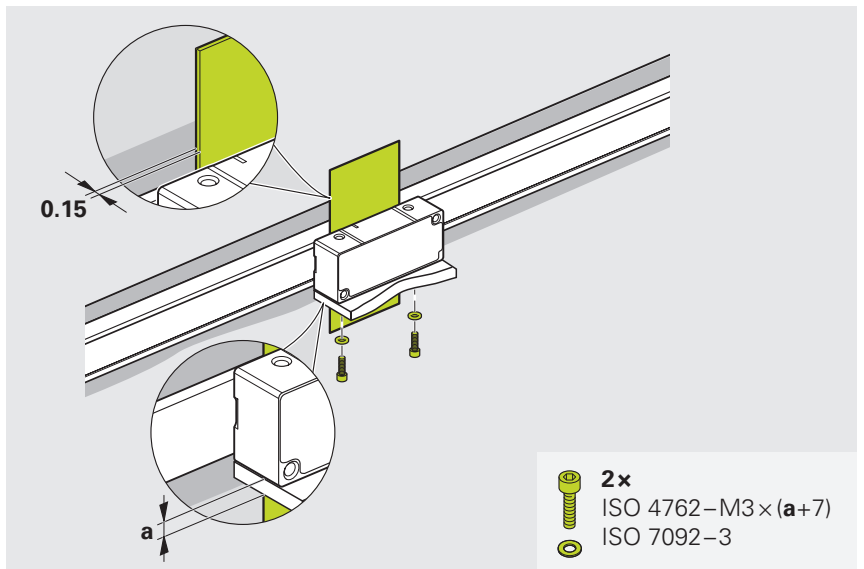

Next step: "Adjustment and diagnosis", Page 40

5 Adjustment and diagnosis

This chapter describes the continuity test, as well as the adjustment and diagnosis with the PWM 21 and the Adjusting and Testing Software (ATS).

5.1 Requirements and notes

The following components are necessary for adjusting and diagnosing HEIDENHAIN encoders:

- PWM 21
- ATS: version 3.2.xx and later provide integrated local encoder database for automatic encoder detection

The ATS software is available for download free of charge from www.heidenhain.com/service/downloads/software/.



For more information, see the **Exposed Linear Encoders** brochure.

- ▶ www.heidenhain.com/documentation
- ▶ Enter the document ID **208960**



For more information, see the associated Adjusting and Testing Software documentation.

- ▶ www.heidenhain.com/documentation
- ▶ Enter the document ID **543734**

5.2 Continuity check

Materials and tools

For this mounting step, the following materials and tools are needed:

Included in delivery

To be provided separately

- Resistance measuring device

5.2.1 Measuring the electrical resistance

- ▶ Check the electrical resistance between the connector housing and the machine



The electrical resistance between the connector housing and the machine must be $< 1 \Omega$.

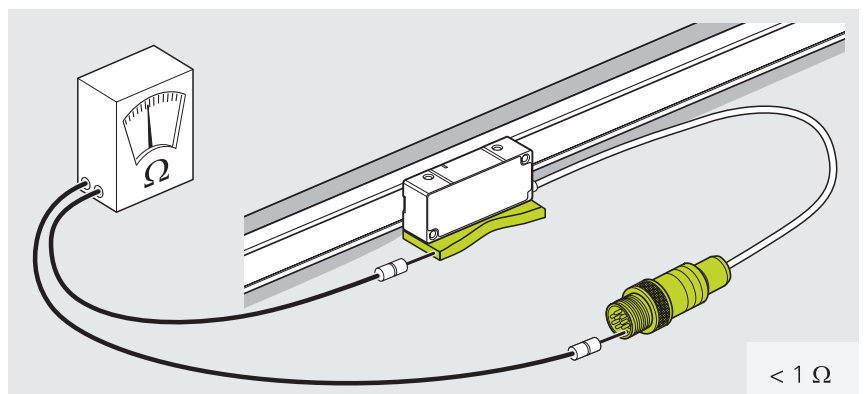

5.3 Connecting the encoder to the ATS

5.3.1 Connecting the encoder

- ▶ Connect the encoder to the PWM 21
- ▶ Switch on the PWM 21

5.3.2 Selecting the connection

Connection options

Connecting the encoder using its ID	Connecting the encoder manually
Recommended option with automatic determination of the measuring parameters. Page 42	Alternative option if the encoder cannot be connected using its ID. Page 43

5.3.3 Connecting the encoder using its ID

- ▶ Double-click **Connect the encoder** in the function menu
- ▶ The **Encoder selection** dialog opens

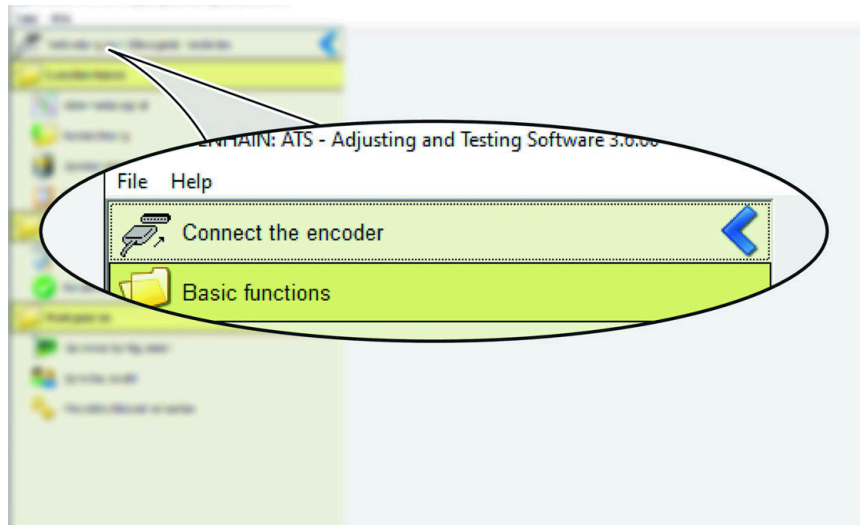

Function menu

- ▶ Enter the product ID in the **ID number** field
- ▶ The determined encoder parameters are shown in the **Encoder data** field.
- ▶ Click **Connect**
- ▶ The connection to the encoder is established.

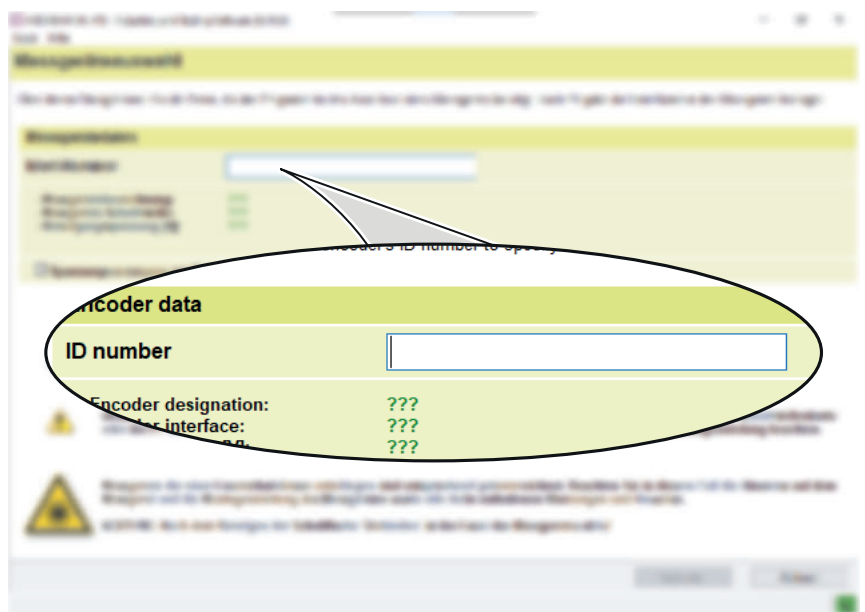

Encoder selection dialog

- ▶ **LIC 411, LIC 419x scanning head:** The **Function menu** opens.
- Next step:** "Mounting the LIC 411 or LIC 419x scanning head", Page 47
- ▶ **LIC 413 scanning head:** The **position display** opens.
- Next step:** "Mounting the LIC 413 scanning head", Page 49
- ▶ **LIC 413 scanning head in bus operation:** The **overview of bus addresses** opens.
- Next step:** "Mounting the LIC 413 scanning head in bus operation", Page 52



If you cannot connect the encoder using its ID, proceed as described in the "**Connecting the encoder manually**" chapter.

5.3.4 Connecting the encoder manually

- ▶ Double-click **Connect the encoder** in the function menu
- > The **Encoder selection** dialog opens.

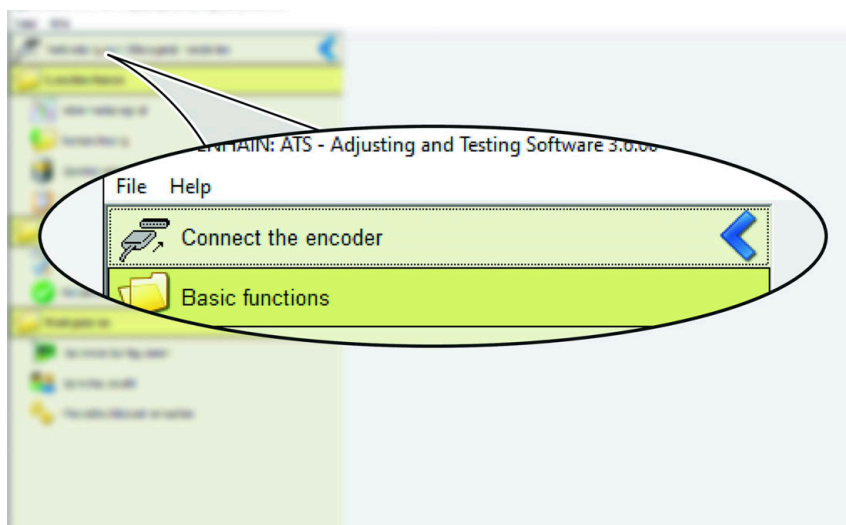

Function menu

- ▶ Click **Manual Settings**
- > The **Encoder selection** dialog opens.

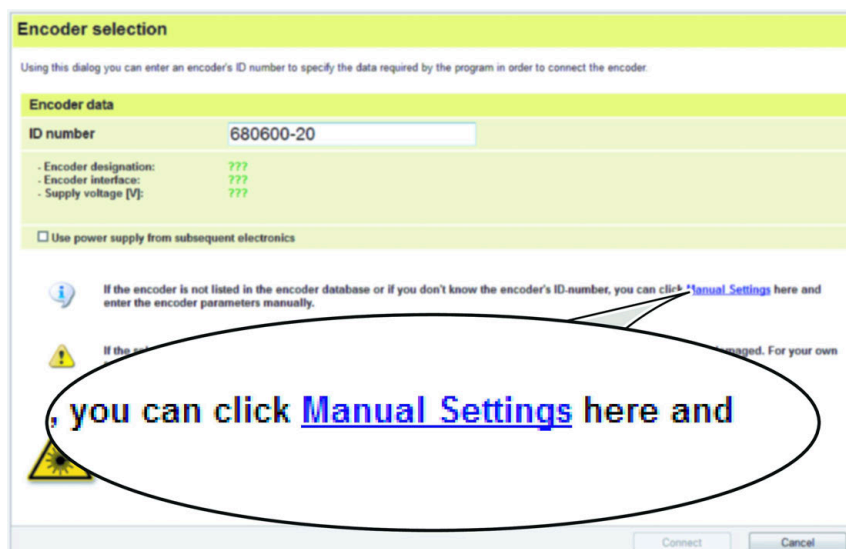

Encoder selection dialog

- ▶ Follow the safety instructions
- ▶ Click **Next**
- > The **Encoder selection** dialog opens.

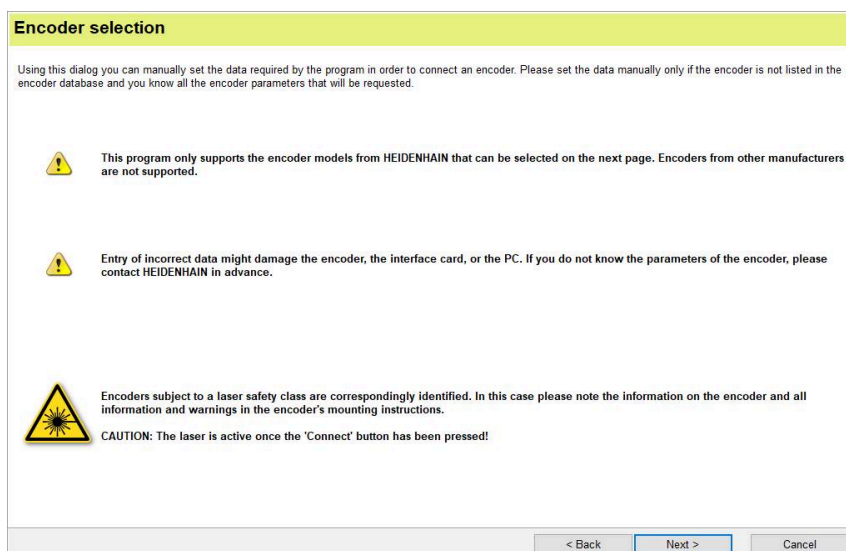

Encoder selection dialog



For more information on the supply voltage and interfaces, refer to the **Exposed Linear Encoders** brochure.

- ▶ www.heidenhain.com/documentation
- ▶ Enter the document ID **208960**

- ▶ Select the permissible encoder supply voltage in the **Encoder supply voltage** section
- ▶ If necessary, deactivate **Adjust voltage over sensor lines**
- ▶ Select the interface type in the **Encoder interface** section
If the EnDat 3 interface is selected, the mounting code is entered automatically. Click **Next** and continue with the chapter "Mounting the LIC 413 scanning head" or "Mounting the LIC 413 scanning head in bus operation".

If a different interface was selected:

- ▶ Click **Mounting code**
- ▶ The **Entry of ATS code** message appears.
- ▶ Click **OK**
- ▶ The **Encoder selection** dialog with the mounting code opens.

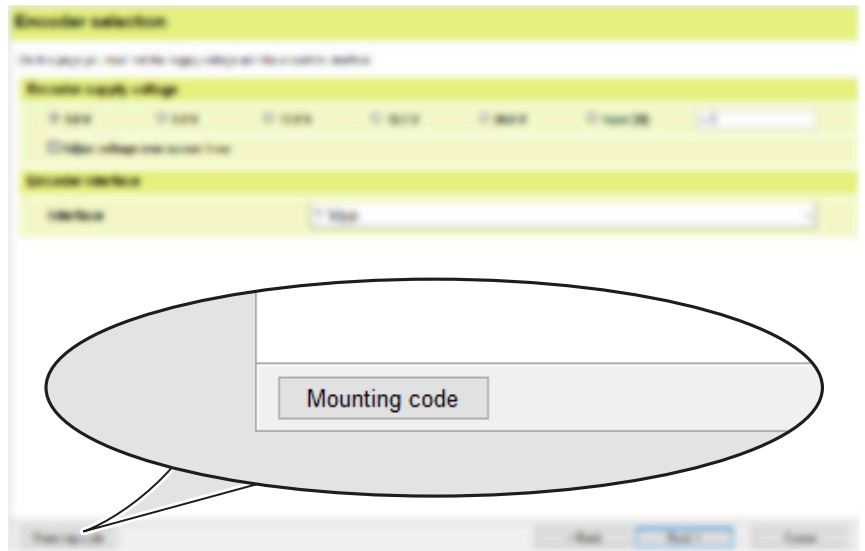

Encoder selection dialog

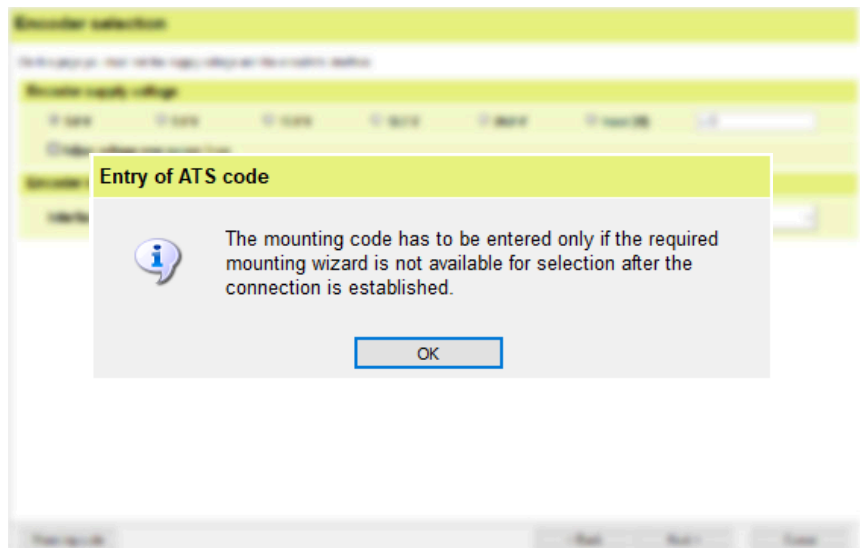

The **Entry of ATS code** note

- ▶ For the **Mounting code**, enter the value:
LIC 411: E001-A005 LIC 413: E003-A005 LIC 419x: E002-A005
- ▶ Click **Next**
- ▶ The **Encoder selection** dialog with the encoder data opens.

Encoder selection dialog with the mounting code

NOTICE

Property damage due to incorrect data settings!

Incorrect data settings can cause damage to the interface card or the PC.

- ▶ Before connecting the encoder, check the encoder data

Encoder interface:	EnDat22	EnDat3
Supply voltage [V]:	5.0	12.0
Voltage adjustment:	No	No

- ▶ Click **Connect**
- ▶ The connection to the encoder is established.

The **Encoder selection** dialog with the encoder data

- ▶ **LIC 411, LIC 419x scanning head:** The **Function menu** opens.
- Next step:** "Mounting the LIC 411 or LIC 419x scanning head", Page 47
- ▶ **LIC 413 scanning head:** The **position display** opens.
- Next step:** "Mounting the LIC 413 scanning head", Page 49
- ▶ **LIC 413 scanning head in bus operation:** The **overview of bus addresses** opens.
- Next step:** "Mounting the LIC 413 scanning head in bus operation", Page 52

5.4 Mounting the scanning head

5.4.1 Selecting the scanning head

Scanning head variants		
LIC 411, LIC 419x	LIC 413	LIC 413 in bus operation
Scanning head with the EnDat 2.2, Fanuc, Mitsubishi, Panasonic or Yaskawa interface Page 47	Scanning head with the EnDat 3 interface Page 49	Scanning head with the EnDat 3 interface in bus operation Page 52

5.4.2 Mounting the LIC 411 or LIC 419x scanning head

Using the mounting wizard

- ▶ Double-click **LIC mounting**
- ▶ The **LIC mounting wizard** opens.

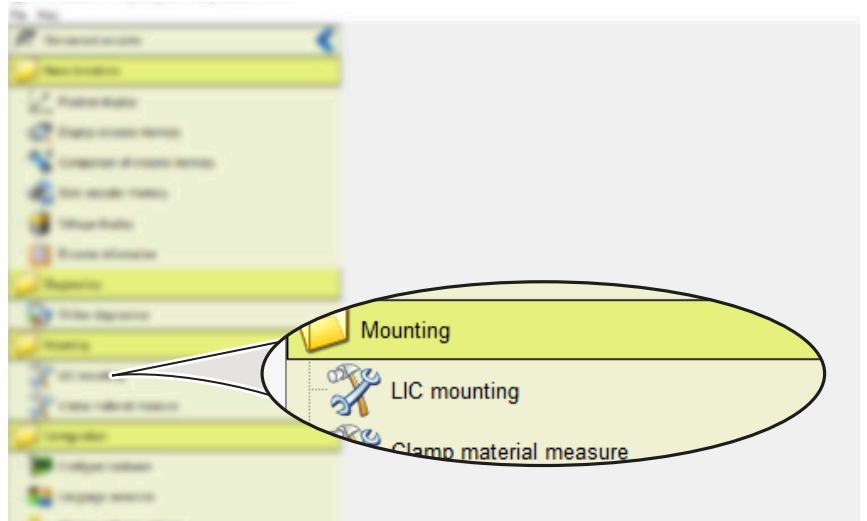

Function menu

Adjust the scanning head in the area of the midpoint of the measuring length.

- ▶ Set the absolute track to the maximum attainable bar length by slightly turning the scanning head
- ▶ Tighten the screws with the specified torque
- ▶ Click **Next**
- ▶ The **Step 2: Verify mounting** dialog opens.

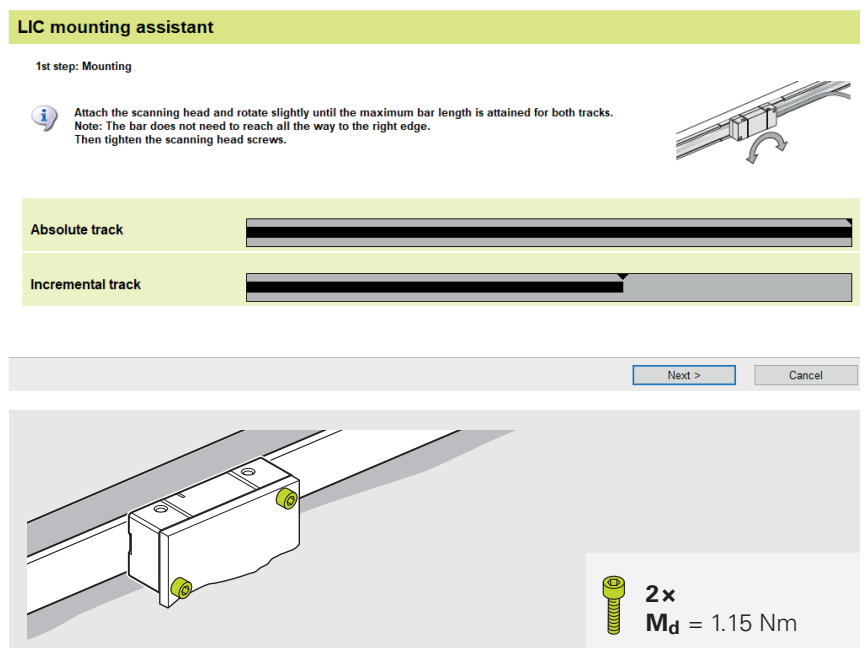

i If an error message occurs, it is because the maximum incremental signal was not achieved.

- ▶ Repeat the installation

- ▶ Traverse the scanning head over the entire measuring length
- ▶ Ensure that the minimum markers remain within the green ranges

i If the green ranges are not reached or if strong signal fluctuations occur over the entire measuring length, check the mounting tolerances and inspect for contamination.

- ▶ Click **Exit**
- ▶ The **Installation successful** message appears.

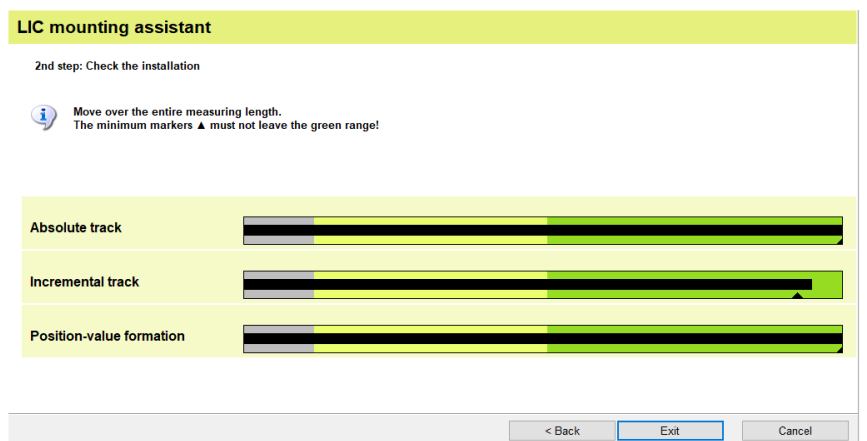

- ▶ Click **OK**
- > The **Function menu** opens.
- > Mounting was successfully concluded.

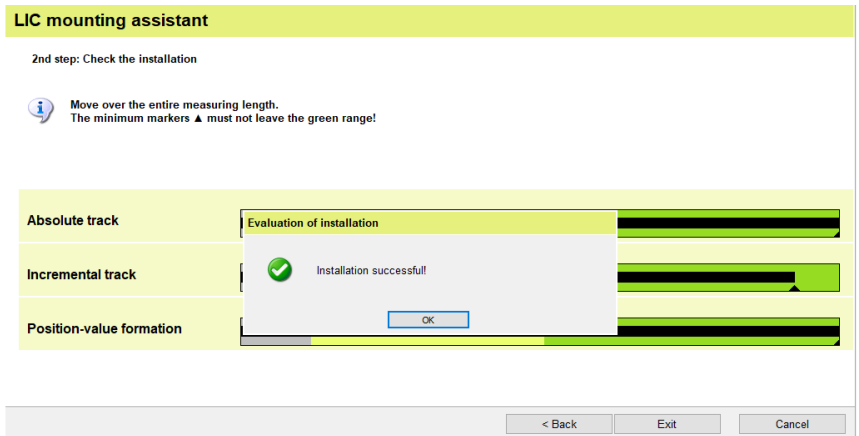

- ▶ Double-click **Disconnect encoder**

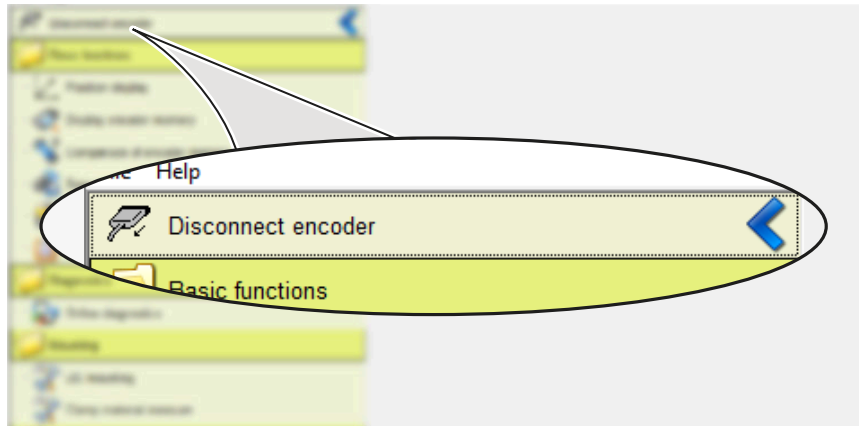

Next step "Final steps", Page 55

5.4.3 Mounting the LIC 413 scanning head

Using the mounting wizard

- ▶ Click **Wizards**

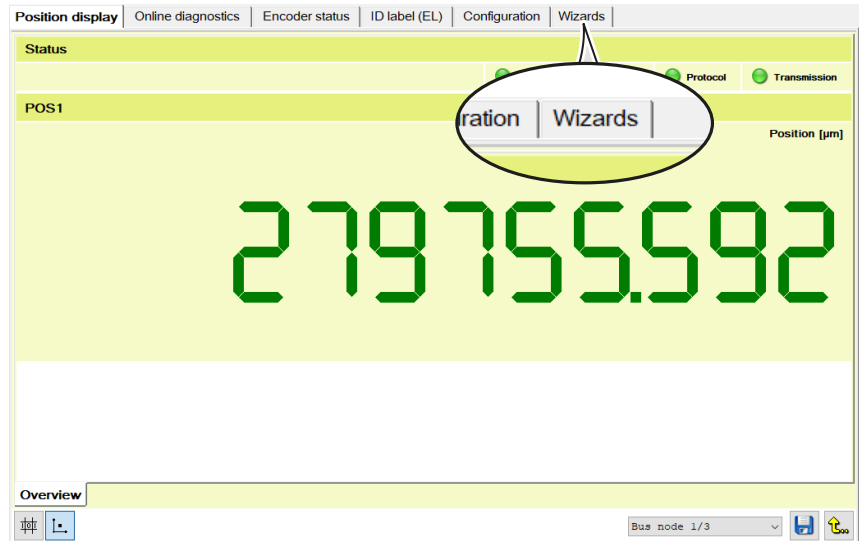

- ▶ Click **LIC mounting wizard**
- ▶ The **Step 1: Mounting** dialog opens.

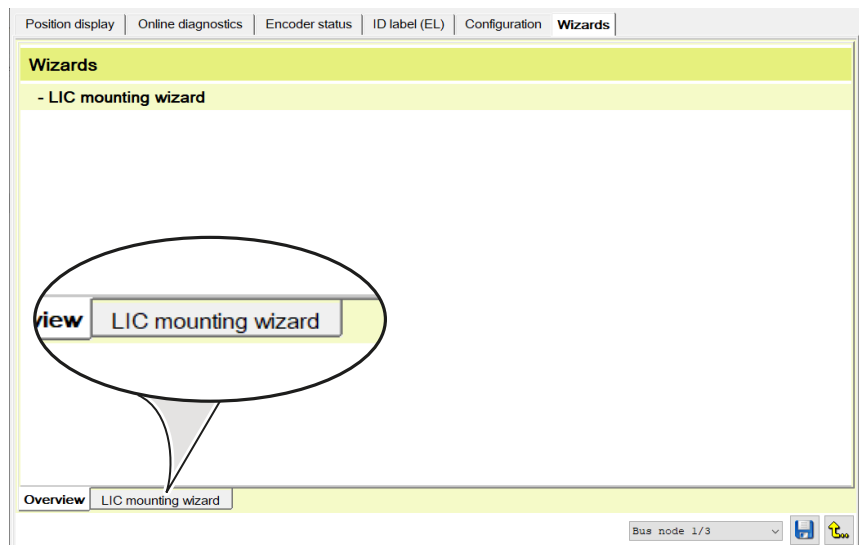

Adjust the scanning head in the area of the midpoint of the measuring length.

- ▶ Set the absolute track to the maximum attainable bar length by slightly turning the scanning head
- ▶ Tighten the screws with the specified torque
- ▶ Click **Next**
- ▶ The **Step 2: Verify mounting** dialog opens.

i If an error message occurs, it is because the maximum incremental signal was not achieved.

- ▶ Repeat the installation

- ▶ Traverse the scanning head over the entire measuring length
- ▶ Ensure that the minimum markers remain within the green ranges

i If the green ranges are not reached or if strong signal fluctuations occur over the entire measuring length, check the mounting tolerances and inspect for contamination.

- ▶ Click **Next**
- ▶ The **Installation successful** message appears.

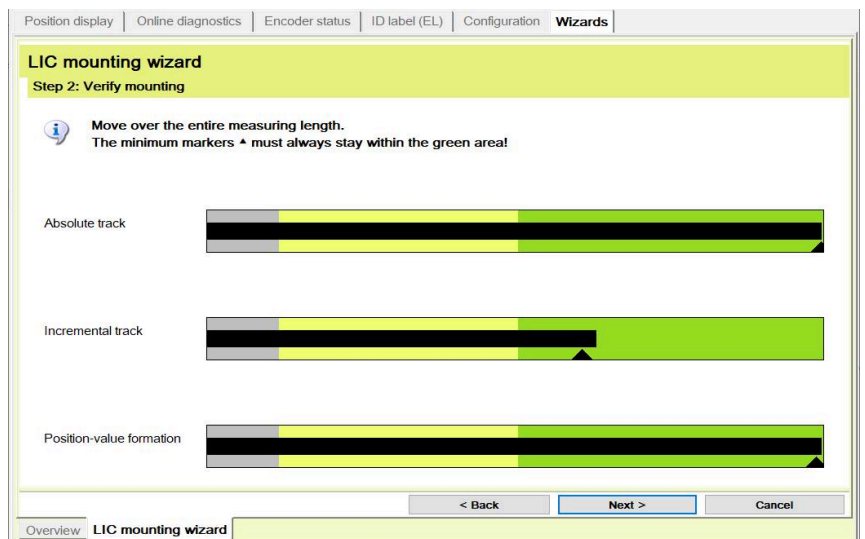
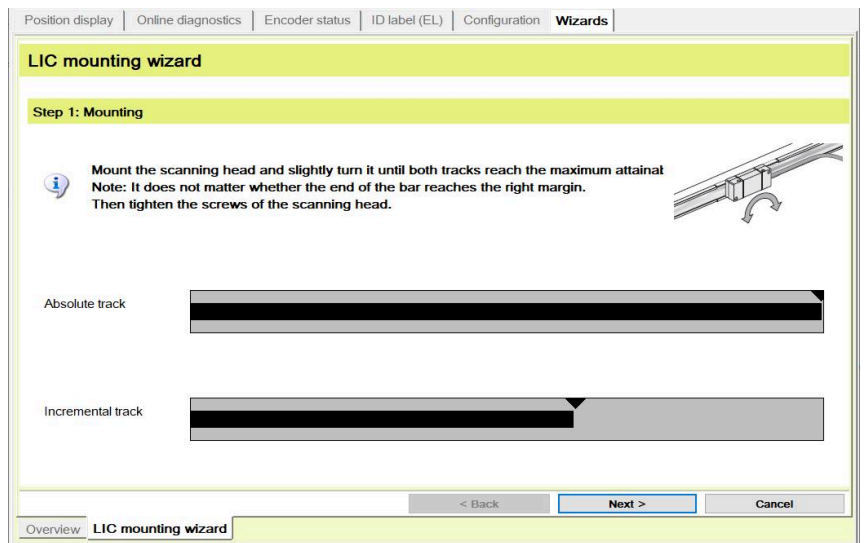

- ▶ Click **Exit**
- > The **Function menu** opens.
- > Mounting was successfully concluded.

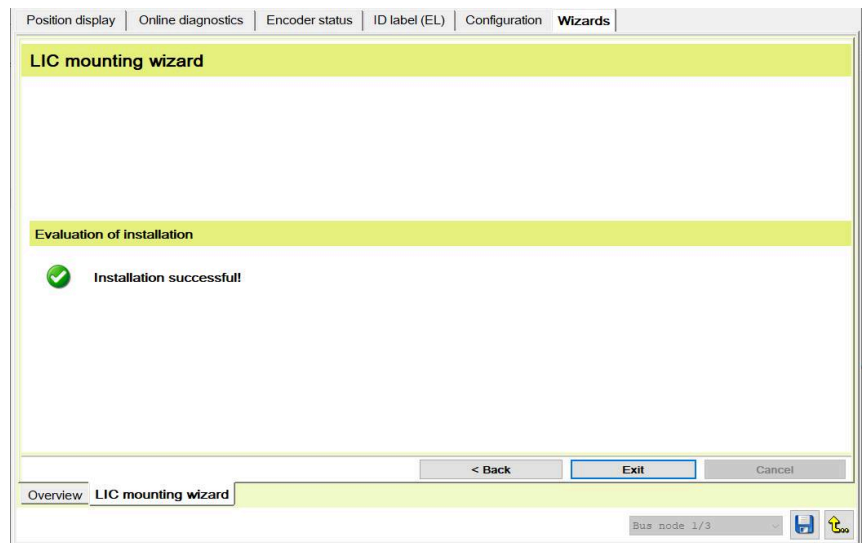

- ▶ Double-click **Disconnect encoder**

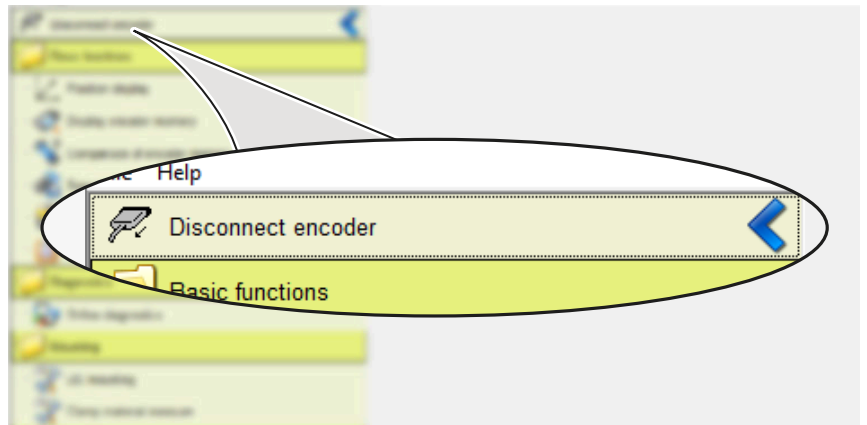

Next step "Final steps", Page 55

5.4.4 Mounting the LIC 413 scanning head in bus operation

Using the mounting wizard

- ▶ Click **OK**
- ▶ The **position display** appears.

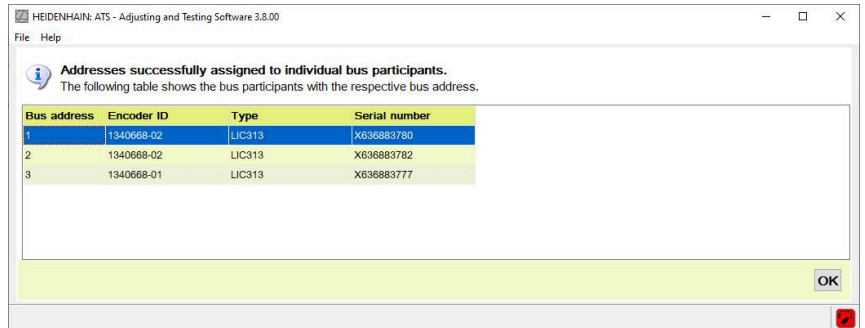

- ▶ Click **Wizards**

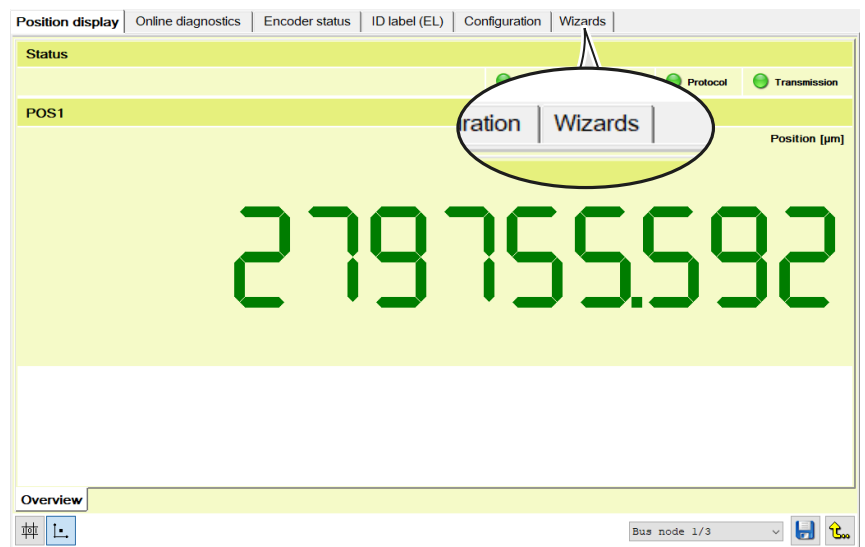

- ▶ Select **Bus node 1/3**

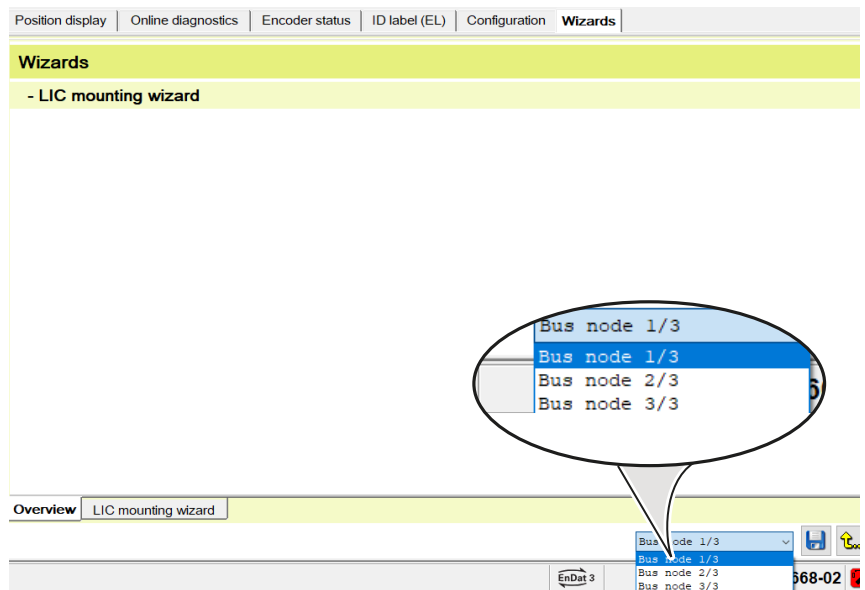

- ▶ Click **LIC mounting wizard**
- ▶ The **Step 1: Mounting** dialog opens.

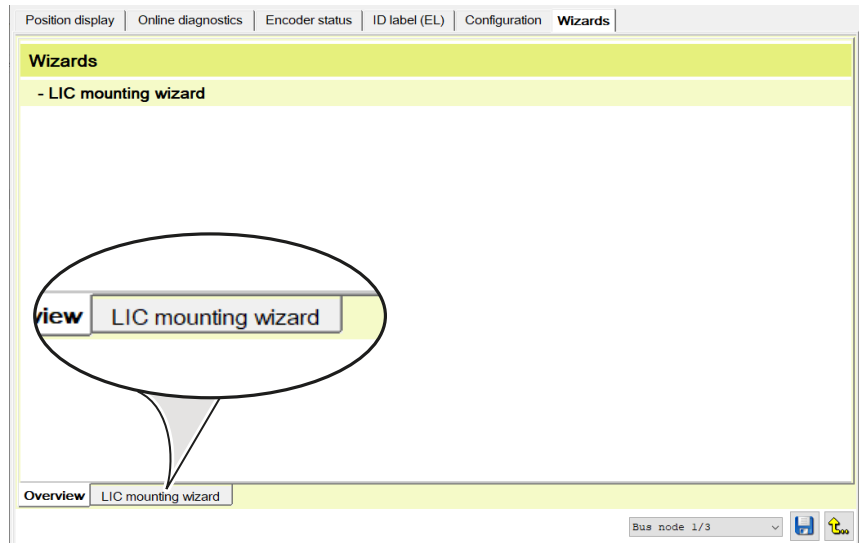

Adjust the scanning head in the area of the midpoint of the measuring length.

- ▶ Set the absolute track to the maximum attainable bar length by slightly turning the scanning head
- ▶ Tighten the screws with the specified torque
- ▶ Click **Next**
- ▶ The **Step 2: Verify mounting** dialog opens.

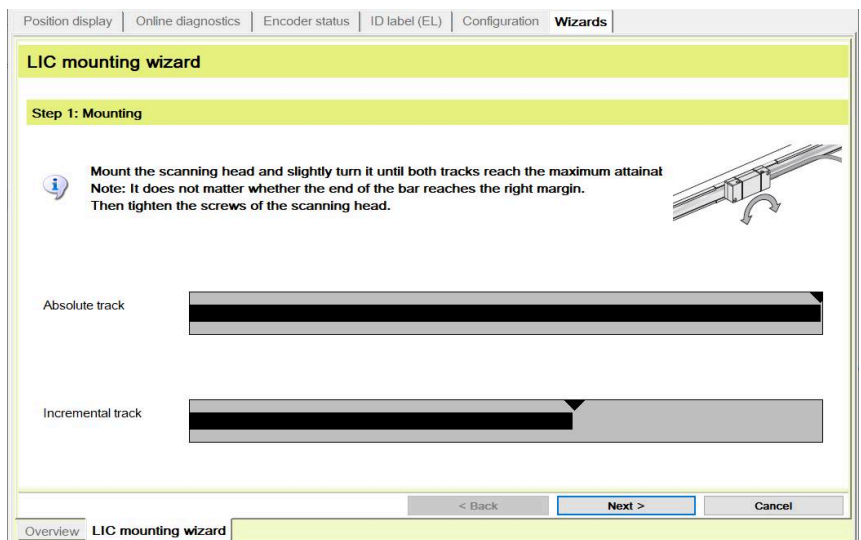

If an error message occurs, it is because the maximum incremental signal was not achieved.

- ▶ Repeat the installation



- ▶ Traverse the scanning head over the entire measuring length
- ▶ Ensure that the minimum markers remain within the green ranges

i If the green ranges are not reached or if strong signal fluctuations occur over the entire measuring length, check the mounting tolerances and inspect for contamination.

- ▶ Click **Next**
- ▶ The **Installation successful** message appears.
- ▶ Click **Exit**
- ▶ The **Function menu** opens.
- ▶ Mounting was successfully concluded.

- ▶ Follow the same procedure for **Bus node 2/3** and **Bus node 3/3**
- ▶ Double-click **Disconnect encoder**

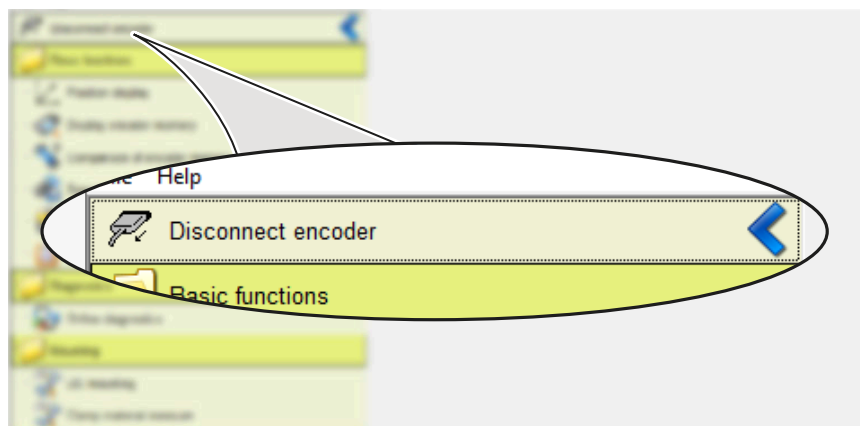
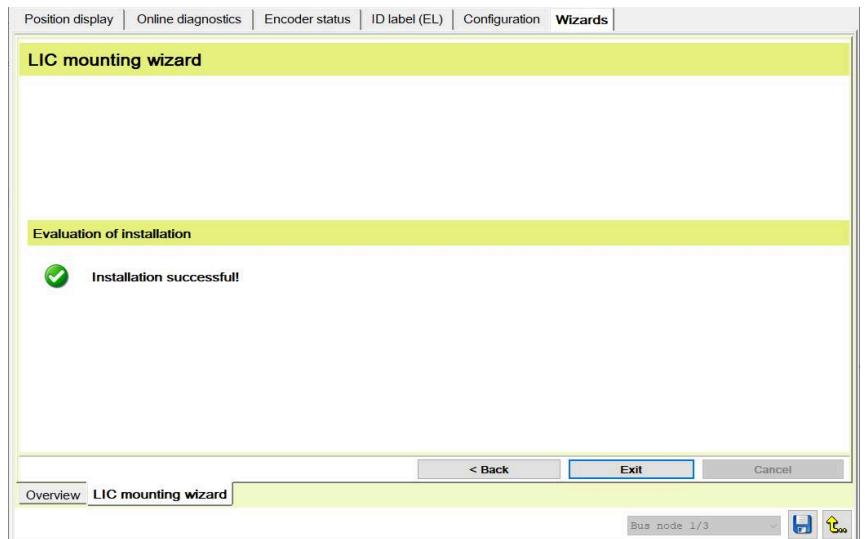
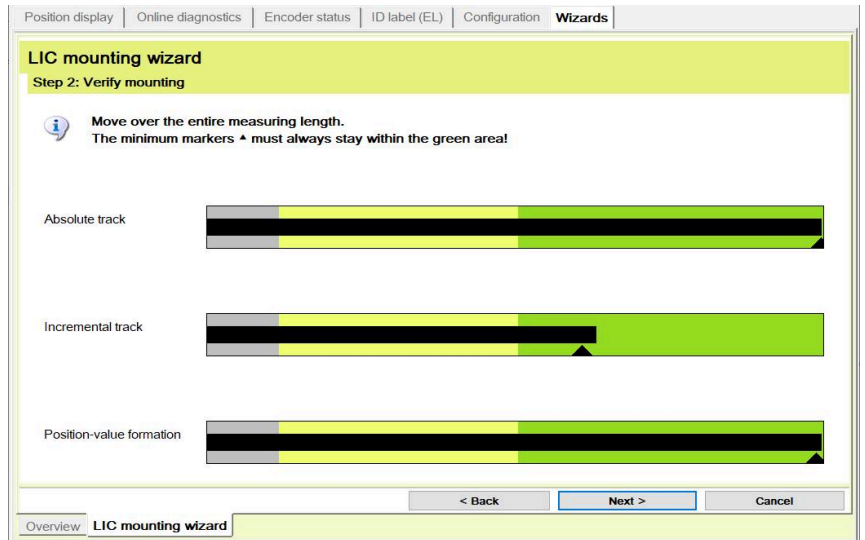

Next step "Final steps", Page 55

6 Final steps

6.1 Tensioning the scale tape

Use the Adjusting and Testing Software to tension the scale tape.

Tensioning variants

Tension the scale tape by using the **Clamp material measure** menu item

Page 56

Tension the scale tape by using the **Position display** menu item

Page 60

6.1.1 Tensioning the scale tape by using the Clamp material measure menu item

NOTICE

The **Clamp material measure** menu item for tensioning the scale tape is available with ATS version 3.8.01 and later. HEIDENHAIN recommends using the latest ATS version.

The ATS software is available for download free of charge from www.heidenhain.com/service/downloads/software/.

- ▶ Select **Clamp material measure**

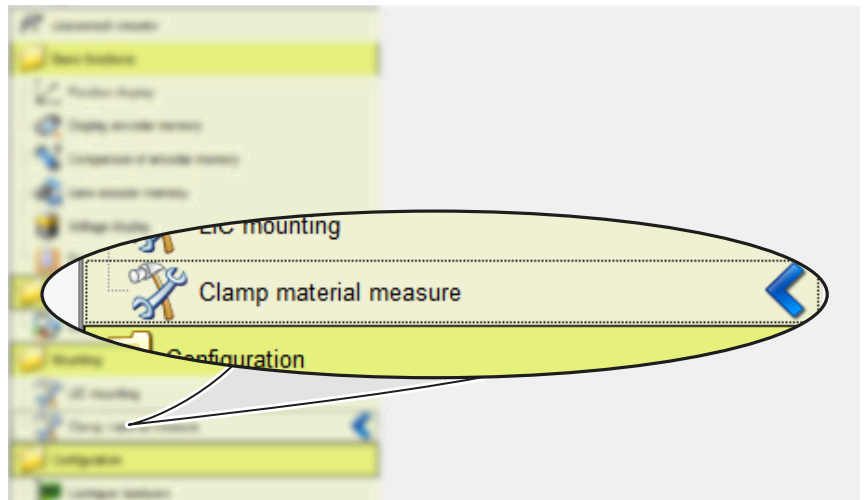

- ▶ Tension the scale tape by 50 μm .
- ▶ Remove the tension from the scale tape

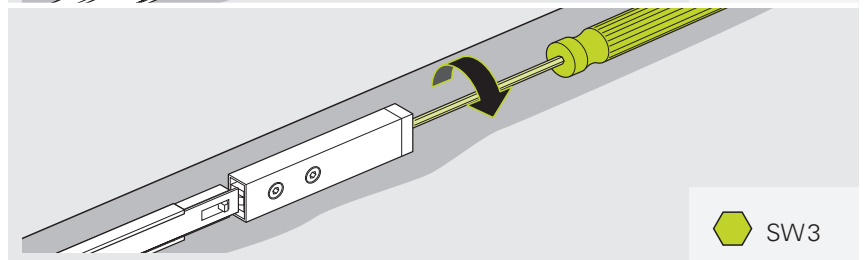
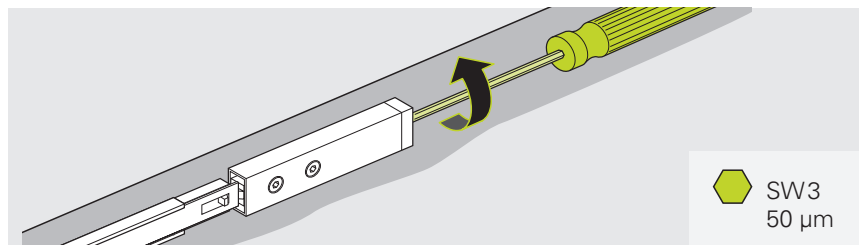

- ▶ Push the scanning head in the direction of the tensioning device up to the end of the measuring length

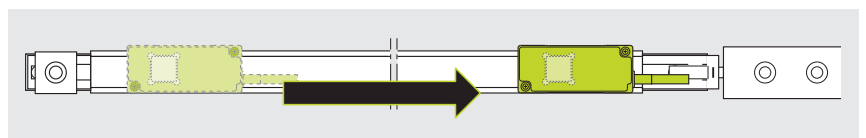

Final steps | Tensioning the scale tape | Tensioning the scale tape by using the Clamp material measure menu item

- ▶ Measure the distance (X_v) between the center of the mounting block and the center of the scanning window

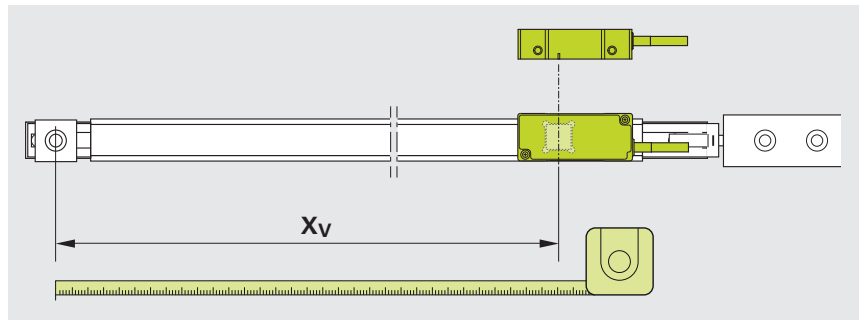

The values stated here are exemplary values.

- ▶ Replace the stated values with customer-specific parameters

- ▶ Enter the measured distance (X_v) in the field

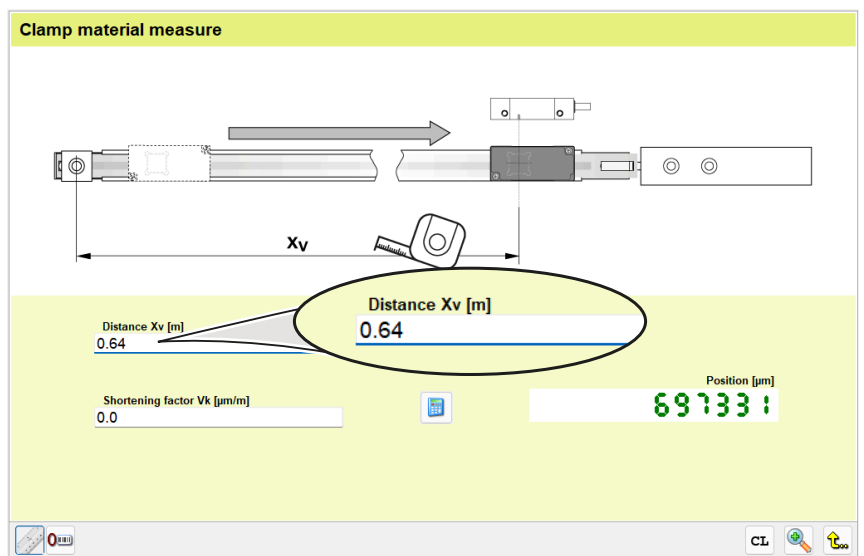

Exemplary value

- ▶ Enter the shortening factor (V_k) of the scale tape being used that you have noted down
- ▶ Calculate the clamping (tensioning) value by clicking the **Calculator** icon

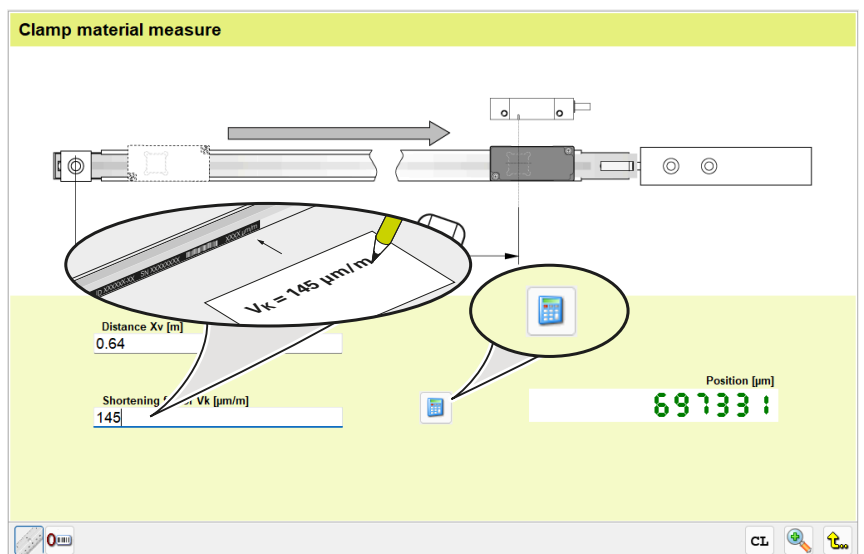

Exemplary value

- ▶ The clamping value is now displayed.

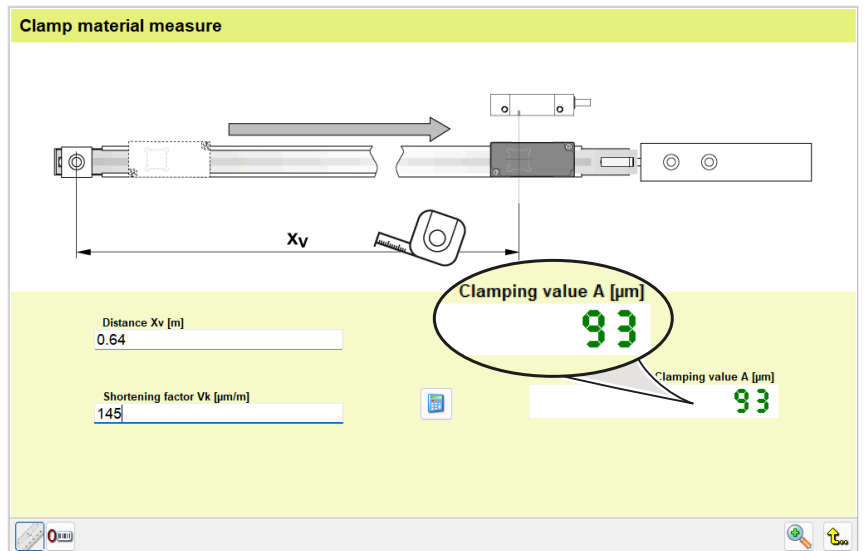

Exemplary value

- ▶ Tension the scale tape until the clamping value 0 has been reached

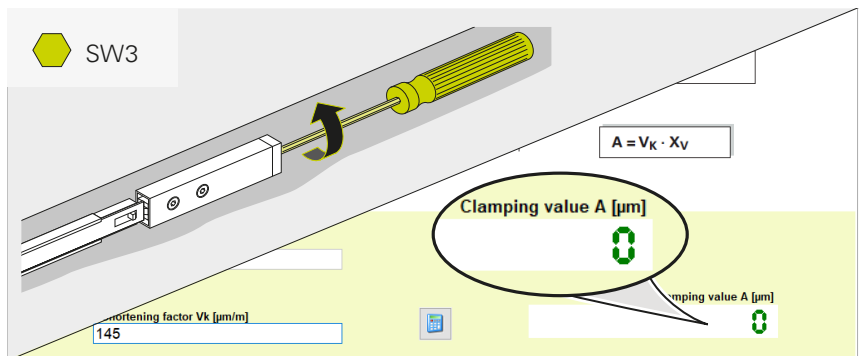

- ▶ Lightly tap the scale-tape carrier sections to release any tension
- ▶ Check the tensioning value
- ▶ If the tensioning value is not 0, re-tension the scale tape

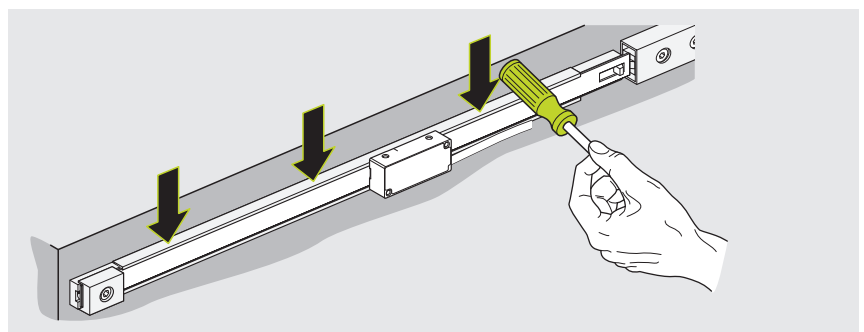

- ▶ If a fixing clamp (**Z**) is needed, fasten it with the specified torque

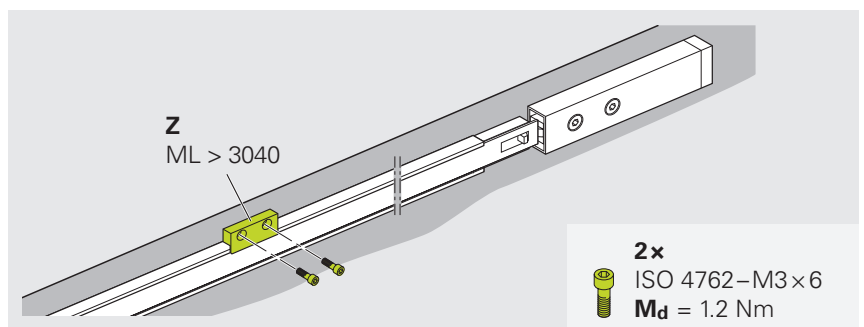

Final steps | Tensioning the scale tape | Tensioning the scale tape by using the Clamp material measure menu item

- ▶ Fasten the mounting block with the specified torque



You can leave the tensioning device mounted, or you can remove it.

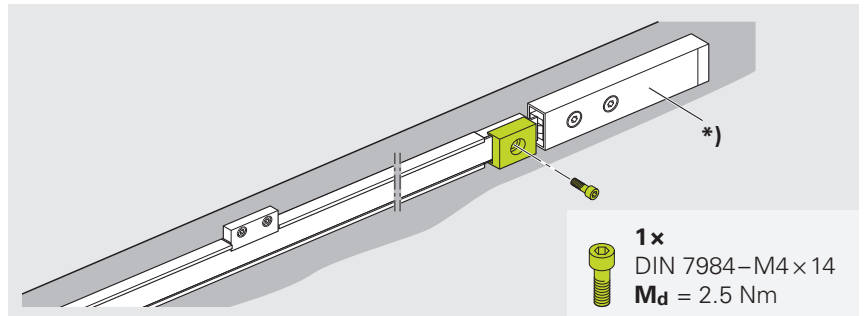

*) Tensioning device

- ▶ Return to the **Function menu**
- ▶ Double-click **Disconnect encoder**

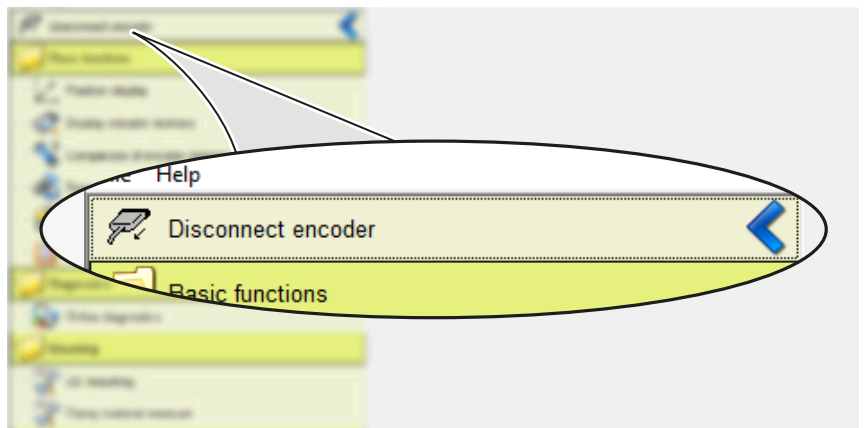

6.1.2 Tensioning the scale tape by using the Position display menu item

- ▶ Double-click **Position display**

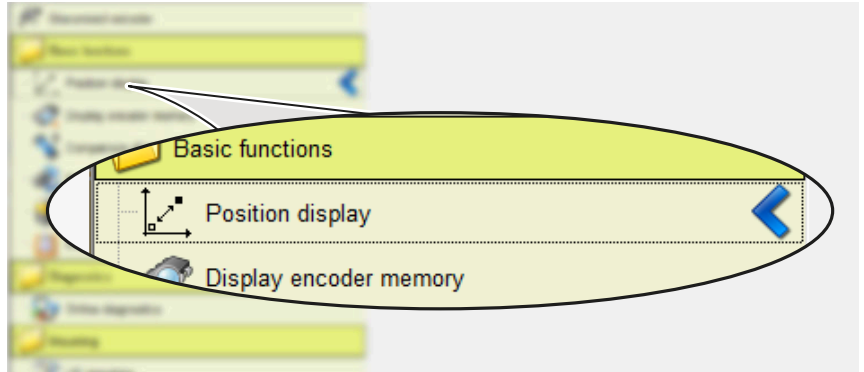

- ▶ Switch the display of the measuring steps to μm

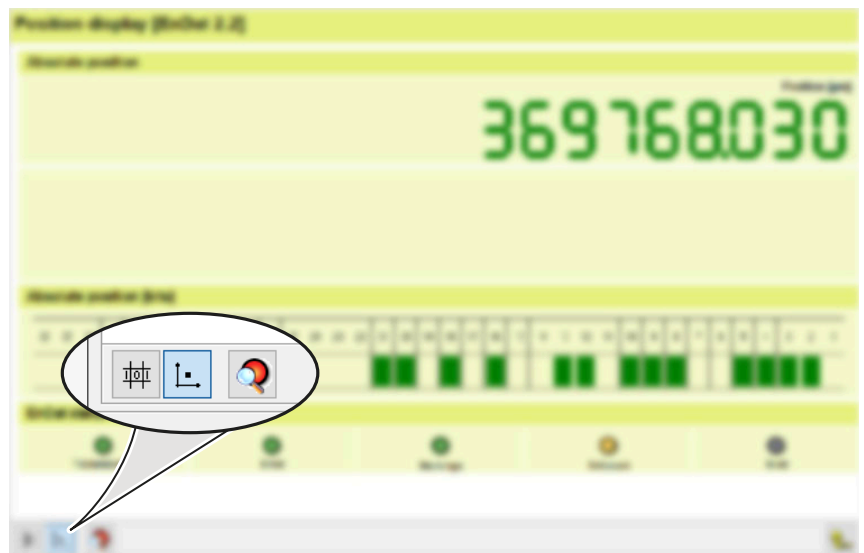

Exemplary value

- ▶ Tension the scale tape by $50\ \mu\text{m}$.
- ▶ Remove the tension from the scale tape

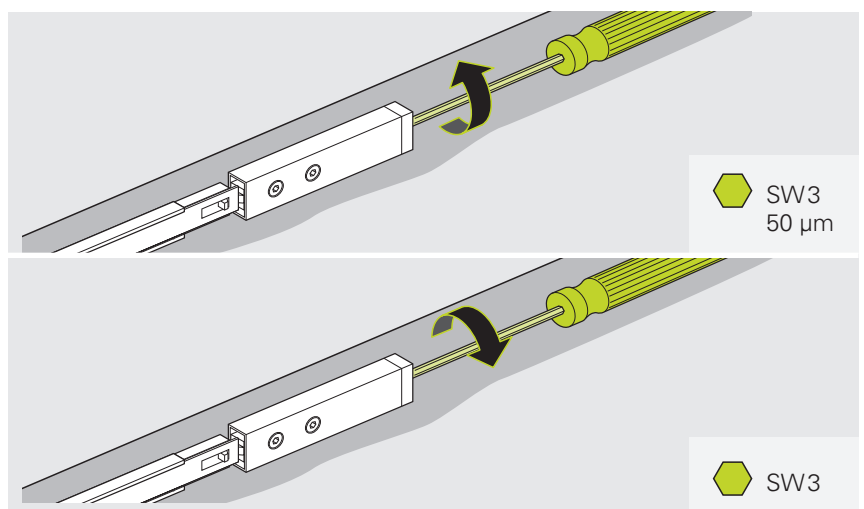

The values stated here are exemplary values.

- ▶ Replace the stated values with customer-specific parameters

Final steps | Tensioning the scale tape | Tensioning the scale tape by using the Position display menu item

- ▶ Push the scanning head in the direction of the tensioning device up to the end of the measuring length
- ▶ Measure the distance (X_V) between the center of the mounting block and the center of the scanning window and note it down

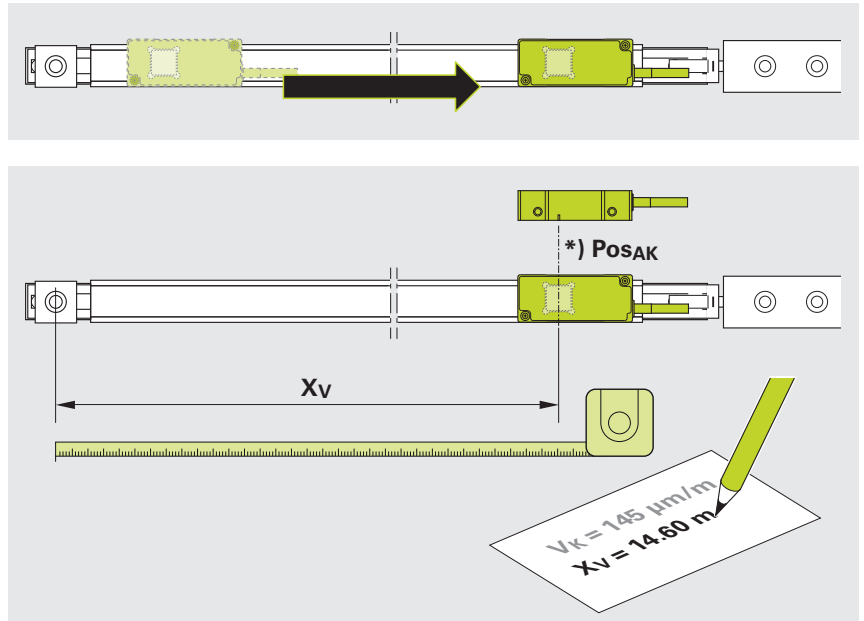

*) POS_{AK} = Position of scanning head



V_K = Used scale tape's shortening factor that you have noted down

- ▶ Calculate the length by which the scale tape must be tensioned
- ▶ Calculate the tensioning value

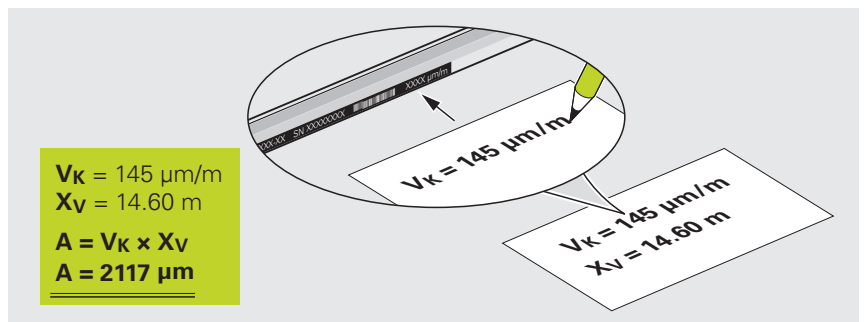

Calculation example

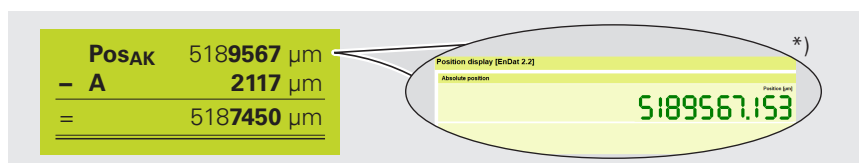

Calculation example; *) Exemplary value of the scanning head (AK) position (POS_{AK})

- ▶ Tension the scale tape until the calculated tensioning value has been reached

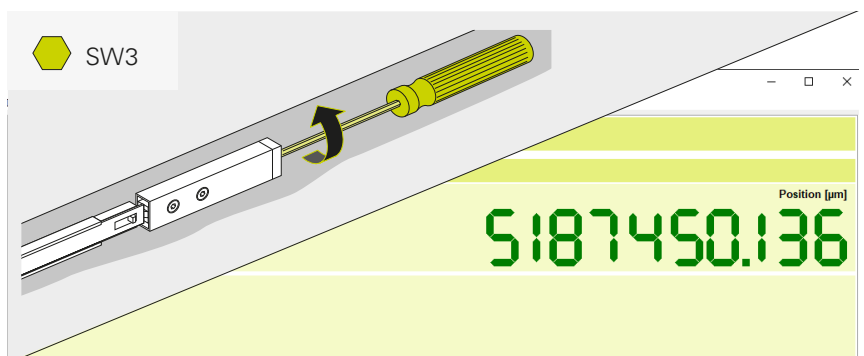

Exemplary value

- ▶ Lightly tap the scale-tape carrier sections to release any tension
- ▶ Check the absolute position
- ▶ If the absolute position differs from the calculated value, re-tension the scale tape

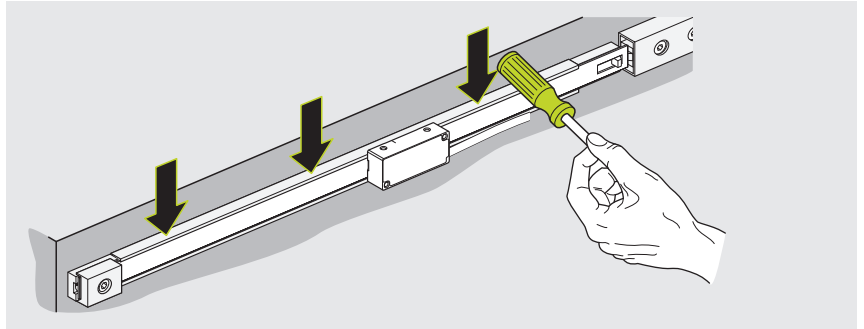

- ▶ If a fixing clamp (**Z**) is needed, fasten it with the specified torque

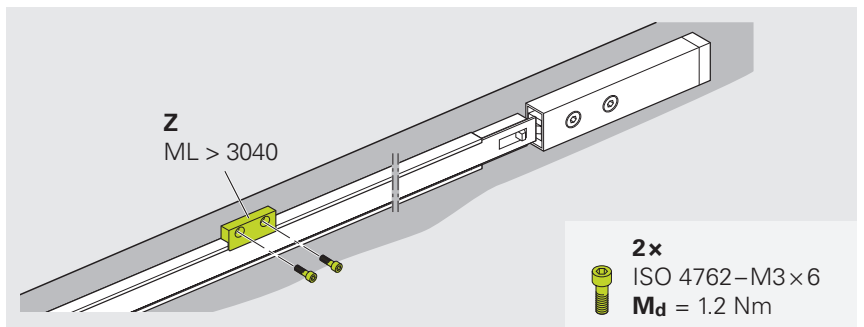

- ▶ Fasten the mounting block with the specified torque



You can leave the tensioning device mounted, or you can remove it.

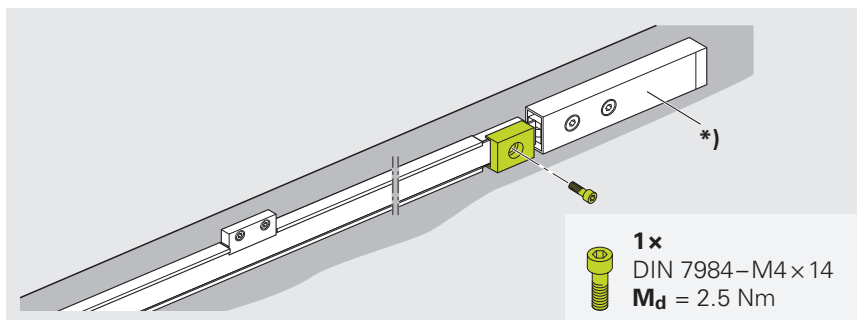

*) Tensioning device

- ▶ Return to the **Function menu**
- ▶ Double-click **Disconnect encoder**

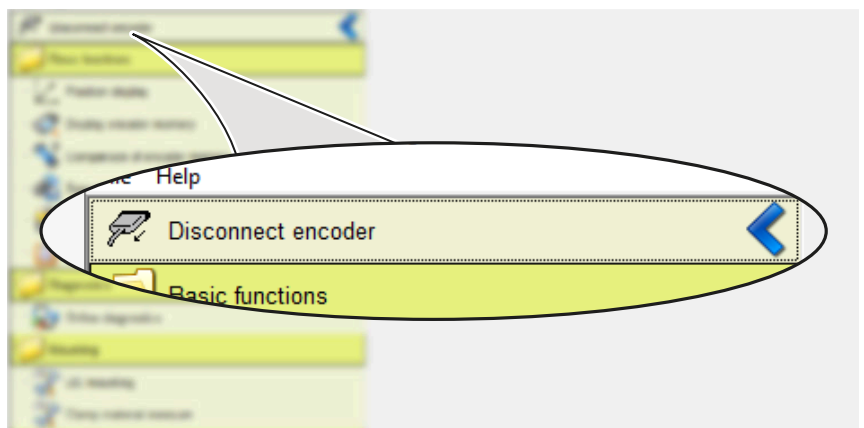

6.2 Connecting the encoder with the downstream electronics

WARNING

Danger of electric shock due to plug connections under voltage!

Connecting and disconnecting live cables and plug connections in the equipment can result in death or serious injury.

- Only connect and disconnect cables and plug connections when no current is flowing through them
- Disconnect the downstream electronics from power before connecting the product
- For cables without connectors, pay attention to the pin layout

- ▶ Connect the encoder to the downstream electronics

NOTICE

Property damage resulting from incorrect routing of the connecting cable!

Connecting cables may become damaged as a result of incorrect routing.

- ▶ Observe the maximum permissible bend radii
- ▶ Do not cross connecting cables in drag chains
- ▶ Route connecting cables professionally



For more information on the cable characteristics and cable routing, refer to the **Cables and Connectors** brochure.

- ▶ www.heidenhain.com/documentation
- ▶ Enter the document ID **1206103**



For more information on the pin layouts, refer to the **Cables and Connectors** brochure.

- ▶ www.heidenhain.com/documentation
- ▶ Enter the document ID **1206103**



For more information on sources of interference, refer to the **Interfaces of HEIDENHAIN Encoders** brochure.

- ▶ www.heidenhain.com/documentation
- ▶ Enter the document ID **1078628**

7 Removal

This chapter describes the removal of the product.

7.1 Safety precautions regarding removal

WARNING

Live plug connections!

If you disengage plug connections while the equipment is under power, this may result in fatal accidents or severe personal injury.

- ▶ Do not engage or disengage any connecting elements while the product is under power

WARNING

Moving machine parts!

Risk of injury due to moving machine parts depending on the installation location and the application

- ▶ Observe all of the machine manufacturer's notes on working on the machine, e.g., always disconnect the machine from the power supply

CAUTION

Fragile carrier material of the scale tape!

Risk of injury from splinters and sharp edges of the carrier material

- ▶ Wear protective gloves and safety goggles
- ▶ Do not bend or deform the scale tape excessively

7.2 Removing the scanning head

- ▶ Remove the scanning head in the reversed sequence of mounting. **Further information:** "Mounting the scanning head", Page 27

7.3 Disassembling the parts kit



Further information can be found in the **Disassembly Instructions**.

- ▶ www.heidenhain.com/documentation
- ▶ Enter the document ID **1185755**

HEIDENHAIN

DR. JOHANNES HEIDENHAIN GmbH

Dr.-Johannes-Heidenhain-Straße 5

83301 Traunreut, Germany

☎ +49 8669 31-0

☎ +49 8669 32-5061

info@heidenhain.de

Technical support ☎ +49 8669 32-1000

Measuring systems ☎ +49 8669 31-3104

service.ms-support@heidenhain.de

NC support ☎ +49 8669 31-3101

service.nc-support@heidenhain.de

NC programming ☎ +49 8669 31-3103

service.nc-pgm@heidenhain.de

PLC programming ☎ +49 8669 31-3102

service.plc@heidenhain.de

APP programming ☎ +49 8669 31-3106

service.app@heidenhain.de

www.heidenhain.com