

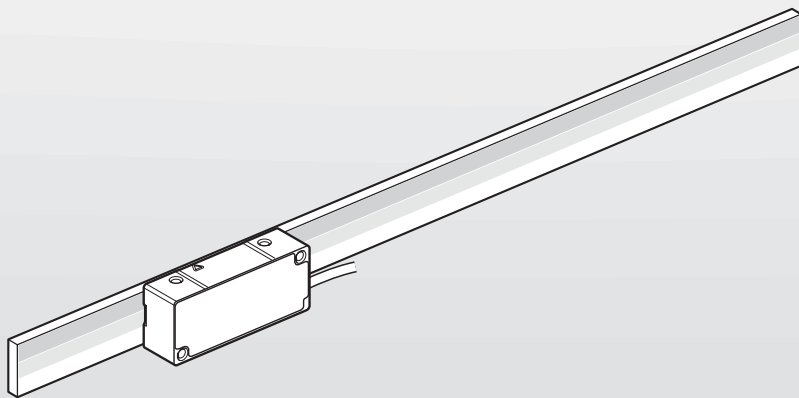

**HEIDENHAIN**



**LIC 4113**

**LIC 4133**

**LIC 4193**

Mounting Instructions

## Table of contents

<b>1</b>	<b>Basic information.....</b>	<b>4</b>
1.1	Validity of the documentation.....	4
1.2	Target groups of the Mounting Instructions.....	4
1.3	Notes on reading the documentation.....	5
1.4	Symbols and fonts used for marking text.....	6
1.5	Notes in this documentation.....	7
1.6	Units and tolerances.....	7
<b>2</b>	<b>Safety.....</b>	<b>8</b>
2.1	Personnel qualification.....	8
2.2	General safety precautions.....	8
<b>3</b>	<b>Items supplied and accessories.....</b>	<b>10</b>
3.1	Items supplied.....	10
3.1.1	Items supplied with the LIC 4003 scale.....	10
3.1.2	Items supplied: LIC 411, LIC 413, LIC 419 scanning head.....	11
3.1.3	Items supplied with the LIC 411 V, LIC 419 FV, MV, PV scanning heads.....	12
3.2	Mounting accessories.....	13
3.2.1	Accessories for mounting the linear scale.....	13
3.2.2	Accessories for mounting the scanning head.....	13
3.2.3	Accessories for fixed-point bonding.....	14
<b>4</b>	<b>Mounting.....</b>	<b>15</b>
4.1	Requirements and notes.....	15
4.2	Mounting the linear scale.....	16
4.2.1	Choosing the mounting variant.....	16
4.2.2	Variant: Mounting with adhesive film.....	17
4.2.3	Variant: Mounting with fixing clamps.....	21
4.3	Mounting the scanning head.....	27
4.3.1	Selecting the product variant.....	27
4.3.2	Mounting the LIC 411, LIC 413, LIC 419 scanning heads.....	28
4.3.3	Mounting the LIC 411 V, 419 FV, MV, PV scanning heads.....	41

<b>5</b>	<b>Adjustment and diagnosis.....</b>	<b>51</b>
5.1	Requirements and notes.....	51
5.2	Continuity check.....	51
5.2.1	Measuring the electrical resistance.....	51
5.3	Connecting the encoder to the ATS.....	52
5.3.1	Connecting the encoder.....	52
5.3.2	Selecting the connection.....	52
5.3.3	Connecting the encoder using its ID.....	53
5.3.4	Connecting the encoder manually.....	54
5.4	Mounting the scanning head.....	57
5.4.1	Selecting the scanning head.....	57
5.4.2	Mounting the LIC 411 or LIC 419x scanning head.....	58
5.4.3	Mounting the LIC 413 scanning head.....	60
5.4.4	Mounting the LIC 413 scanning head in bus operation.....	63
<b>6</b>	<b>Final steps.....</b>	<b>66</b>
6.1	Connecting the encoder with the downstream electronics.....	66
<b>7</b>	<b>Removal.....</b>	<b>67</b>
7.1	Safety precautions regarding removal.....	67
7.2	Removing the scanning head.....	67
7.3	Removing the scale.....	67

## 1 Basic information

This chapter contains information about the product and the Mounting Instructions.

### 1.1 Validity of the documentation

These Mounting Instructions apply to products of the LIC 4113, LIC 4133, LIC 4193 series.

- Before using the documentation, check whether the documentation and product model match. The designation of the product is printed on the ID label.

#### ID label

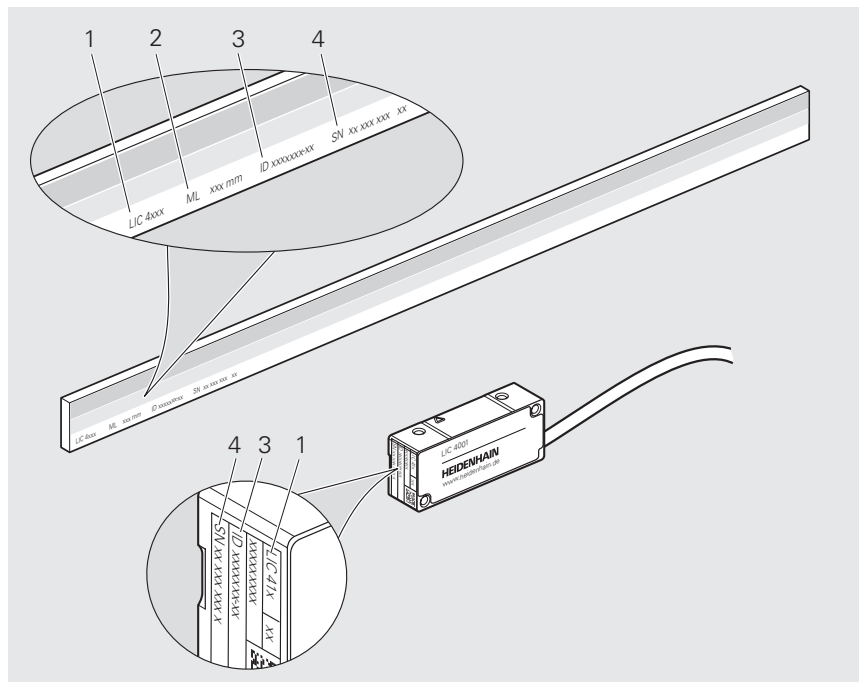

ID label with legend

- 1 Product name
- 2 Measuring length (ML)
- 3 Part number (ID)
- 4 Serial number (SN)

### 1.2 Target groups of the Mounting Instructions

The Mounting Instructions must be read and observed by every person who performs any of the following tasks:

- Design
- Mounting
- Removal

## 1.3 Notes on reading the documentation

### WARNING

#### **Fatal accidents, personal injury or property damage caused by non-compliance with the documentation!**

Failure to comply with the documentation may result in fatal accidents, personal injury or property damage.

- ▶ Read the documentation carefully from beginning to end
- ▶ Keep the documentation for future reference

The following table lists the various parts of the documentation in their order of reading priority.

Document type	Description
Addendum	An Addendum supplements or supersedes the corresponding contents of the Operating Instructions and, if applicable, of the Mounting Instructions. If an Addendum is included in the shipment, it has the highest priority for reading. All other documentation content retains its validity.
Operating Instructions	The Operating Instructions contain all of the information and safety instructions for the proper and intended operation of the device. The Operating Instructions (English language version) are included in delivery and can also be downloaded in other languages from <b><a href="http://www.heidenhain.com/documentation">www.heidenhain.com/documentation</a></b> . The Operating Instructions must be read prior to initial operation of the product. The Operating Instructions have the second highest priority for reading.
Mounting Instructions	The Mounting Instructions contain all the information and safety precautions needed for the proper mounting and installation of a product. The Mounting Instructions are not included in delivery and must be downloaded from <b><a href="http://www.heidenhain.com/documentation">www.heidenhain.com/documentation</a></b> . The Mounting Instructions have the third highest priority for reading.

#### **Have you found any errors or would you like to suggest changes?**

We are continuously striving to improve our documentation for you. Please help us by sending your suggestions to the following e-mail address:

**[userdoc@heidenhain.de](mailto:userdoc@heidenhain.de)**

## 1.4 Symbols and fonts used for marking text

In these instructions the following symbols and fonts are used for marking text:

Format	Meaning
▶ ...	Identifies an action and the result of this action
> ...	Example: ▶ Tilt the shipping brace to remove it <b>(c)</b> > The shipping brace has been removed now
■ ...	Identifies an item of a list
■ ...	Example: ■ Solid contaminants: class 3 ■ Max. pressure dew point: class 4
<b>Bold</b>	Identifies elements in figures and illustrations, such as positions, dimensions and worksteps Example: <b>S</b> marks the beginning of the measuring length <b>(ML)</b> .

## 1.5 Notes in this documentation

### Safety precautions

Precautionary statements warn of hazards in handling the product and provide information on their prevention. Precautionary statements are classified by hazard severity and divided into the following groups:

#### DANGER

**Danger** indicates hazards for persons. If you do not follow the avoidance instructions, the hazard **will result in death or severe injury**.

#### WARNING

**Warning** indicates hazards for persons. If you do not follow the avoidance instructions, the hazard **could result in death or serious injury**.

#### CAUTION

**Caution** indicates hazards for persons. If you do not follow the avoidance instructions, the hazard **could result in minor or moderate injury**.

#### NOTICE

**Notice** indicates danger to material or data. If you do not follow the avoidance instructions, the hazard **could result in property damage**.

### Informational notes

Informational notes ensure reliable and efficient operation of the product. Informational notes are divided into the following groups:



The information symbol indicates a **tip**.  
A tip provides important additional or supplementary information.



The book symbol indicates a **cross reference**.  
A cross reference leads to external documentation, for example: further documentation from HEIDENHAIN or another supplier.

## 1.6 Units and tolerances

Unless otherwise specified, the dimensions stated in these Mounting Instructions are given in millimeters.

Unless otherwise specified, the tolerances stated in these Mounting Instructions conform to ISO 8015 and ISO 2768 standards.

mm



Tolerancing ISO 8015  
ISO 2768:1989-mH  
≤ 6 mm: ±0.2 mm

## 2 Safety

This chapter provides important safety information needed for the proper mounting and installation of the product.

### 2.1 Personnel qualification

Mounting, initial configuration and removal must be conducted by a qualified specialist under compliance with local safety regulations.

### 2.2 General safety precautions

#### WARNING

##### **Danger of electric shock due to connection to unsuitable downstream electronics!**

If you connect unsuitable downstream electronics to the product, fatal accidents or severe personal injuries can occur.

- ▶ Connect the product only to downstream electronics whose supply voltage comes from PELV systems

#### WARNING

##### **Live plug connections!**

If you disengage plug connections while the equipment is under power, this may result in fatal accidents or severe personal injury.

- ▶ Do not engage or disengage any connecting elements while the product is under power

#### WARNING

##### **Risk of injury from damaged or worn components!**

Safety functions can fail if damaged or worn components are installed. Failed safety functions can result in death or serious injury.

- ▶ Inspect the component for damage
- ▶ Do not use any damaged or worn components
- ▶ In case of replacement, repair the thread
- ▶ Use new screws, spring pins and nuts
- ▶ Secure screws and nuts with suitable material-bonding anti-rotation lock

#### NOTICE

##### **Property damage due to mechanical stress!**

- ▶ Do not drop the product or subject it to major vibration
- ▶ Do not expose the product to mechanical stress
- ▶ Do not change the physical structure of the product

**NOTICE****Property damage due to electrical stress!**

- ▶ Do not engage or disengage any connecting elements while the product is under power
- ▶ Do not touch the contacts of the plug connections

**NOTICE****Electrostatic discharge (ESD)!**

This product contains electrostatically sensitive components that can be destroyed by electrostatic discharge (ESD).



- ▶ It is essential to observe the safety precautions for handling ESD-sensitive components
- ▶ Never touch connector pins without ensuring proper grounding
- ▶ Wear a grounded ESD wristband when handling the connections of the product

### 3 Items supplied and accessories

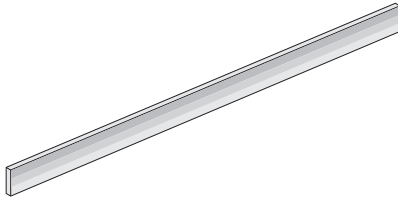
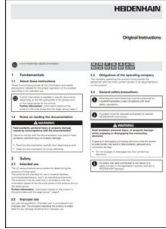

This chapter contains information on the items supplied and the available product accessories.

#### 3.1 Items supplied

##### 3.1.1 Items supplied with the LIC 4003 scale

Component	Figure
Linear scale	
Operating Instructions	
Quality Inspection Document	

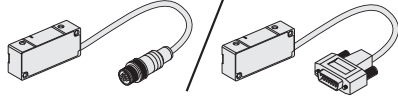
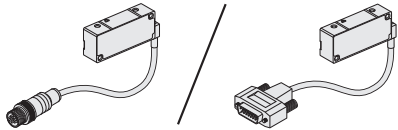
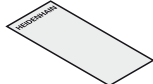
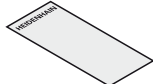
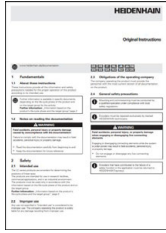
### 3.1.2 Items supplied: LIC 411, LIC 413, LIC 419 scanning head

Component	Figure
Scanning head	
or Scanning head with angled cable outlet	
Spacer shim 0.15 mm (not needed)	
Spacer shim 0.75 mm	
Operating Instructions	
Manufacturer's Inspection Document	

### 3.1.3 Items supplied with the LIC 411 V, LIC 419 FV, MV, PV scanning heads

#### NOTICE

#### Contamination due to improper opening of the packaging!



All vacuum devices are packaged in two layers of film

**Film (1):** vacuum

**Film (2):** flooded with nitrogen

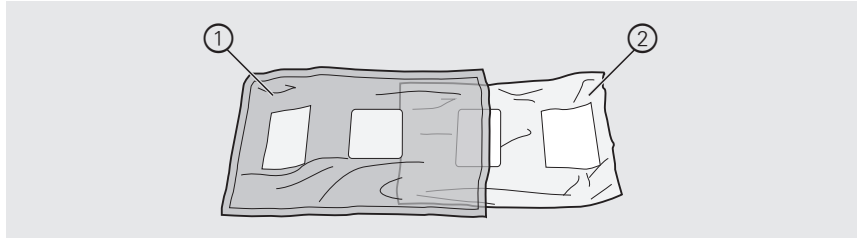
- ▶ Open the second film (2) only in the clean room and while wearing gloves (nitrile)

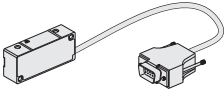
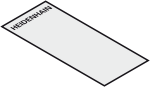
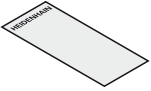
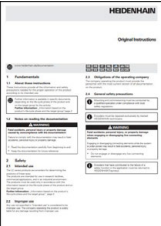

Component	Figure
Scanning head	
Spacer shim 0.15 mm (not needed)	
Spacer shim 0.75 mm	
Operating Instructions	
Manufacturer's Inspection Document	

## 3.2 Mounting accessories

The following accessories can be ordered separately from HEIDENHAIN.



For more information on the listed products, please refer to the applicable Mounting Instructions and the **Exposed Linear Encoders** brochure.



- ▶ [www.heidenhain.com/documentation](http://www.heidenhain.com/documentation)
- ▶ Enter the document ID **208960**

### 3.2.1 Accessories for mounting the linear scale

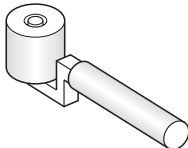
#### Accessories for mounting with adhesive film

Designation	ID	Figure
Roller	276885-01	

#### Accessories for mounting with fixing clamps

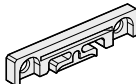
Designation	ID	Figure
Spacer shim	1176441-xx	
Fixing clamps	1176458-xx	
Fixed-point elements	1176475-xx	

### 3.2.2 Accessories for mounting the scanning head

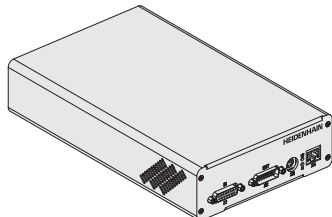
Designation	ID	Figure
PWM 21 inspection device	1200635-51	

#### Adjusting and Testing Software (ATS)

The ATS software is available for download free of charge from [www.heidenhain.com/service/downloads/software/](http://www.heidenhain.com/service/downloads/software/).

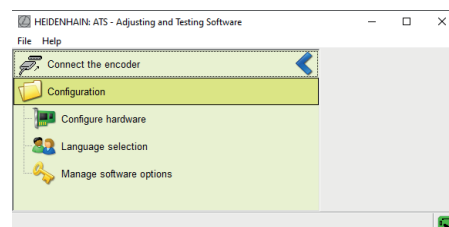

### 3.2.3 Accessories for fixed-point bonding

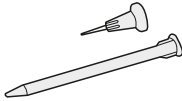
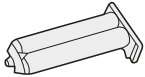
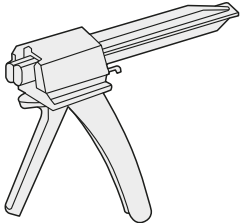
Designation	ID	Figure
Dispensing nozzles and mixing tubes	1176444-01	
Adhesive 3M DP 460 EG	1180444-01	
Double-cartridge gun	1180450-01	

## 4 Mounting

This chapter describes the mounting requirements, different mounting variants, and all other tasks necessary when mounting.

### 4.1 Requirements and notes

#### NOTICE

##### Property damage due to inappropriate tools!

Using inappropriate tools for mounting or removal of the encoder may cause damage to the encoder.

- ▶ Do not use hammers
- ▶ Do not use pointed or sharp-edged tools

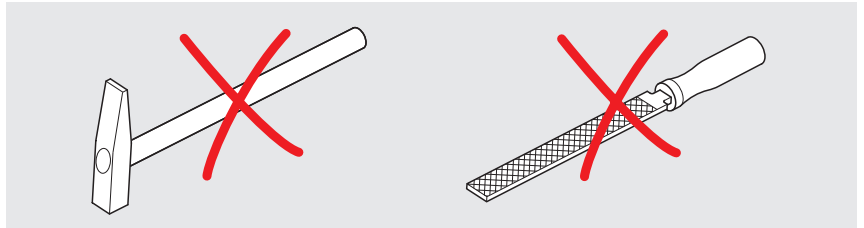

Choose a mounting attitude such that the traverse range is within the measuring length (**ML**) of the encoder. Protect the graduation from direct contamination.

(**S**) = Beginning of measuring length (**ML**)

In order to ensure correct operation of the encoder, the scale or scale tape must be positioned correctly relative to the scanning head.

Code track at top if cable outlet is to the right.

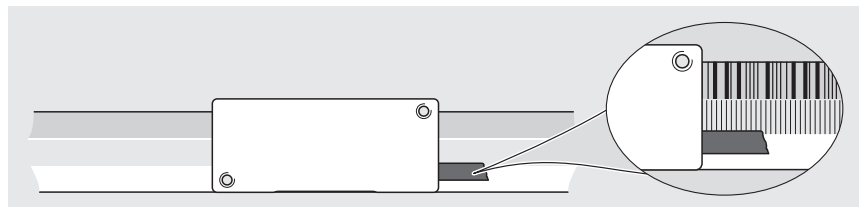
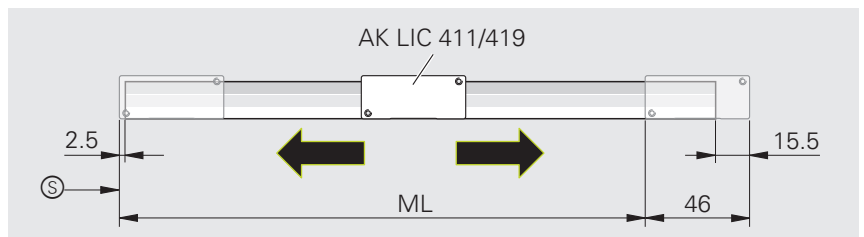

In order to avoid signal interferences, observe the minimum clearance from sources of interference (e.g., power lines).



For more information on sources of interference, refer to the **Interfaces of HEIDENHAIN Encoders** brochure.

- ▶ [www.heidenhain.com/documentation](http://www.heidenhain.com/documentation)
- ▶ Enter the document ID **1078628**

## 4.2 Mounting the linear scale

### 4.2.1 Choosing the mounting variant

#### Mounting variants for the linear scale

Mounting **with adhesive film**

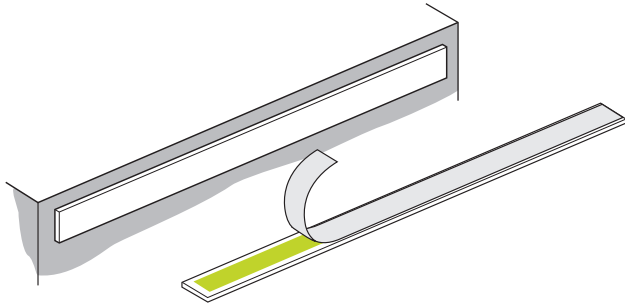

Page 17

Mounting **with fixing clamps**

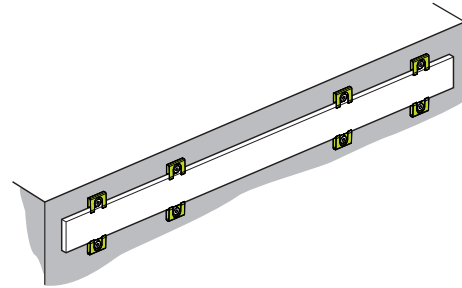

Page 21

### 4.2.2 Variant: Mounting with adhesive film

The mounting variant described in this chapter refers to mounting of the linear scale with an adhesive film.

An overview of the mounting variants is provided on Page 16.

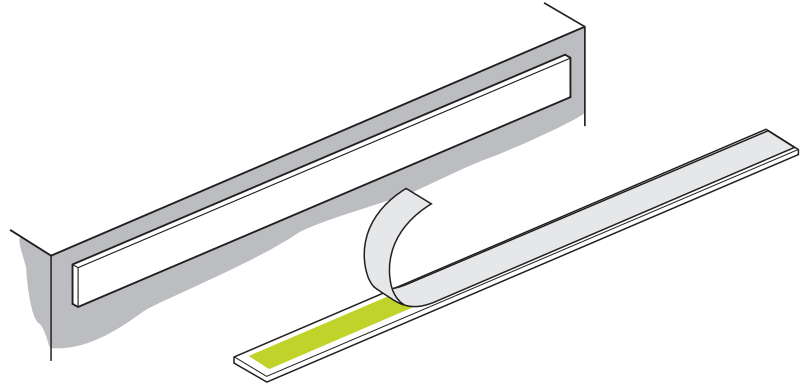

#### Notes on mounting with adhesive film

Note that the mounting surface, as well as the surface of the scale, must be clean and free of paint, dust or grease.

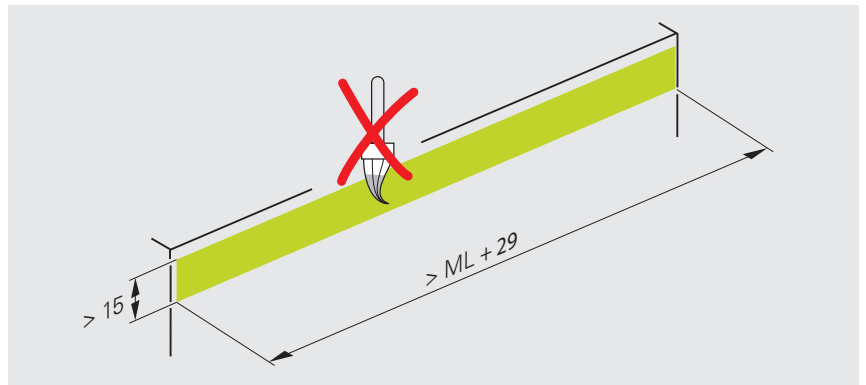

**i** You can mount the linear scale by means of stop pins or an aligning rail.

The mounting tolerances refer to the machine guideway (**F**).

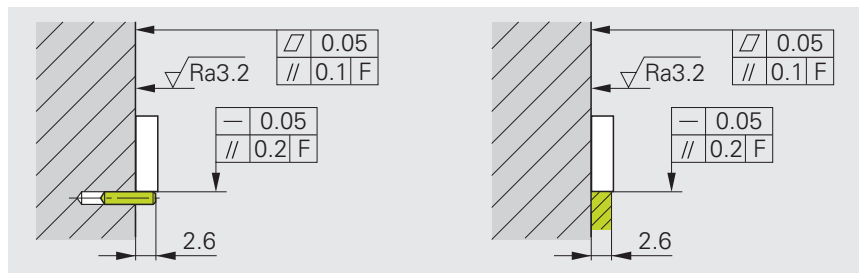

**Number of stop pins to be used**

Recommended diameter of the stop pins: 3 mm.

For a measuring length of **ML ≤ 2040**, use three stop pins to stabilize the scale sufficiently.

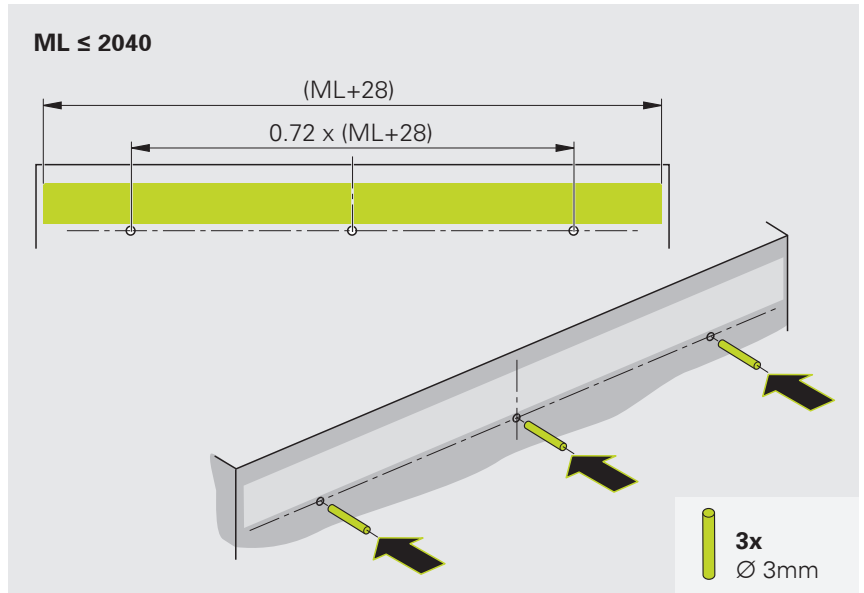

For a measuring length of **ML > 2040**, use five stop pins to stabilize the scale sufficiently.

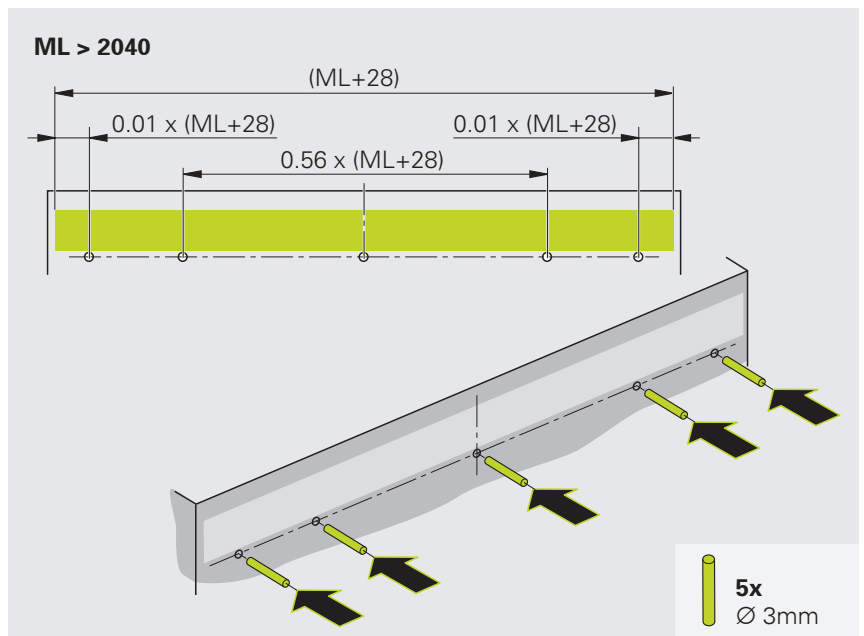

**Materials and tools**

For this task, the following materials and tools are needed:

**Included in delivery**

**To be provided separately**

- Stop pins
- Roller
- Dispensing nozzle and mixing tubes
- Adhesive 3M DP 460 EG
- Double-cartridge gun

**Gluing the linear scale**

Attach the scale with adhesive mounting film only at a temperature of > 15 °C.

Pay attention to the expiration date on the package.

- ▶ Insert the stop pins
- ▶ Remove the protective foil from the adhesive film

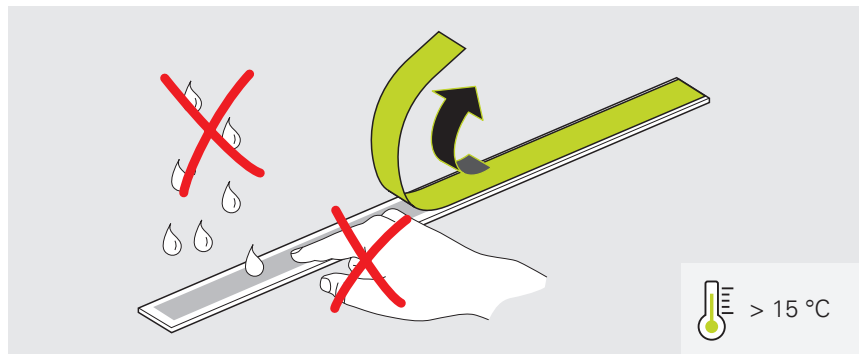

- ▶ Carefully place the scale onto the stop pins
- ▶ Starting from the center, evenly press the scale onto the mounting surface using the roller
- ▶ Remove the stop pins

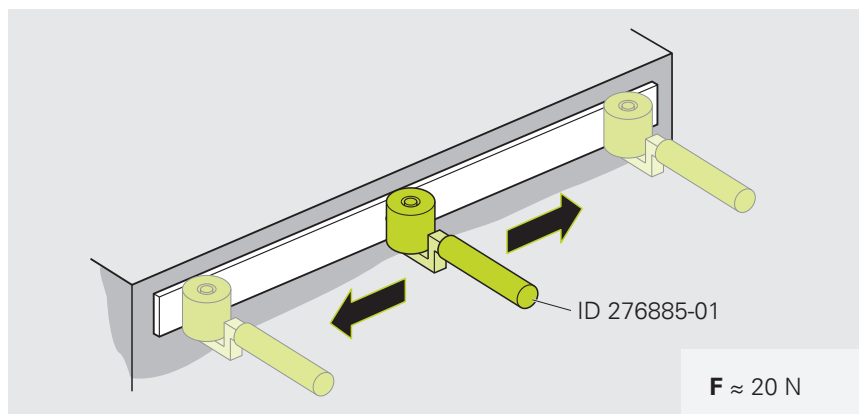

- ▶ Do not perform further work on the linear scale until the maximum adhesive force has been reached

**i** The maximum adhesive force of the mounting film is reached at room temperature after approx. 70 hours.

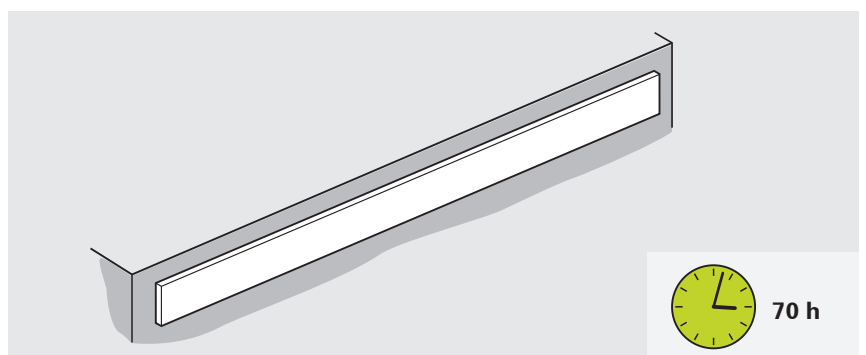

### Bonding the fixed point

Due to potential thermal effects, HEIDENHAIN recommends fixed-point bonding at the center.

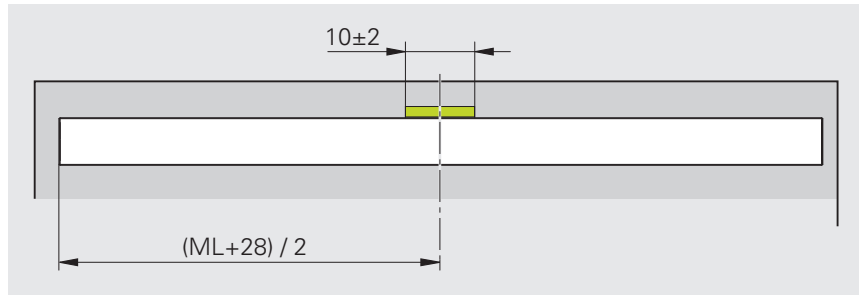

**i** Pay attention to the work instructions in the applicable documentation.

**i** Do not add more adhesive afterwards.

- ▶ Apply a bead of adhesive with a double cartridge gun and a dispensing nozzle.
- ▶ Allow the adhesive to harden as appropriate for the intended operating temperature

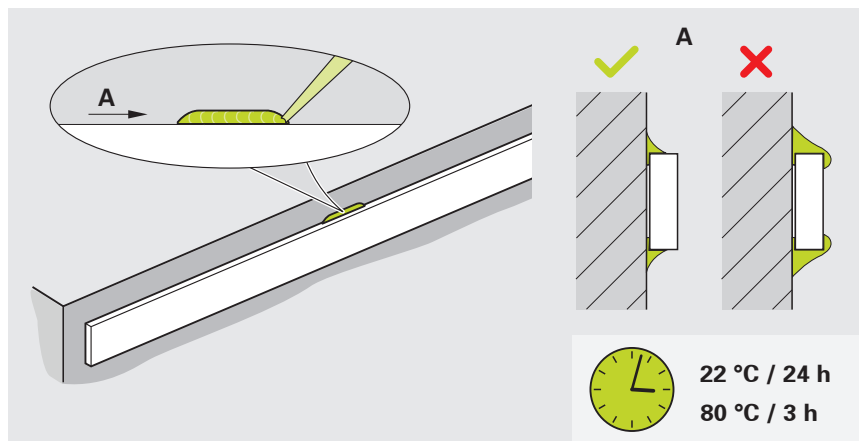

To ensure high fixed-point rigidity, pay attention to the specifications for curing temperature and curing time.

Operating temperature	Curing temperature	Curing time
-10 °C to +30 °C	22 °C	24 hours
-10 °C to +70 °C	80 °C	3 hours

**Next step:** "Mounting the scanning head", Page 27

### 4.2.3 Variant: Mounting with fixing clamps

The mounting variant described in this chapter refers to mounting of the linear scale with fixing clamps.

An overview of the mounting variants is provided on Page 16.

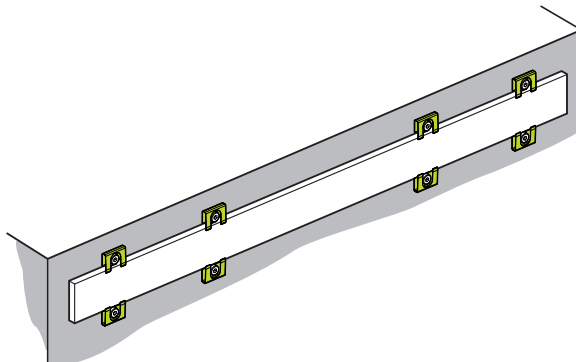

#### Notes on mounting with fixing clamps

Note that the mounting surface, as well as the surface of the scale, must be clean and free of paint, dust or grease.

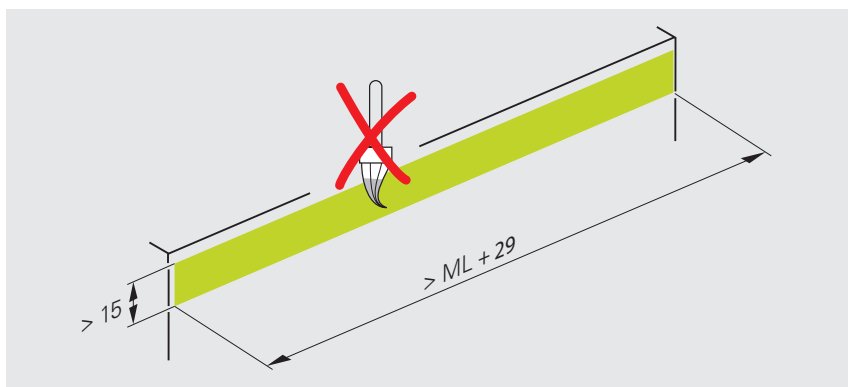

The mounting tolerances refer to the machine guideway (**F**).

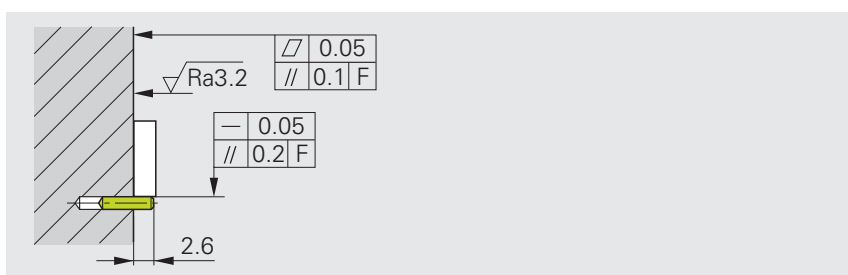

**Number of stop pins to be used**

Recommended diameter of the stop pins: 3 mm.

For a measuring length of **ML ≤ 2040**, use three stop pins to stabilize the scale sufficiently.

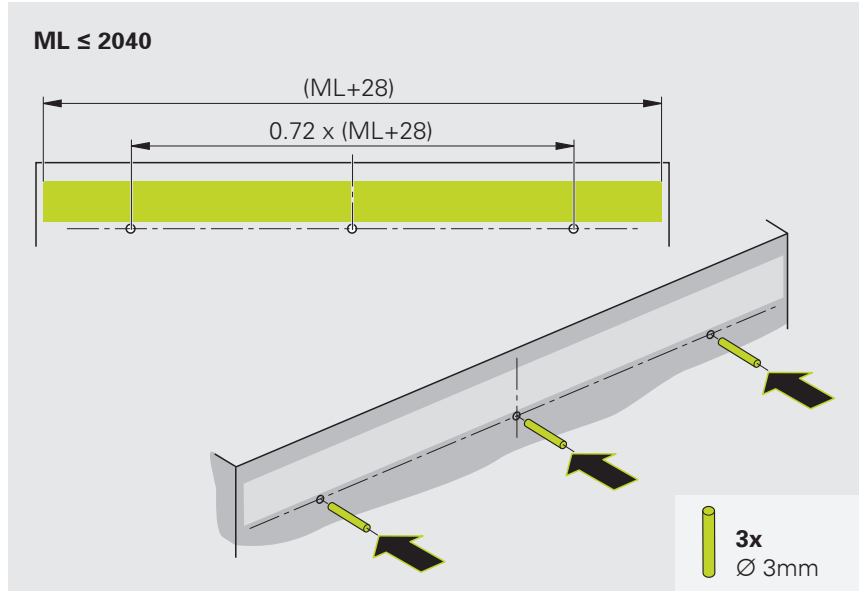

For a measuring length of **ML > 2040**, use five stop pins to stabilize the scale sufficiently.

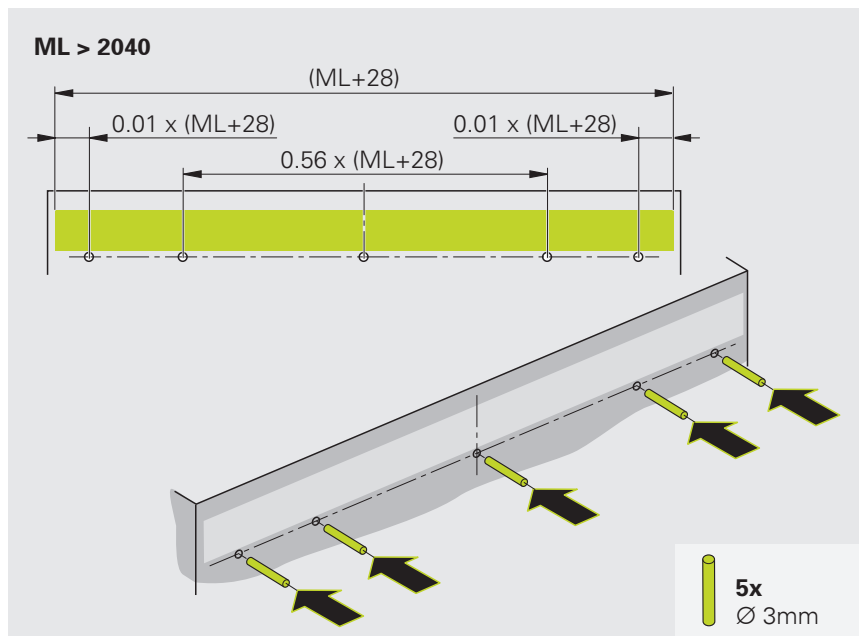

**Materials and tools**

For this task, the following materials and tools are needed:

**Included in delivery**

**To be provided separately**

- Fixing clamps
- Spacer shims
- Stop pins
- Fixed-point elements
- Screws (DIN 7984 – M3x6)
- Washers (ISO 7092–3)
- Torque wrench (hexagon socket for 2.5 mm)
- Dispensing nozzle and mixing tubes
- Adhesive 3M DP 460 EG
- Double-cartridge gun

**Mounting the fixing clamps**

- ▶ Insert the stop pins
- ▶ Remove the protective film of the scale
- ▶ Carefully place the scale onto the stop pins

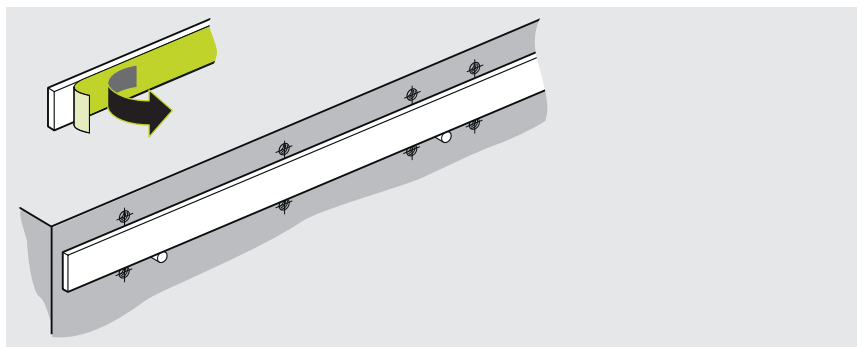

- ▶ Press all fixing clamps lightly in the direction of the scale and fasten them with screws and washers. Tighten the screws only lightly

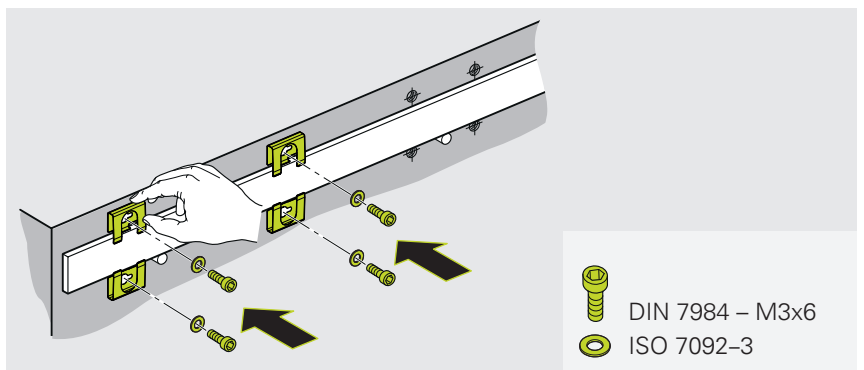

Perform the following steps only with those fixing clamps that are nearest to, but across from, a stop pin:

**i** For a measuring length of  $ML \leq 2040$   
 = 2 fixing clamps  
 For a measuring length of  $ML > 2040$   
 = 4 fixing clamps

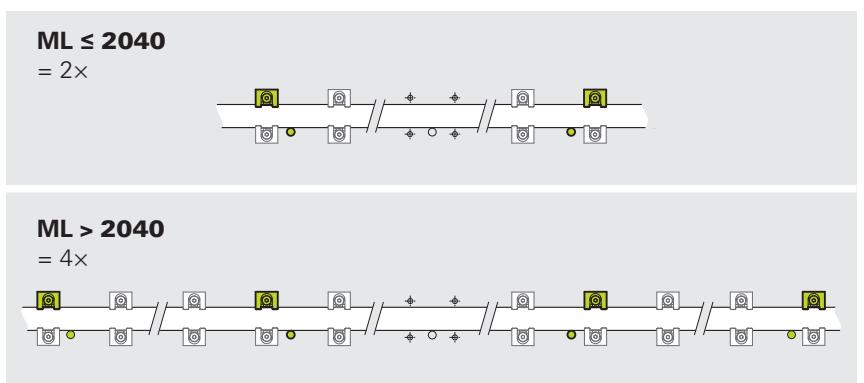

- ▶ Place the spacer shim between the fixing clamp and scale
- ▶ Align the fixing clamp at a right angle to the scale
- ▶ Tighten the screw using the prescribed torque



Do not remove the spacer shims.

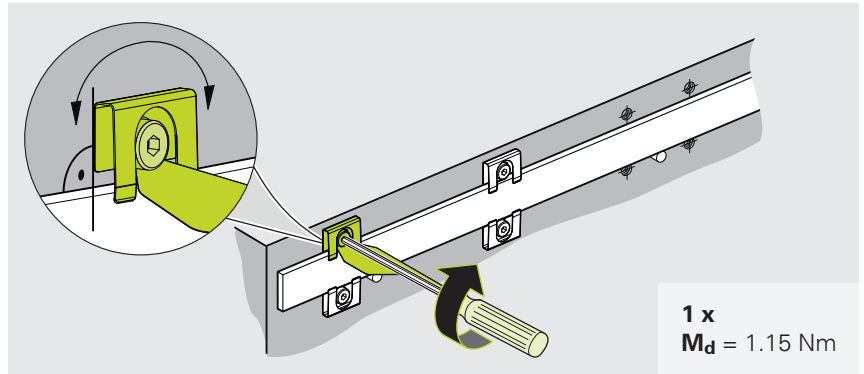

### Mounting the fixed-point element

Pay attention to the mounting dimensions. Deviations from the mounting dimensions lead to imprecise measurement results during operation.

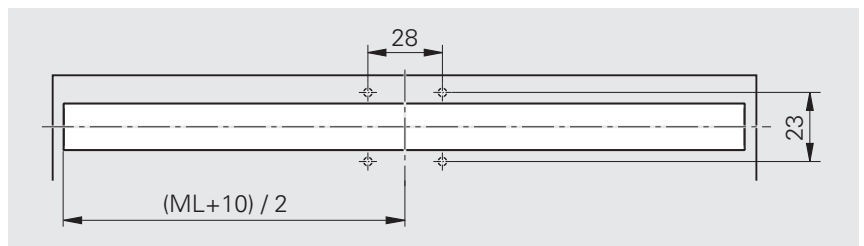

- ▶ Align the fixed-point element in parallel
- ▶ Lightly press the upper fixed-point element against the scale and fasten it with screws using the prescribed torque

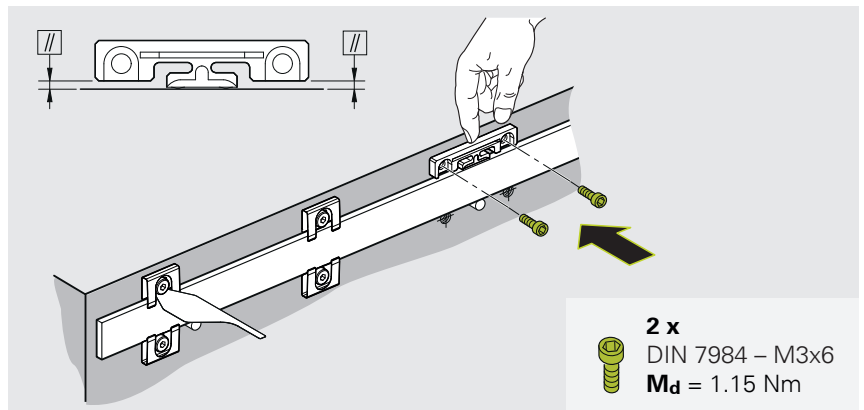

- ▶ Remove the stop pin

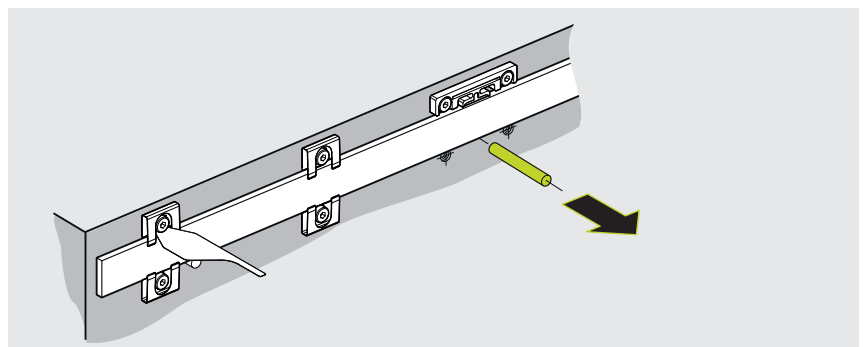

- ▶ Align the fixed-point element in parallel
- ▶ Lightly press the lower fixed-point element against the scale and fasten it with screws using the prescribed torque

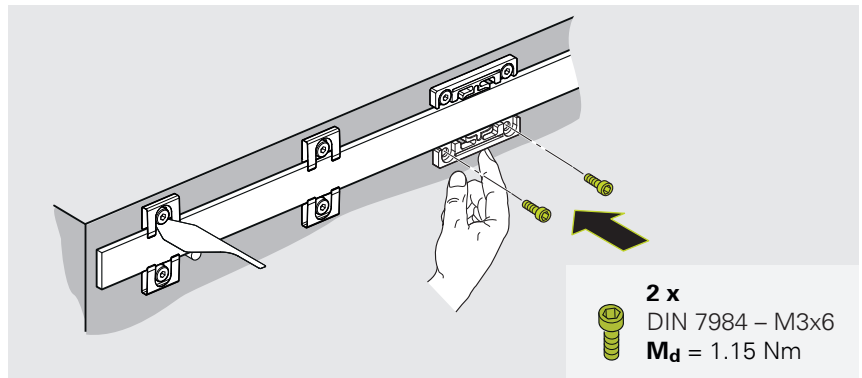

### Tightening the fixing clamps

- i**
- The figure shows an example. The number and position of the fixing clamps and stop pins depends on the length of the linear scale.
  - Always tighten the fixing clamps in pairs.

- ▶ Place the spacer shims between each pair of fixing clamps and the scale
- ▶ Tighten the screws using the prescribed torque
- ▶ Remove the spacer shims and use them for the next pair of fixing clamps
- ▶ Tighten the screws in the sequence shown

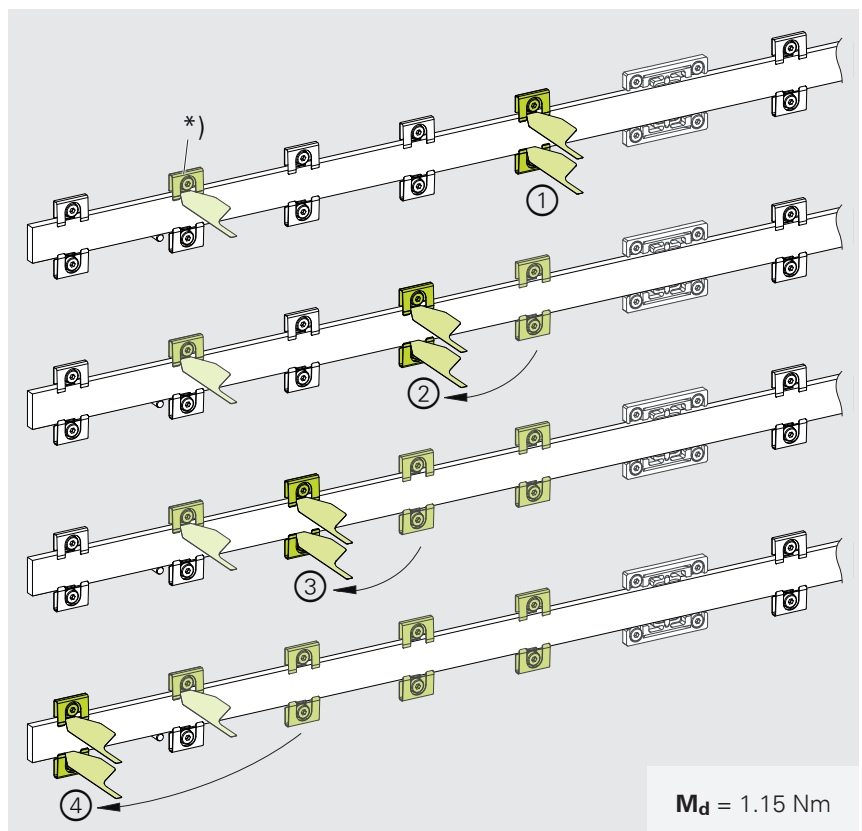

\*) Do not remove the spacer shims from the first tightened fixing clamps until all fixing clamps have been tightened.

- ▶ Remove the stop pin
- ▶ Finally, tighten the fixing clamp opposite the first fixing clamp that was tightened
- ▶ Tighten the screws on the other side of the fixed-point element according to the same pattern

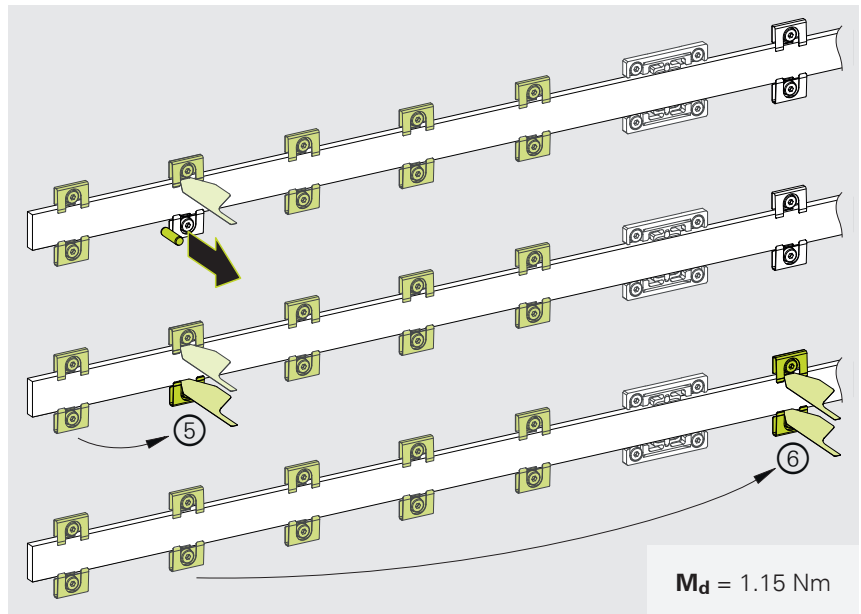

#### Gluing the fixed-point element

**i** Pay attention to the work instructions in the applicable documentation.

**i** Do not add more adhesive afterwards.

- ▶ Apply a bead of adhesive with a double cartridge gun and a dispensing nozzle.
- ▶ Allow the adhesive to harden as appropriate for the intended operating temperature

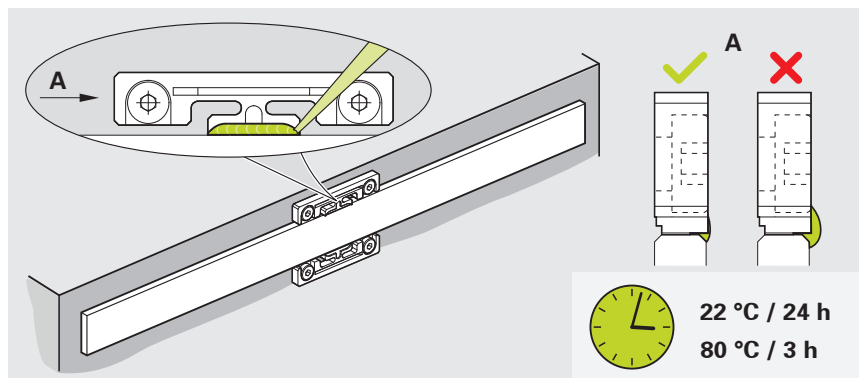

To ensure high fixed-point rigidity, pay attention to the specifications for curing temperature and curing time.

Operating temperature	Curing temperature	Curing time
-10 °C to +30 °C	22 °C	24 hours
-10 °C to +70 °C	80 °C	3 hours

**Next step:** "Mounting the scanning head", Page 27

## 4.3 Mounting the scanning head

### 4.3.1 Selecting the product variant

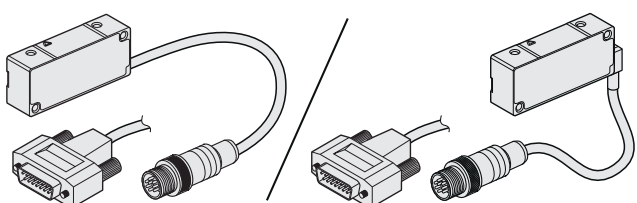
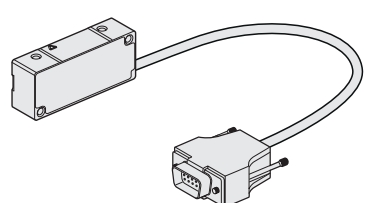
Scanning head variants	
LIC 411, LIC 413, LIC 419	LIC 411V, 419FV, MV, PV
	
<b>Page 28</b>	<b>Page 41</b>

### 4.3.2 Mounting the LIC 411, LIC 413, LIC 419 scanning heads

The mounting procedure described in this chapter refers to mounting of the LIC 411, LIC 413 and LIC 419 scanning heads.

An overview of the mounting variants is provided on Page 27.

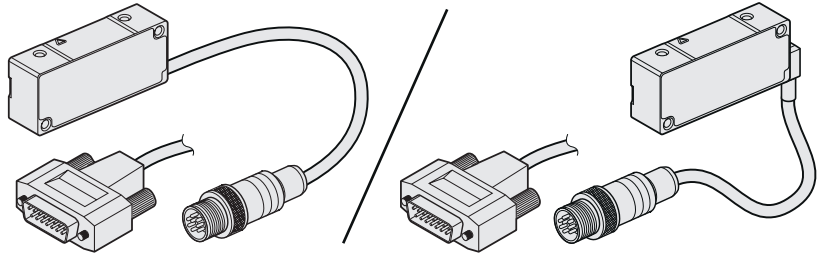

#### Choosing the mounting variant

##### Mounting variants for the scanning head

Holder **on the side**

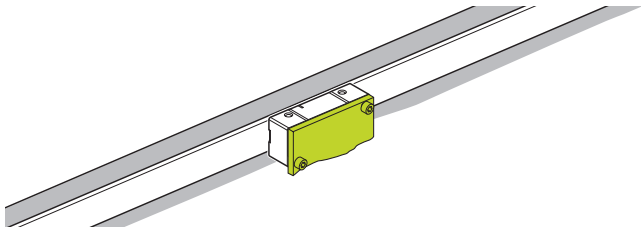

Page 29

Holder **at the top**

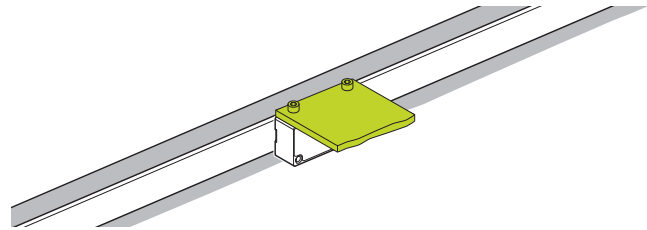

Page 33

Holder **at the bottom**

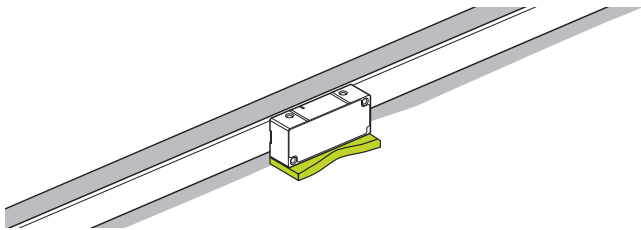

Page 37

**Variant: Mounting with the holder on the side**

The mounting variant described in this chapter refers to mounting of the scanning head with the holder on the side.

An overview of the mounting variants is provided on Page 28.

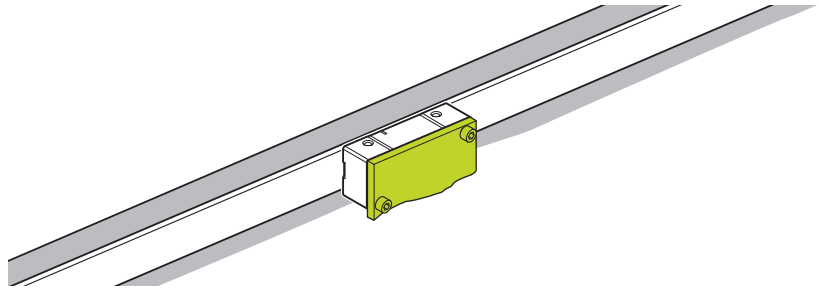

**Notes on mounting the scanning head with the holder on the side**

**i** The tightening torques of the mounting screws are only valid for mounting on steel.

**i** If necessary, clean the graduation and the scanning head with a lint-free cloth and isopropyl alcohol.

**NOTICE**

**Property damage due to unsuitable cleaning agents!**

- ▶ Use only isopropyl alcohol to clean the encoder
- ▶ Clean the encoder with a lint-free cloth

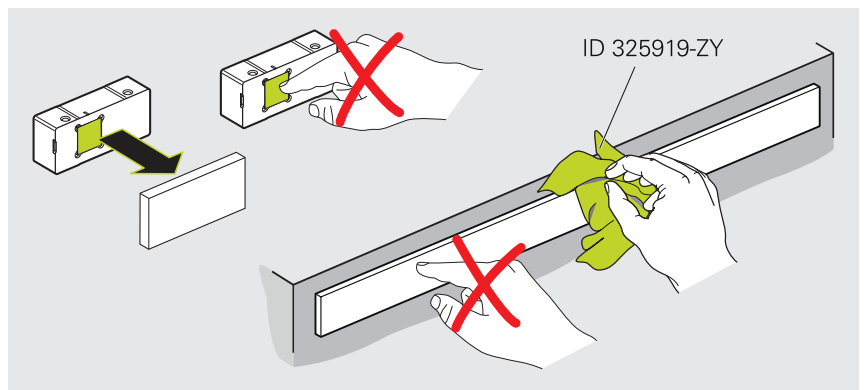

Pay attention to the mounting dimensions. Deviations from the mounting dimensions lead to imprecise measurement results during operation.

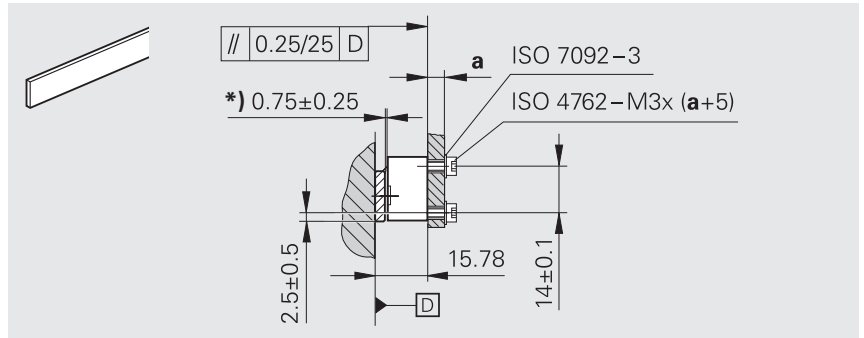

\*) Mounting clearance between the scanning head and graduation.

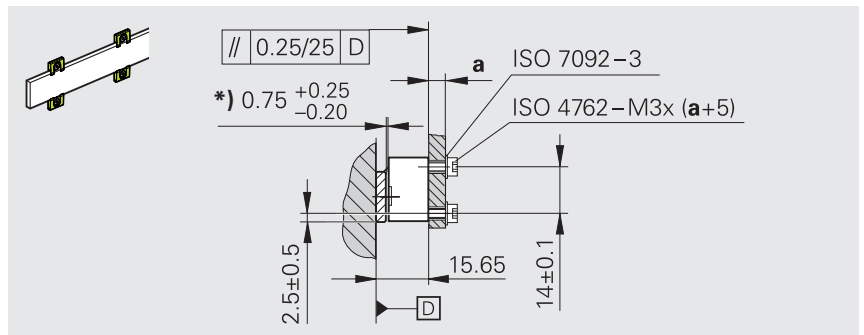

\*) Mounting clearance between the scanning head and graduation.

#### Special case for ID 1196309-xx

Limited mounting tolerance resulting from deactivated code-connection expansion

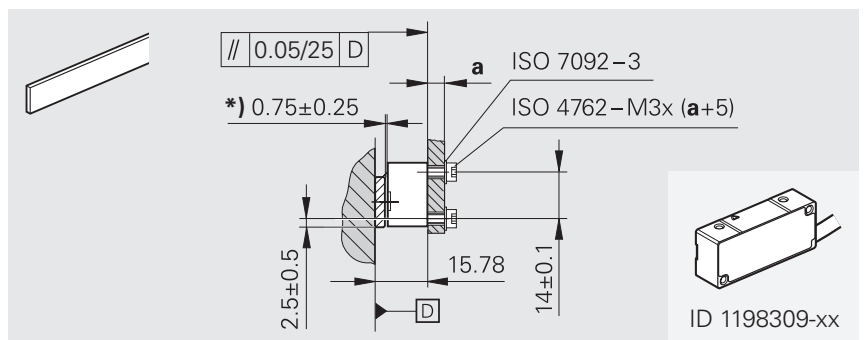

\*) Mounting clearance between the scanning head and graduation.

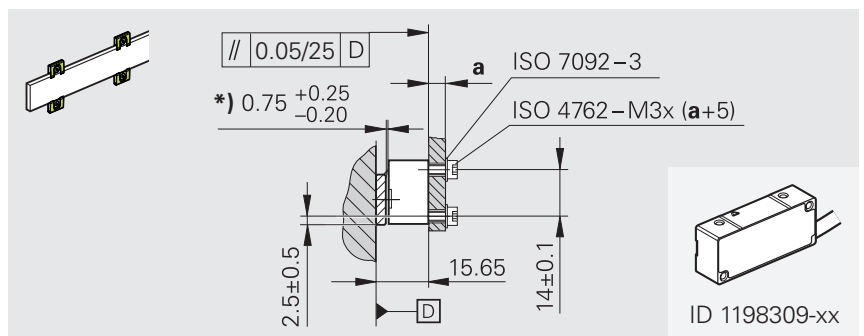

\*) Mounting clearance between the scanning head and graduation.

**Additional notes on mounting the scanning head with angled cable outlet**

**NOTICE**

**Property damage due to mechanical stress!**

Exceeding the pivot range may damage the scanning head.

- Do not pull the cable
- Observe the maximum permissible pivot range of the adjustable cable outlet (0° to 180°)
- Rotate the cable only a few times (less than 10)

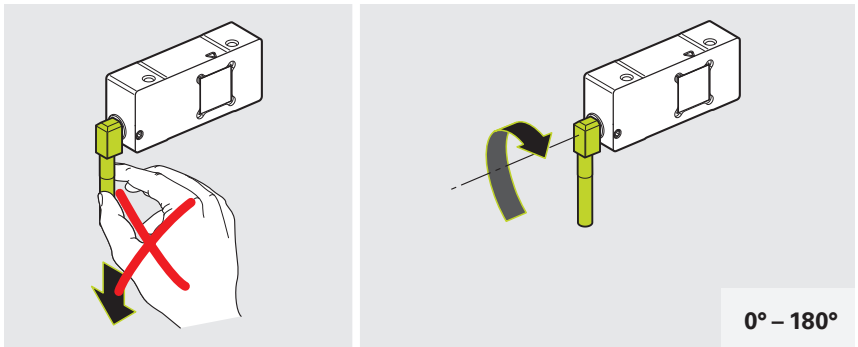

**Adjusting the angular position of the cable**

- ▶ Loosen the setscrew

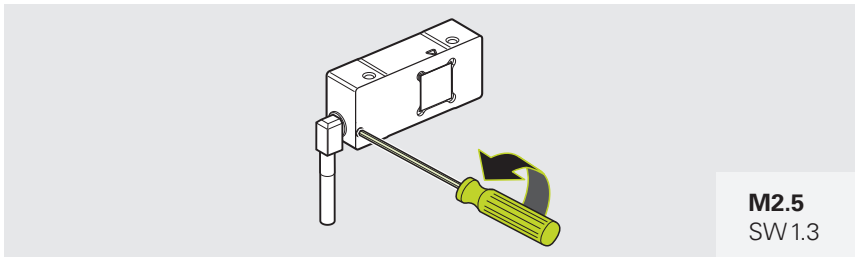

- ▶ Rotate the cable to the desired angular position

**i** If necessary, use a flat wrench to rotate the sleeve

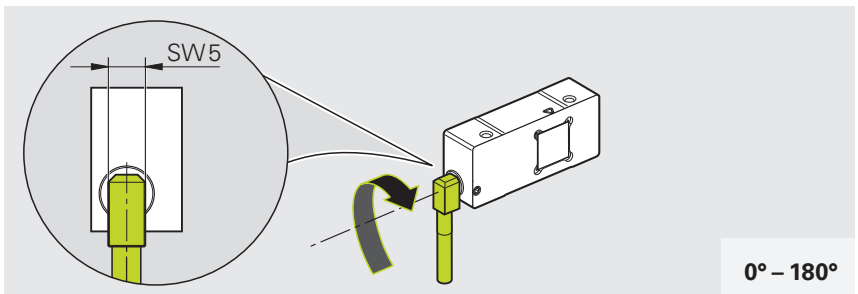

- ▶ Tighten the setscrew with the specified torque

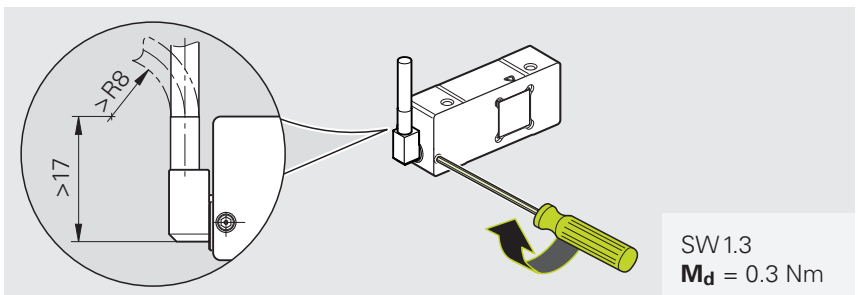

**Materials and tools**

For this task, the following materials and tools are needed:

Included in delivery	To be provided separately
<ul style="list-style-type: none"> <li>■ Spacer shim</li> </ul>	<ul style="list-style-type: none"> <li>■ Two screws (ISO 4762–M3×(a+5))</li> <li>■ Two washers (ISO 7092–3)</li> <li>■ Torque wrench (hexagon socket for 2.5 mm)</li> </ul>

### Mounting the scanning head

- ▶ If necessary, remove the protective cap from the scanning head
- ▶ If necessary, remove the protective film from the scale

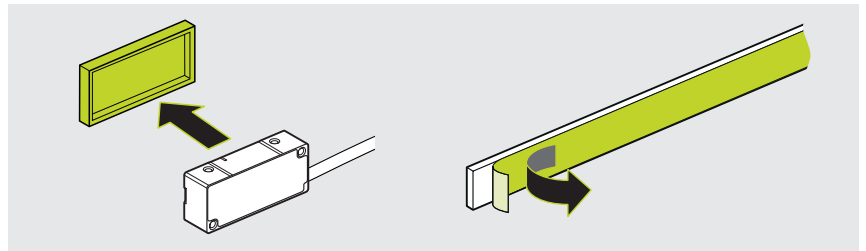

- ▶ Prepare the spacer shim

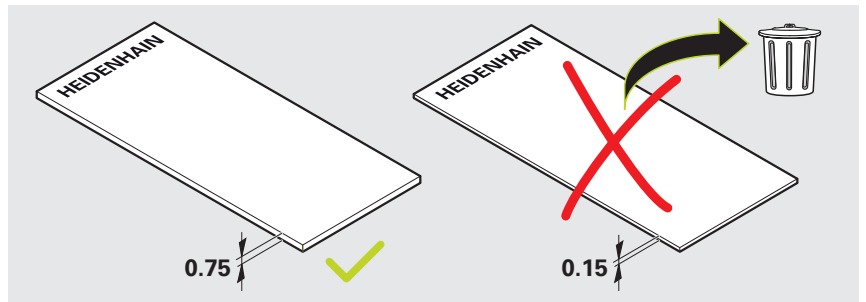

**i** When mounting the linear scale with fixing clamps:  
Do not insert the spacer shim near the fixing clamps.

- ▶ Use the spacer shim to set the mounting clearance
- ▶ Lightly tighten the screws on the scanning head
- ▶ Remove the spacer shim

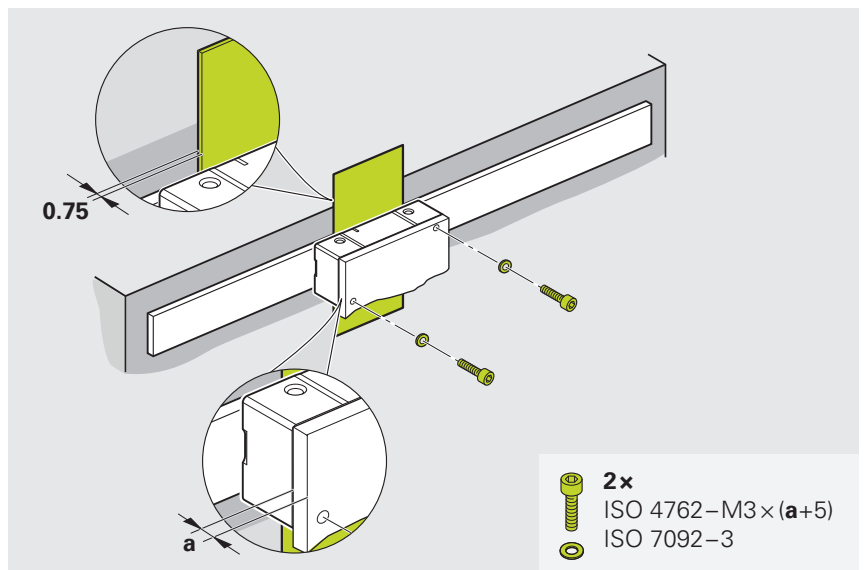

**Next step:** "Adjustment and diagnosis", Page 51

**Variant: Mounting with the holder at top**

The mounting variant described in this chapter refers to mounting of the scanning head with the holder at top.

An overview of the mounting variants is provided on Page 28.

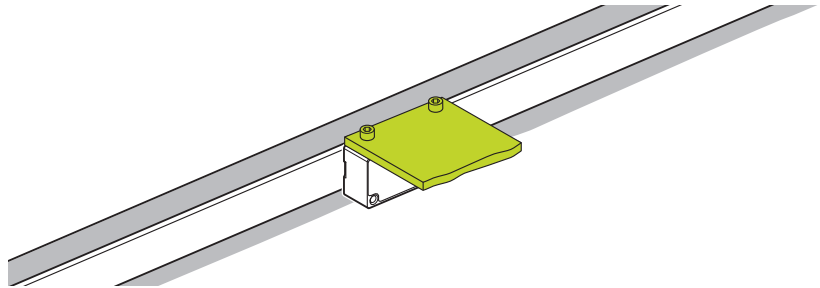

**Notes on mounting the scanning head with the holder at top**

**i** The tightening torques of the mounting screws are only valid for mounting on steel.

**i** If necessary, clean the graduation and the scanning head with a lint-free cloth and isopropyl alcohol.

**NOTICE**

**Property damage due to unsuitable cleaning agents!**

- ▶ Use only isopropyl alcohol to clean the encoder
- ▶ Clean the encoder with a lint-free cloth

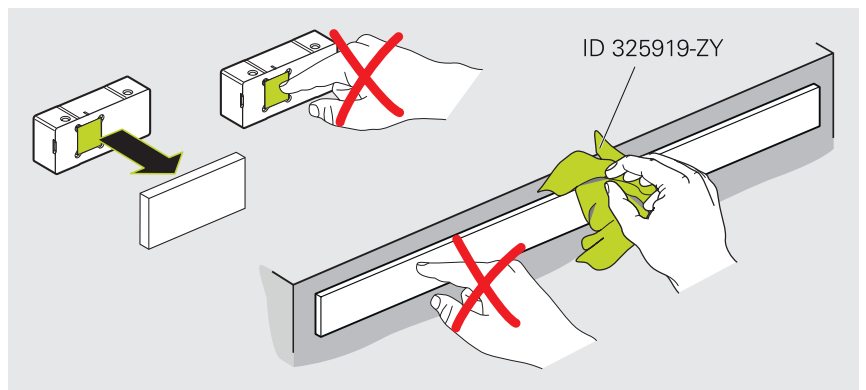

Pay attention to the mounting dimensions. Deviations from the mounting dimensions lead to imprecise measurement results during operation.

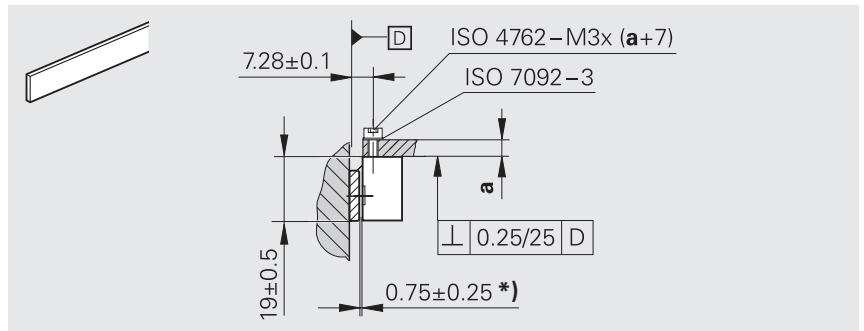

\*) Mounting clearance between the scanning head and graduation.

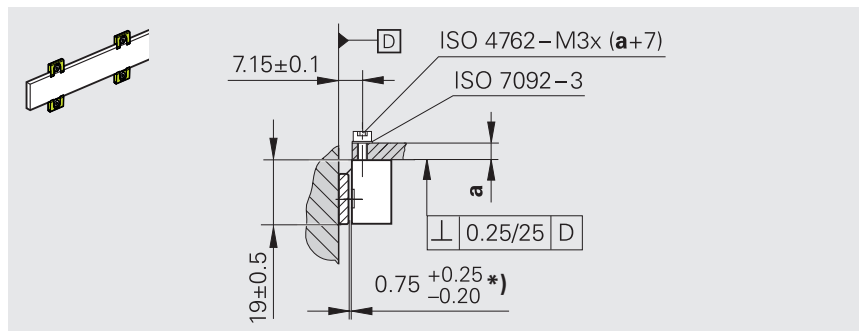

\*) Mounting clearance between the scanning head and graduation.

#### Special case for ID 1196309-xx

Limited mounting tolerance resulting from deactivated code-connection expansion

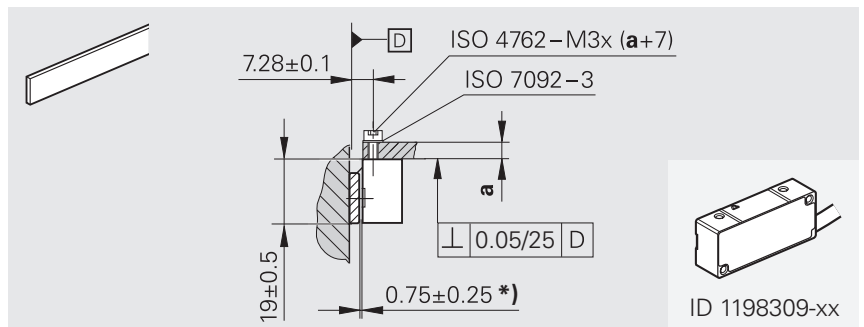

\*) Mounting clearance between the scanning head and graduation.

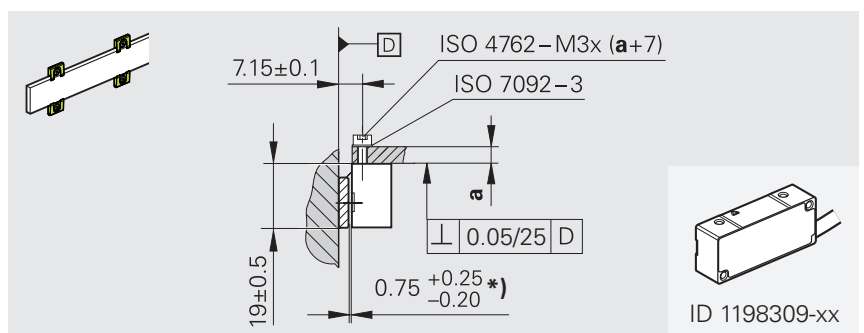

\*) Mounting clearance between the scanning head and graduation.

**Additional notes on mounting the scanning head with angled cable outlet**

**NOTICE**

**Property damage due to mechanical stress!**

Exceeding the pivot range may damage the scanning head.

- Do not pull the cable
- Observe the maximum permissible pivot range of the adjustable cable outlet (0° to 180°)
- Rotate the cable only a few times (less than 10)

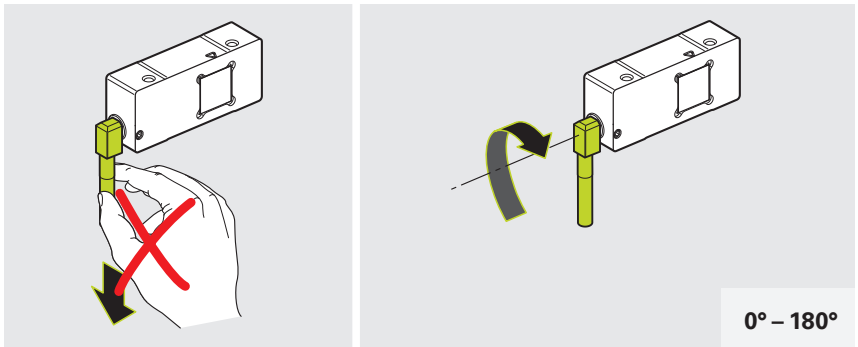

**Adjusting the angular position of the cable**

- ▶ Loosen the setscrew

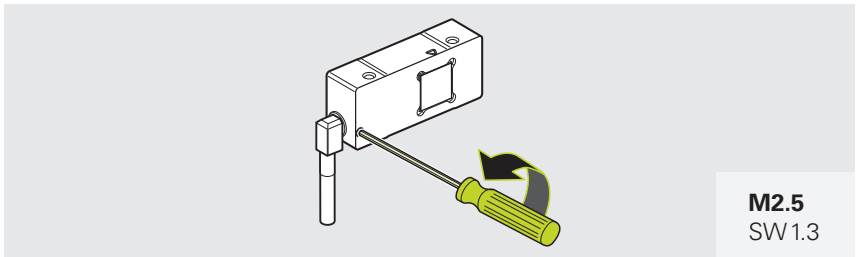

- ▶ Rotate the cable to the desired angular position

**i** If necessary, use a flat wrench to rotate the sleeve

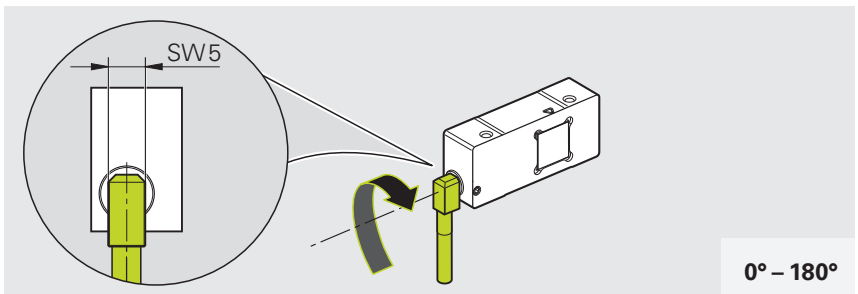

- ▶ Tighten the setscrew with the specified torque

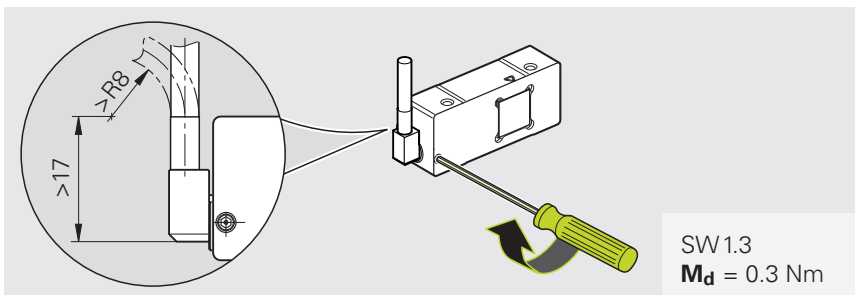

**Materials and tools**

For this task, the following materials and tools are needed:

Included in delivery	To be provided separately
<ul style="list-style-type: none"> <li>■ Spacer shim</li> </ul>	<ul style="list-style-type: none"> <li>■ Two screws (ISO 4762–M3×(a+7))</li> <li>■ Two washers (ISO 7092–3)</li> <li>■ Torque wrench (hexagon socket for 2.5 mm)</li> </ul>

### Mounting the scanning head

- ▶ If necessary, remove the protective cap from the scanning head
- ▶ If necessary, remove the protective film from the scale

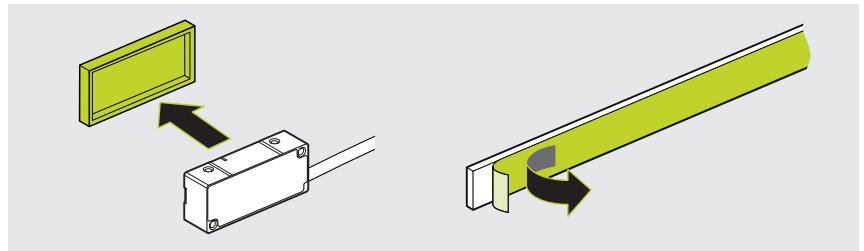

- ▶ Prepare the spacer shim

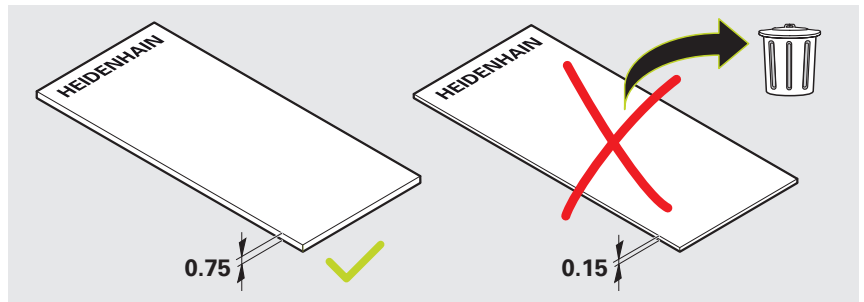

**i** When mounting the linear scale with fixing clamps:  
Do not insert the spacer shim near the fixing clamps.

- ▶ Use the spacer shim to set the mounting clearance
- ▶ Lightly tighten the screws on the scanning head
- ▶ Remove the spacer shim

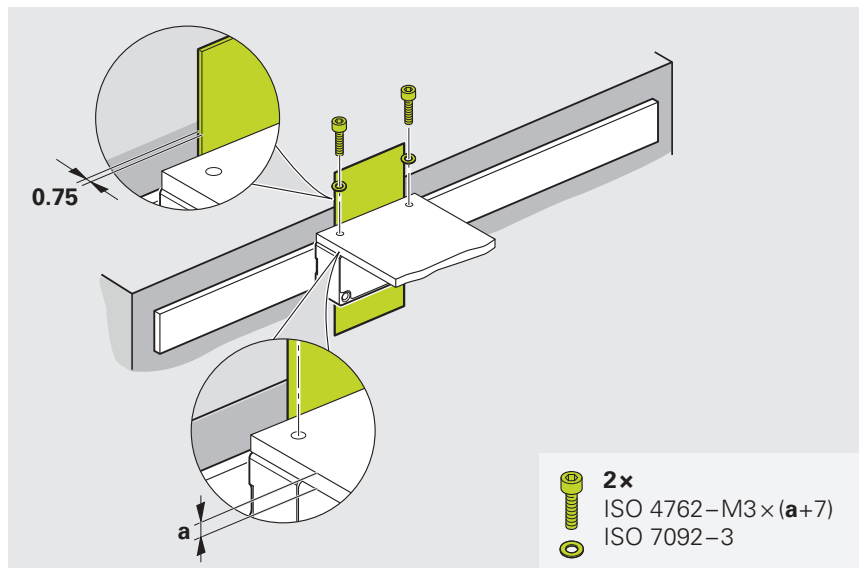

**Next step:** "Adjustment and diagnosis", Page 51

**Variant: Mounting with the holder at bottom**

The mounting variant described in this chapter refers to mounting of the scanning head with the holder at bottom.

An overview of the mounting variants is provided on Page 28.

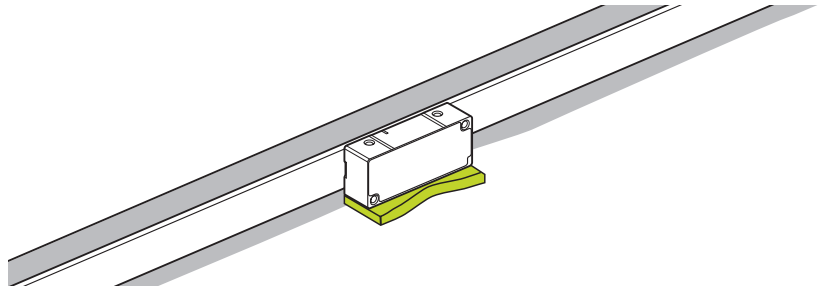

**Notes on mounting the scanning head with the holder at bottom**

**i** The tightening torques of the mounting screws are only valid for mounting on steel.

**i** If necessary, clean the graduation and the scanning head with a lint-free cloth and isopropyl alcohol.

**NOTICE**

**Property damage due to unsuitable cleaning agents!**

- ▶ Use only isopropyl alcohol to clean the encoder
- ▶ Clean the encoder with a lint-free cloth

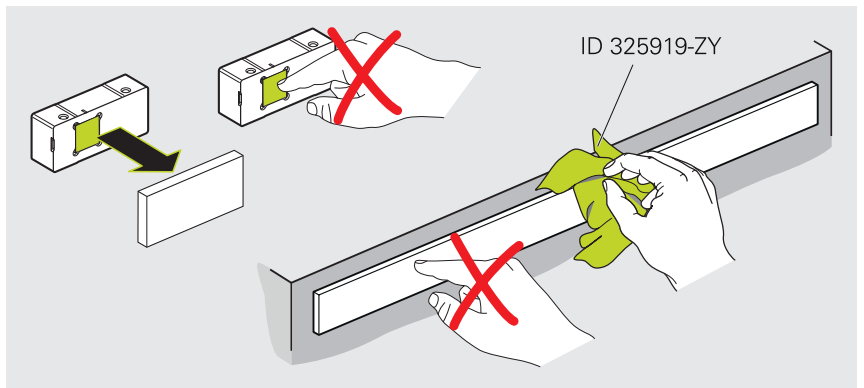

Pay attention to the mounting dimensions. Deviations from the mounting dimensions lead to imprecise measurement results during operation.

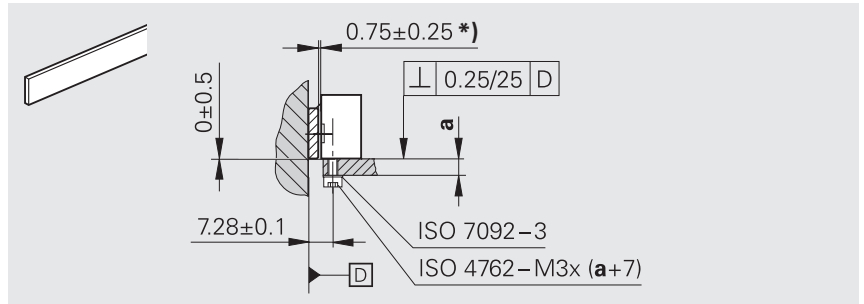

\*) Mounting clearance between the scanning head and graduation.

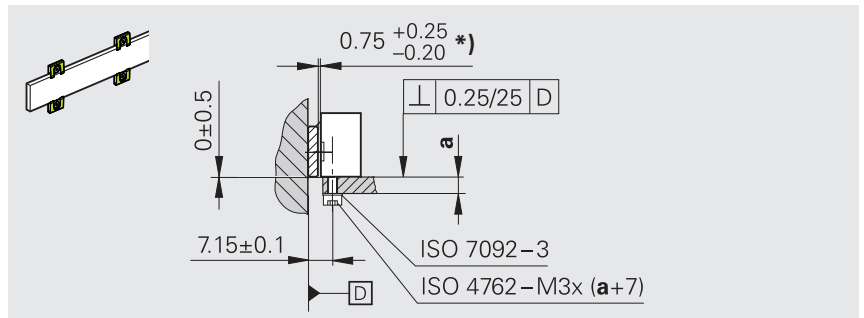

\*) Mounting clearance between the scanning head and graduation.

#### Special case for ID 1196309-xx

Limited mounting tolerance resulting from deactivated code-connection expansion

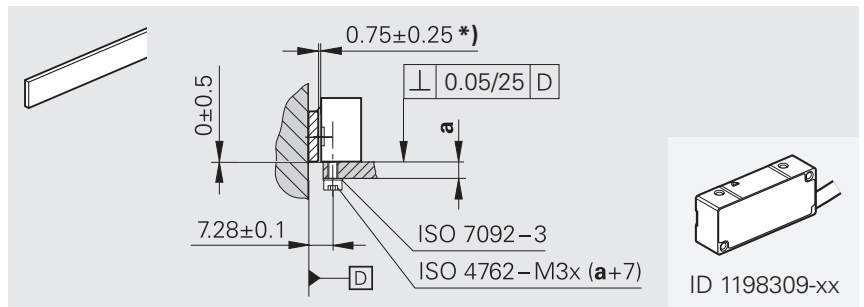

\*) Mounting clearance between the scanning head and graduation.

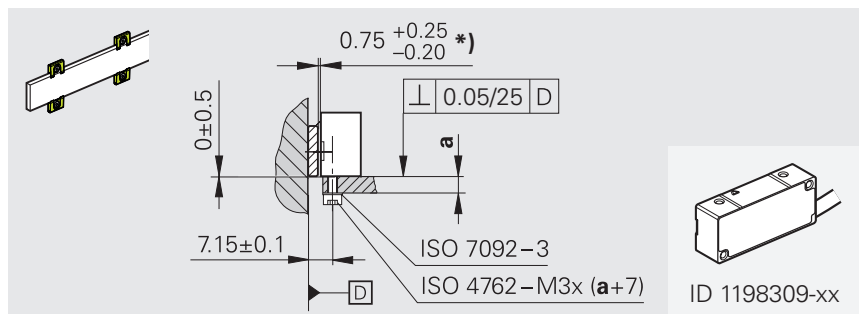

\*) Mounting clearance between the scanning head and graduation.

**Additional notes on mounting the scanning head with angled cable outlet**

**NOTICE**

**Property damage due to mechanical stress!**

Exceeding the pivot range may damage the scanning head.

- Do not pull the cable
- Observe the maximum permissible pivot range of the adjustable cable outlet (0° to 180°)
- Rotate the cable only a few times (less than 10)

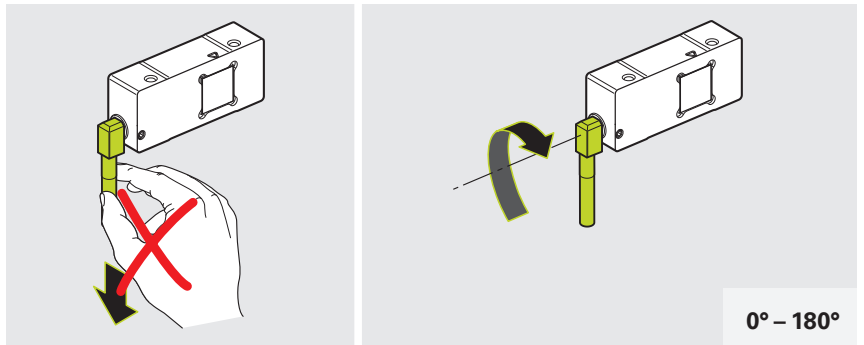

**Adjusting the angular position of the cable**

- ▶ Loosen the setscrew

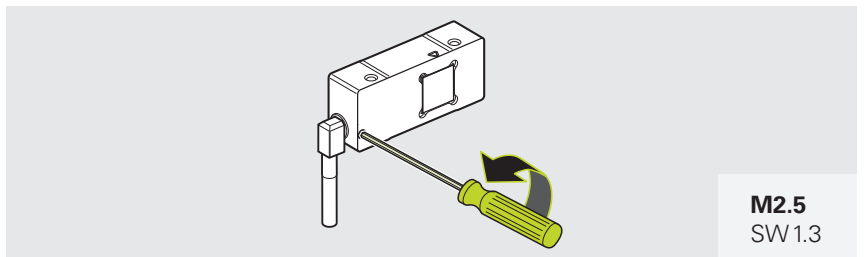

- ▶ Rotate the cable to the desired angular position

**i** If necessary, use a flat wrench to rotate the sleeve

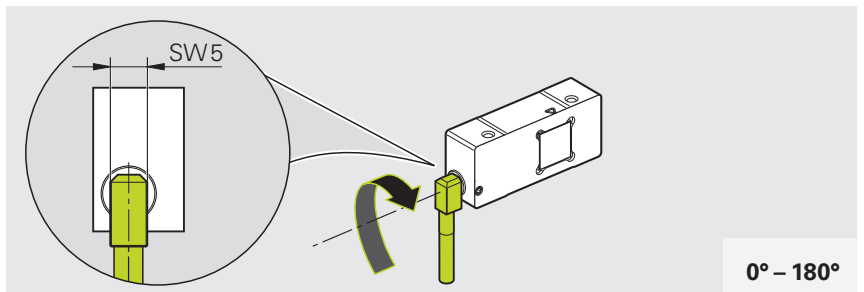

- ▶ Tighten the setscrew with the specified torque

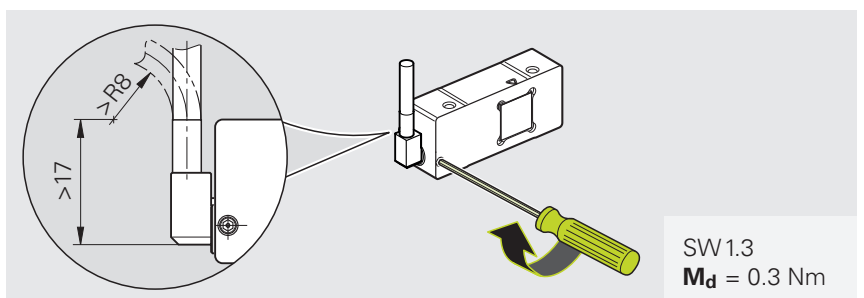

**Materials and tools**

For this task, the following materials and tools are needed:

Included in delivery	To be provided separately
<ul style="list-style-type: none"> <li>■ Spacer shim</li> </ul>	<ul style="list-style-type: none"> <li>■ Two screws (ISO 4762–M3×(a+7))</li> <li>■ Two washers (ISO 7092–3)</li> <li>■ Torque wrench (hexagon socket for 2.5 mm)</li> </ul>

### Mounting the scanning head

- ▶ If necessary, remove the protective cap from the scanning head
- ▶ If necessary, remove the protective film from the scale

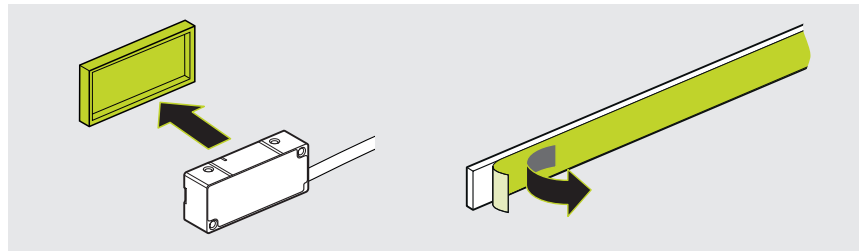

- ▶ Prepare the spacer shim

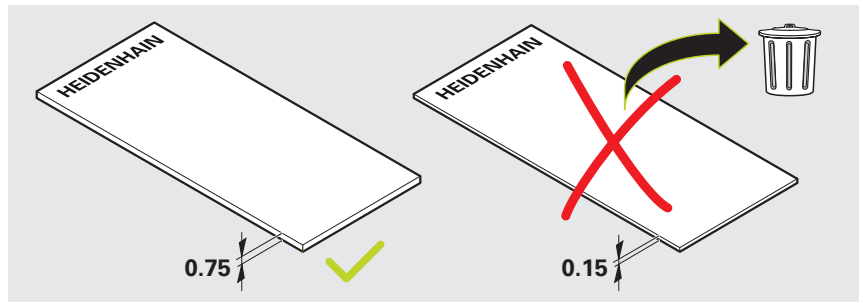

**i** When mounting the linear scale with fixing clamps:  
Do not insert the spacer shim near the fixing clamps.

- ▶ Use the spacer shim to set the mounting clearance
- ▶ Lightly tighten the screws on the scanning head
- ▶ Remove the spacer shim

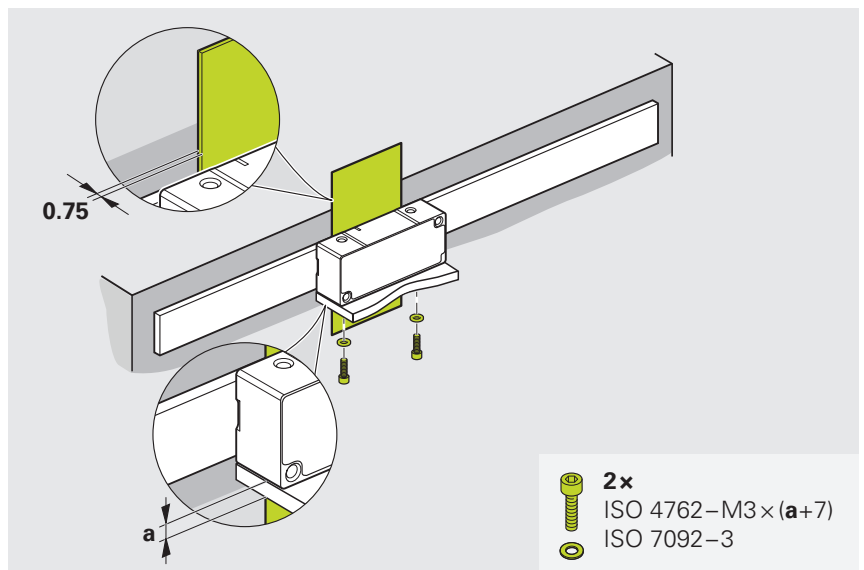

**Next step:** "Adjustment and diagnosis", Page 51

### 4.3.3 Mounting the LIC 411 V, 419 FV, MV, PV scanning heads

The mounting procedure described in this chapter refers to mounting of the LIC 411 V, 419 FV, MV, PV scanning heads.

An overview of the mounting variants is provided on Page 27.

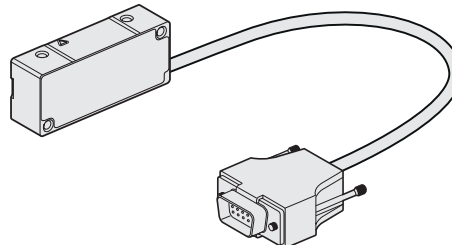

#### Choosing the mounting variant

##### Mounting variants for the scanning head

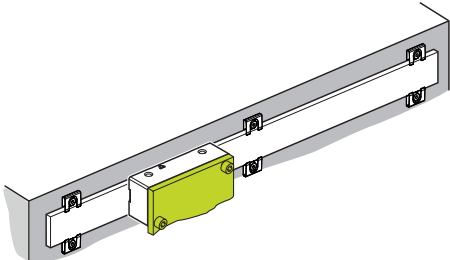
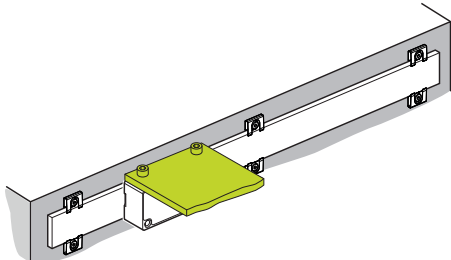
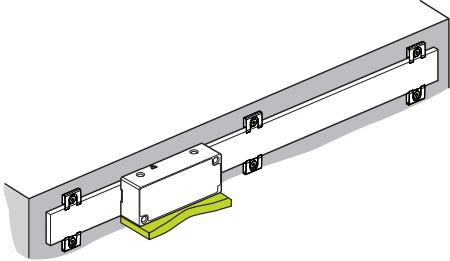
Holder <b>on the side</b>	Holder <b>at the top</b>
 <p data-bbox="113 1155 212 1193"><b>Page 42</b></p>	 <p data-bbox="799 1155 898 1193"><b>Page 45</b></p>
Holder at the <b>bottom</b>	
 <p data-bbox="113 1547 212 1585"><b>Page 48</b></p>	

### Variant: Mounting with the holder on the side

The mounting variant described in this chapter refers to mounting of the scanning head with the holder on the side.

An overview of the mounting variants is provided on Page 41.

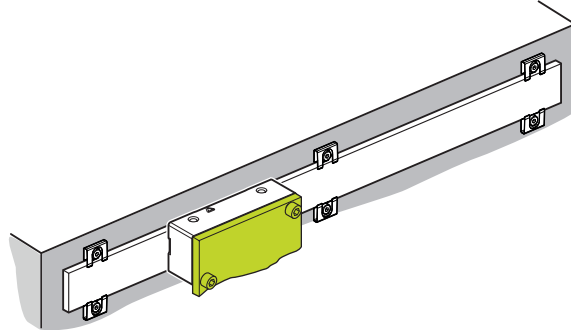

### Notes on mounting the scanning head with the holder on the side

- i** The tightening torques of the mounting screws are only valid for mounting on steel.

#### NOTICE

#### Property damage due to the evacuation process!

- ▶ Disconnect the encoder from the power supply before pumping air into or out of the vacuum chamber

- i** If necessary, clean the graduation and the scanning head with a lint-free cloth and isopropyl alcohol.

#### NOTICE

#### Property damage due to unsuitable cleaning agents!

- ▶ Use only isopropyl alcohol to clean the encoder
- ▶ Clean the encoder with a lint-free cloth

#### NOTICE

#### Property damage due to mechanical stress!

- ▶ Do not stretch or twist the vacuum cable

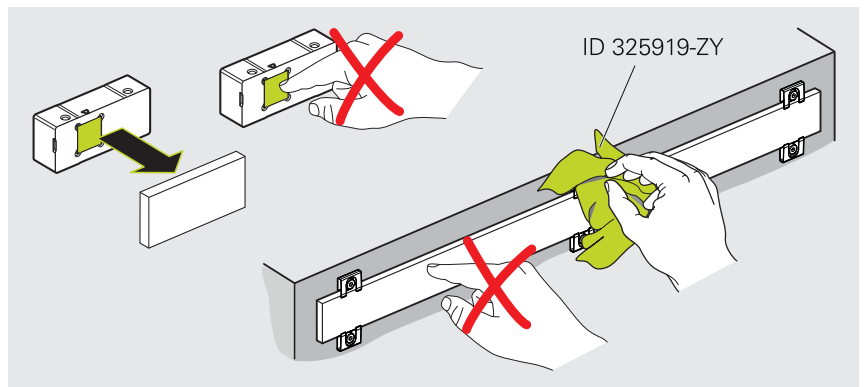

Pay attention to the mounting dimensions. Deviations from the mounting dimensions lead to imprecise measurement results during operation.

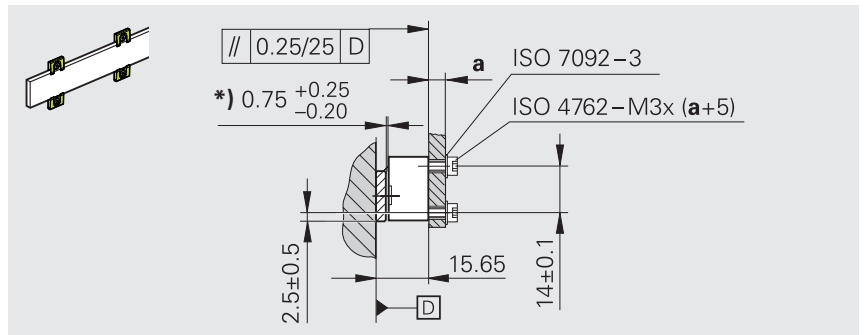

\*) Mounting clearance between the scanning head and graduation.

### Materials and tools

For this task, the following materials and tools are needed:

#### Included in delivery

- Spacer shim

#### To be provided separately

- Two screws (ISO 4762-M3x(a+5))
- Two washers (ISO 7092-3)
- Torque wrench (hexagon socket for 2.5 mm)

### Mounting the scanning head

- ▶ If necessary, remove the protective cap from the scanning head

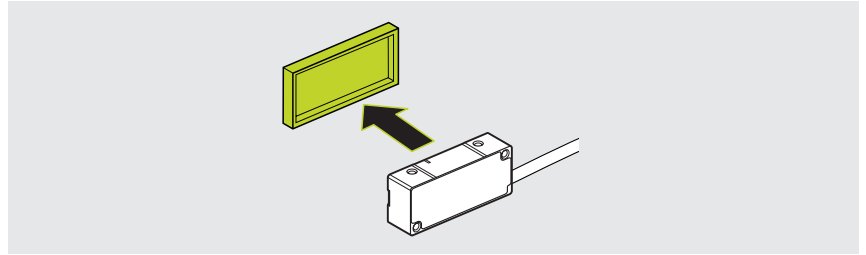

- ▶ Prepare the spacer shim

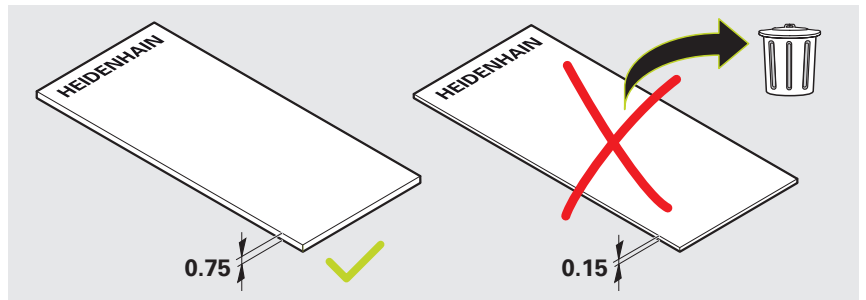

**i** Do not insert the spacer shim near the fixing clamps.

- ▶ Use the spacer shim to set the mounting clearance
- ▶ Lightly tighten the screws on the scanning head
- ▶ Remove the spacer shim

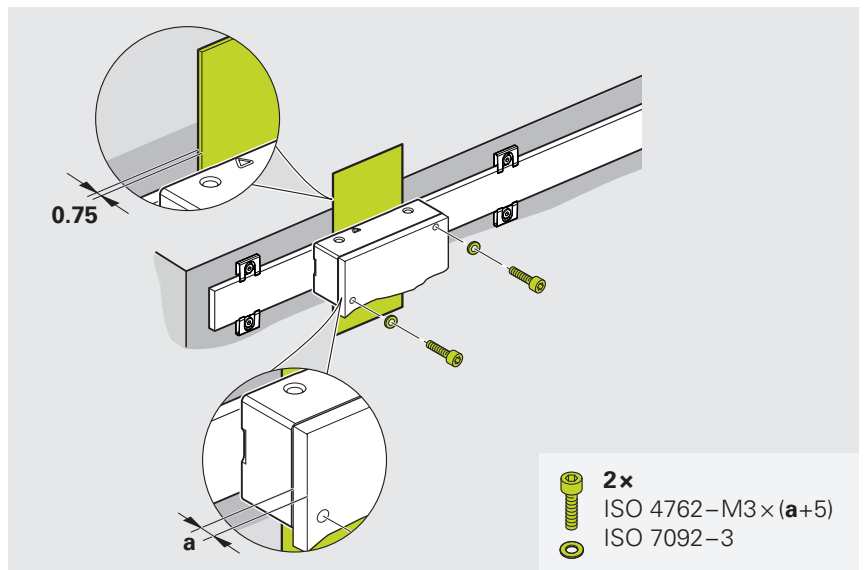

- ▶ Check the electrical resistance between the vacuum chamber and the attachment of the scanning head

**i** The electrical resistance between the vacuum chamber and the scanning head attachment must be  $< 1 \Omega$ .

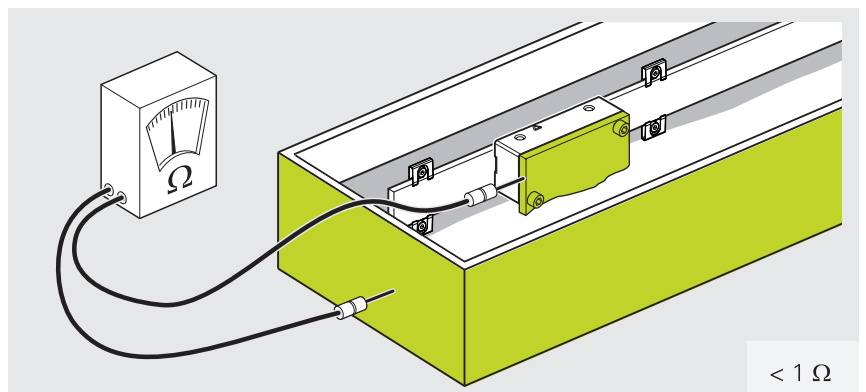

**Next step:** "Adjustment and diagnosis", Page 51

**Variant: Mounting with the holder at top**

The mounting variant described in this chapter refers to mounting of the scanning head with the holder at top.

An overview of the mounting variants is provided on Page 41.

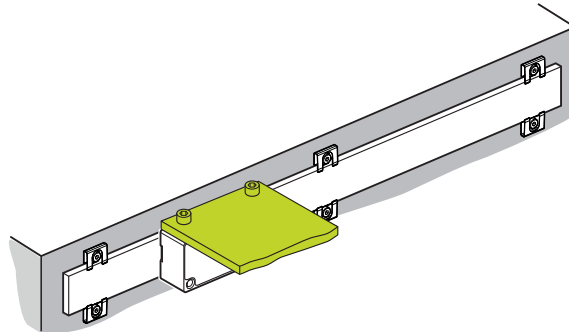

**Notes on mounting the scanning head with the holder at top**

**i** The tightening torques of the mounting screws are only valid for mounting on steel.

**NOTICE**

**Property damage due to the evacuation process!**

- ▶ Disconnect the encoder from the power supply before pumping air into or out of the vacuum chamber

**i** If necessary, clean the graduation and the scanning head with a lint-free cloth and isopropyl alcohol.

**NOTICE**

**Property damage due to unsuitable cleaning agents!**

- ▶ Use only isopropyl alcohol to clean the encoder
- ▶ Clean the encoder with a lint-free cloth

**NOTICE**

**Property damage due to mechanical stress!**

- ▶ Do not stretch or twist the vacuum cable

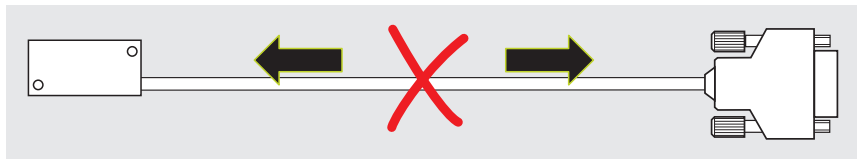
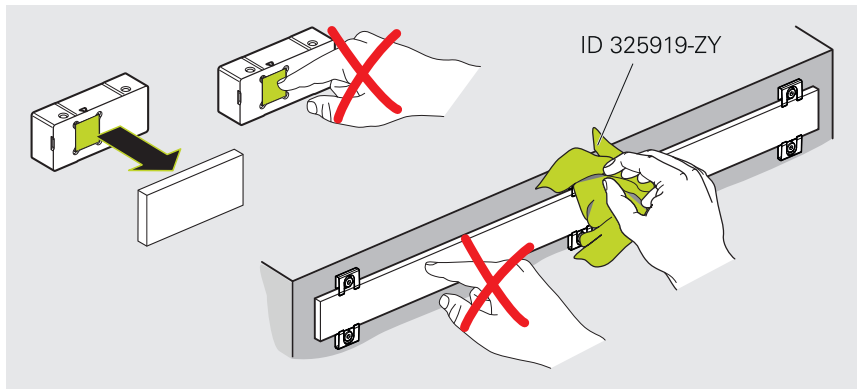

Pay attention to the mounting dimensions. Deviations from the mounting dimensions lead to imprecise measurement results during operation.

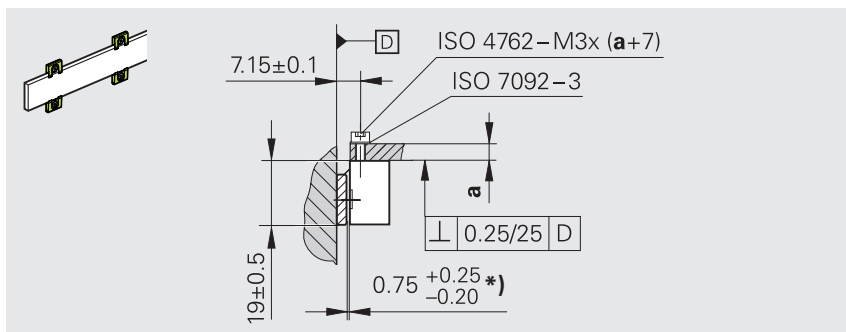

\*) Mounting clearance between the scanning head and graduation.

### Materials and tools

For this task, the following materials and tools are needed:

#### Included in delivery

- Spacer shim

#### To be provided separately

- Two screws (ISO 4762-M3x(a+7))
- Two washers (ISO 7092-3)
- Torque wrench (hexagon socket for 2.5 mm)

**Mounting the scanning head**

- ▶ If necessary, remove the protective cap from the scanning head

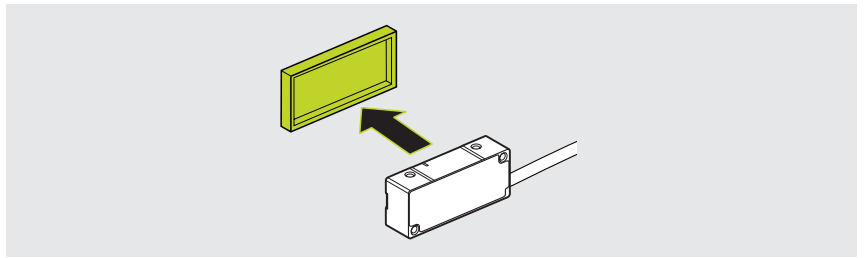

- ▶ Prepare the spacer shim

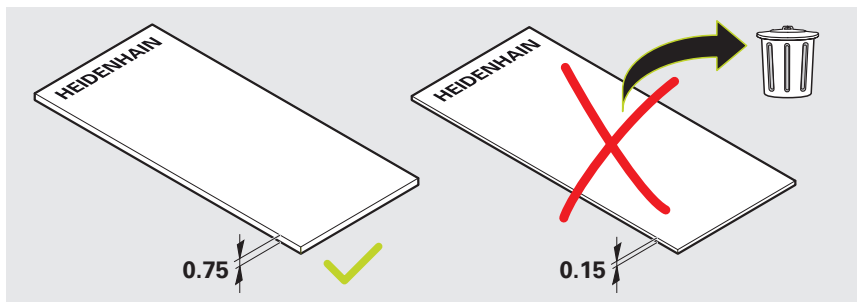

**i** Do not insert the spacer shim near the fixing clamps.

- ▶ Use the spacer shim to set the mounting clearance
- ▶ Lightly tighten the screws on the scanning head
- ▶ Remove the spacer shim

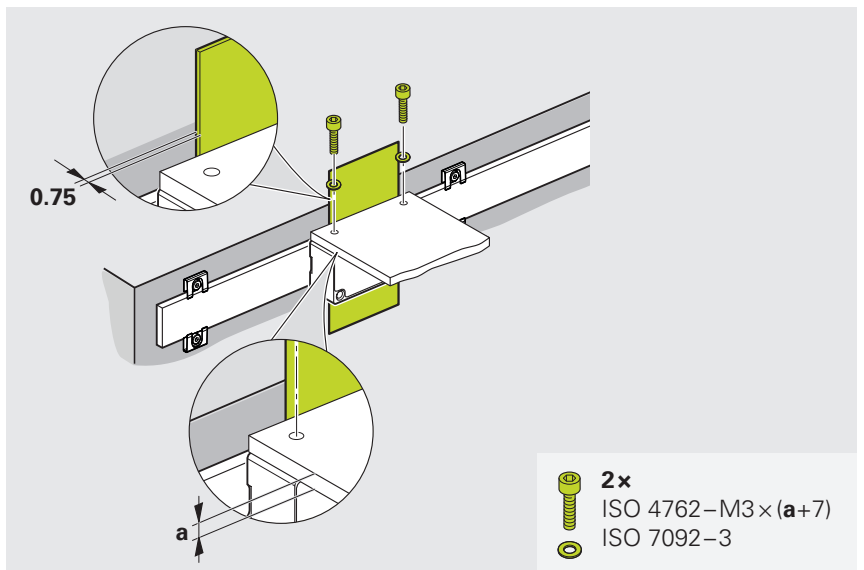

- ▶ Check the electrical resistance between the vacuum chamber and the attachment of the scanning head

**i** The electrical resistance between the vacuum chamber and the scanning head attachment must be  $< 1 \Omega$ .

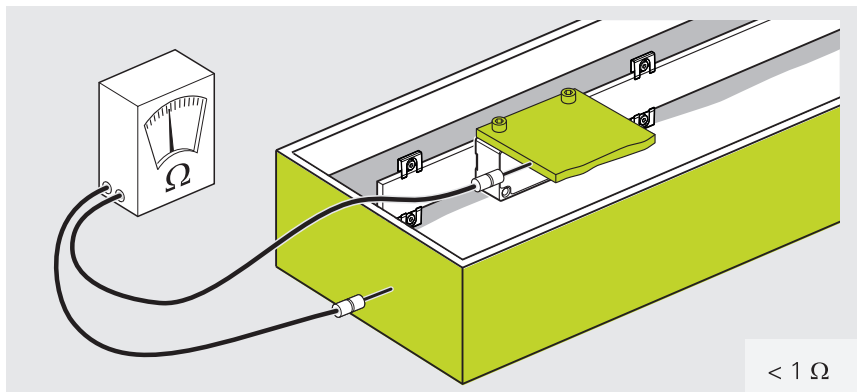

**Next step:** "Adjustment and diagnosis", Page 51

### Variant: Mounting with the holder at bottom

The mounting variant described in this chapter refers to mounting of the scanning head with the holder at bottom.

An overview of the mounting variants is provided on Page 41.

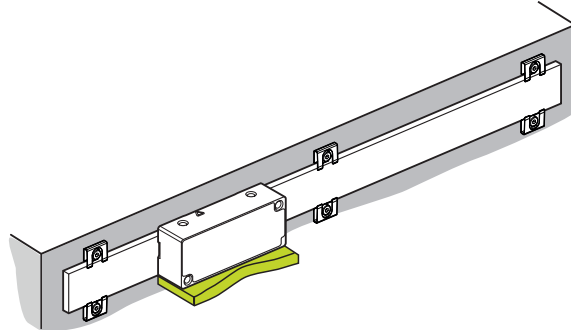

### Notes on mounting the scanning head with the holder at bottom

- i** The tightening torques of the mounting screws are only valid for mounting on steel.

#### NOTICE

#### Property damage due to the evacuation process!

- ▶ Disconnect the encoder from the power supply before pumping air into or out of the vacuum chamber

- i** If necessary, clean the graduation and the scanning head with a lint-free cloth and isopropyl alcohol.

#### NOTICE

#### Property damage due to unsuitable cleaning agents!

- ▶ Use only isopropyl alcohol to clean the encoder
- ▶ Clean the encoder with a lint-free cloth

#### NOTICE

#### Property damage due to mechanical stress!

- ▶ Do not stretch or twist the vacuum cable

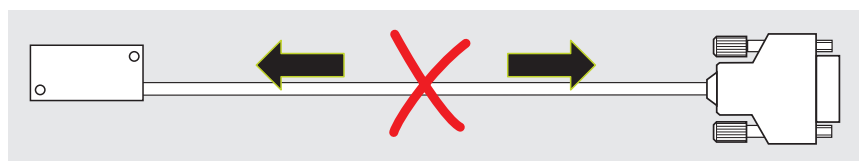
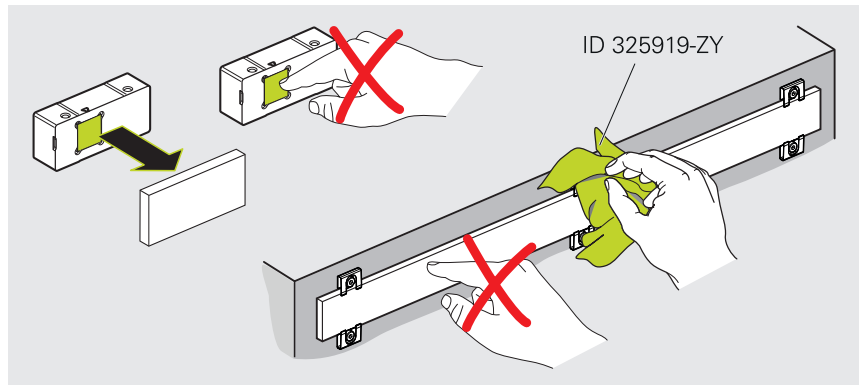

Pay attention to the mounting dimensions. Deviations from the mounting dimensions lead to imprecise measurement results during operation.

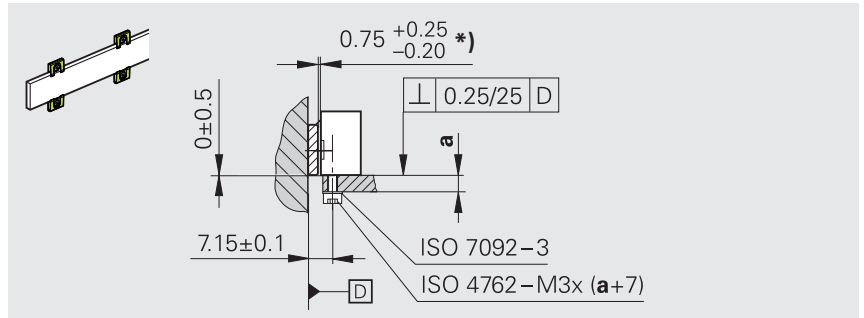

\*) Mounting clearance between the scanning head and graduation.

### Materials and tools

For this task, the following materials and tools are needed:

#### Included in delivery

- Spacer shim

#### To be provided separately

- Two screws (ISO 4762-M3x(a+7))
- Two washers (ISO 7092-3)
- Torque wrench (hexagon socket for 2.5 mm)

### Mounting the scanning head

- ▶ If necessary, remove the protective cap from the scanning head

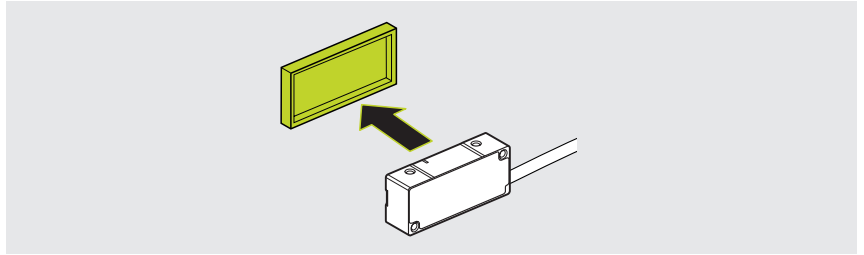

- ▶ Prepare the spacer shim

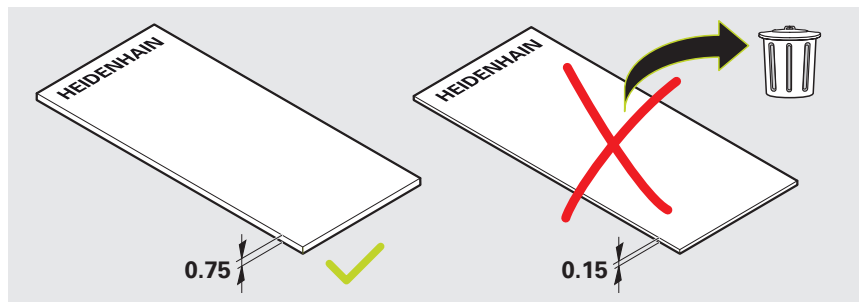

**i** Do not insert the spacer shim near the fixing clamps.

- ▶ Use the spacer shim to set the mounting clearance
- ▶ Lightly tighten the screws on the scanning head
- ▶ Remove the spacer shim

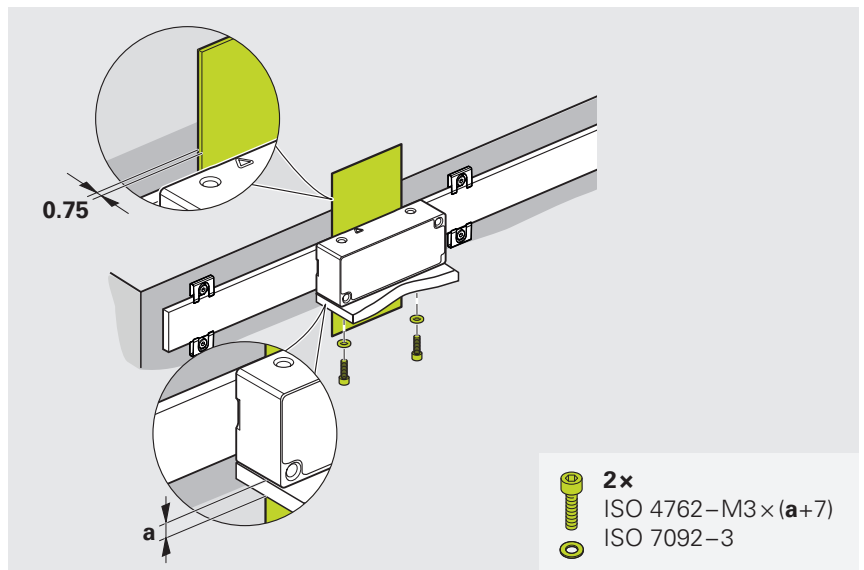

- ▶ Check the electrical resistance between the vacuum chamber and the attachment of the scanning head

**i** The electrical resistance between the vacuum chamber and the scanning head attachment must be  $< 1 \Omega$ .

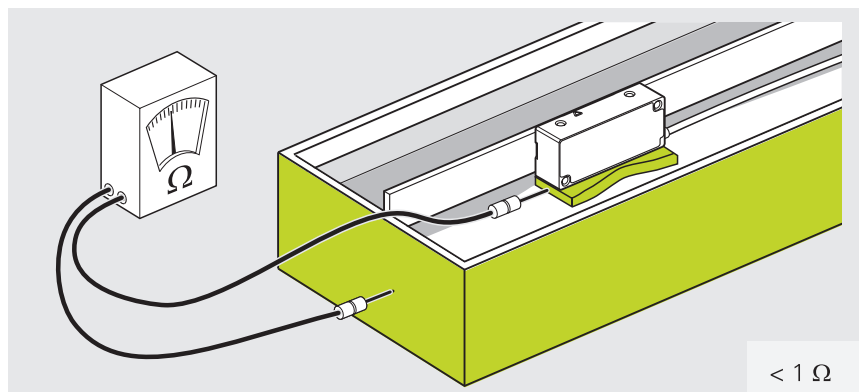

**Next step:** "Adjustment and diagnosis", Page 51

## 5 Adjustment and diagnosis

This chapter describes the continuity test, as well as the adjustment and diagnosis with the PWM 21 and the Adjusting and Testing Software (ATS).

### 5.1 Requirements and notes

The PWM 21 testing device together with the Adjusting and Testing Software (ATS) serves for the diagnosis and adjustment of HEIDENHAIN encoders.

The following components are needed:

- PWM 21
- ATS: version 3.2.xx and later provide integrated local encoder database for automatic encoder detection

The ATS software is available for download free of charge from [www.heidenhain.com/service/downloads/software/](http://www.heidenhain.com/service/downloads/software/).



For more information, see the **Exposed Linear Encoders** brochure.

- ▶ [www.heidenhain.com/documentation](http://www.heidenhain.com/documentation)
- ▶ Enter the document ID **208960**



For more information, see the associated **Adjusting and Testing Software** documentation.

- ▶ [www.heidenhain.com/documentation](http://www.heidenhain.com/documentation)
- ▶ Enter the document ID **543734**

### 5.2 Continuity check

#### Materials and tools

For this mounting step, the following materials and tools are needed:

#### Included in delivery

#### To be provided separately

- Resistance measuring device

#### 5.2.1 Measuring the electrical resistance

- ▶ Check the electrical resistance between the connector housing and the machine



The electrical resistance between the connector housing and the machine must be  $< 1 \Omega$ .

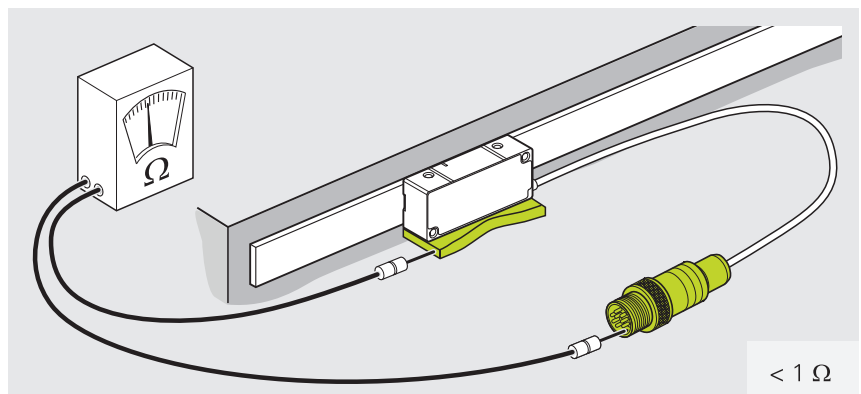

## 5.3 Connecting the encoder to the ATS

### 5.3.1 Connecting the encoder

- ▶ Connect the encoder to the PWM 21
- ▶ Switch on the PWM 21

### 5.3.2 Selecting the connection

---

#### Connection options

Connecting the encoder using its ID	Connecting the encoder manually
Recommended option with automatic determination of the measuring parameters.	Alternative option if the encoder cannot be connected using its ID.
<b>Page 53</b>	<b>Page 54</b>

---

### 5.3.3 Connecting the encoder using its ID

- ▶ Double-click **Connect the encoder** in the function menu
- ▶ The **Encoder selection** dialog opens

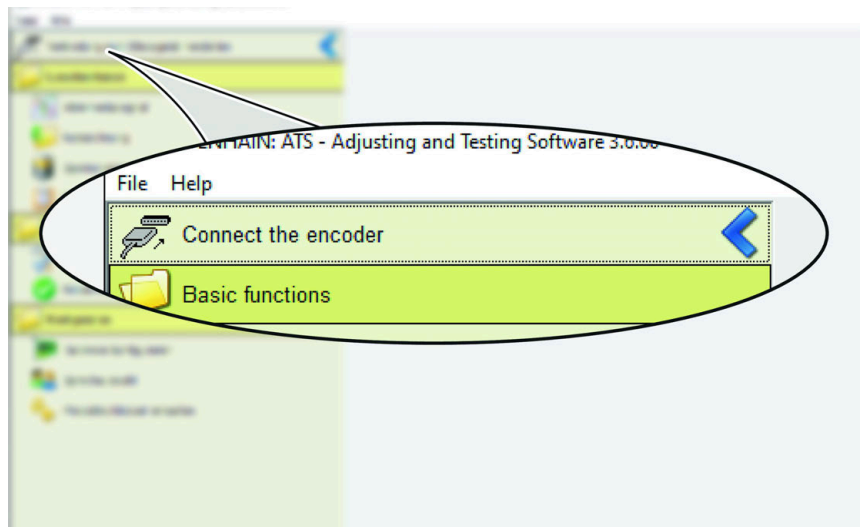

Function menu

- ▶ Enter the product ID in the **ID number** field
- ▶ The determined encoder parameters are shown in the **Encoder data** field.
- ▶ Click **Connect**
- ▶ The connection to the encoder is established.

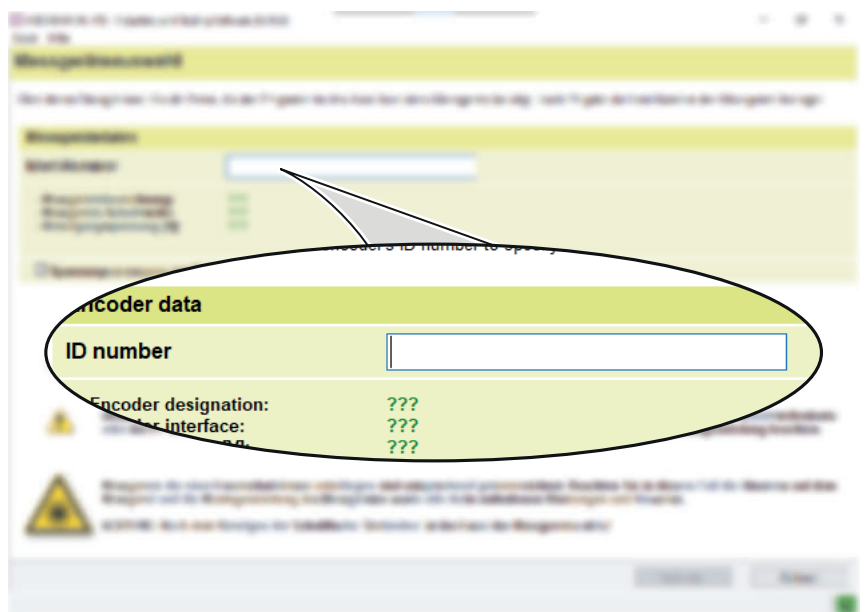

Encoder selection dialog

- ▶ **LIC 411, LIC 419x scanning head:** The **Function menu** opens.
- Next step:** "Mounting the LIC 411 or LIC 419x scanning head", Page 58
- ▶ **LIC 413 scanning head:** The **position display** opens.
- Next step:** "Mounting the LIC 413 scanning head", Page 60
- ▶ **LIC 413 scanning head in bus operation:** The **overview of bus addresses** opens.
- Next step:** "Mounting the LIC 413 scanning head in bus operation", Page 63



If you cannot connect the encoder using its ID, proceed as described in the "**Connecting the encoder manually**" chapter.

### 5.3.4 Connecting the encoder manually

- ▶ Double-click **Connect the encoder** in the function menu
- ▶ The **Encoder selection** dialog opens.

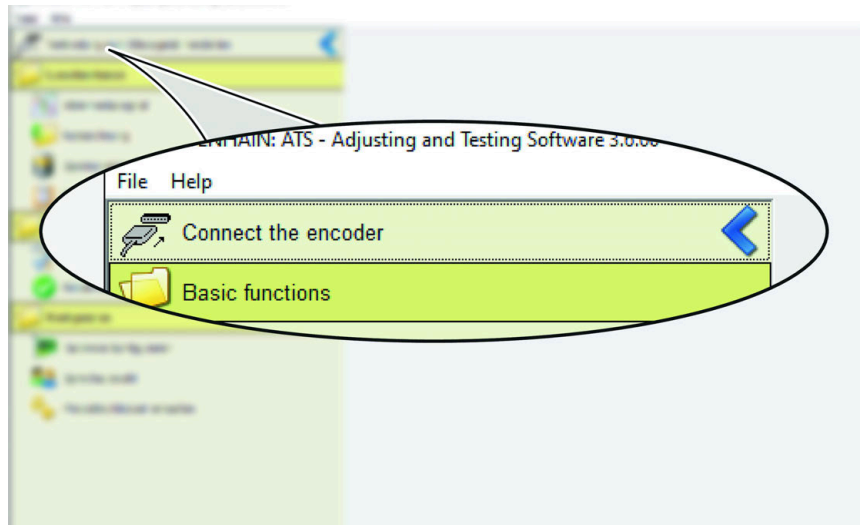

Function menu

- ▶ Click **Manual Settings**
- ▶ The **Encoder selection** dialog opens.

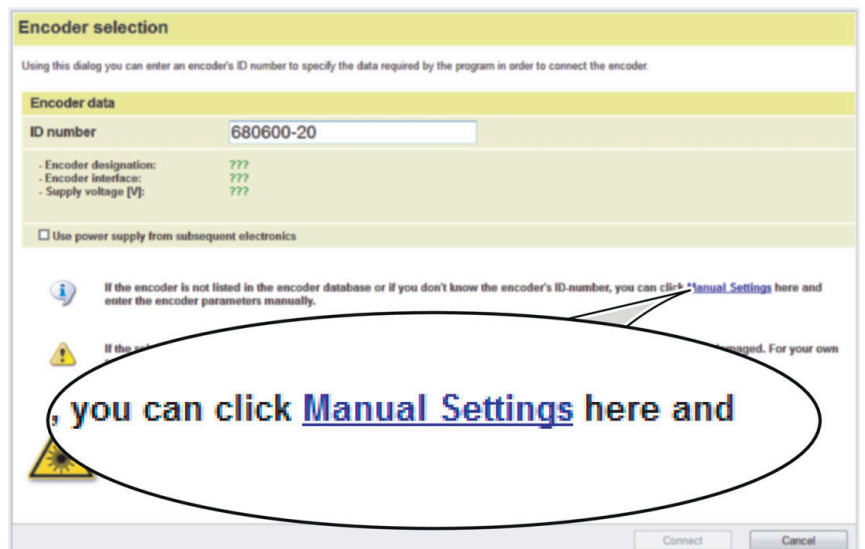

Encoder selection dialog

- ▶ Follow the safety instructions
- ▶ Click **Next**
- ▶ The **Encoder selection** dialog opens.

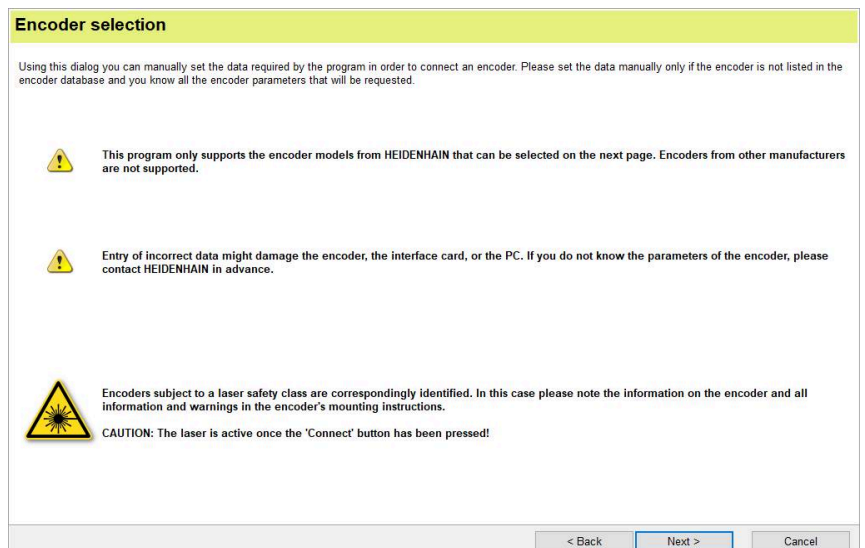

Encoder selection dialog



For more information on the supply voltage and interfaces, refer to the **Exposed Linear Encoders** brochure.

- ▶ [www.heidenhain.com/documentation](http://www.heidenhain.com/documentation)
- ▶ Enter the document ID **208960**

- ▶ Select the permissible encoder supply voltage in the **Encoder supply voltage** section
- ▶ If necessary, deactivate **Adjust voltage over sensor lines**
- ▶ Select the interface type in the **Encoder interface** section  
If the EnDat 3 interface is selected, the mounting code is entered automatically. Click **Next** and continue with the chapter "Mounting the LIC 413 scanning head" or "Mounting the LIC 413 scanning head in bus operation".

If a different interface was selected:

- ▶ Click **Mounting code**
- ▶ The **Entry of ATS code** message appears.
- ▶ Click **OK**
- ▶ The **Encoder selection** dialog with the mounting code opens.

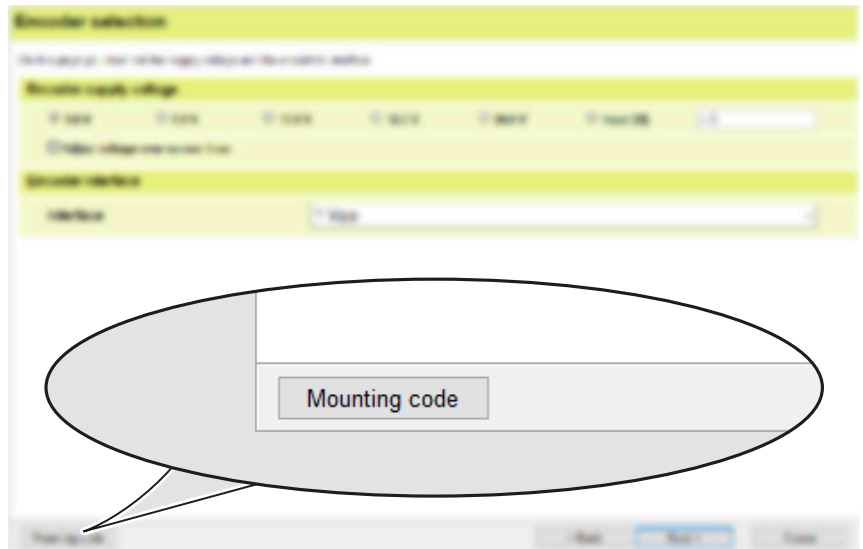

Encoder selection dialog

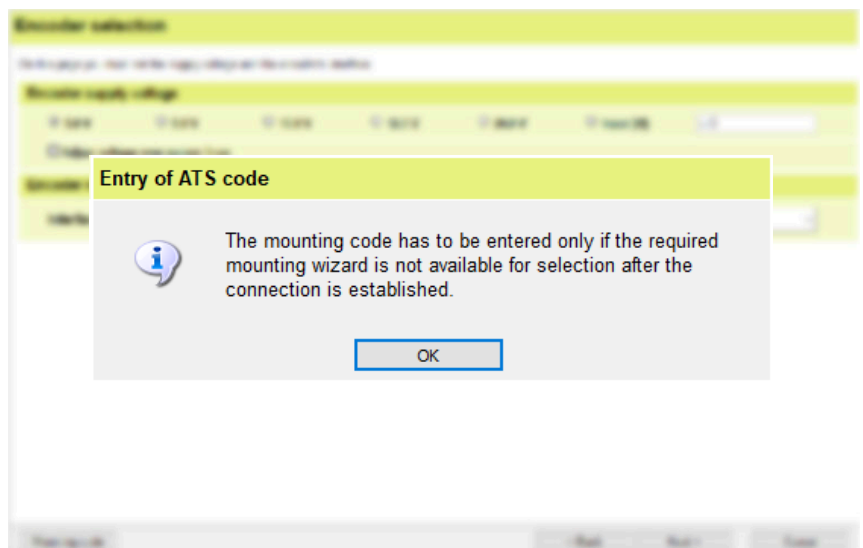

The **Entry of ATS code** note

- ▶ For the **Mounting code**, enter the value:  
LIC 411: E001-A005 LIC 413: E003-A005 LIC 419x: E002-A005
- ▶ Click **Next**
- > The **Encoder selection** dialog with the encoder data opens.

Encoder selection dialog with the mounting code

## NOTICE

### Property damage due to incorrect data settings!

Incorrect data settings can cause damage to the interface card or the PC.

- ▶ Before connecting the encoder, check the encoder data

Encoder interface:	EnDat22	EnDat3
Supply voltage [V]:	5.0	12.0
Voltage adjustment:	No	No

- ▶ Click **Connect**
- > The connection to the encoder is established.

The **Encoder selection** dialog with the encoder data

- > **LIC 411, LIC 419x scanning head:** The **Function menu** opens.
- Next step:** "Mounting the LIC 411 or LIC 419x scanning head", Page 58
- > **LIC 413 scanning head:** The **position display** opens.
- Next step:** "Mounting the LIC 413 scanning head", Page 60
- > **LIC 413 scanning head in bus operation:** The **overview of bus addresses** opens.
- Next step:** "Mounting the LIC 413 scanning head in bus operation", Page 63

## 5.4 Mounting the scanning head

### 5.4.1 Selecting the scanning head

Scanning head variants		
LIC 411, LIC 419x	LIC 413	LIC 413 in bus operation
Scanning head with the EnDat 2.2, Fanuc, Mitsubishi, Panasonic or Yaskawa interface <b>Page 58</b>	Scanning head with the EnDat 3 interface <b>Page 60</b>	Scanning head with the EnDat 3 interface in bus operation <b>Page 63</b>

## 5.4.2 Mounting the LIC 411 or LIC 419x scanning head

### Using the mounting wizard

- ▶ Double-click **LIC mounting**
- ▶ The **LIC mounting wizard** opens.

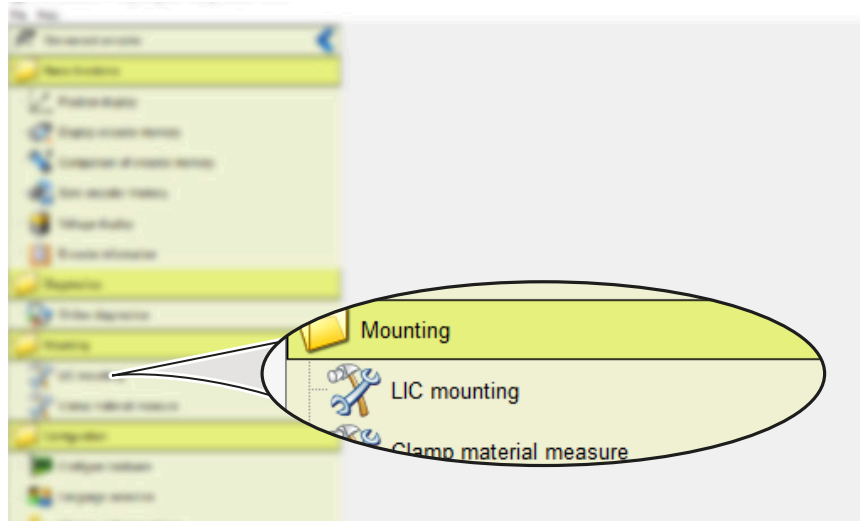

### Function menu

Adjust the scanning head in the area of the midpoint of the measuring length.

- ▶ Set the absolute track to the maximum attainable bar length by slightly turning the scanning head
- ▶ Tighten the screws with the specified torque
- ▶ Click **Next**
- ▶ The **Step 2: Verify mounting** dialog opens.

**i** If an error message occurs, it is because the maximum incremental signal was not achieved.

- ▶ Repeat the installation

- ▶ Traverse the scanning head over the entire measuring length
- ▶ Ensure that the minimum markers remain within the green ranges

**i** If the green ranges are not reached or if strong signal fluctuations occur over the entire measuring length, check the mounting tolerances and inspect for contamination.

- ▶ Click **Exit**
- ▶ The **Installation successful** message appears.

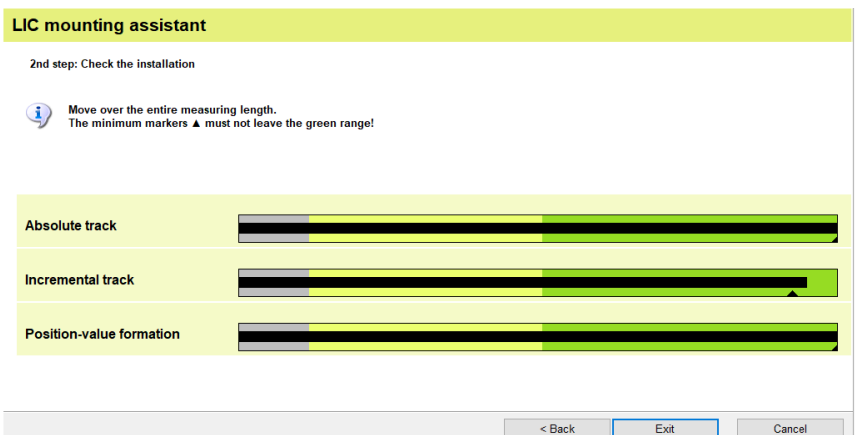
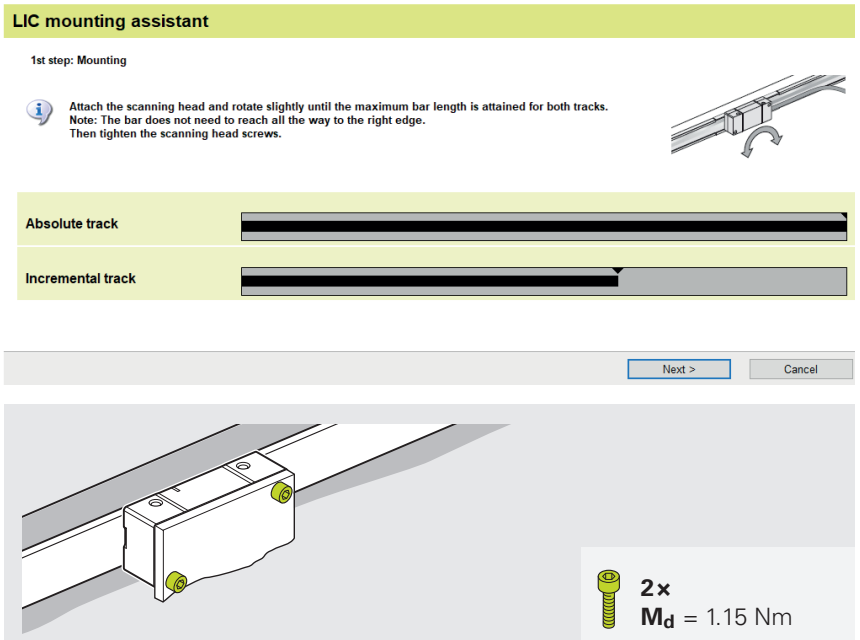

- ▶ Click **OK**
- > The **Function menu** opens.
- > Mounting was successfully concluded.

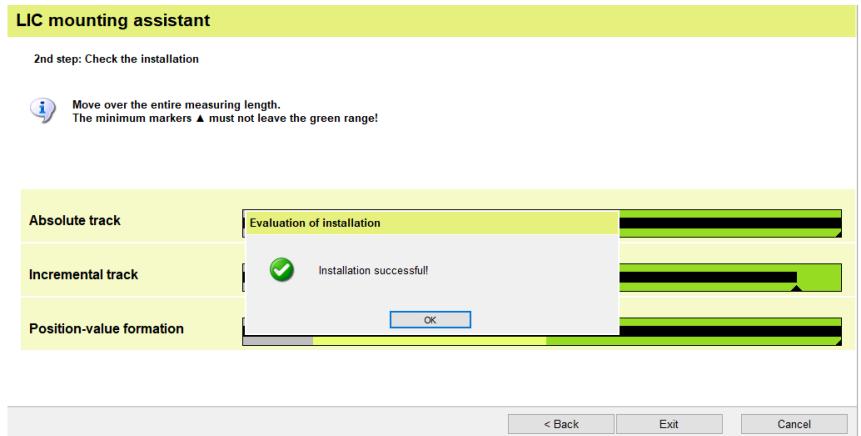

- ▶ Double-click **Disconnect encoder**

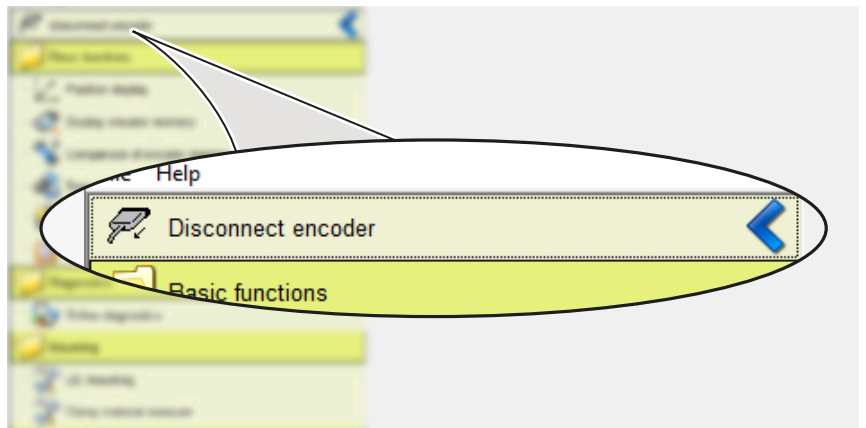

**Next step:** "Final steps", Page 66

### 5.4.3 Mounting the LIC 413 scanning head

#### Using the mounting wizard

- ▶ Click **Wizards**

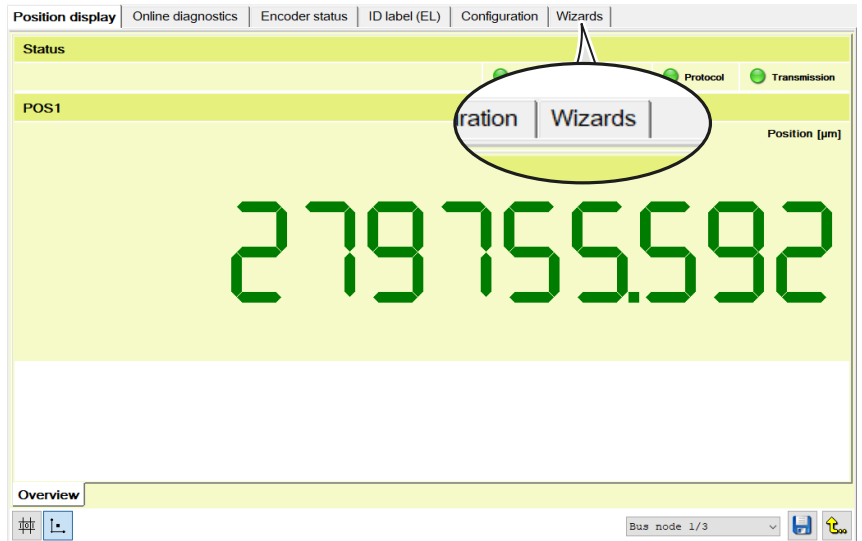

- ▶ Click **LIC mounting wizard**
- ▶ The **Step 1: Mounting** dialog opens.

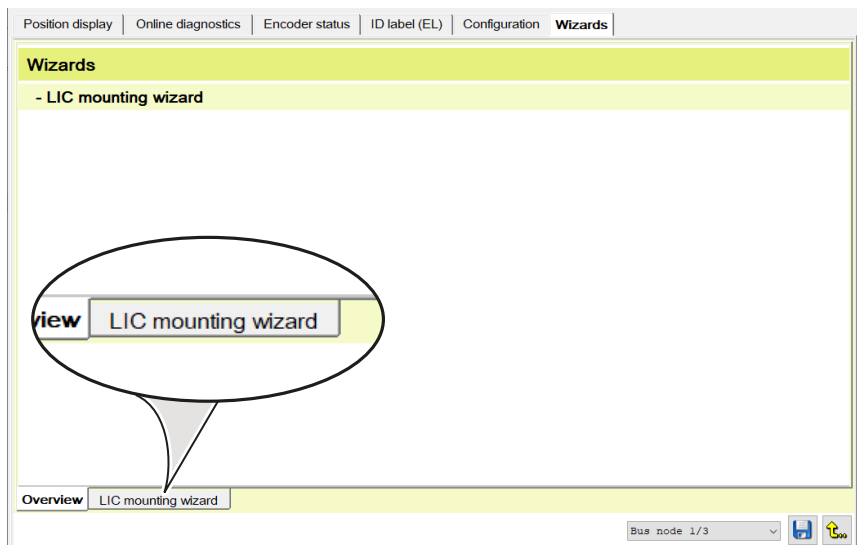

Adjust the scanning head in the area of the midpoint of the measuring length.

- ▶ Set the absolute track to the maximum attainable bar length by slightly turning the scanning head
- ▶ Tighten the screws with the specified torque
- ▶ Click **Next**
- ▶ The **Step 2: Verify mounting** dialog opens.

**i** If an error message occurs, it is because the maximum incremental signal was not achieved.

- ▶ Repeat the installation

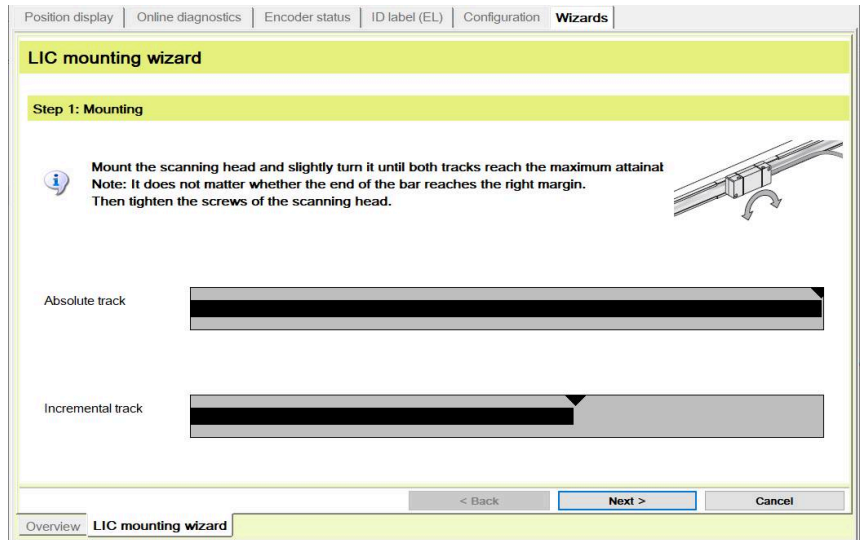

- ▶ Traverse the scanning head over the entire measuring length
- ▶ Ensure that the minimum markers remain within the green ranges

**i** If the green ranges are not reached or if strong signal fluctuations occur over the entire measuring length, check the mounting tolerances and inspect for contamination.

- ▶ Click **Next**
- ▶ The **Installation successful** message appears.

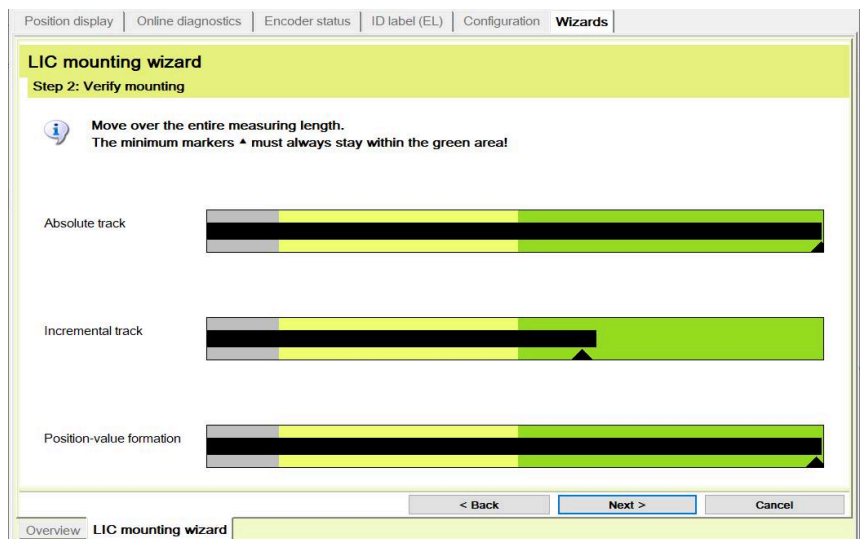

- ▶ Click **Exit**
- > The **Function menu** opens.
- > Mounting was successfully concluded.

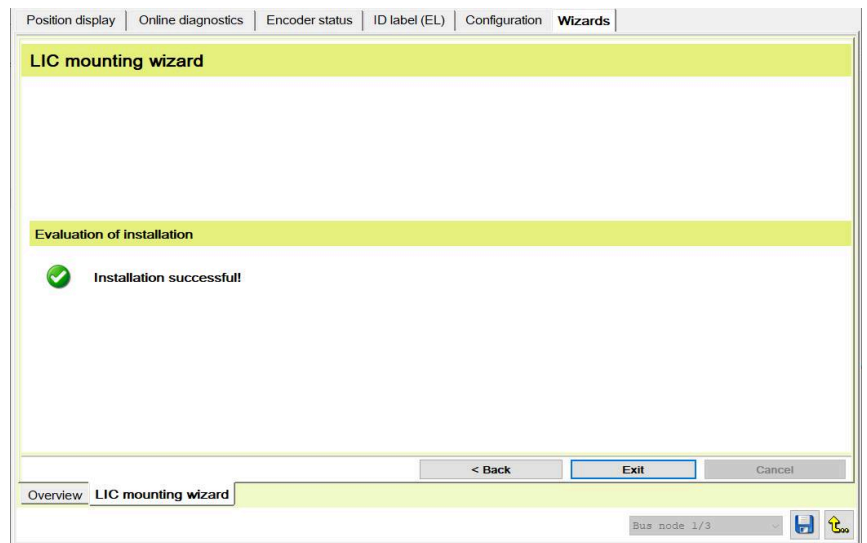

- ▶ Double-click **Disconnect encoder**

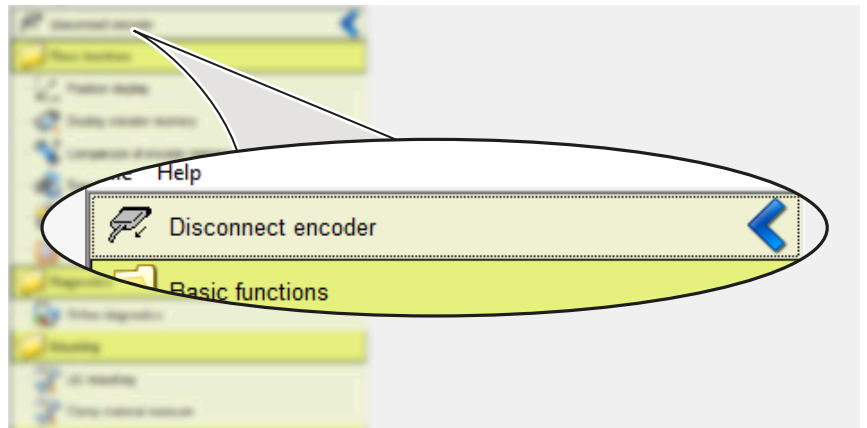

**Next step:** "Final steps", Page 66

## 5.4.4 Mounting the LIC 413 scanning head in bus operation

### Using the mounting wizard

- ▶ Click **OK**
- The **position display** appears.

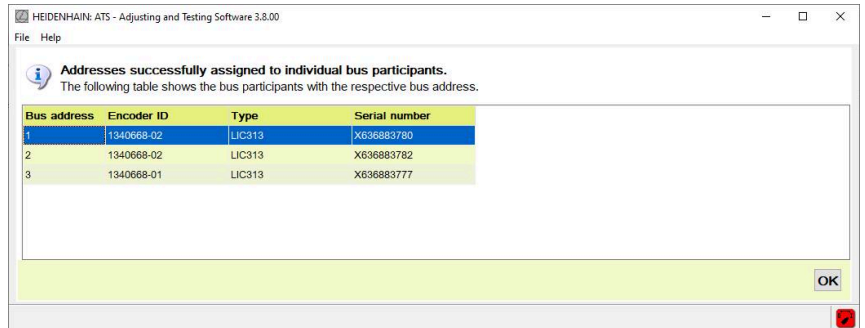

- ▶ Click **Wizards**

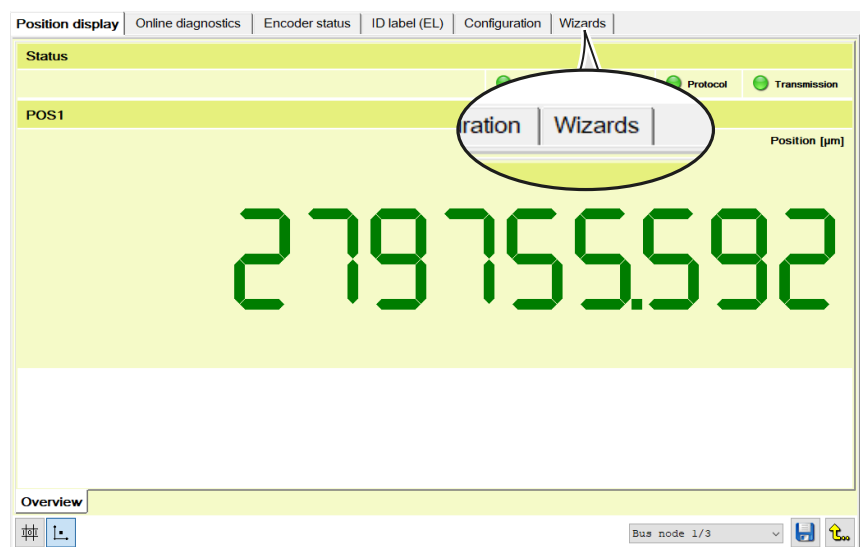

- ▶ Select **Bus node 1/3**

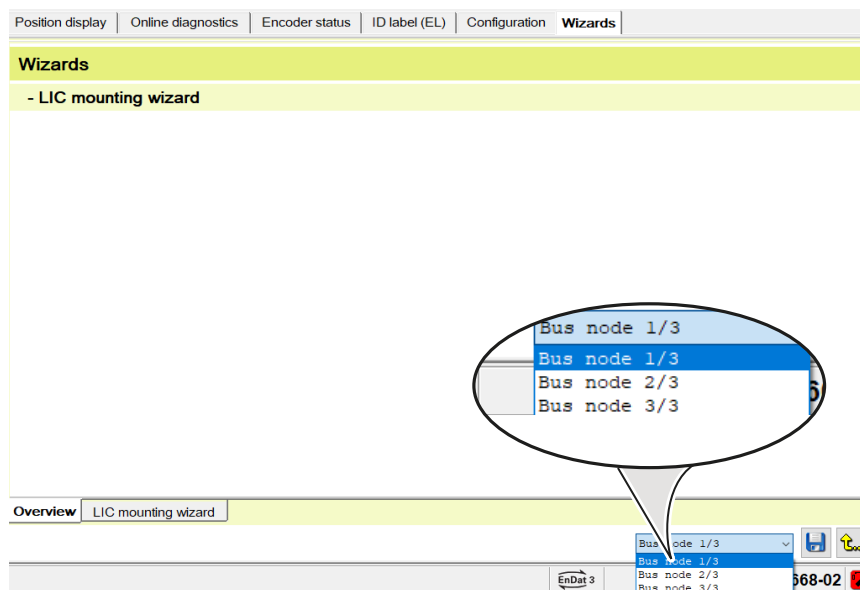

- ▶ Click **LIC mounting wizard**
- ▶ The **Step 1: Mounting** dialog opens.

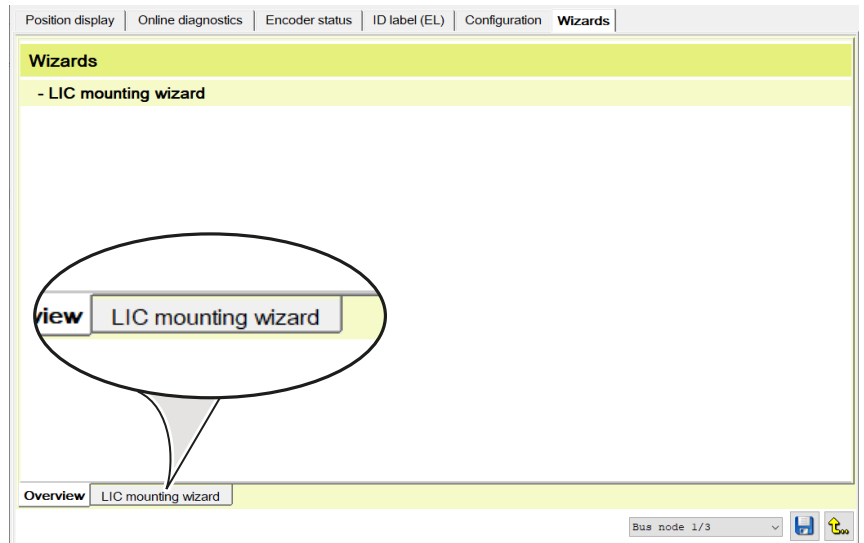

Adjust the scanning head in the area of the midpoint of the measuring length.

- ▶ Set the absolute track to the maximum attainable bar length by slightly turning the scanning head
- ▶ Tighten the screws with the specified torque
- ▶ Click **Next**
- ▶ The **Step 2: Verify mounting** dialog opens.

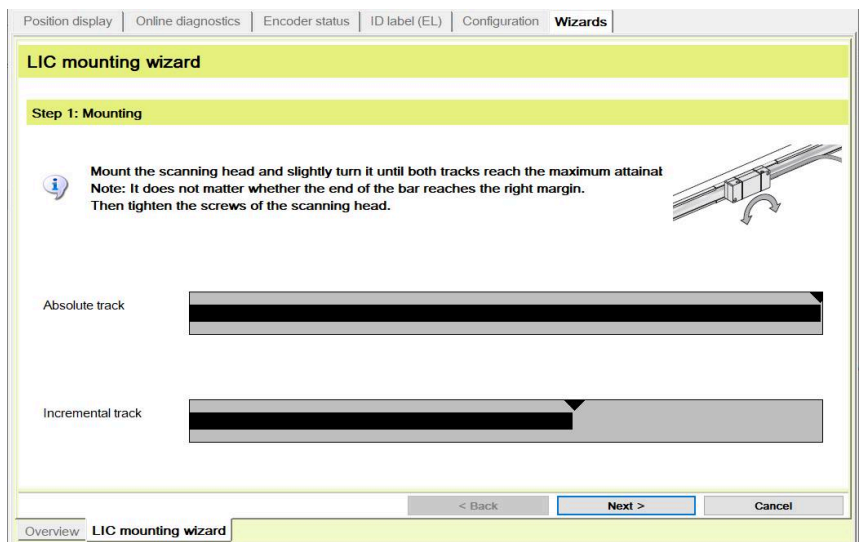

**i** If an error message occurs, it is because the maximum incremental signal was not achieved.

- ▶ Repeat the installation



- ▶ Traverse the scanning head over the entire measuring length
- ▶ Ensure that the minimum markers remain within the green ranges

**i** If the green ranges are not reached or if strong signal fluctuations occur over the entire measuring length, check the mounting tolerances and inspect for contamination.

- ▶ Click **Next**
- ▶ The **Installation successful** message appears.
- ▶ Click **Exit**
- ▶ The **Function menu** opens.
- ▶ Mounting was successfully concluded.

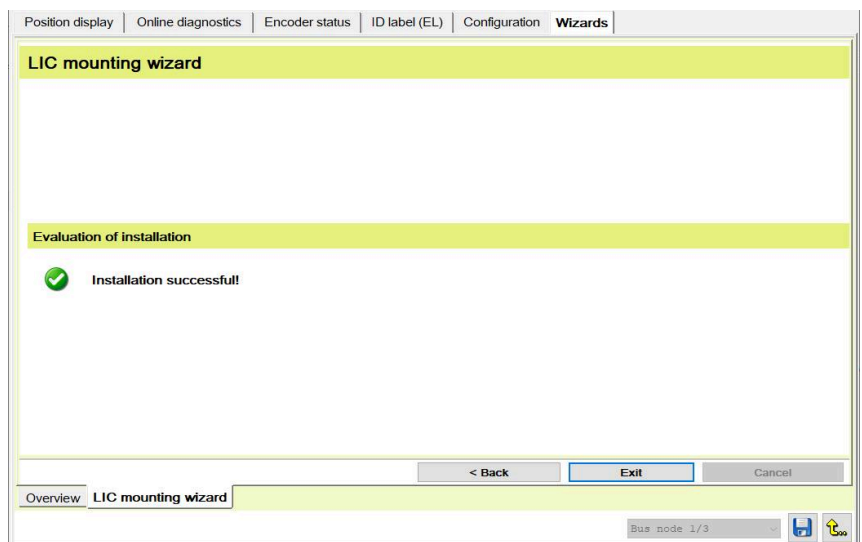

- ▶ Follow the same procedure for **Bus node 2/3** and **Bus node 3/3**
- ▶ Double-click **Disconnect encoder**

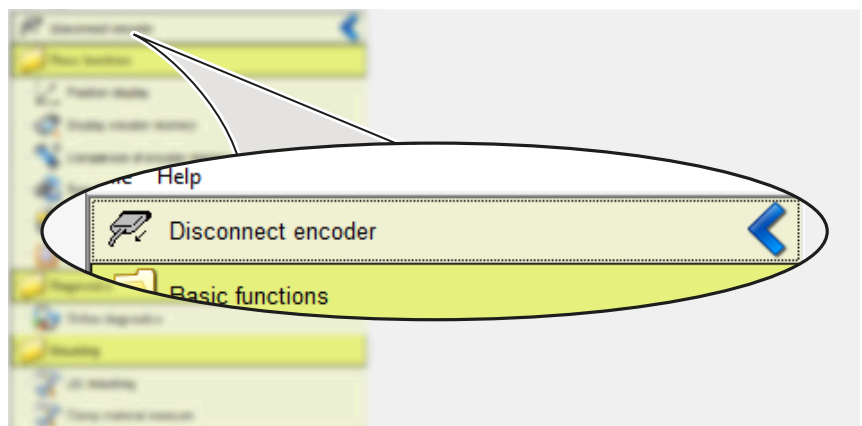

**Next step:** "Final steps", Page 66

## 6 Final steps

### 6.1 Connecting the encoder with the downstream electronics

#### WARNING

##### Danger of electric shock due to plug connections under voltage

Connecting and disconnecting live cables and plug connections in the equipment can result in death or serious injury.

- Only connect and disconnect cables and plug connections when no current is flowing through them
- Disconnect the downstream electronics from power before connecting the encoder
- For cables without connectors, pay attention to the pin layout

- ▶ Connect the encoder to the downstream electronics

#### NOTICE

##### Property damage resulting from incorrect routing of the connecting cable!

Connecting cables may become damaged as a result of incorrect routing.

- ▶ Observe the maximum permissible bend radii
- ▶ Do not cross connecting cables in drag chains
- ▶ Route connecting cables professionally



For more information on the cable characteristics and cable routing, refer to the **Cables and Connectors** brochure.

- ▶ [www.heidenhain.com/documentation](http://www.heidenhain.com/documentation)
- ▶ Enter the document ID **1206103**



For more information on the pin layouts, refer to the **Cables and Connectors** brochure.

- ▶ [www.heidenhain.com/documentation](http://www.heidenhain.com/documentation)
- ▶ Enter the document ID **1206103**



For more information on sources of interference, refer to the **Interfaces of HEIDENHAIN Encoders** brochure.

- ▶ [www.heidenhain.com/documentation](http://www.heidenhain.com/documentation)
- ▶ Enter the document ID **1078628**

## 7 Removal

This chapter describes the disassembly of the product.

### 7.1 Safety precautions regarding removal

#### WARNING

##### **Live plug connections!**

If you disengage plug connections while the equipment is under power, this may result in fatal accidents or severe personal injury.

- ▶ Do not engage or disengage any connecting elements while the product is under power

#### WARNING

##### **Moving machine parts!**

Risk of injury due to moving machine parts depending on the installation location and the application

- ▶ Observe all of the machine manufacturer's notes on working on the machine, e.g., always disconnect the machine from the power supply

#### CAUTION

##### **Fragile carrier material of the graduation!**

Risk of injury from splinters and sharp edges of the carrier material

- ▶ Wear protective gloves and safety goggles
- ▶ Do not bend or deform the measuring standard excessively

### 7.2 Removing the scanning head

- ▶ Remove the scanning head in the reversed sequence of mounting. **Further information:** "Mounting the scanning head", Page 27

### 7.3 Removing the scale



Further information can be found in the **Disassembly Instructions**.

- ▶ [www.heidenhain.com/documentation](http://www.heidenhain.com/documentation)
- ▶ Enter the document ID **1185755**

# HEIDENHAIN

## DR. JOHANNES HEIDENHAIN GmbH

Dr.-Johannes-Heidenhain-Straße 5

**83301 Traunreut, Germany**

☎ +49 8669 31-0

☎ +49 8669 32-5061

info@heidenhain.de

**Technical support** ☎ +49 8669 32-1000

**Measuring systems** ☎ +49 8669 31-3104

service.ms-support@heidenhain.de

**NC support** ☎ +49 8669 31-3101

service.nc-support@heidenhain.de

**NC programming** ☎ +49 8669 31-3103

service.nc-pgm@heidenhain.de

**PLC programming** ☎ +49 8669 31-3102

service.plc@heidenhain.de

**APP programming** ☎ +49 8669 31-3106

service.app@heidenhain.de

**www.heidenhain.com**