

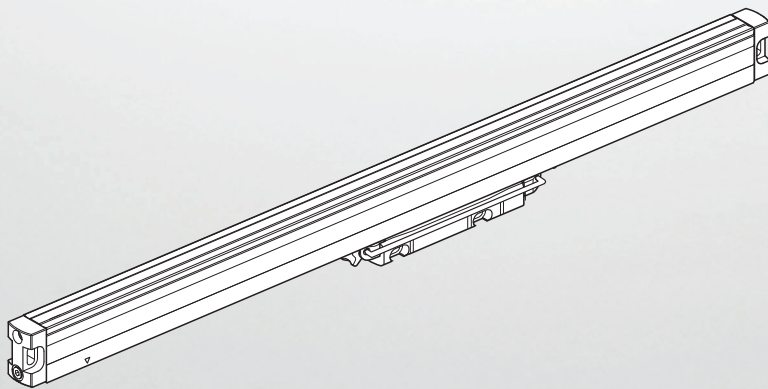

HEIDENHAIN



LC 416

LC 496

With 14A End Blocks

Mounting Instructions

English (en)
03/2025

Table of contents

1	Basic information.....	4
1.1	Validity of the documentation.....	4
1.2	Target groups of the Mounting Instructions.....	4
1.3	Notes on reading the documentation.....	5
1.4	Symbols and fonts used for marking text.....	6
1.5	Notes in this documentation.....	7
1.6	Units and tolerances.....	7
2	Safety.....	8
2.1	Personnel qualification.....	8
2.2	General safety precautions.....	8
3	Items supplied and accessories.....	10
3.1	What is included?.....	10
3.2	Mounting accessories.....	11
3.2.1	Accessories for all mounting variants.....	11
3.2.2	For mounting with a mounting spar.....	11
3.2.3	For mounting with end blocks.....	12
3.2.4	Accessories for mounting the pre-assembled cable.....	12
3.2.5	Accessories for connecting the sealing-air supply.....	12
4	Mounting.....	13
4.1	Requirements and notes.....	13
4.1.1	Functional safety.....	15
4.2	Function and handling of the shipping brace.....	16
4.2.1	Moving the scanning unit.....	16
4.2.2	Removing the shipping brace.....	16
4.2.3	Mounting the shipping brace.....	17
4.3	Choosing the mounting variant.....	19
4.4	Mounting with end blocks.....	20
4.4.1	Variant: cable outlet on the left, equal mounting surfaces (ELG).....	21

4.4.2	Variant: cable outlet on the right, equal mounting surfaces (ERG).....	23
4.4.3	Variant: cable outlet on the left, opposite mounting surfaces (ELE).....	25
4.4.4	Variant: cable outlet on the right, opposite mounting surfaces (ERE).....	27
4.5	Mounting with mounting spar.....	29
4.5.1	Mounting the mounting spar.....	29
4.5.2	Variant: cable outlet on the left, equal mounting surfaces (MLG).....	31
4.5.3	Variant: cable outlet on the right, equal mounting surfaces (MRG).....	33
4.5.4	Variant: cable outlet on the left, opposite mounting surfaces (MLE).....	35
4.5.5	Variant: cable outlet on the right, opposite mounting surfaces (MRE).....	37
5	Final steps.....	39
5.1	Continuity check.....	39
5.1.1	Requirements and notes.....	39
5.1.2	Materials and tools.....	39
5.1.3	Resistance measurement.....	39
5.2	Using sealing air (optional).....	40
5.2.1	Requirements and notes.....	40
5.2.2	Materials and tools.....	40
5.2.3	Connecting compressed air to the encoder.....	40
5.3	Connecting the cable.....	42
5.3.1	Prerequisites and notes.....	42
5.3.2	Materials and tools.....	43
5.3.3	Connecting the adapter cable to the encoder.....	43
6	Removal.....	45
6.1	Safety precautions regarding removal.....	45
6.2	Removing the encoder.....	45

1 Basic information

This chapter contains information about the product and the Mounting Instructions.

1.1 Validity of the documentation

These Mounting Instructions apply to LC 416, LC 496 with 14A-type end blocks.

► Before using the documentation, check whether the documentation and product model match. The designation of the product is printed on the ID label. The ID label is provided on the scale unit.

ID label

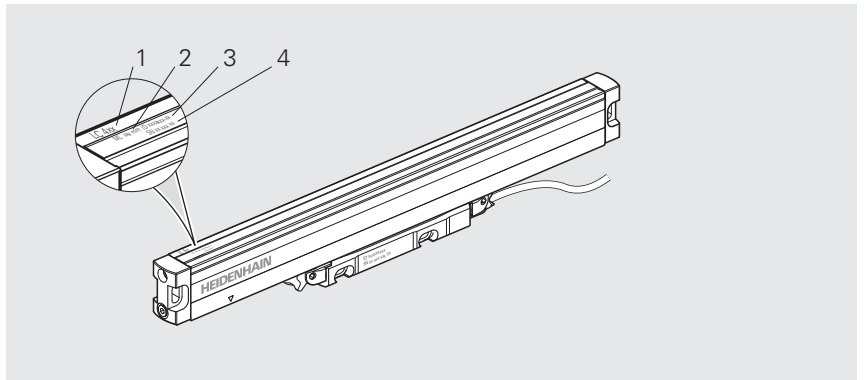

ID label with legend

- 1** Product name
- 2** Measuring length (ML)
- 3** Product ID / Part number (ID)
- 4** Serial number (SN)

1.2 Target groups of the Mounting Instructions

The Mounting Instructions must be read and observed by every person who performs any of the following tasks:

- Design
- Mounting
- Removal

1.3 Notes on reading the documentation

WARNING

Fatal accidents, personal injury or property damage caused by non-compliance with the documentation!

Failure to comply with the documentation may result in fatal accidents, personal injury or property damage.

- ▶ Read the documentation carefully from beginning to end
- ▶ Keep the documentation for future reference

The following table lists the various parts of the documentation in their order of reading priority.

Document type	Description
Addendum	An Addendum supplements or supersedes the corresponding contents of the Operating Instructions and, if applicable, of the Mounting Instructions. If an Addendum is included in the shipment, it has the highest priority for reading. All other documentation content retains its validity.
Operating Instructions	The Operating Instructions contain all of the information and safety instructions for the proper and intended operation of the device. The Operating Instructions (English language version) are included in delivery and can also be downloaded in other languages from www.heidenhain.com/documentation . The Operating Instructions must be read prior to initial operation of the product. The Operating Instructions have the second highest priority for reading.
Mounting Instructions	The Mounting Instructions contain all the information and safety precautions needed for the proper mounting and installation of a product. The Mounting Instructions are not included in delivery and must be downloaded from www.heidenhain.com/documentation . The Mounting Instructions have the third highest priority for reading.

Would you like any changes, or have you found any errors?

We are continuously striving to improve our documentation for you. Please help us by sending your suggestions to the following e-mail address:

userdoc@heidenhain.de

1.4 Symbols and fonts used for marking text

In these instructions the following symbols and fonts are used for marking text:

Format	Meaning
▶ ...	Identifies an action and the result of this action
> ...	Example: <ul style="list-style-type: none"> ▶ Tilt the shipping brace to remove it (c) > The shipping brace has been removed now
■ ...	Identifies an item of a list
■ ...	Example: <ul style="list-style-type: none"> ■ Solid contaminants: class 3 ■ Max. pressure dew point: class 4

1.5 Notes in this documentation

Safety precautions

Precautionary statements warn of hazards in handling the product and provide information on their prevention. Precautionary statements are classified by hazard severity and divided into the following groups:

DANGER

Danger indicates hazards for persons. If you do not follow the avoidance instructions, the hazard **will result in death or severe injury**.

WARNING

Warning indicates hazards for persons. If you do not follow the avoidance instructions, the hazard **could result in death or serious injury**.

CAUTION

Caution indicates hazards for persons. If you do not follow the avoidance instructions, the hazard **could result in minor or moderate injury**.

NOTICE

Notice indicates danger to material or data. If you do not follow the avoidance instructions, the hazard **could result in property damage**.

Informational notes

Informational notes ensure reliable and efficient operation of the product. Informational notes are divided into the following groups:



The information symbol indicates a **tip**.
A tip provides important additional or supplementary information.



The book symbol indicates a **cross reference**.
A cross reference leads to external documentation, for example: further documentation from HEIDENHAIN or another supplier.

1.6 Units and tolerances

Unless otherwise specified, the dimensions stated in these Mounting Instructions are given in millimeters.

Unless otherwise specified, the tolerances stated in these Mounting Instructions conform to ISO 8015 and ISO 2768 standards.

mm



Tolerancing ISO 8015
ISO 2768:1989-mH
≤ 6 mm: ±0.2 mm

2 Safety

This chapter provides important safety information needed for the proper mounting and installation of the product.

2.1 Personnel qualification

Mounting, initial configuration and removal must be conducted by a qualified specialist under compliance with local safety regulations.

2.2 General safety precautions

WARNING

Danger of electric shock due to connection to unsuitable downstream electronics!

If you connect unsuitable downstream electronics to the product, fatal accidents or severe personal injuries can occur.

- ▶ Connect the product only to downstream electronics whose supply voltage comes from PELV systems

WARNING

Live plug connections!

If you disengage plug connections while the equipment is under power, this may result in fatal accidents or severe personal injury.

- ▶ Do not engage or disengage any connecting elements while the product is under power

WARNING

Risk of injury from damaged or worn components!

Safety functions can fail if damaged or worn components are installed. Failed safety functions can result in death or serious injury.

- ▶ Inspect the component for damage
- ▶ Do not use any damaged or worn components
- ▶ In case of replacement, repair the thread
- ▶ Use new screws, spring pins and nuts
- ▶ Secure screws and nuts with suitable material-bonding anti-rotation lock

NOTICE

Property damage due to mechanical stress!

- ▶ Do not drop the product or subject it to major vibration
- ▶ Do not expose the product to mechanical stress
- ▶ Do not change the physical structure of the product

NOTICE**Property damage due to electrical stress!**

- ▶ Do not engage or disengage any connecting elements while the product is under power
- ▶ Do not touch the contacts of the plug connections

NOTICE**Electrostatic discharge (ESD)!**





This product contains electrostatically sensitive components that can be destroyed by electrostatic discharge (ESD).

- ▶ It is essential to observe the safety precautions for handling ESD-sensitive components
- ▶ Never touch connector pins without ensuring proper grounding
- ▶ Wear a grounded ESD wristband when handling the connections of the product

3 Items supplied and accessories

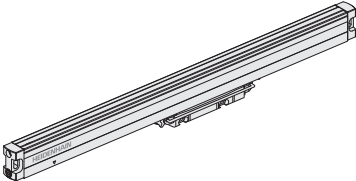
This chapter contains information on the items supplied and the available accessories of the product.

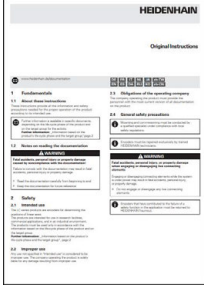
3.1 What is included?

Component	Figure
Encoder with shipping brace	
Attachment parts	
Operating Instructions	
Product placard sticker	
Quality Inspection Certificate	

3.2 Mounting accessories

The following accessories can be ordered separately from HEIDENHAIN.

 For more information on the listed products, please refer to the applicable Mounting Instructions and the **Linear Encoders for Numerically Controlled Machine Tools** brochure.

- ▶ www.heidenhain.com/documentation
- ▶ Enter the document ID **571470**

3.2.1 Accessories for all mounting variants

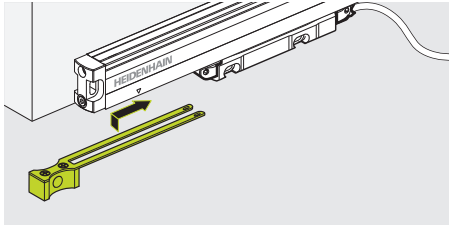
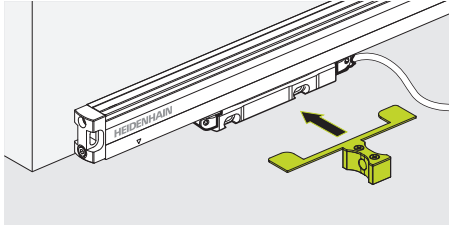
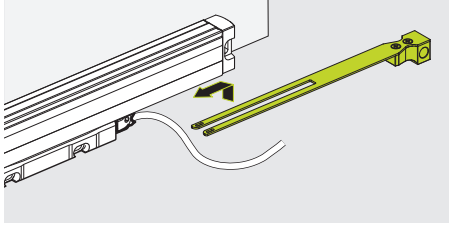
Designation	ID	Figure
<p>Mounting gauge and check gauges</p> <p>For setting and checking the gap between the scale unit and the scanning unit</p>	737748-xx	
<p>Mounting gauge and check gauges</p> <p>For setting and checking the gap between the scale unit and the scanning unit</p>	1211239-xx	
<p>Mounting gauge and check gauges</p> <p>For checking the minimum distance between the scale unit and the scanning unit</p>	1211268-xx	

3.2.2 For mounting with a mounting spar

 For encoders of this version, we generally recommend using the mounting spar. With measuring lengths of more than 1240 mm, the encoders must be mounted using a mounting spar.

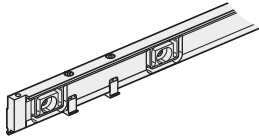
Designation	ID	Figure
<p>MSL 41 mounting spar</p> <p>To increase vibration resistance</p>	770902-xx	

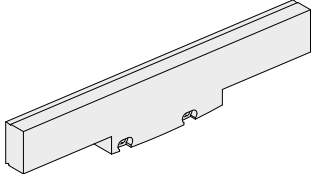
Designation	ID	Figure
Mounting aid for MSL 41 mounting spar For mounting with a mounting spar: for alignment of the mounting surface to which the scanning unit is attached	753853-01	

3.2.3 For mounting with end blocks

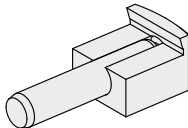
Designation	ID	Figure
Clamping elements To increase vibration resistance, the scale unit can additionally be fixed with the clamping elements if the cable outlet is on the right. This eliminates the need of a mounting spar for measuring lengths over 620 mm.	556975-01	

3.2.4 Accessories for mounting the pre-assembled cable

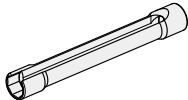
Designation	ID	Figure
Socket wrench Socket wrench with 1/4" connection for mounting the cable when the space is limited.	618965-02	

3.2.5 Accessories for connecting the sealing-air supply

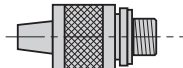
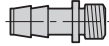
Designation	ID	Figure
Connecting piece for the scale unit Connecting piece for the scale unit of a linear encoder for a 6 mm x 1 mm pneumatic hose. The connecting piece has an integrated throttle that ensures flow quantities of 7 l/min at an input pressure of approx. $1 \cdot 10^5$ Pa (1 bar).	226270-02	
Connecting piece for scanning unit Connecting piece for the scanning unit of a linear encoder for a 6 mm x 1 mm pneumatic hose. The connecting piece has an integrated throttle that ensures flow quantities of 7 l/min at an input pressure of approx. $1 \cdot 10^5$ Pa (1 bar).	275239-01	

4 Mounting

This chapter describes the mounting requirements, different mounting variants, and all other tasks necessary when mounting.

4.1 Requirements and notes

Note that the mounting surface, as well as the surfaces of the scale unit and the scanning unit must be clean and free of paint, dust and grease.

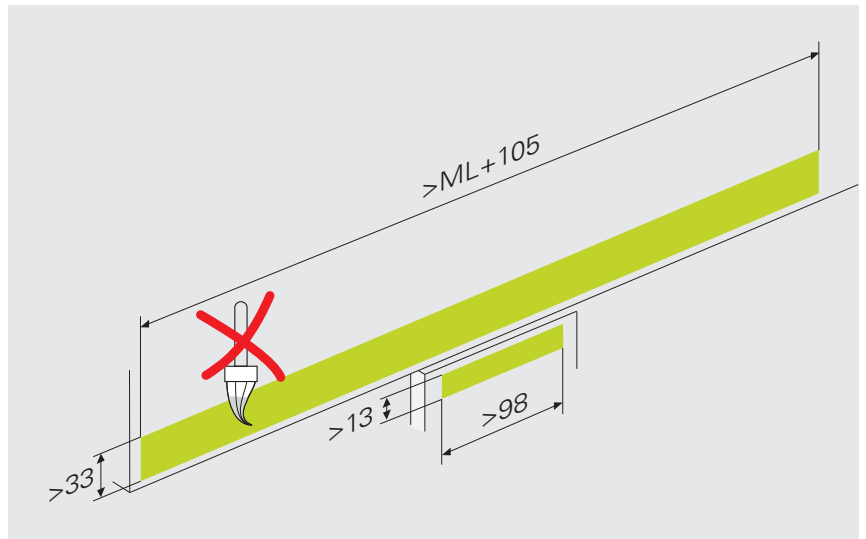

Mounting surface for mounting with end blocks

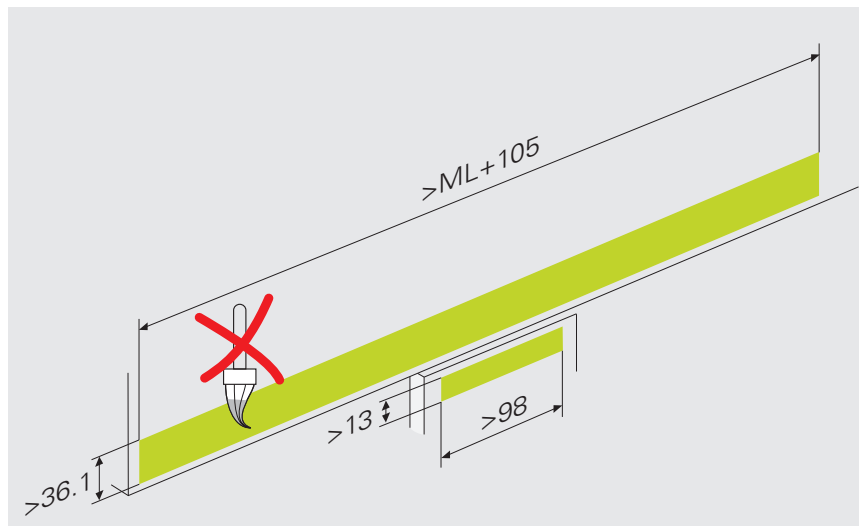

Mounting surface for mounting with mounting spar

S marks the beginning of the measuring length (**ML**).

S is reached when the arrows are above each other.

Move the scanning unit only within the specified measuring length.

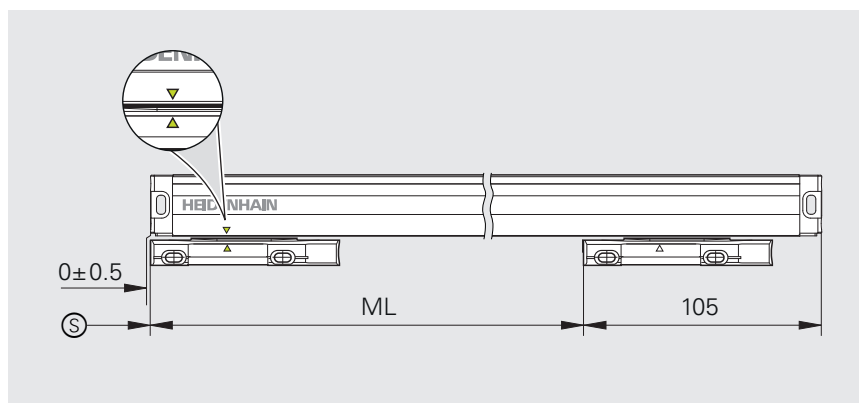

You can use one of the following aids to align the scale unit with the machine guideway **F**:

- Dial gauge
- Stop pins
- Stop edge

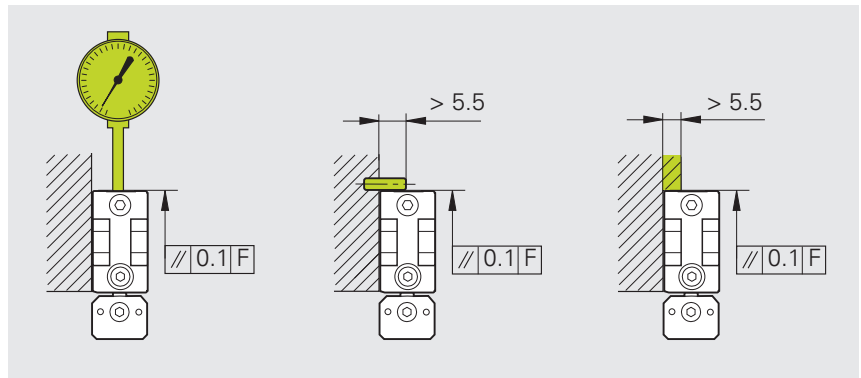

When mounting the device with a mounting spar, you can use one of the following aids to align the mounting spar with the machine guideway **F**:

- Dial gauge
- Stop pins
- Stop edge

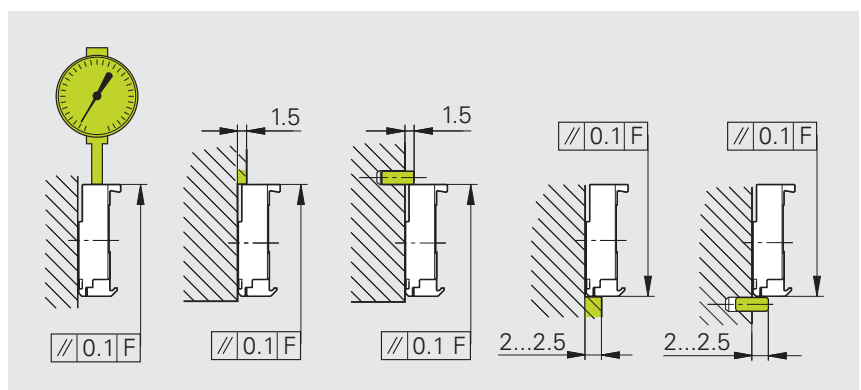

The items supplied with the encoder include clips for securing the nuts. To find out whether the clips are required for your mounting variant, please refer to the corresponding chapter in these Mounting Instructions.

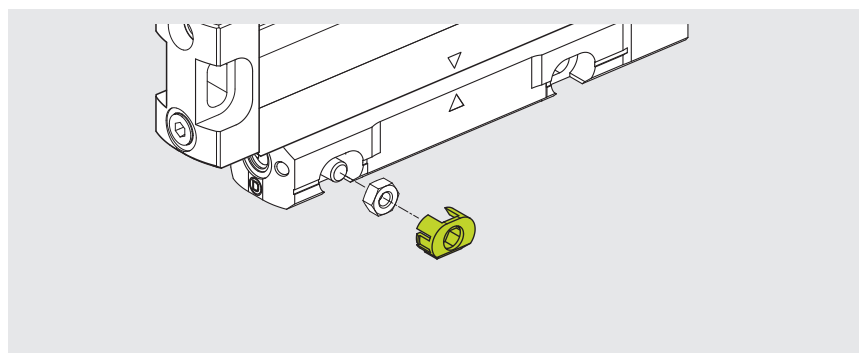

4.1.1 Functional safety

If the machine manufacturer requires fault exclusion for the loosening of the mechanical connection in order to use the encoder, a suitable anti-rotation lock must be used for the screw connections. Comply with the mounting temperature of 15 °C to 35 °C.



For more information, refer to the **Linear Encoders for Numerically Controlled Machine Tools** brochure.

- ▶ www.heidenhain.com/documentation
- ▶ Enter the document ID **571470**

4.2 Function and handling of the shipping brace

The shipping brace protects the encoder during transport and mounting. Remove the shipping brace only when necessary. The shipping brace helps you to align the device correctly and to maintain the mounting tolerances.

Materials and tools

For this task, the following materials and tools are needed:

Included in delivery

- Shipping brace (mounted)

To be provided separately

- 2.5 mm hexagon socket tool

Depending on the position of the moving part, the shipping brace is either locked or unlocked.

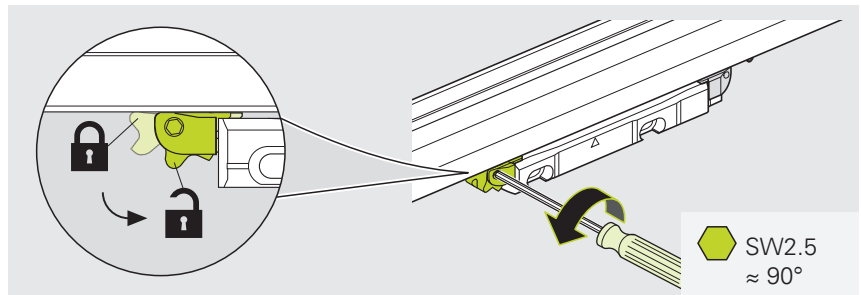

The locked shipping brace sets the specified dimensions.

When the shipping brace is locked, you can align adjustable machine parts with the scanning unit, as far as the rigidity of a plastic element permits.

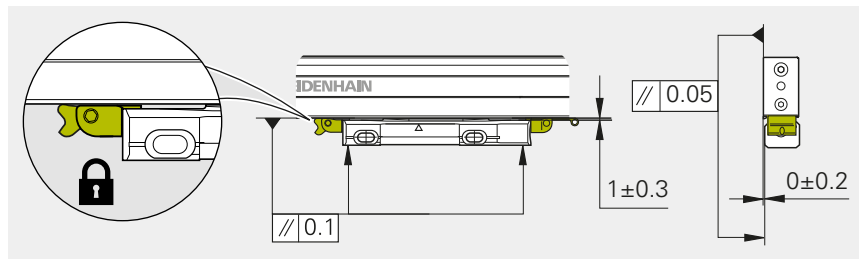

4.2.1 Moving the scanning unit

- Unlock the shipping brace before you move the scanning unit

i If the bracket is already removed, do not pull the scanning unit, but slide it as shown.

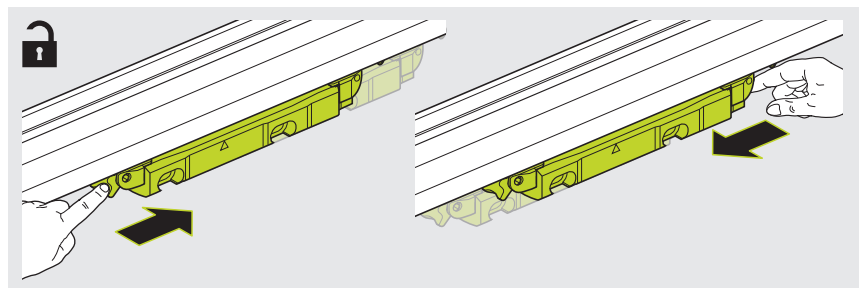

4.2.2 Removing the shipping brace

- Remove the bracket

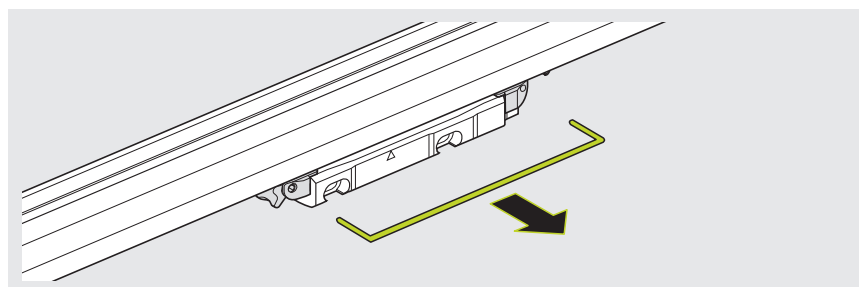

- ▶ Unlock the left-hand shipping brace with the hexagon socket tool

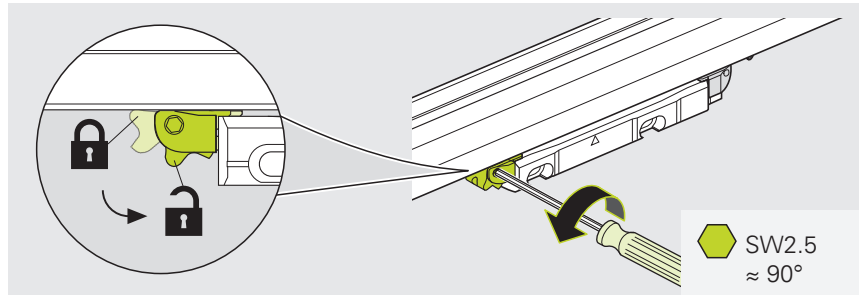

- ▶ Carefully slide away the shipping brace from the scanning unit to the left (a)
- ▶ Remove the shipping brace with a rotation to the right (b)
- ▶ The shipping brace has been removed (c)

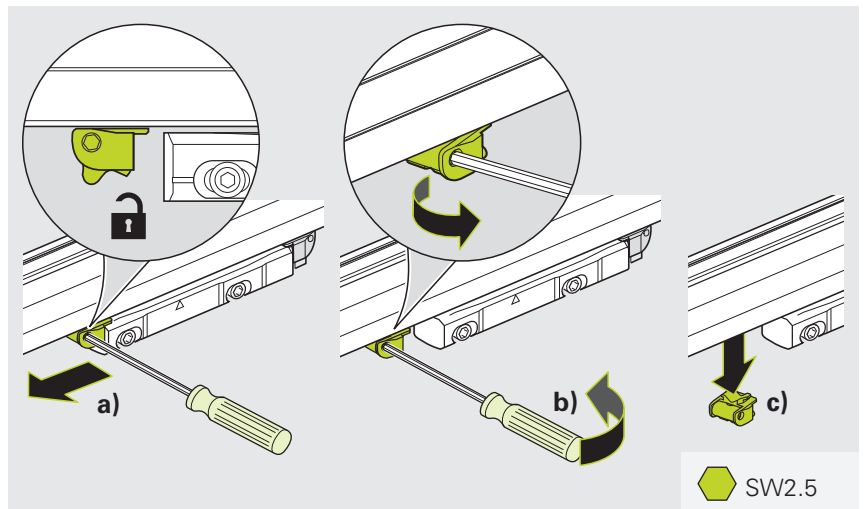

- ▶ Using the tool, pull off the shackle of the right-hand shipping brace from the scanning unit (d)
- ▶ Remove the shipping brace with a rotation to the right (e)
- ▶ The shipping brace has been removed (f)

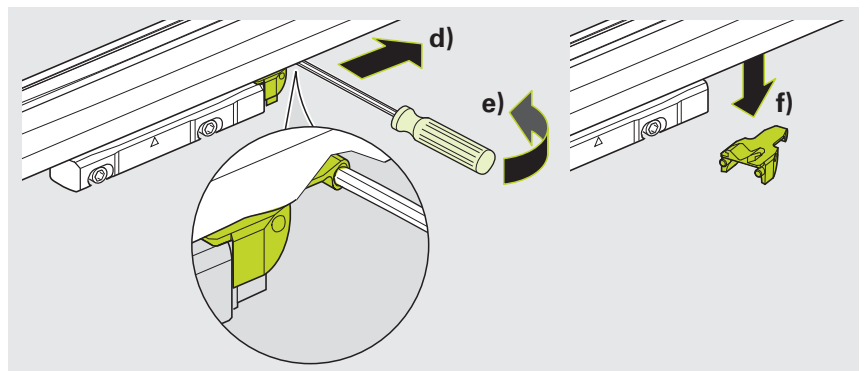

4.2.3 Mounting the shipping brace

- ▶ Insert the shipping brace into the scale housing (a)
- ▶ Fasten the shipping brace with a slight rotation in the scale housing (b)
- ▶ Slide the shipping brace into the scanning unit (c)
- ▶ Lock the shipping brace with the hexagon socket tool (d)

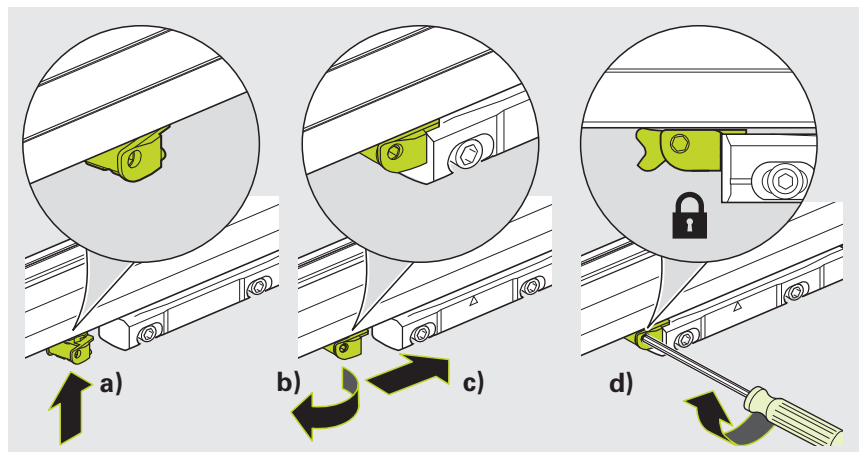

- ▶ Insert the shipping brace into the scale housing (**e**)
- ▶ Fasten the shipping brace with a slight rotation in the scale housing (**f**)
- ▶ Slide the shipping brace into the scanning unit (**g**)
- ▶ Attach the bracket of the shipping brace
- ▶ The shipping brace has been mounted.

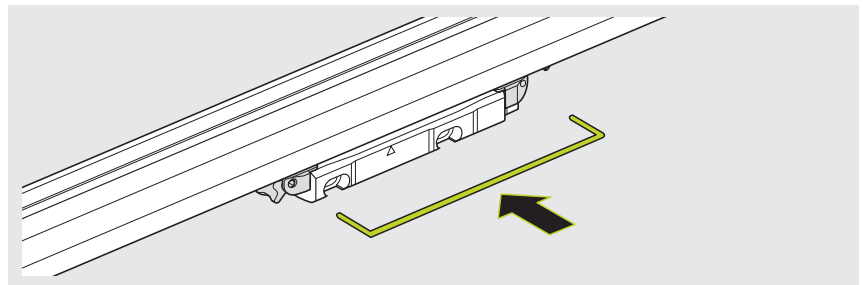
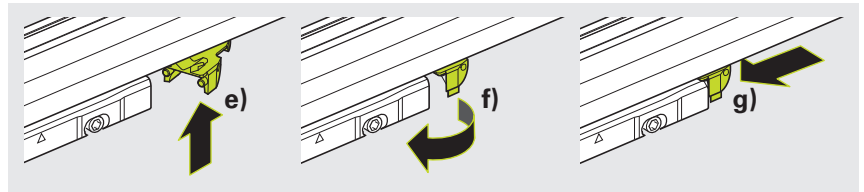

4.3 Choosing the mounting variant

Mounting with encoder end blocks

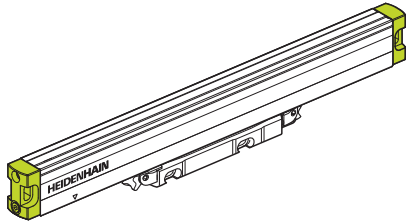

Mounting with a mounting spar
MSL 41 (separate accessory)

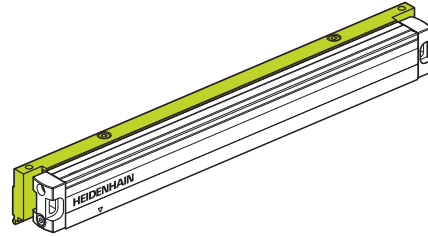

Page 20

Page 29

4.4 Mounting with end blocks



The mounting variants in this chapter refer to mounting by means of the encoder end blocks. HEIDENHAIN recommends mounting with the cable outlet on the right. This mounting option provides higher vibration resistance and an improved thermal connection of the scale unit to the machine base. The mounting variants with a mounting spar are described on **Page 30**.

Mounting by means of the encoder end blocks

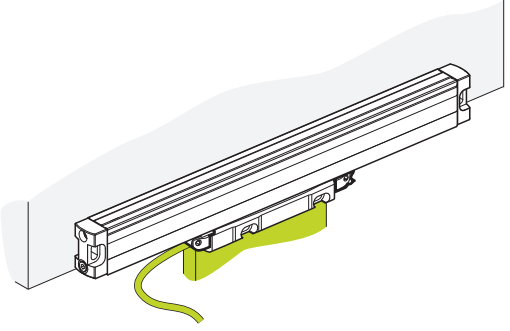
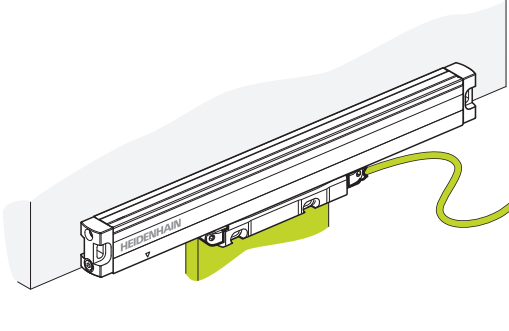
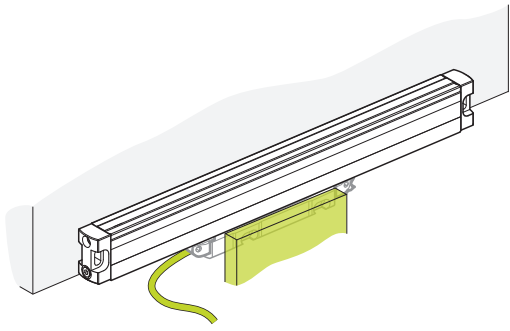
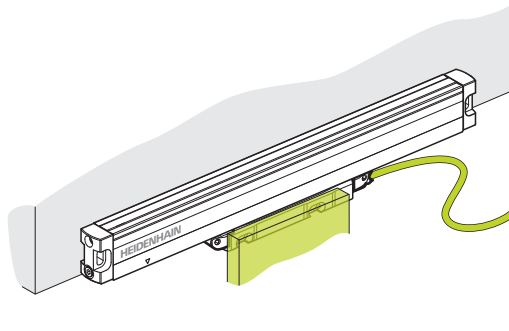
	Cable outlet on the left	Cable outlet on the right
Equal mounting surfaces	 <p>ELG variant Page 21</p>	 <p>ERG variant Page 23</p>
Opposite mounting surfaces	 <p>ELE variant Page 25</p>	 <p>ERE variant Page 27</p>

4.4.1 Variant: cable outlet on the left, equal mounting surfaces (ELG)

Materials and tools

For this task, the following materials and tools are needed:

Included in delivery

- Four tooth lock washers (D7.0/4.3)
- Clips (to be used optionally)

To be provided separately

- Four screws (ISO 4762 – M4)
- 3 mm hexagon socket tool
- Torque wrench (3 mm hexagon socket)
- Two screw nuts (ISO 4032 – M4, optional)

Mounting the scale unit

To mount the scale unit with the specified screws and tooth lock washers by means of the end blocks:

- ▶ Lightly tighten the screws
- ▶ Align the scale unit with the machine guideway (**F**) at the indicated positions
- ▶ Tighten the screws with the specified torque
- ▶ Check the alignment at the indicated positions (**L**) in the center or on the ridge

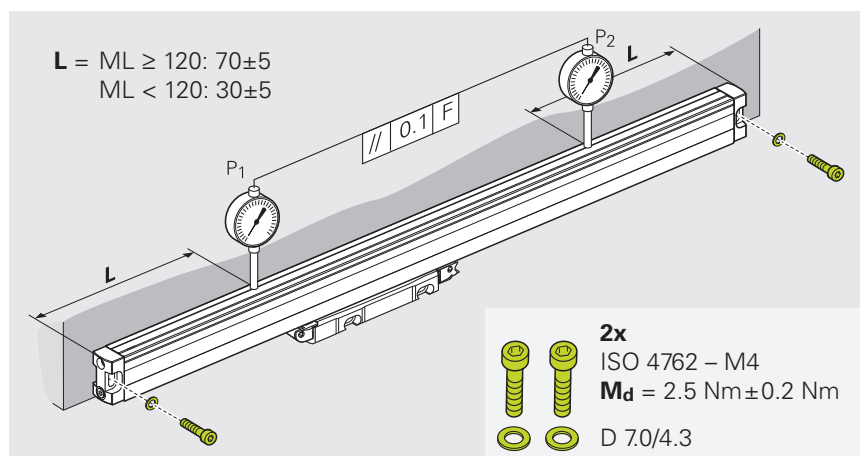

Mounting the scanning unit

i In order to set and check the gap between the scale unit and the scanning unit, you can either use the shipping brace or the mounting and check gauges that are available separately.

Further information: "Mounting accessories", Page 11

i To align the adjustable machine parts with the scanning unit, you can use the locked shipping brace.

Further information: "Function and handling of the shipping brace", Page 16

Requirements:

- The scale unit is mounted.
- The mounting tolerances (**K1**) and (**K2**) are already set on the machine.

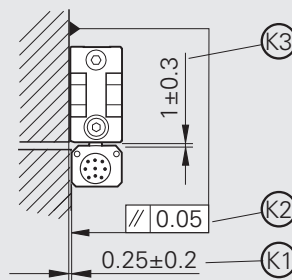

Mount the scanning unit with the specified materials:

- With screws and tooth lock washers or
- With screws, nuts and clips

Proceed as follows:

- ▶ Lightly tighten the screws
- ▶ Set the gap (**K3**) between the scanning unit and the scale unit
- ▶ Tighten the screws with the specified torque
- ▶ Check the gap (**K3**)

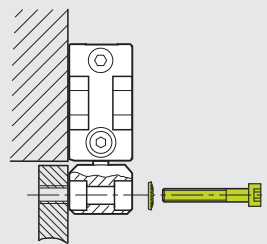

2x
ISO 4762 – M4
M_d = 2.5 Nm ± 0.2 Nm
D7.0/4.3

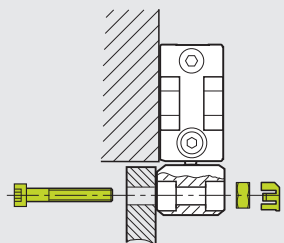

2x
ISO 4762 – M4
M_d = 2.5 Nm ± 0.2 Nm
ISO 4023 - M4
Clipse

Further information: "Final steps", Page 39

4.4.2 Variant: cable outlet on the right, equal mounting surfaces (ERG)

Materials and tools

For this task, the following materials and tools are needed:

Included in delivery

- Four tooth lock washers (D7.0/4.3)
- Clips (to be used optionally)

To be provided separately

- Four screws (ISO 4762 – M4)
- 3 mm hexagon socket tool
- Torque wrench (3 mm hexagon socket)
- Two screw nuts (ISO 4032 – M4, optional)

Mounting the scale unit

To mount the scale unit with the specified screws and tooth lock washers by means of the end blocks:

- ▶ Lightly tighten the screws
- ▶ Align the scale unit with the machine guideway (**F**) at the indicated positions
- ▶ Tighten the screws with the specified torque
- ▶ Check the alignment at the indicated positions (**L**) in the center or on the ridge

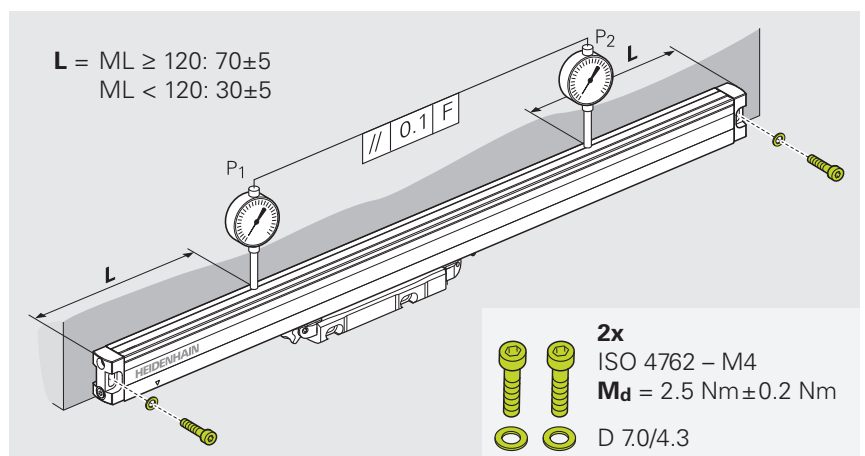

To increase the vibration resistance, you can additionally fix the scale unit with clamping elements (separate accessory).

Further information: "Mounting accessories", Page 11



For further information, refer to the **Mounting Instructions Clamping Element LC 400** document.

- ▶ www.heidenhain.com/documentation
- ▶ Enter the document ID **578067**

Mounting the scanning unit

i In order to set and check the gap between the scale unit and the scanning unit, you can either use the shipping brace or the mounting and check gauges that are available separately.

Further information: "Mounting accessories", Page 11

i To align the adjustable machine parts with the scanning unit, you can use the locked shipping brace.

Further information: "Function and handling of the shipping brace", Page 16

Requirements:

- The scale unit is mounted.
- The mounting tolerances (**K1**) and (**K2**) are already set on the machine.

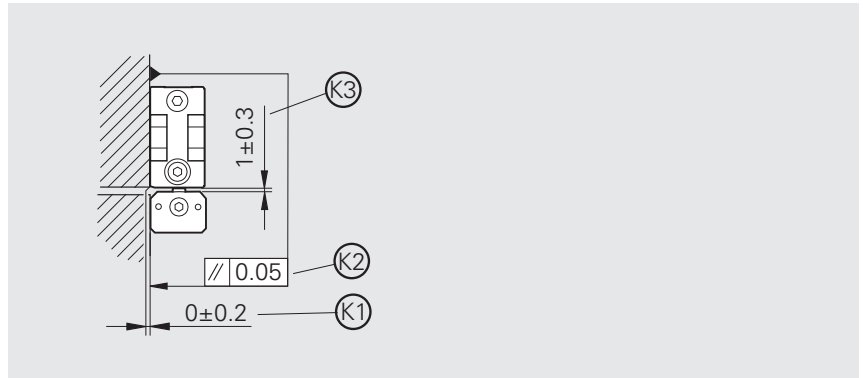

Mount the scanning unit with the specified materials:

- With screws and tooth lock washers or
- With screws, nuts and clips

Proceed as follows:

- ▶ Lightly tighten the screws
- ▶ Set the gap (**K3**) between the scanning unit and the scale unit
- ▶ Tighten the screws with the specified torque
- ▶ Check the gap (**K3**)

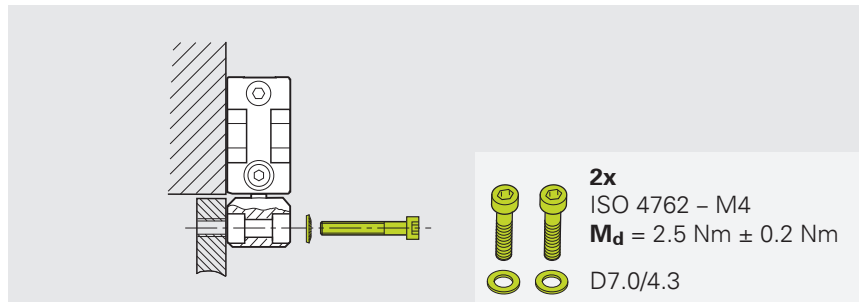

2x
ISO 4762 – M4
M_d = 2.5 Nm ± 0.2 Nm
D7.0/4.3

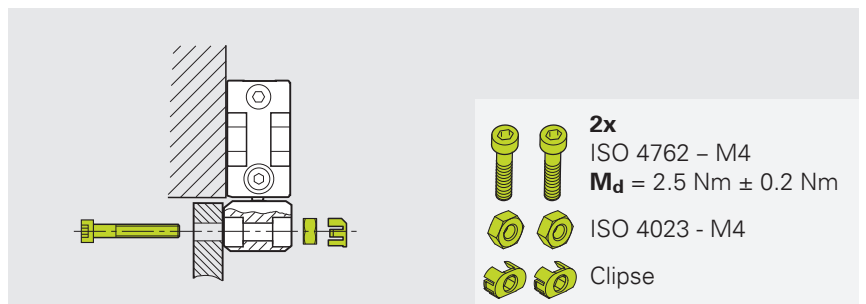

2x
ISO 4762 – M4
M_d = 2.5 Nm ± 0.2 Nm
ISO 4023 - M4
Clipse

Further information: "Final steps", Page 39

4.4.3 Variant: cable outlet on the left, opposite mounting surfaces (ELE)

Materials and tools

For this task, the following materials and tools are needed:

Included in delivery

- Four tooth lock washers (D7.0/4.3)
- Clips (to be used optionally)

To be provided separately

- Four screws (ISO 4762 – M4)
- 3 mm hexagon socket tool
- Torque wrench (3 mm hexagon socket)
- Two screw nuts (ISO 4032 – M4, optional)

Mounting the scale unit

To mount the scale unit with the specified screws and tooth lock washers by means of the end blocks:

- ▶ Lightly tighten the screws
- ▶ Align the scale unit with the machine guideway (**F**) at the indicated positions
- ▶ Tighten the screws with the specified torque
- ▶ Check the alignment at the indicated positions (**L**) in the center or on the ridge

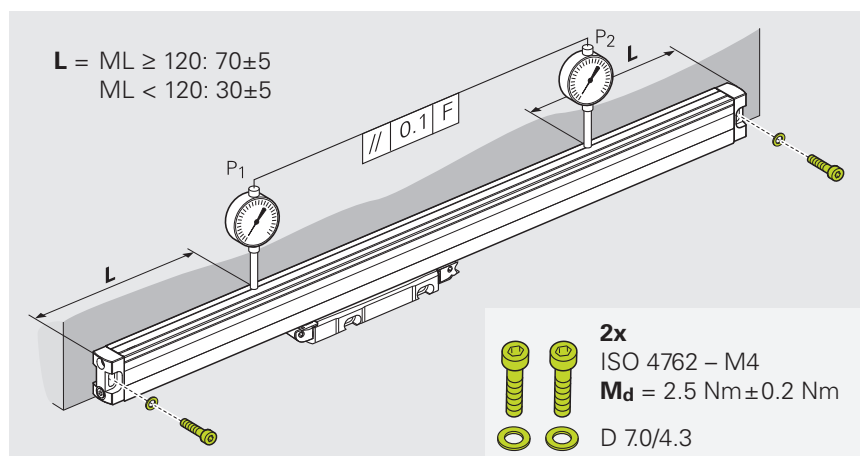

Mounting the scanning unit

i In order to set and check the gap between the scale unit and the scanning unit, you can either use the shipping brace or the mounting and check gauges that are available separately.

Further information: "Mounting accessories", Page 11

i To align the adjustable machine parts with the scanning unit, you can use the locked shipping brace.

Further information: "Function and handling of the shipping brace", Page 16

Requirements:

- The scale unit is mounted.
- The mounting tolerances (**K1**) and (**K2**) are already set on the machine.

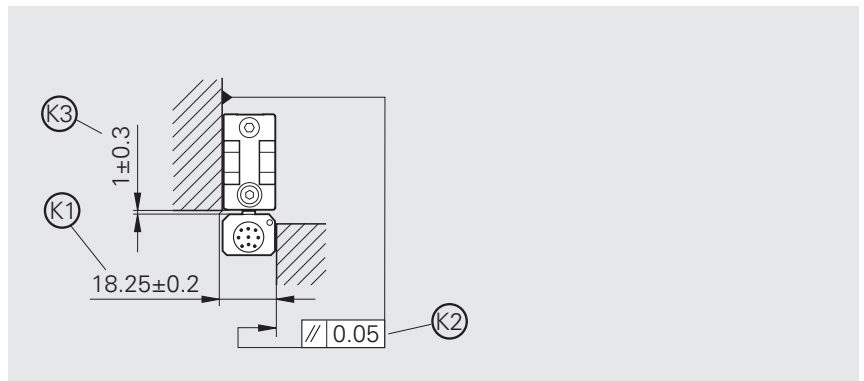

Mount the scanning unit with the specified materials:

- With screws and tooth lock washers or
- With screws, nuts and clips

Proceed as follows:

- ▶ Lightly tighten the screws
- ▶ Set the gap (**K3**) between the scanning unit and the scale unit
- ▶ Tighten the screws with the specified torque
- ▶ Check the gap (**K3**)

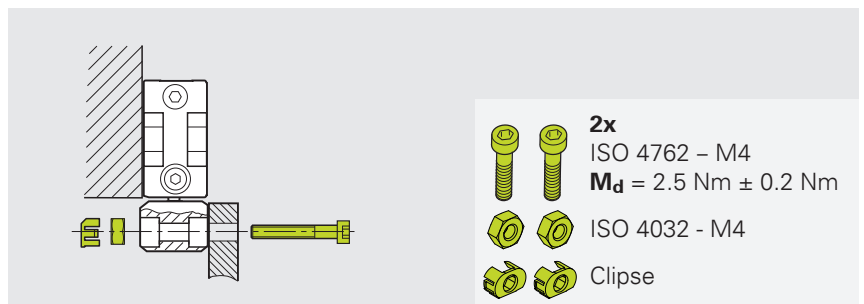
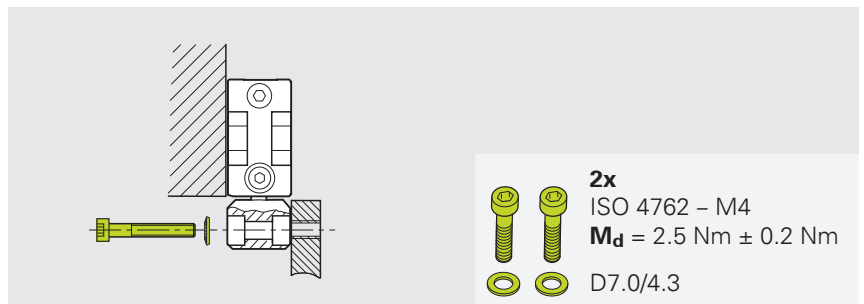

Further information: "Final steps", Page 39

4.4.4 Variant: cable outlet on the right, opposite mounting surfaces (ERE)

Materials and tools

For this task, the following materials and tools are needed:

Included in delivery

- Four tooth lock washers (D7.0/4.3)
- Clips (to be used optionally)

To be provided separately

- Four screws (ISO 4762 – M4)
- 3 mm hexagon socket tool
- Torque wrench (3 mm hexagon socket)
- Two screw nuts (ISO 4032 – M4, optional)

Mounting the scale unit

To mount the scale unit with the specified screws and tooth lock washers by means of the end blocks:

- ▶ Lightly tighten the screws
- ▶ Align the scale unit with the machine guideway (**F**) at the indicated positions
- ▶ Tighten the screws with the specified torque
- ▶ Check the alignment at the indicated positions (**L**) in the center or on the ridge

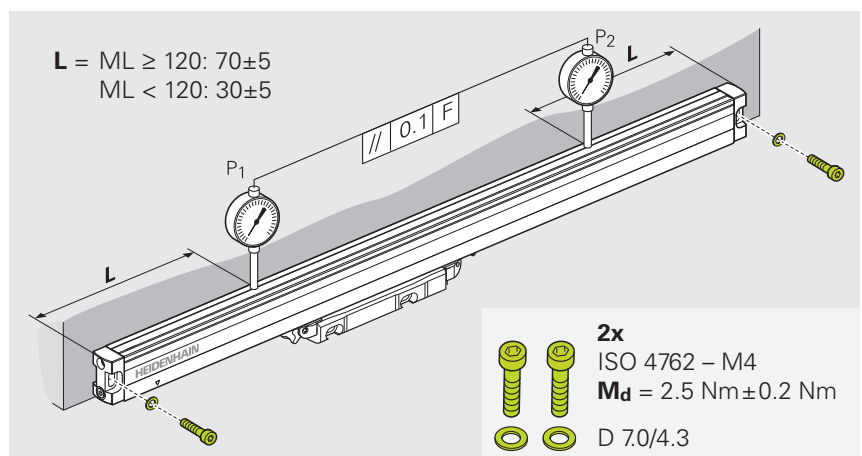

To increase the vibration resistance, you can additionally fix the scale unit with clamping elements (separate accessory).

Further information: "Mounting accessories", Page 11



For further information, refer to the **Mounting Instructions Clamping Element LC 400** document.

- ▶ www.heidenhain.com/documentation
- ▶ Enter the document ID **578067**

Mounting the scanning unit

i In order to set and check the gap between the scale unit and the scanning unit, you can either use the shipping brace or the mounting and check gauges that are available separately.

Further information: "Mounting accessories", Page 11

i To align the adjustable machine parts with the scanning unit, you can use the locked shipping brace.

Further information: "Function and handling of the shipping brace", Page 16

Requirements:

- The scale unit is mounted.
- The mounting tolerances (**K1**) and (**K2**) are already set on the machine.

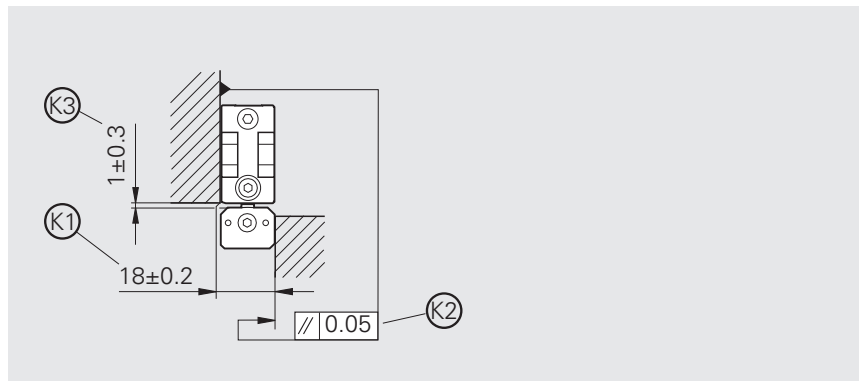

Mount the scanning unit with the specified materials:

- With screws and tooth lock washers or
- With screws, nuts and clips

Proceed as follows:

- ▶ Lightly tighten the screws
- ▶ Set the gap (**K3**) between the scanning unit and the scale unit
- ▶ Tighten the screws with the specified torque
- ▶ Check the gap (**K3**)

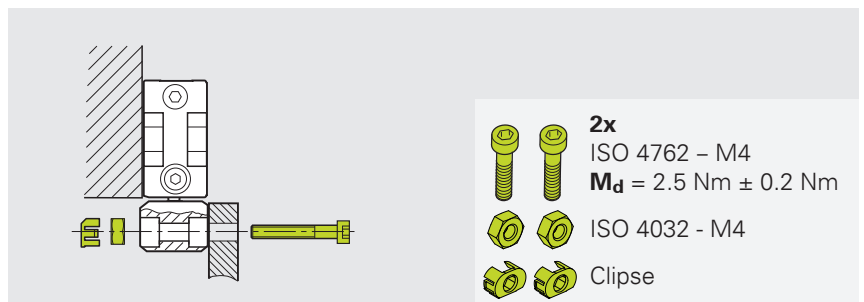
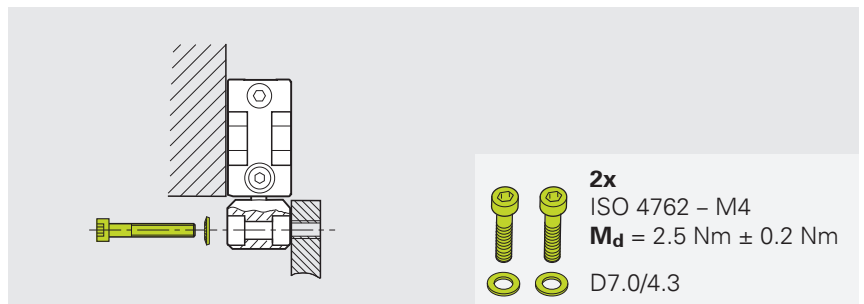

Further information: "Final steps", Page 39

4.5 Mounting with mounting spar



The mounting variants in this chapter refer to mounting of the device with a mounting spar. HEIDENHAIN recommends mounting with the cable outlet on the right. This mounting option provides a higher vibration resistance. The mounting variants without a mounting spar (mounting by means of the end blocks) are described on **Page 20**.

4.5.1 Mounting the mounting spar

Materials and tools

For this mounting variant, the following materials and tools are needed:

Included in delivery

- Washers

To be provided separately

- Screws (ISO 4762 – M6x10 or M5x10) screws
- 5 mm or 4 mm Allen key
- Torque wrench (hexagon socket, 5 mm or 4 mm)

Mounting the mounting spar

To mount the mounting spar with the specified screws and washers:

- ▶ Lightly tighten the screws
- ▶ Align the mounting spar with the guideway **(F)** at the indicated positions
- ▶ Tighten the screws with the specified torque
- ▶ Check the alignment at the indicated positions

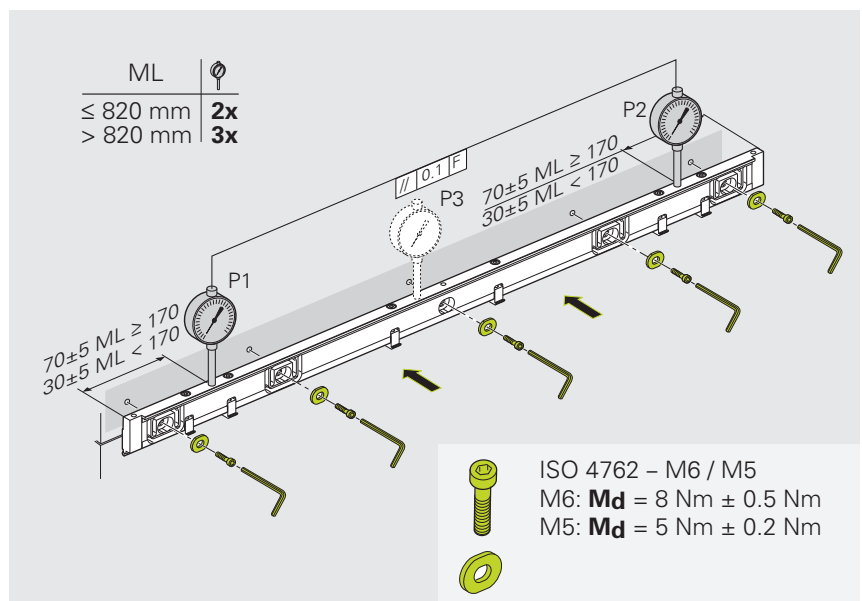

Mounting variants

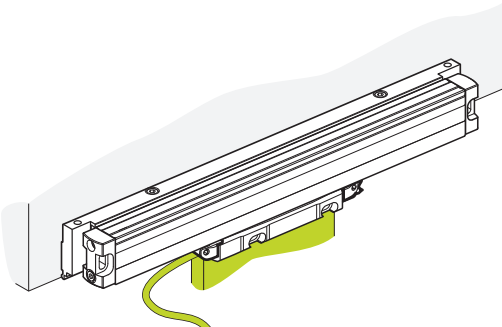
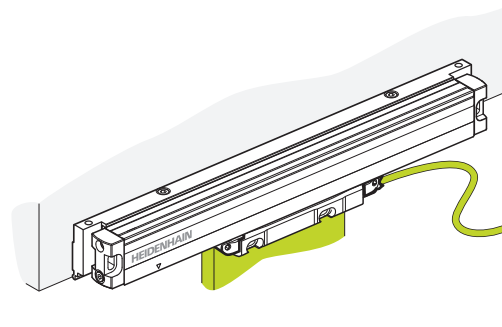
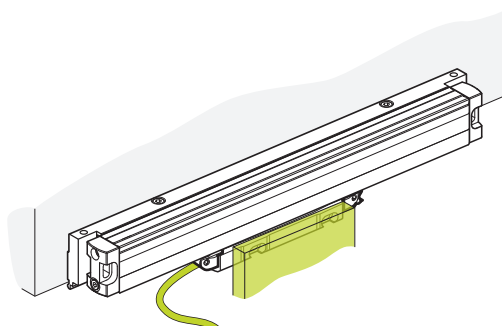
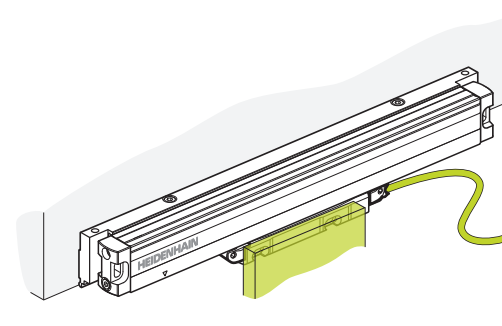
		Mounting with mounting spar	
		Cable outlet on the left	Cable outlet on the right
Equal mounting surfaces		MLG variant	Page 31
		MRG variant	Page 33
Opposite mounting surfaces		MLE variant	Page 35
		MRE variant	Page 37

4.5.2 Variant: cable outlet on the left, equal mounting surfaces (MLG)

Requirement: The mounting spar is attached to the mounting surface.

Materials and tools

For this mounting variant, the following materials and tools are needed:

Included in delivery

- Two tooth lock washers (D7.0/4.3)
- Clips (to be used optionally)

To be provided separately

- Two screws (ISO 4762 – M4)
- 3 mm hexagon socket tool (or Torx T 8)
- Torque wrench (hexagon socket, 3 mm or Torx T 8)
- Two screw nuts (ISO 4032 – M4, optional)

Mounting the scale unit

- ▶ Place the scale unit in the mounting spar

i Make sure that the lower edge engages first.

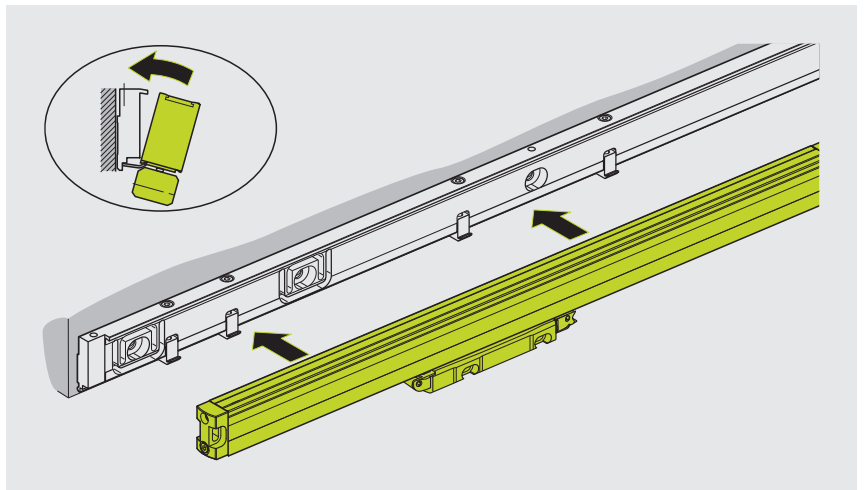

- ▶ Align the scale unit

i Pay attention to the lateral distances to the mounting spar.

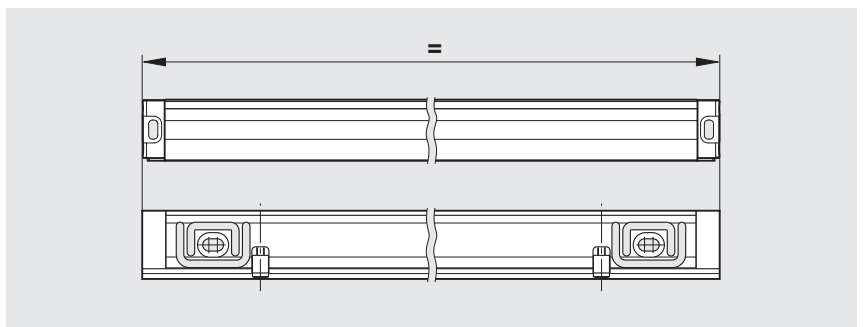

- ▶ Tighten the screws in the specified order with the specified torque

i Use the specified tool depending on whether you tighten the screws from above or from below.

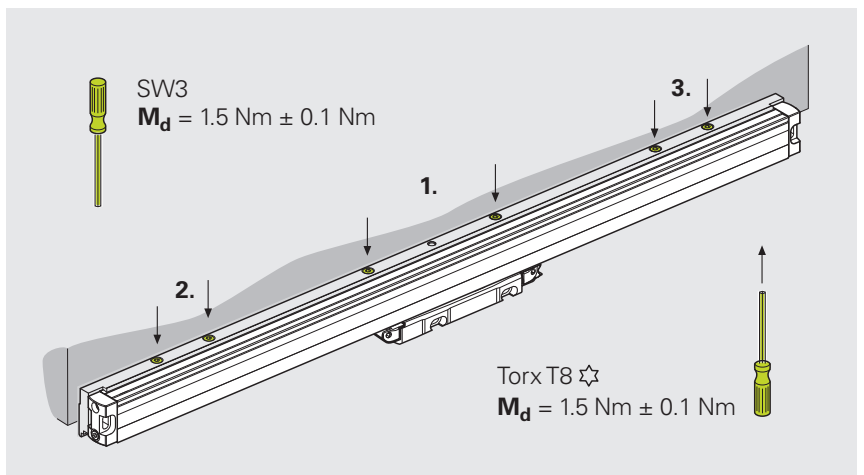

Mounting the scanning unit

i In order to set and check the gap between the scale unit and the scanning unit, you can either use the shipping brace or the mounting and check gauges that are available separately.

Further information: "Mounting accessories", Page 11

i You can use the following aids to align the adjustable machine parts with the scanning unit:

- Locked shipping brace

Further information: "Function and handling of the shipping brace", Page 16

- Mounting aid ID 753853-01

Further information: "For mounting with a mounting spar", Page 11

Requirements:

- The scale unit is mounted.
- The mounting tolerances (**K1**) and (**K2**) are already set on the machine.

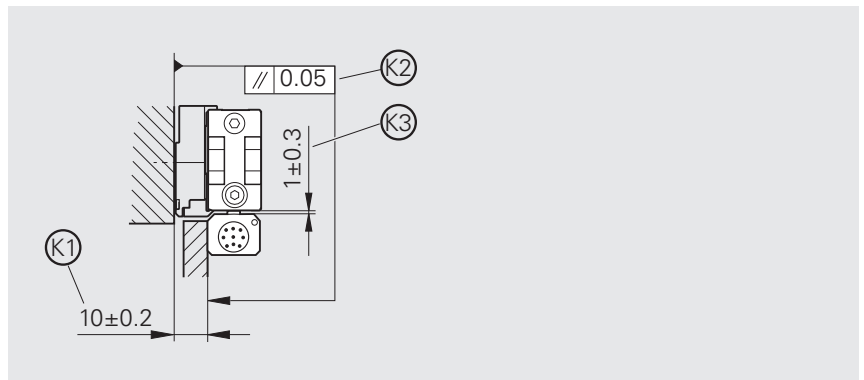

Mount the scanning unit with the specified materials:

- With screws and tooth lock washers or
- With screws, nuts and clips

Proceed as follows:

- ▶ Lightly tighten the screws
- ▶ Set the gap (**K3**) between the scanning unit and the scale unit
- ▶ Tighten the screws with the specified torque
- ▶ Check the gap (**K3**)

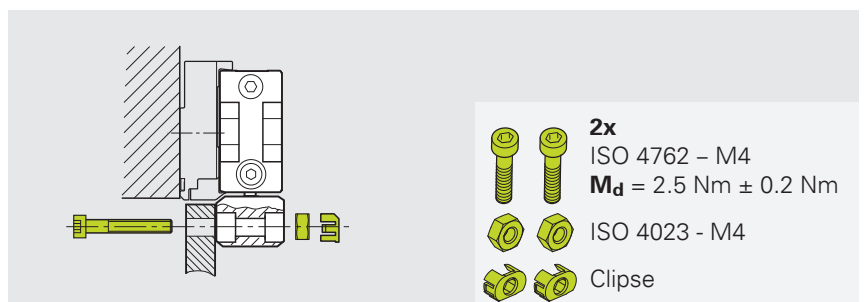
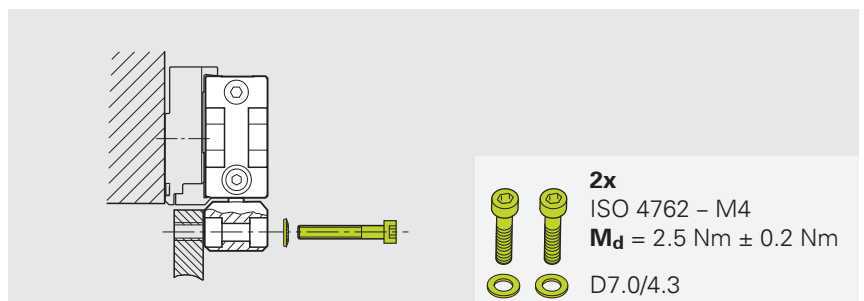

Further information: "Final steps", Page 39

4.5.3 Variant: cable outlet on the right, equal mounting surfaces (MRG)

Requirement: The mounting spar is attached to the mounting surface.

Materials and tools

For this mounting variant, the following materials and tools are needed:

Included in delivery

- Two tooth lock washers (D7.0/4.3)
- Clips (to be used optionally)

To be provided separately

- Two screws (ISO 4762 – M4)
- 3 mm hexagon socket tool (or Torx T 8)
- Torque wrench (hexagon socket, 3 mm or Torx T 8)
- Two screw nuts (ISO 4032 – M4, optional)

Mounting the scale unit

- ▶ Place the scale unit in the mounting spar

i Make sure that the lower edge engages first.

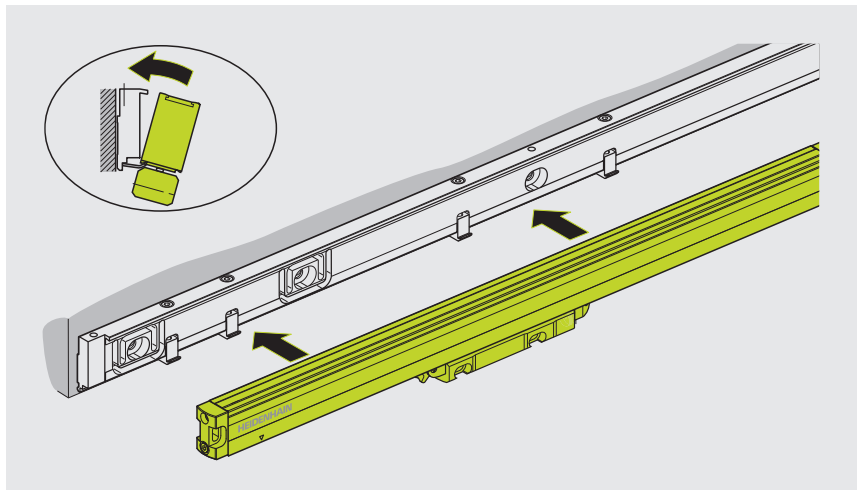

- ▶ Align the scale unit

i Pay attention to the lateral distances to the mounting spar.

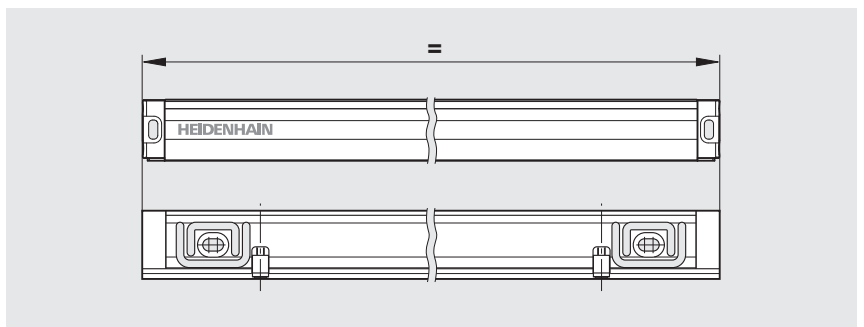

- ▶ Tighten the screws in the specified order with the specified torque

i Use the specified tool depending on whether you tighten the screws from above or from below.

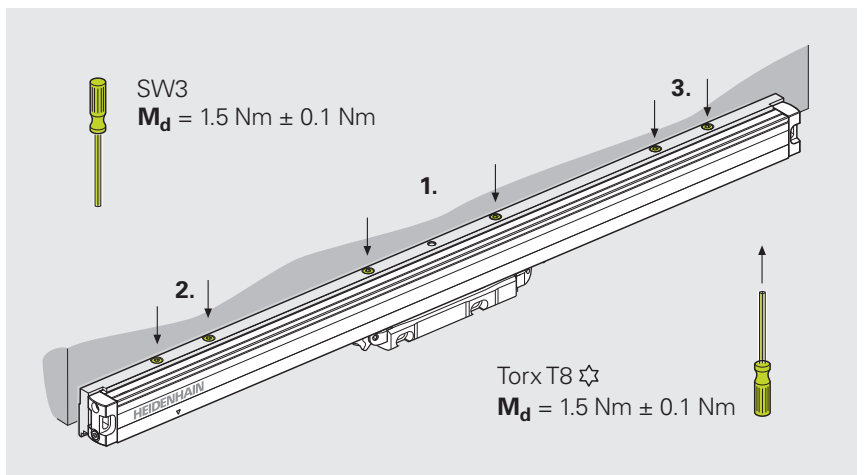

Mounting the scanning unit

i In order to set and check the gap between the scale unit and the scanning unit, you can either use the shipping brace or the mounting and check gauges that are available separately.

Further information: "Mounting accessories", Page 11

i You can use the following aids to align the adjustable machine parts with the scanning unit:

- Locked shipping brace

Further information: "Function and handling of the shipping brace", Page 16

- Mounting aid ID 753853-01

Further information: "For mounting with a mounting spar", Page 11

Requirements:

- The scale unit is mounted.
- The mounting tolerances (**K1**) and (**K2**) are already set on the machine.

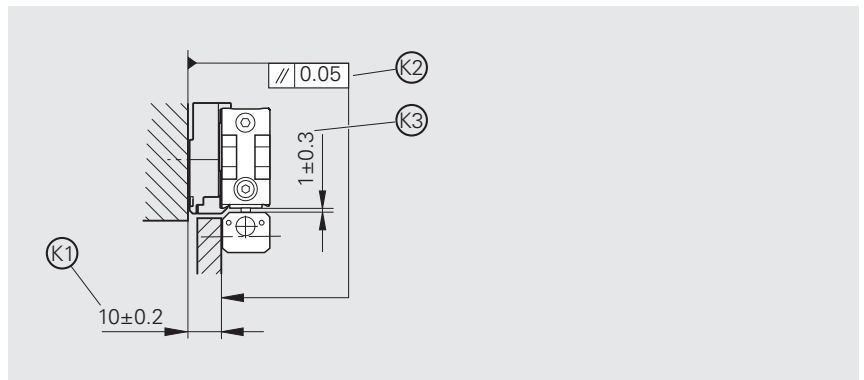

Mount the scanning unit with the specified materials:

- With screws and tooth lock washers or
- With screws, nuts and clips

Proceed as follows:

- ▶ Lightly tighten the screws
- ▶ Set the gap (**K3**) between the scanning unit and the scale unit
- ▶ Tighten the screws with the specified torque
- ▶ Check the gap (**K3**)

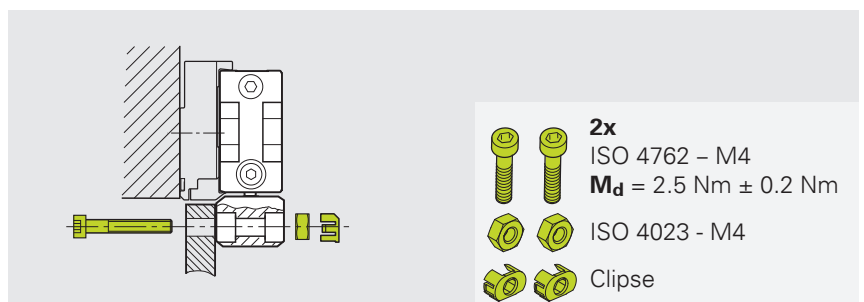
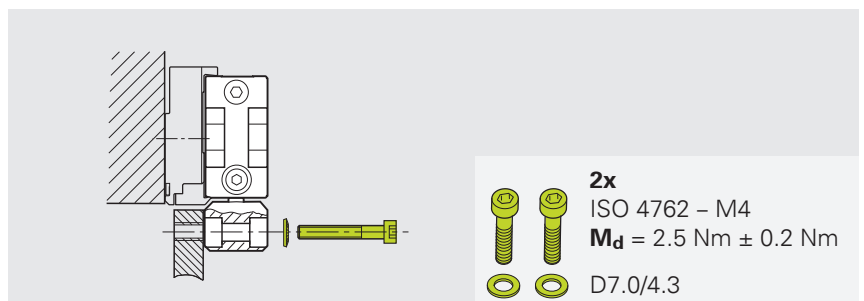

Further information: "Final steps", Page 39

4.5.4 Variant: cable outlet on the left, opposite mounting surfaces (MLE)

Requirement: The mounting spar is attached to the mounting surface.

Materials and tools

For this mounting variant, the following materials and tools are needed:

Included in delivery

- Two tooth lock washers (D7.0/4.3)
- Clips (to be used optionally)

To be provided separately

- Two screws (ISO 4762 – M4)
- 3 mm hexagon socket tool (or Torx T 8)
- Torque wrench (hexagon socket, 3 mm or Torx T 8)
- Two screw nuts (ISO 4032 – M4, optional)

Mounting the scale unit

- ▶ Place the scale unit in the mounting spar

i Make sure that the lower edge engages first.

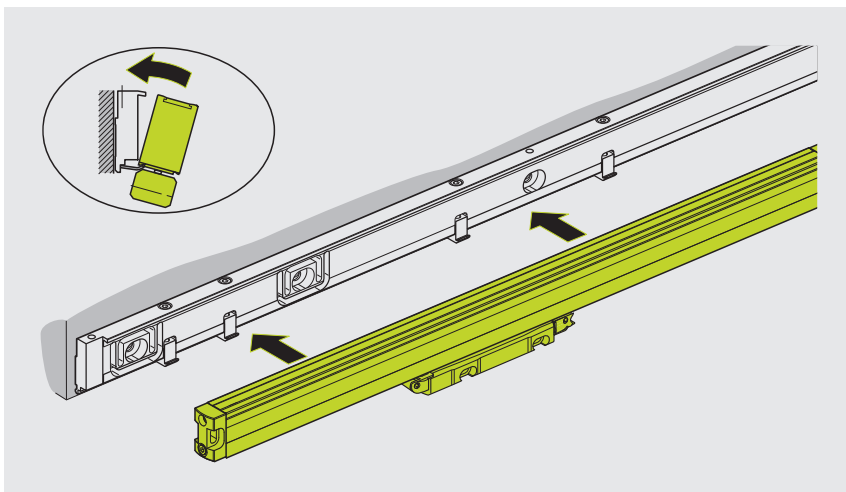

- ▶ Align the scale unit

i Pay attention to the lateral distances to the mounting spar.

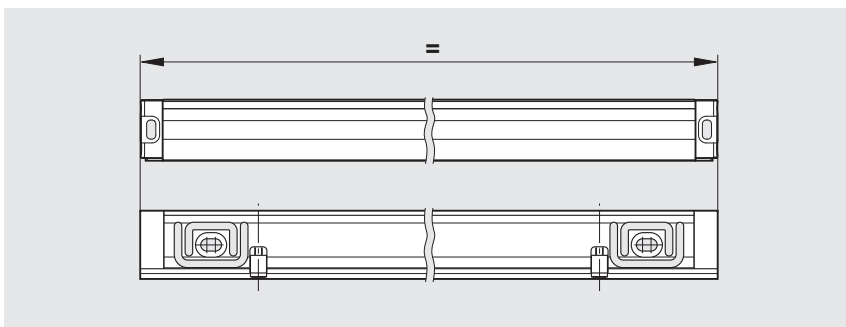

- ▶ Tighten the screws in the specified order with the specified torque

i Use the specified tool depending on whether you tighten the screws from above or from below.

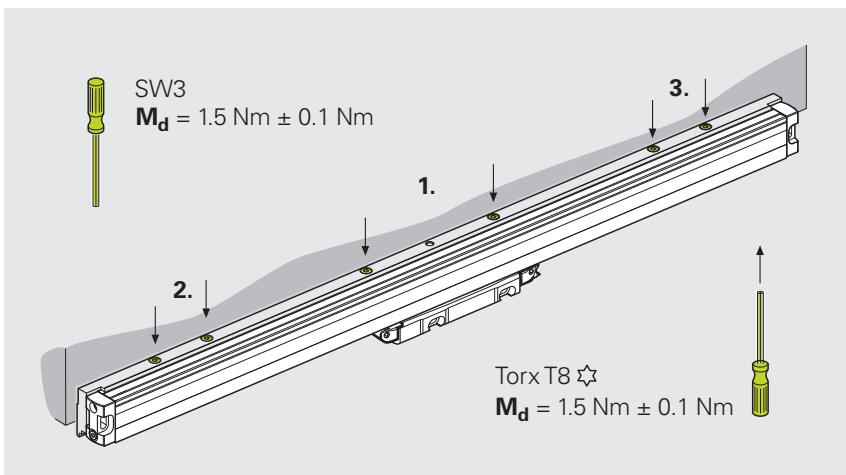

Mounting the scanning unit

i In order to set and check the gap between the scale unit and the scanning unit, you can either use the shipping brace or the mounting and check gauges that are available separately.

Further information: "Mounting accessories", Page 11

i You can use the following aids to align the adjustable machine parts with the scanning unit:

- Locked shipping brace

Further information: "Function and handling of the shipping brace", Page 16

- Mounting aid ID 753853-01

Further information: "For mounting with a mounting spar", Page 11

Requirements:

- The scale unit is mounted.
- The mounting tolerances (**K1**) and (**K2**) are already set on the machine.

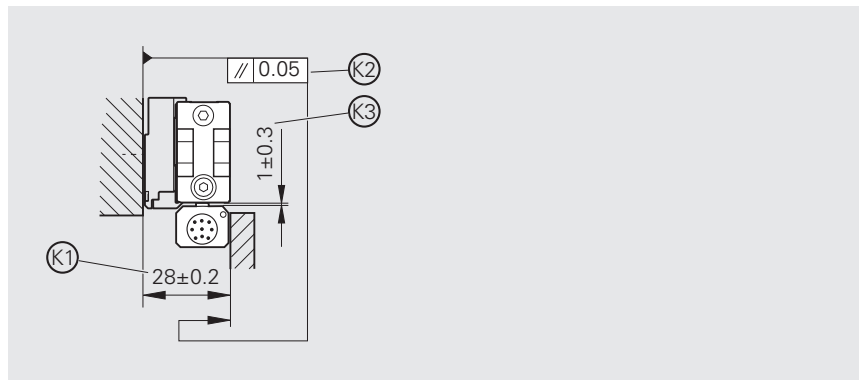

Mount the scanning unit with the specified materials:

- With screws and tooth lock washers or
- With screws, nuts and clips

Proceed as follows:

- ▶ Lightly tighten the screws
- ▶ Set the gap (**K3**) between the scanning unit and the scale unit
- ▶ Tighten the screws with the specified torque
- ▶ Check the gap (**K3**)

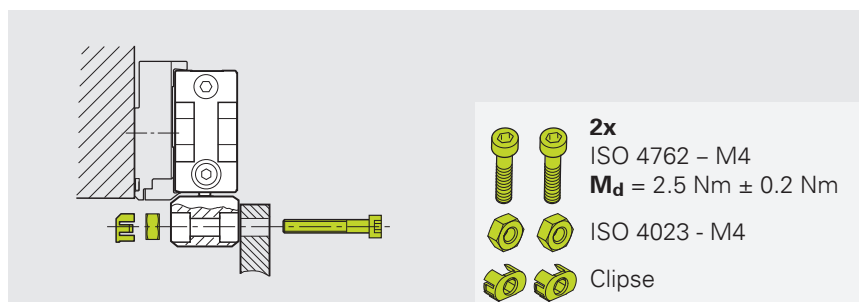
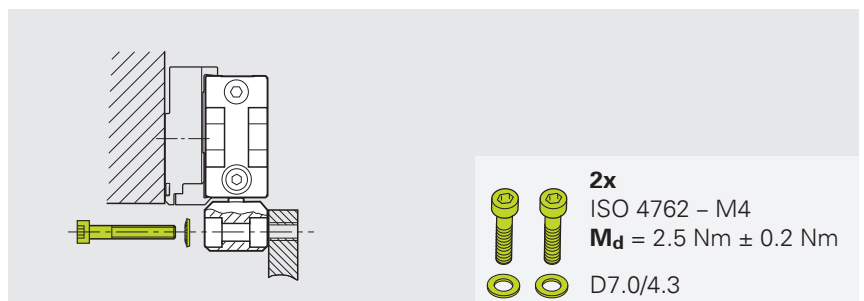

Further information: "Final steps", Page 39

4.5.5 Variant: cable outlet on the right, opposite mounting surfaces (MRE)

Requirement: The mounting spar is attached to the mounting surface.

Materials and tools

For this mounting variant, the following materials and tools are needed:

Included in delivery

- Two tooth lock washers (D7.0/4.3)
- Clips (to be used optionally)

To be provided separately

- Two screws (ISO 4762 – M4)
- 3 mm hexagon socket tool (or Torx T 8)
- Torque wrench (hexagon socket, 3 mm or Torx T 8)
- Two screw nuts (ISO 4032 – M4, optional)

Mounting the scale unit

- ▶ Place the scale unit in the mounting spar

i Make sure that the lower edge engages first.

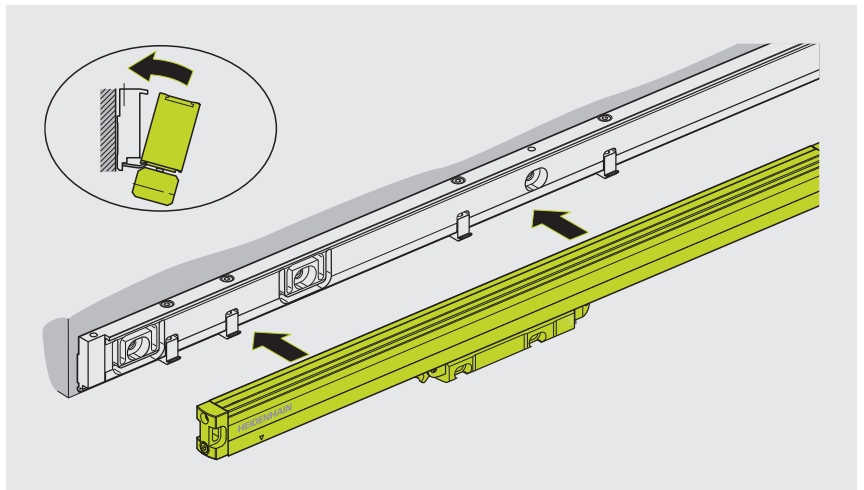

- ▶ Align the scale unit

i Pay attention to the lateral distances to the mounting spar.

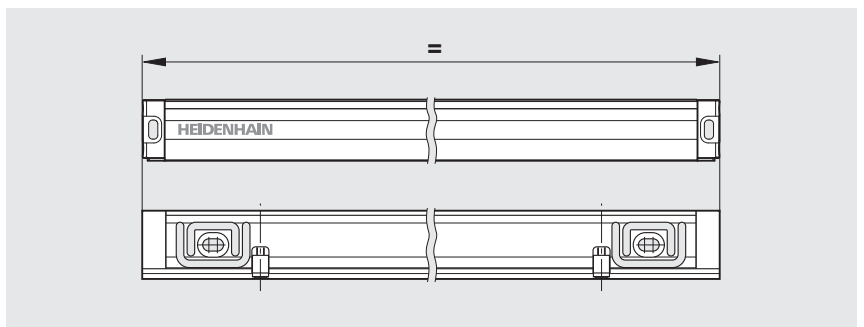

- ▶ Tighten the screws in the specified order with the specified torque

i Use the specified tool depending on whether you tighten the screws from above or from below.

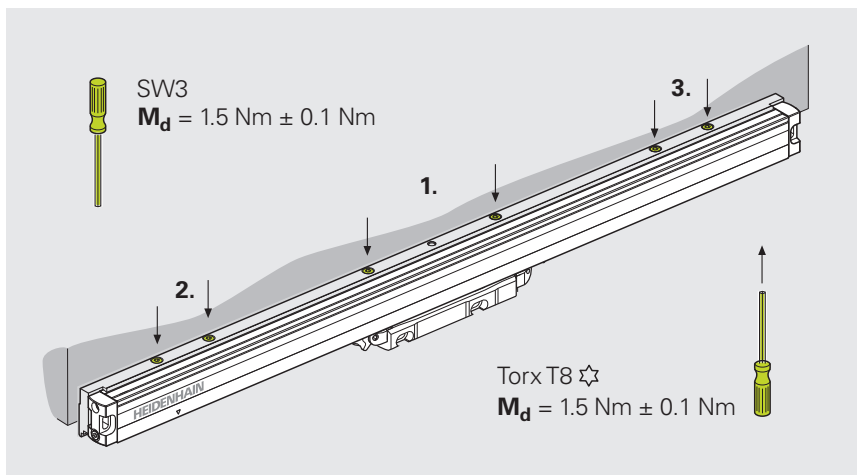

Mounting the scanning unit

i In order to set and check the gap between the scale unit and the scanning unit, you can either use the shipping brace or the mounting and check gauges that are available separately.

Further information: "Mounting accessories", Page 11

i You can use the following aids to align the adjustable machine parts with the scanning unit:

- Locked shipping brace

Further information: "Function and handling of the shipping brace", Page 16

- Mounting aid ID 753853-01

Further information: "For mounting with a mounting spar", Page 11

Requirements:

- The scale unit is mounted.
- The mounting tolerances (**K1**) and (**K2**) are already set on the machine.

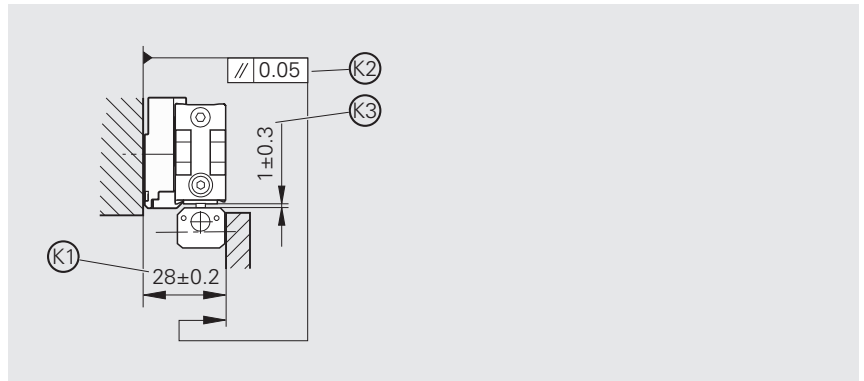

Mount the scanning unit with the specified materials:

- With screws and tooth lock washers or
- With screws, nuts and clips

Proceed as follows:

- ▶ Lightly tighten the screws
- ▶ Set the gap (**K3**) between the scanning unit and the scale unit
- ▶ Tighten the screws with the specified torque
- ▶ Check the gap (**K3**)

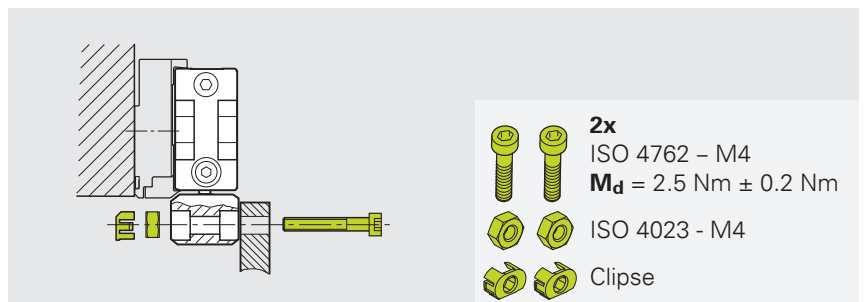
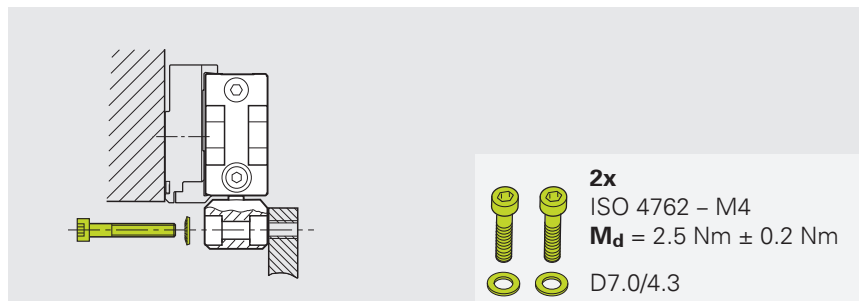

Further information: "Final steps", Page 39

5 Final steps

5.1 Continuity check

5.1.1 Requirements and notes

- i** For trouble-free operation, you need to ensure proper electrical coupling of the scanning unit and scale unit.
- ▶ Check the electrical connection

5.1.2 Materials and tools

For this mounting step, the following materials and tools are needed:

Included in delivery

To be provided separately

- Resistance measuring device

5.1.3 Resistance measurement

- ▶ Check the electrical resistance between the scale housing and the connector housing

i The electrical resistance between the scale housing and the connector housing must be $< 1 \Omega$.

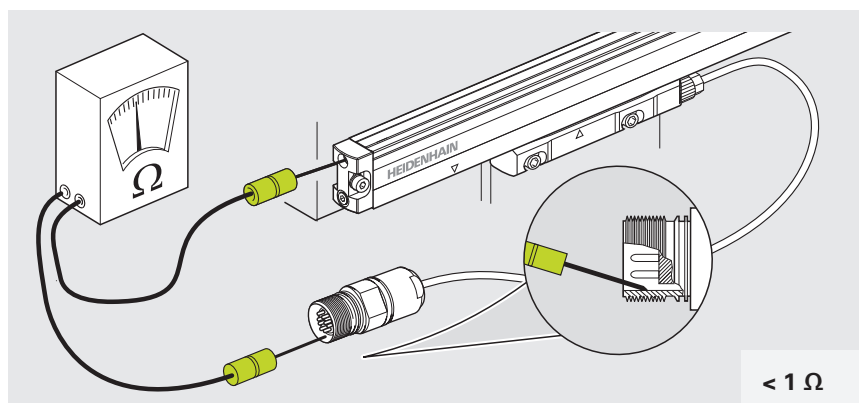

- ▶ Optionally connect the mounting spar with protective ground

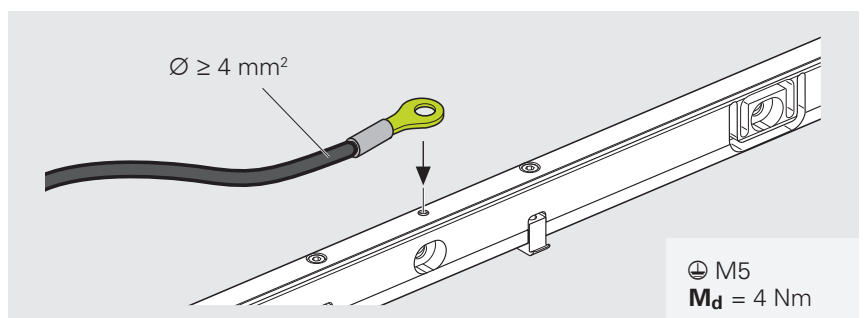

5.2 Using sealing air (optional)

5.2.1 Requirements and notes

i In many cases, the encoder can be operated without the use of sealing air. This is not possible, however, if the encoder is directly exposed to cooling lubricant and/or contamination with particles and dust. The applied compressed air must fulfill the requirements of quality classes 3/4/2 as per ISO 8573-1 (2010). For an optimal supply of sealing air, the required air flow is 7 l/min per encoder.

i The encoder has integrated throttles in the connection holes. The throttles ensure the required flow quantity of 7 l/min at an input pressure of $1 \cdot 10^5$ Pa (1 bar). You can use standard M5 threaded plug connections without throttle as well as HEIDENHAIN connecting pieces with integrated throttle to connect the pressure tubing.

Further information: "Accessories for connecting the sealing-air supply", Page 12

For vertical mounting of the encoder and connection to the scale unit, use only the connection at the top. This will protect the scale unit from contamination.

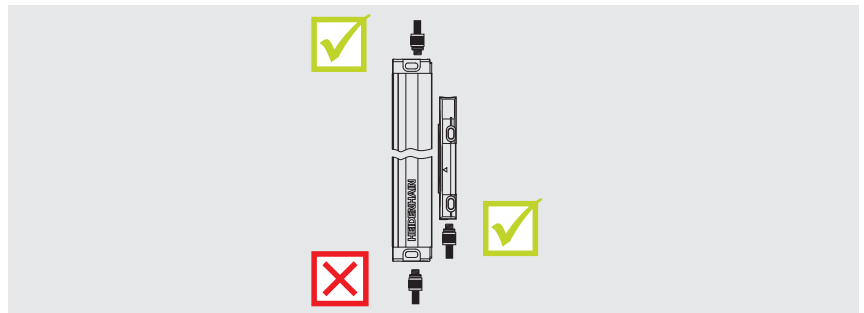

5.2.2 Materials and tools

To connect compressed air, the following materials and tools are needed:

Included in delivery

To be provided separately

- Mounting tool depending on the connecting pieces used
- Connecting pieces

5.2.3 Connecting compressed air to the encoder

Depending on the machine-specific requirements, the following mounting variants are possible:

- Compressed air inlet on scale unit or
- Compressed air inlet on scanning unit

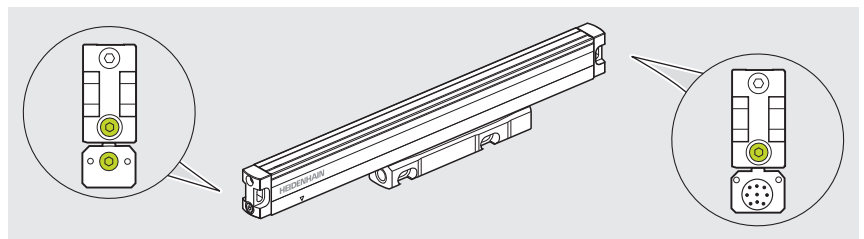

- ▶ Remove the stop plug from the selected inlet
- ▶ Screw in the connecting piece at the desired position
- ▶ Tighten the connecting piece with the specified torque
- ▶ Connect the compressed air inlet to the filter system

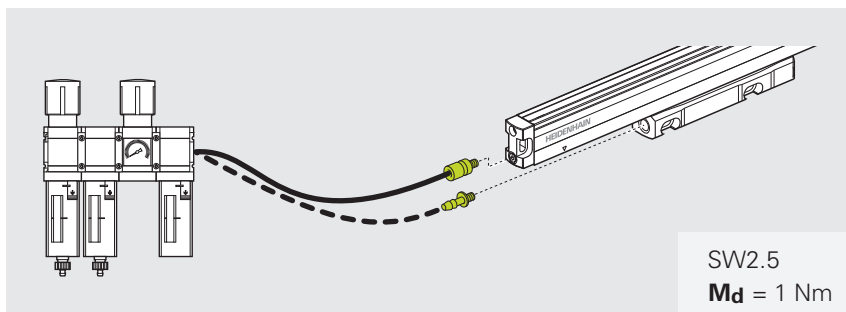

5.3 Connecting the cable

5.3.1 Prerequisites and notes

i The protective cap of the pre-assembled cable can be used as an aid.

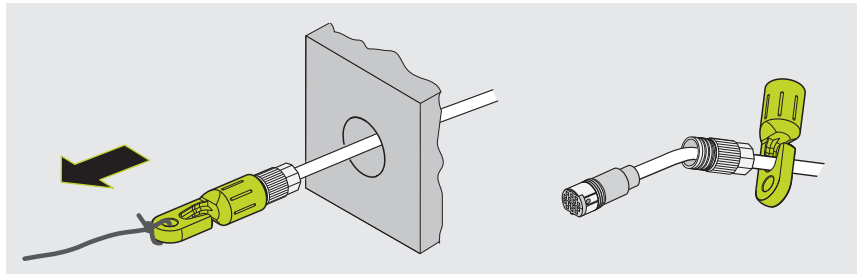

i Before you connect the pre-assembled cable, you need to remove the shipping brace on the cable side. After you have connected the pre-assembled cable, you can mount the shipping brace again.

Further information: "Mounting the shipping brace", Page 17

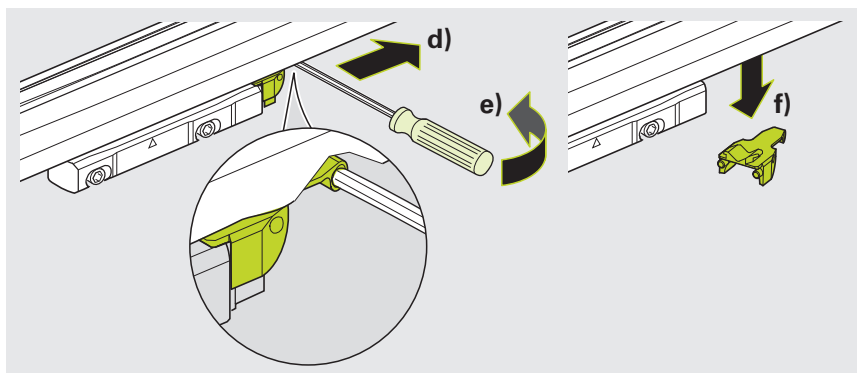

Maximum permissible bending radii

Keep in mind the maximum permissible bend radii when routing the cable.

	Ø 4.5 mm	Ø 6 mm Ø 6.8 mm	Ø 10 mm
<p>$T \geq -40\text{ °C}$ (-40 °F)</p>	$R_1 \geq 10\text{ mm}$	$R_1 \geq 20\text{ mm}$	$R_1 \geq 35\text{ mm}$
<p>$T \geq -10\text{ °C}$ (14 °F)</p>	$R_2 \geq 50\text{ mm}$	$R_2 \geq 75\text{ mm}$	$R_2 \geq 75\text{ mm}$

M For more information on the cable characteristics and cable routing, refer to the **Cables and Connectors** brochure.

- ▶ www.heidenhain.com/documentation
- ▶ Enter the document ID **1206103**

5.3.2 Materials and tools

For this task, the following materials and tools are needed:

Included in delivery

To be provided separately

- Wrench, AF 10
- Low-strength threadlocker
- Torque wrench and socket wrench (see "Accessories", Page 12)

5.3.3 Connecting the adapter cable to the encoder

- ▶ Remove the plastic cap

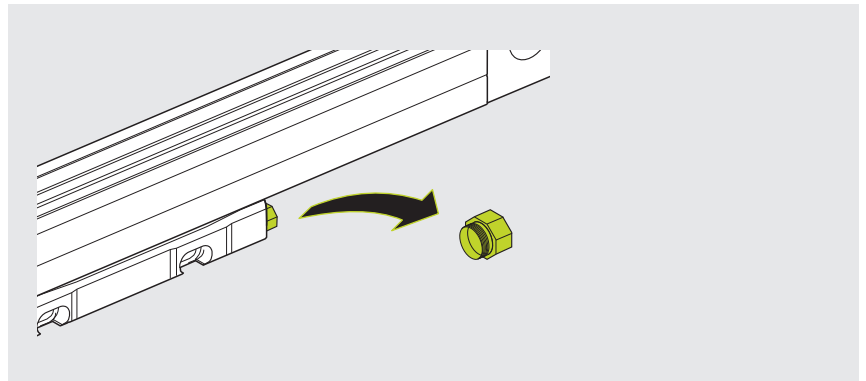

- ▶ Connect the cable to the mating socket of the encoder

i Pay attention to the correct alignment of the connector.

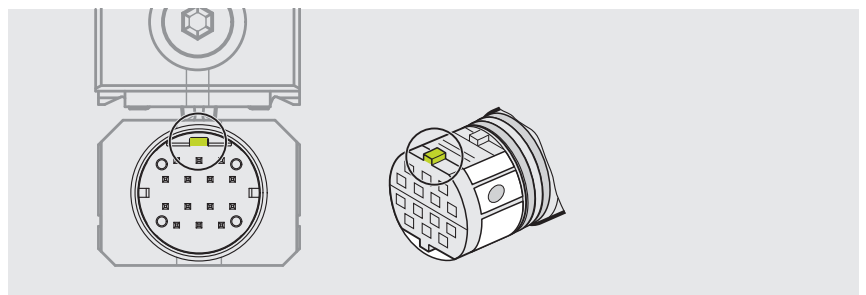
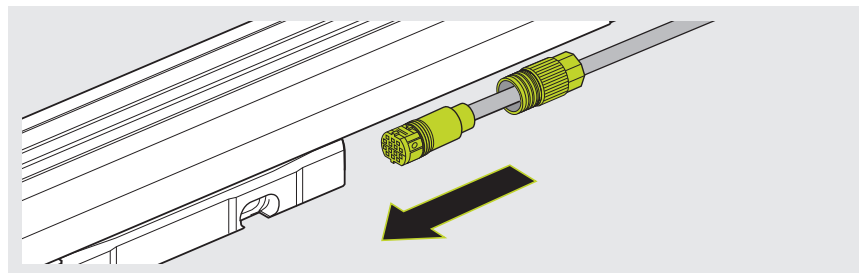

- ▶ Apply low-strength threadlocker to the coupling ring

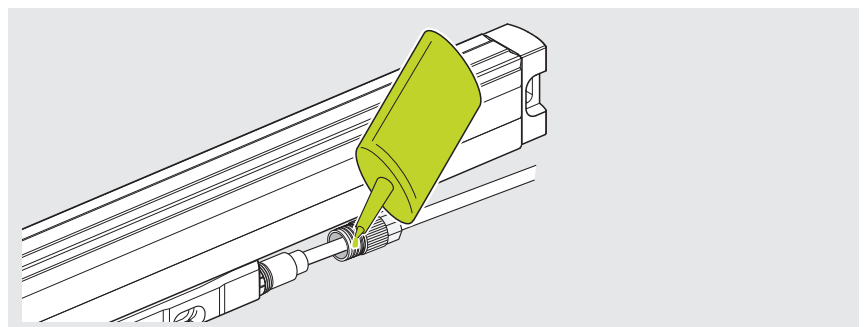

- ▶ Tighten the coupling ring with the specified torque

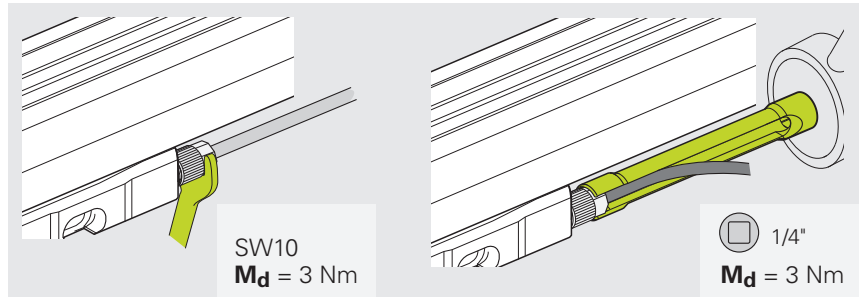

6 Removal

This chapter describes the removal of the product.

6.1 Safety precautions regarding removal

WARNING

Live plug connections!

If you disengage plug connections while the equipment is under power, this may result in fatal accidents or severe personal injury.

- ▶ Do not engage or disengage any connecting elements while the product is under power

WARNING

Moving machine parts!

Risk of injury due to moving machine parts depending on the installation location and the application

- ▶ Observe all of the machine manufacturer's notes on working on the machine, e.g., always disconnect the machine from the power supply

6.2 Removing the encoder

To remove the encoder, follow the mounting steps in the reverse order:

- ▶ Disconnect the cable connections on the encoder, Page 42
- ▶ Disconnect any air connections on the encoder, Page 40
- ▶ Depending on the mounting variant, release the fastening of the scanning unit and scale unit, Page 19
- ▶ Attach the shipping brace, Page 17

HEIDENHAIN

DR. JOHANNES HEIDENHAIN GmbH

Dr.-Johannes-Heidenhain-Straße 5

83301 Traunreut, Germany

☎ +49 8669 31-0

☎ +49 8669 32-5061

info@heidenhain.de

Technical support ☎ +49 8669 32-1000

Measuring systems ☎ +49 8669 31-3104

service.ms-support@heidenhain.de

NC support ☎ +49 8669 31-3101

service.nc-support@heidenhain.de

NC programming ☎ +49 8669 31-3103

service.nc-pgm@heidenhain.de

PLC programming ☎ +49 8669 31-3102

service.plc@heidenhain.de

APP programming ☎ +49 8669 31-3106

service.app@heidenhain.de

www.heidenhain.com