



HEIDENHAIN



**Functional
Safety**

Product Information

KCI 1319

KBI 1335

Absolute Inductive
Rotary Encoders
without Integral Bearing

With additional measures
suitable for safety-related
applications with up to SIL3

KCI 1319, KBI 1335

Rotary encoders for absolute position values

- Robust inductive scanning principle
- Consisting of a scanning unit and a rotor unit

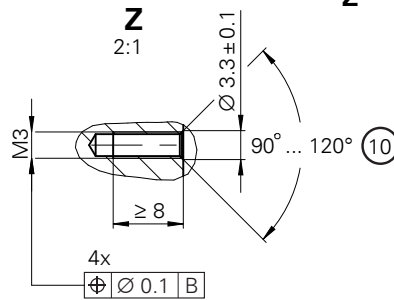
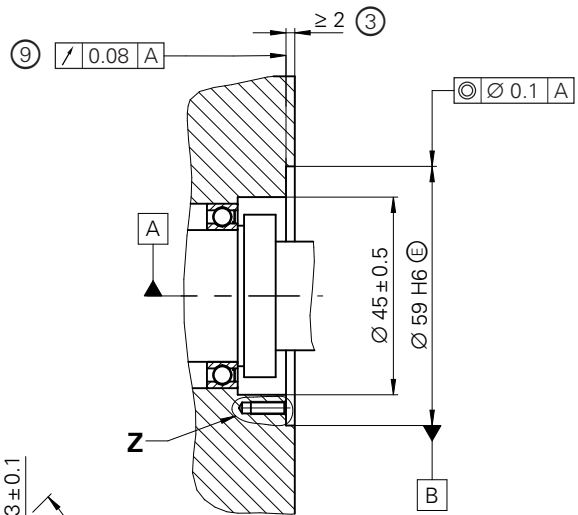
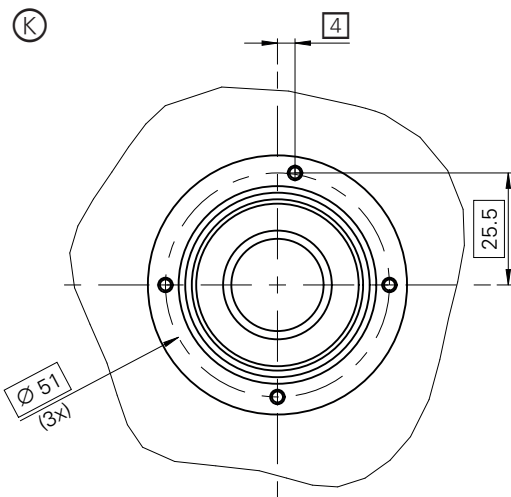
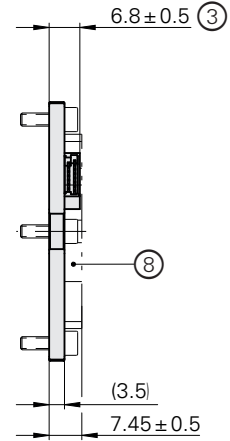
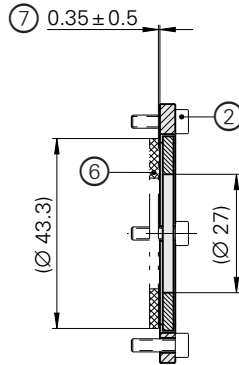
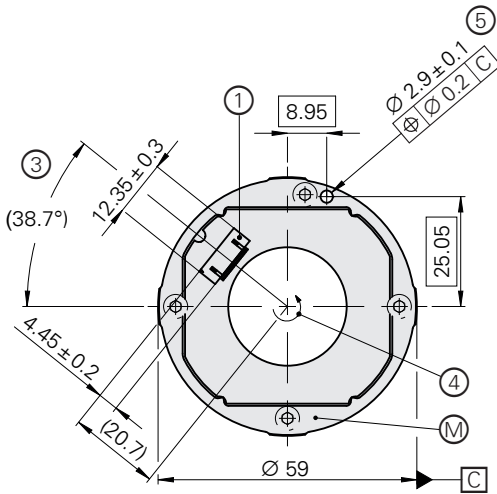

All drawings are shown with brakes released

mm
 Tolerancing ISO 8015
 ISO 2768 - m H
 < 6 mm: ±0.2 mm

- ▣ = Bearing of mating shaft
- ⊗ = Required mating dimensions
- ⊙ = Measuring point for operating temperature
- 1 = 15-pin PCB connector
- 2 = Cylinder head screw: ISO 4762 M3x10 – 8.8 MKL (4x)
- 3 = Ensure space for cable
- 4 = Direction of shaft rotation for ascending position values
- 5 = Additional and optional orientation possibility
- 6 = TK/TKN, separate, with different versions possible; for mounting, see the respective dimension drawing
- 7 = Mounting clearance between circular scale surface and flange surface; compensation of mounting tolerances and thermal expansion; dynamic motion permitted over entire range (with use of ATS software for mounting inspection, the display value for the mounting clearance is shown as 1 mm)
- 8 = Ensure space for electronics; see also the mating dimensions model
- 9 = Flange surface; ensure full-surface contact!
- 10 = Chamfer at start of thread is mandatory for material bonding anti-rotation lock

		Total height	Tolerance
AE KxI 13xx	Circular scale (screw-fastened version)	9.8	± 1.2
	Disk/hub assembly (press-fitted version)	14.6	

Rotor fastening via three axial countersunk head screws

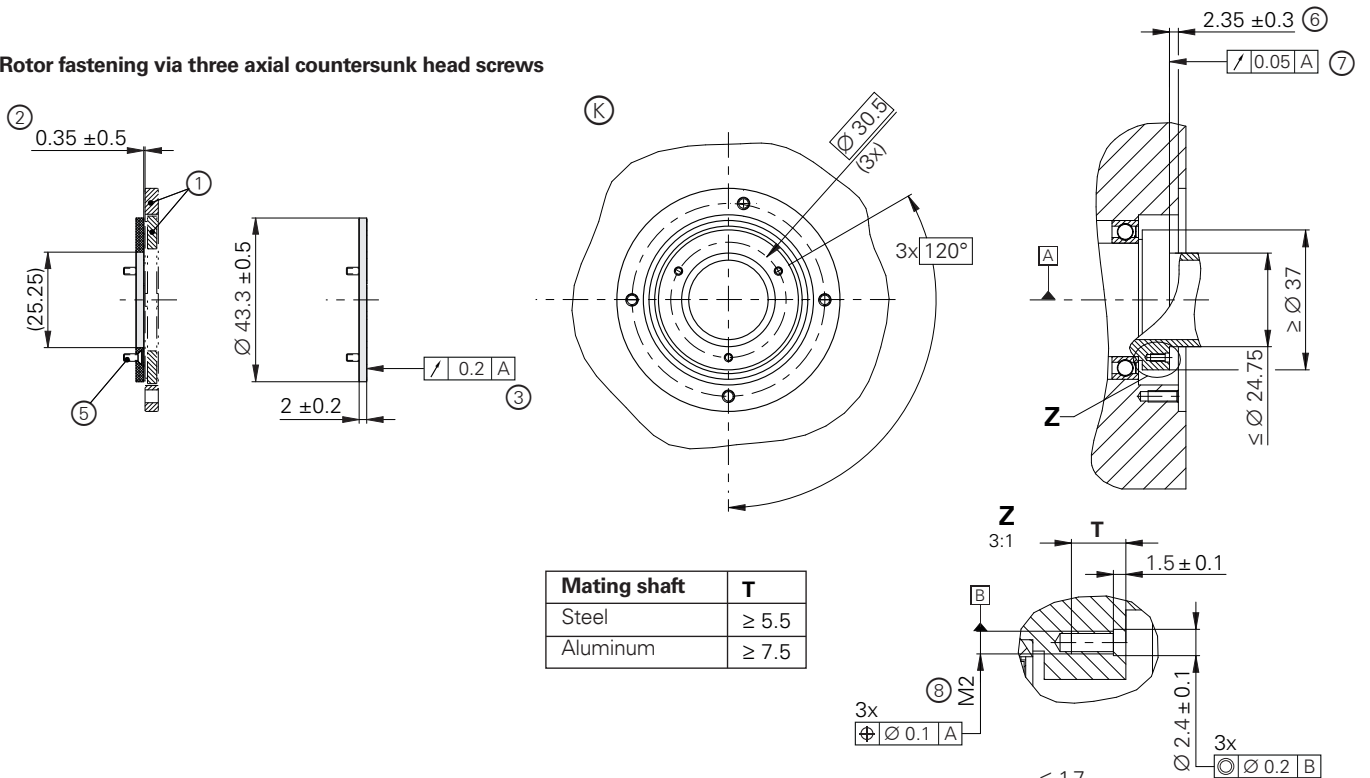

Rotor fastening via press-fitted hub

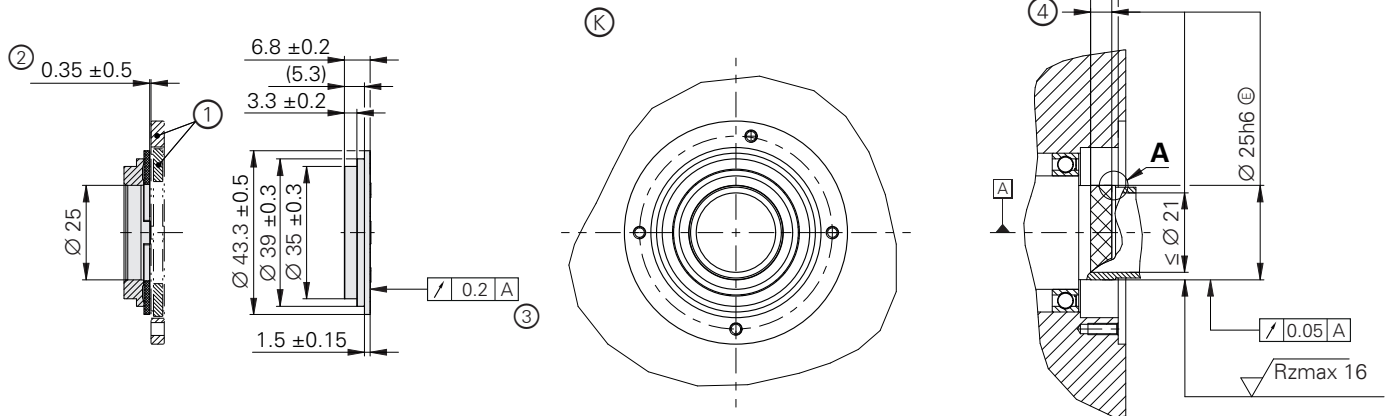

- ⊠ = Bearing of mating shaft
- ⊗ = Required mating dimensions
- 1 = Scanning unit, separate; different versions possible
- 2 = Mounting clearance between circular scale surface and flange surface of scanning unit; compensation of mounting tolerances and thermal expansion; dynamic motion permitted over entire range
- 3 = On the fine track (Ø 35.5 mm to Ø 42.4 mm) after screw-fastening/press-fitting
- 4 = For press-fitting parameters, see the Mounting Instructions
- 5 = *Steel shaft*: Countersunk head screw: M2x6 ISO 14581-A2-70;
Aluminum shaft: Countersunk head screw: M2x8 ISO 14581-A2-70;
protrusion of screw head not permitted
- 6 = Distance between scanning unit flange surface and circular scale surface
- 7 = Circular scale surface
- 8 = Use material bonding anti-rotation lock (at least medium strength)

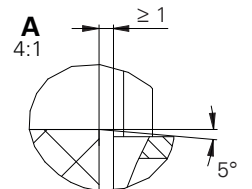

Specifications	KCI 1319 singleturn	KBI 1335 multiturn
Functional safety for applications with up to	As a single-encoder system for monitoring functions and control-loop functions: <ul style="list-style-type: none"> • SIL 2, as per EN 61508 (further basis for testing: IEC 61800-5-3) • Category 3, PL d, in accordance with EN ISO 13849-1:2015 With additional measures as per document 1000344, suitable for safety-related applications with up to SIL 3 or Category 4, PL e Safe in the singleturn range	
PFH ¹⁾	<i>SIL 2:</i> $\leq 15 \cdot 10^{-9}$ (probability of dangerous failure per hour) <i>SIL 3:</i> $\leq 2 \cdot 10^{-9}$	
Safe position ²⁾	<i>Encoder:</i> $\pm 0.88^\circ$ (safety-related measuring step SM = 0.35°) <i>Mechanical coupling:</i> 0° (fault exclusion for the loosening of the shaft coupling and stator coupling, designed for accelerations on the stator: $\leq 400 \text{ m/s}^2$; on the rotor: $\leq 600 \text{ m/s}^2$)	
Interface	EnDat 2.2	
Ordering designation	EnDat22	
Position values per revolution	524288 (19 bits)	
Revolutions	–	65536 (16 bits)
Calculation time t_{cal} Clock frequency	$\leq 5 \mu\text{s}$ $\leq 16 \text{ MHz}$	
System accuracy	$\pm 90''$	
Electrical connection	15-pin PCB connector (with connection for external temperature sensor)	
Cable length	$\leq 100 \text{ m}$ (see the EnDat description in the <i>Interfaces of HEIDENHAIN Encoders</i> brochure)	
Supply voltage	DC 3.6 V to 14 V	<i>Rotary encoder</i> U_P : DC 3.6 V to 14 V <i>Backup battery</i> U_{Bat} : DC 3.6 V to 5.25 V
Power consumption ³⁾ (maximum)	<i>At 3.6 V:</i> $\leq 650 \text{ mW}$ <i>At 14 V:</i> $\leq 700 \text{ mW}$	
Current consumption (typical)	<i>At 5 V:</i> 95 mA (without load)	<i>Normal operation at 5 V:</i> 95 mA (without load) <i>Backup battery:</i> 200 μA (rotating shaft) ⁴⁾ 20 μA (at standstill)
Part number	AE KCI 1319 scanning unit 1314405-01 Circular scale (screw-fastened version) 1314410-01 Disk/hub assembly (press-fitted version) 1314409-01	AE KBI 1335 scanning unit 1314406-01 Circular scale (screw-fastened version) 1314410-01 Disk/hub assembly (press-fitted version) 1314409-01

¹⁾ For use at $\leq 1000 \text{ m}$ above sea level ($\leq 6000 \text{ m}$ above sea level upon request)

²⁾ Further tolerances may arise in the downstream electronics after position value comparison (contact mfr.)

³⁾ See *General electrical information* in the *Interfaces of HEIDENHAIN Encoders* brochure or at www.heidenhain.com

⁴⁾ At $T = 25^\circ\text{C}$; $U_{\text{Bat}} = 3.6 \text{ V}$

Specifications	KCI 1319 singletum	KBI 1335 multitum
Rotor*	Circular scale with inside hub diameter of 25 mm (press-fitted version) Circular scale with circular hole pattern diameter of 30.5 mm (screw-fastened version)	
Shaft speed	≤ 10000 rpm	
Moment of inertia	<i>Disk/hub assembly:</i> $6.3 \cdot 10^{-6} \text{ kgm}^2$ <i>Circular scale:</i> $1.16 \cdot 10^{-6} \text{ kgm}^2$	
Angular acceleration of rotor ¹⁾	≤ $1 \cdot 10^5 \text{ rad/s}^2$	
Axial motion of measured shaft	≤ ±0.5 mm	
Vibration 55 Hz to 2000 Hz ²⁾ Shock 6 ms	<i>Stator:</i> ≤ 400 m/s^2 ; <i>rotor:</i> ≤ 600 m/s^2 (EN 60068-2-6) ≤ 2000 m/s^2 (EN 60068-2-27)	
Operating temperature	−40 °C to 115 °C	
Trigger threshold for exceeded temperature error message	130 °C (measuring accuracy of internal temperature sensor: ±1 K)	
Relative humidity	≤ 93% (40 °C/21 d as per EN 60068-2-78), condensation excluded	
Protection rating EN 60529	IP00 (read about insulation under <i>General electrical information</i> in the <i>Encoders for Servo Drives</i> brochure)	
Mass	AE + TK ≈ 0.03 kg AE + TKN ≈ 0.05 kg	

* Please select when ordering

¹⁾ With multiturn functionality in normal operation; maximum permissible acceleration in backup-battery mode upon request

²⁾ 10 Hz to 55 Hz, constant over 6.5 mm peak to peak (stator), 10 mm peak to peak (rotor)

Mounting

The KCI 1319/KBI 1335 is mounted either via screw-fastening of the circular scale or through press-fitting of the disk/hub assembly, followed by mounting of the scanning unit. The disk/hub assembly is thereby either press-fitted onto the shaft, or the circular scale is screw-fastened to the given shaft with three screws. The scanning unit is aligned and mounted via four holes on the customer's mounting surface.

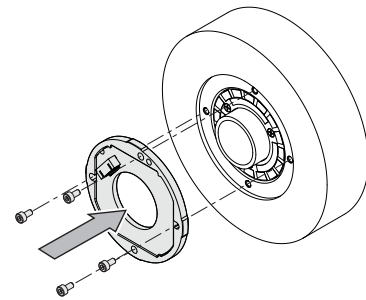
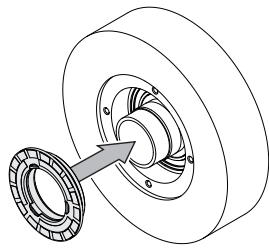
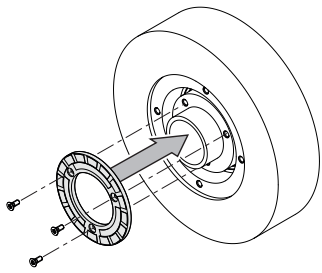

The press-fitting process may be performed only once for each disk/hub assembly. For press-fitting, adhere to the material properties and conditions for the mating surface stated in the relevant documents for proper use. These requirements must be followed, even when new disk/hub assemblies are press-

fitted onto customer shafts that have already been used. Once the lower limit of the press-fit force has been exceeded, the press-fit force being applied must remain within the specified range for the rest of the procedure, including until the final position is reached.

The following material properties and conditions must be complied with for the customer-side mounting design:

	Mating stator	Mating shaft	
Material	Aluminum	Steel	Aluminum
Tensile strength R_m	$\geq 220 \text{ N/mm}^2$	$\geq 600 \text{ N/mm}^2$	$\geq 220 \text{ N/mm}^2$
Yield strength $R_{p0.2}$ or yield point R_e	–	$\geq 400 \text{ N/mm}^2$	–
Shear strength τ_m	130 N/mm^2	$\geq 390 \text{ N/mm}^2$	$\geq 130 \text{ N/mm}^2$
Interface pressure P_G	$\geq 250 \text{ N/mm}^2$	$\geq 660 \text{ N/mm}^2$	$\geq 250 \text{ N/mm}^2$
Modulus of elasticity E (at 20 °C)	70 kN/mm^2 to 75 kN/mm^2	200 kN/mm^2 to 215 kN/mm^2	70 kN/mm^2 to 75 kN/mm^2
Coefficient of thermal expansion α_{therm} (at 20 °C)	$\leq 25 \cdot 10^{-6} \text{ K}^{-1}$	<i>Screw-fastened version:</i> $10 \cdot 10^{-6} \text{ K}^{-1}$ to $17 \cdot 10^{-6} \text{ K}^{-1}$ <i>Press-fitted version:</i> $10 \cdot 10^{-6} \text{ K}^{-1}$ to $12 \cdot 10^{-6} \text{ K}^{-1}$	<i>Screw-fastened version:</i> $\leq 25 \cdot 10^{-6} \text{ K}^{-1}$ <i>Press-fitted version:</i> Not available
Surface roughness R_z	$\leq 16 \mu\text{m}$		
Friction values	Lubrication at the joint surfaces is recommended. Mounting surfaces must be clean and free of grease. Use screws and washers from HEIDENHAIN in their condition as delivered.		
Tightening procedure	Use a signal-emitting torque wrench as per DIN EN ISO 6789, with an accuracy of $\pm 6\%$		
Mounting temperature	15 °C to 35 °C		

Mounting accessories

Screws

Screws (fastening screws) are not included in delivery; the M3x10 screw with material bonding anti-rotation lock can be ordered separately.

KCI 1319 KBI 1335	Screws	Quantity	
Screw for fastening the scanning unit	ISO 4762 – M3x10 – 8.8 – MKL ¹⁾	ID 202264-87	10 or 100
Fastening screw for circular scale with a steel mating shaft	ISO 14581 – M2x6 – A2 – 70 ²⁾	–	–
Fastening screw for circular scale with an aluminum mating shaft	ISO 14581 – M2x8 – A2 – 70 ²⁾	–	–

¹⁾ With coating for material bonding anti-rotation lock (for information on use, see the *Encoders for Servo Drives* brochure)

²⁾ Without anti-rotation lock; use at least a medium-strength material bonding anti-rotation lock

Mounting aid

To avoid damage to the cable, use the mounting aid to connect and disconnect the cable assembly. Apply pulling force only to the connector of the cable assembly and not to the wires.



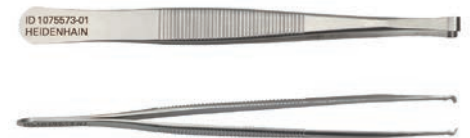

ID 1075573-01

For more mounting information and mounting aids, see the Mounting Instructions and the *Encoders for Servo Drives* brochure. The installation can be inspected with the PWM 21 and the ATS software (see document 1082415).

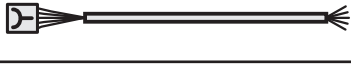

Electrical connection

Cables

Output cables inside the motor housing with TPE single wires ($8 \times 0.16 \text{ mm}^2$) and net sleeve without shield		
Output cable with 15-pin PCB connector and 8-pin M12 straight flange socket (male) with TPE single wires for temperature sensor ($2 \times 0.16 \text{ mm}^2$)		ID 1119952-xx
Output cable with 15-pin PCB connector and 8-pin M12 straight flange socket (male)		ID 804201-xx
Output cable with 15-pin PCB connector and TPE single wires for temperature sensor ($2 \times 0.16 \text{ mm}^2$), and stripped cable end		ID 1119958-xx ¹⁾
Output cable inside the motor housing with TPE single wires ($8 \times 0.16 \text{ mm}^2$) and heat shrink tubing without a shield		
Output cable with 15-pin PCB connector and stripped cable end		ID 640055-xx ¹⁾
Output cable for HMC 6: $\varnothing 3.7 \text{ mm EPG } 1 \times (4 \times 0.06 \text{ mm}^2) + 4 \times 0.06 \text{ mm}^2$		
Output cable with 15-pin PCB connector and contact insert for 6-pin HMC 6 hybrid connecting element (male) with TPE single wires for temperature sensor ($2 \times 0.16 \text{ mm}^2$), with cable clamp for shield connection		ID 1072652-xx









¹⁾ Connecting element must be suitable for the maximum clock frequency used

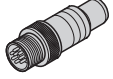

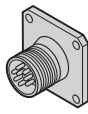
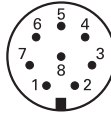
Further information:

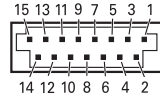
For connecting cables and adapter cables, see the *Cables and Connectors* brochure.

Pin layout for KCI 1319







8-pin M12 coupling or flange socket					15-pin PCB connector						
											
	Power supply				Serial data transmission				Other signals		
	8	2	5	1	3	4	7	6	/	/	
	13	11	14	12	7	8	9	10	5	6	
	U_P	Sensor U _P	0V	Sensor 0V	DATA	DATA	CLOCK	CLOCK	T+	T-	
	Brown/ Green	Blue	White/ Green	White	Gray	Pink	Violet	Yellow	Brown	Green	

Cable shield connected with housing; **U_P** = Power supply; **T** = Temperature

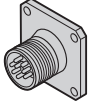
Sensor: The sense line is connected in the encoder with the corresponding power line.

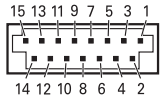
Vacant pins or wires must not be used!

Pin layout for KBI 1335

8-pin M12 flange socket					15-pin PCB connector						
											
	Power supply				Serial data transmission				Other signals		
	13	11	14	12	7	8	9	10	5	6	
	8	2	5	1	3	4	7	6	/	/	
	U_P	U_{BAT}	0V¹⁾	0V_{BAT}¹⁾	DATA	DATA	CLOCK	CLOCK	T+	T-	
	Brown/ Green	Blue	White/ Green	White	Gray	Pink	Violet	Yellow	Brown	Green	

U_P = Power supply; **U_{BAT}** = External buffer battery (false polarity can result in damage to the encoder)

Vacant pins or wires must not be used!

¹⁾ Connected inside encoder

HEIDENHAIN

DR. JOHANNES HEIDENHAIN GmbH

Dr.-Johannes-Heidenhain-Str. 5

83301 Traunreut, Germany

☎ +49 8669 31-0

FAX +49 8669 32-5061

info@heidenhain.de

www.heidenhain.com

This Product Information document supersedes all previous editions, which thereby become invalid. The basis for ordering from HEIDENHAIN is always the Product Information document edition valid when the order is placed.



More information:

Comply with the requirements described in the following documents to ensure correct and intended operation:

- Operating Instructions 1357580
- Technical Information *Safety-Related Position Measuring Systems* 596632-xx
- Implementation in a safe control or inverter 533095-xx
- Supplementary *Catalog of Measures (SIL 3, PLe)* 1000344-xx