

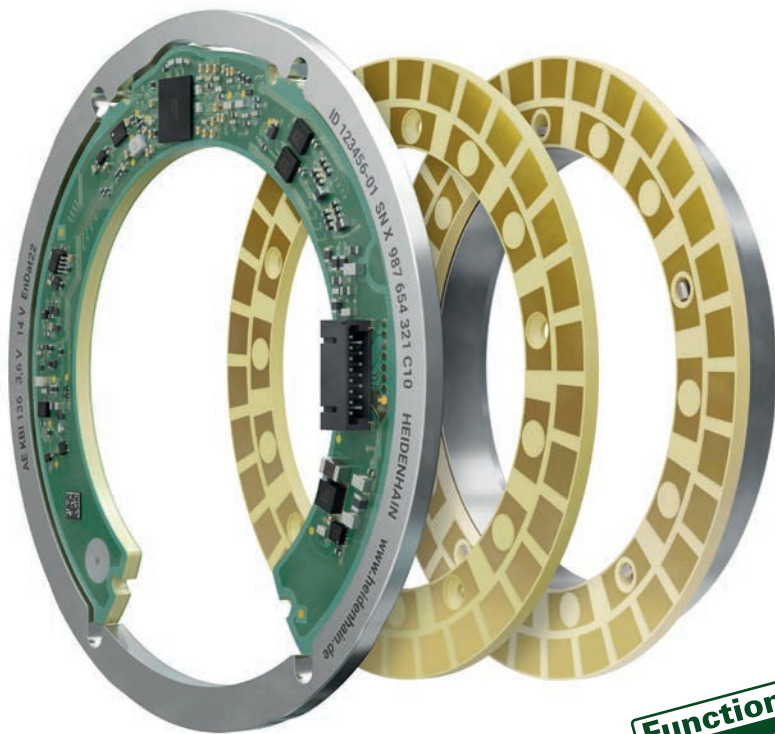

HEIDENHAIN



**Functional
Safety**

Product Information

KCI 120

KBI 136

Absolute Inductive Rotary Encoders without Integral Bearing

With additional measures:
suitable for safety-related
applications with up to SIL3

EnDat 2.2

08/2024

KCI 120, KBI 136

Rotary encoders for absolute position feedback

- Robust inductive scanning principle
- Consisting of a scanning unit and a rotor unit

Functional Safety

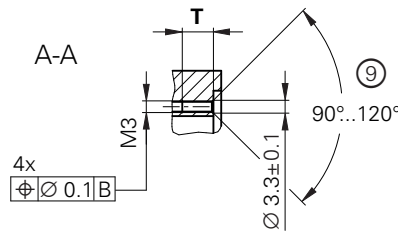
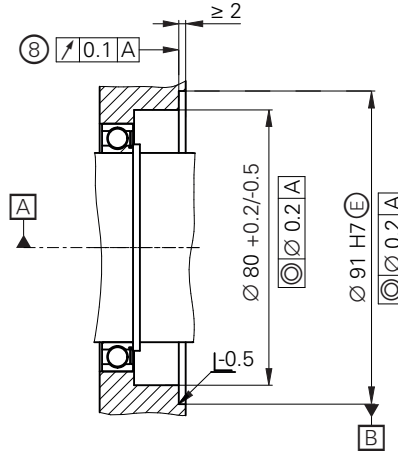
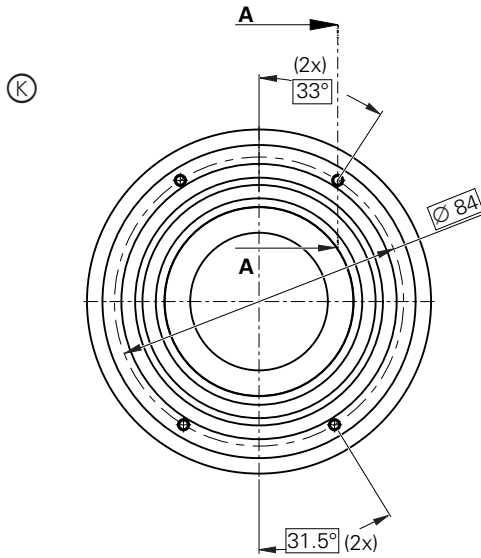
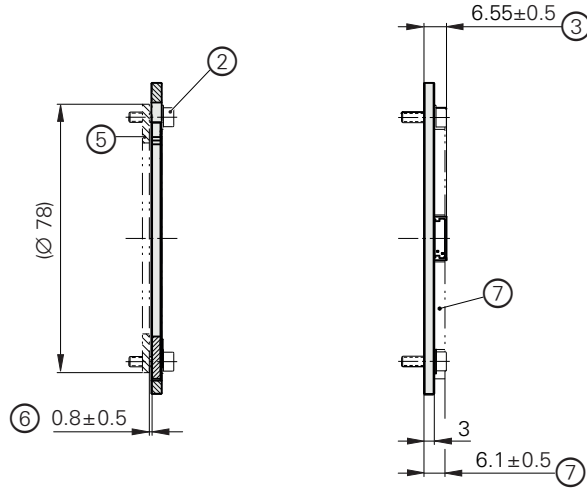
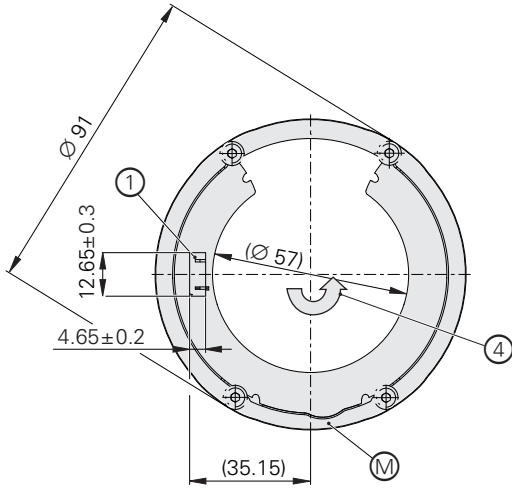
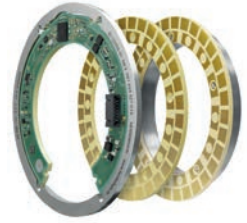

Mating stator	T
Steel	≥ 6
Aluminum	≥ 8

- ▣ = Bearing of mating shaft
- ⊙ = Required mating dimensions
- ⊗ = Measuring point for operating temperature and vibration
- 1 = 15-pin PCB connector
- 2 = Cylinder head screw
- 3 = Ensure space for PCB connector and cable
- 4 = Direction of shaft rotation for ascending position values
- 5 = TK/TKN, separate, with different versions possible; for mounting, see the respective dimension drawing
- 6 = Max. permissible deviation between circular scale surface and flange surface; compensation of mounting tolerances and thermal expansion; dynamic motion permitted over the entire range (when the ATS software is used for the mounting inspection, the display value for the mounting clearance is shown as 1 mm)
- 7 = Ensure space for electronics; see also the mating dimensions model
- 8 = Flange surface; ensure full-surface contact!
- 9 = Chamfer at start of thread is mandatory for material-bonding anti-rotation lock

* Instructions: use screw with material-bonding anti-rotation lock as per DIN 267-27 (not included in delivery); see *General mechanical information* in the *Encoders for Servo Drives* brochure

mm

 Tolerancing ISO 8015
 ISO 2768:1989-mH
 ≤ 6 mm: ±0.2 mm

Rotor fastening via five axial countersunk head screws

Mating shaft	T
Steel	≥ 5.5
Aluminum	≥ 7.5

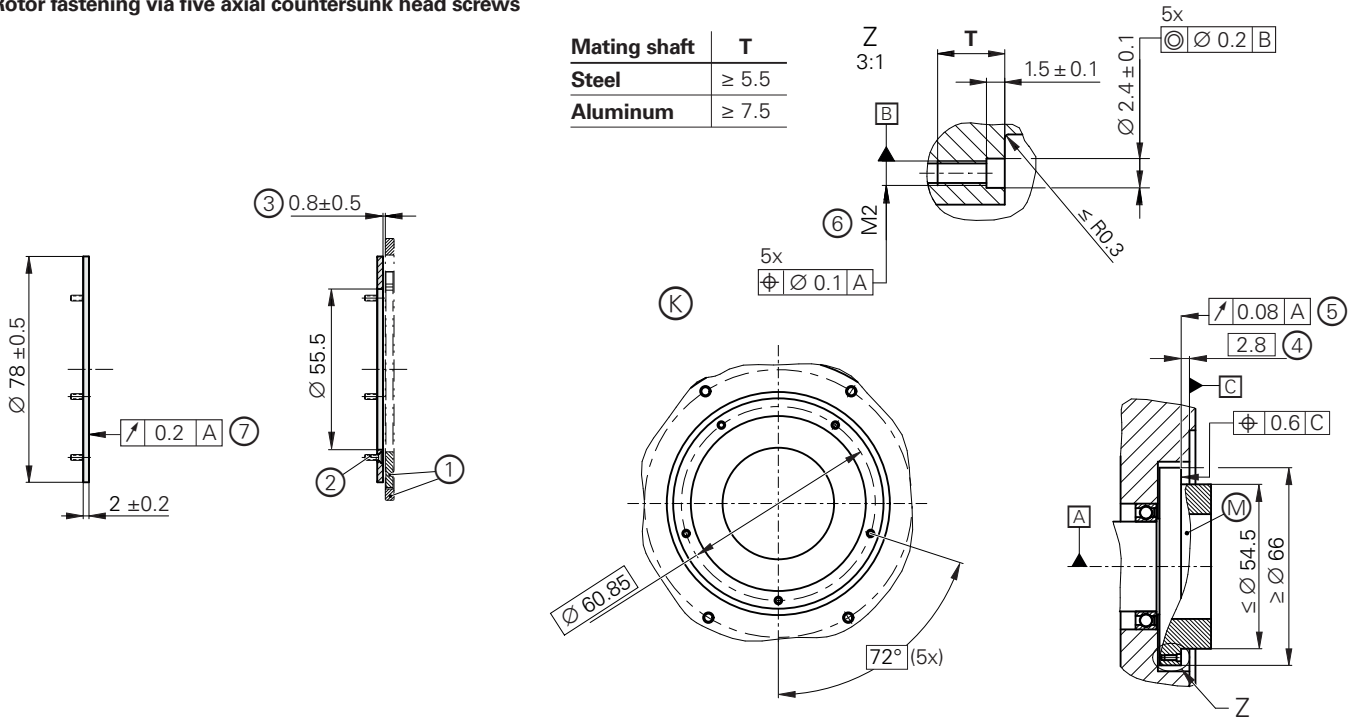

Rotor fastening via press-fitted hub

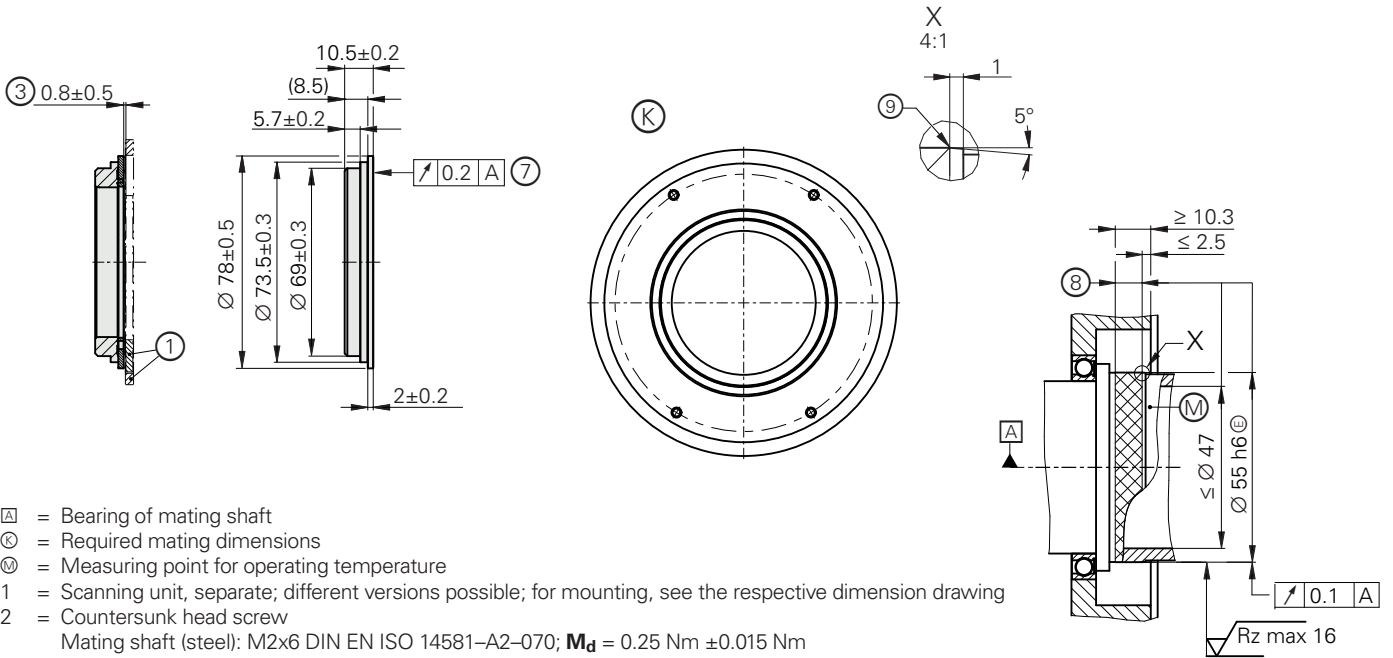

- ⊠ = Bearing of mating shaft
- ⊙ = Required mating dimensions
- ⊕ = Measuring point for operating temperature
- 1 = Scanning unit, separate; different versions possible; for mounting, see the respective dimension drawing
- 2 = Countersunk head screw
Mating shaft (steel): M2x6 DIN EN ISO 14581-A2-070; $M_d = 0.25 \text{ Nm} \pm 0.015 \text{ Nm}$
Mating shaft (aluminum): M2x8 DIN EN ISO 14581-A2-070; $M_d = 0.25 \text{ Nm} \pm 0.015 \text{ Nm}$
Protrusion of screw head not permitted
- 3 = Maximum permissible deviation between circular scale surface and flange surface of the scanning unit; compensation of mounting tolerances and thermal expansion; dynamic motion permitted over the entire range (when the ATS software is used for the mounting inspection, the display value for the mounting clearance is shown as 1 mm)
- 4 = Distance between scanning unit flange surface and circular scale surface
- 5 = Circular scale surface
- 6 = Use suitable material bonding anti-rotation lock (at least medium strength)
- 7 = On the fine track (Ø 68 mm to Ø 77 mm), after screw-fastening/press-fitting
- 8 = For press-fitting parameters, see the Mounting Instructions
- 9 = Rounded transition to the fit surface: $R = 0.5 \text{ mm}$

mm

 Tolerancing ISO 8015
 ISO 2768:1989-mH
 ≤ 6 mm: ±0.2 mm

Specifications	KCI 120 singleturn	KBI 136 multiturn
Functional safety for applications with up to	As a single-encoder system for monitoring functions and control-loop functions: <ul style="list-style-type: none"> • SIL 2, as per EN 61508 (further basis for testing: IEC 61800-5-3) • Category 3, PL d, in accordance with EN ISO 13849-1:2015 With additional measures as per document 1000344, suitable for safety-related applications with up to SIL 3 or Category 4, PL e Safe in the singleturn range	
PFH	$SIL\ 2: \leq 15 \cdot 10^{-9}$ (probability of dangerous failure per hour) $SIL\ 3: \leq 2 \cdot 10^{-9}$	
Safe position ¹⁾	<i>Encoder</i> : $\pm 0.88^\circ$ (safety-related measuring step $SM = 0.35^\circ$) <i>Mechanical coupling</i> : 0° (fault exclusion for loosening of shaft and stator coupling, designed for accelerations of $\leq 400\text{ m/s}^2$ on the stator and $\leq 600\text{ m/s}^2$ on the rotor)	
Interface	EnDat 2.2	
Ordering designation	EnDat22	
Position values per revolution	1 048 576 (20 bits)	
Revolutions	–	65 563 (16 bits)
Calculation time t_{cal} Clock frequency	$\leq 5\ \mu\text{s}$ $\leq 16\ \text{MHz}$	
System accuracy	$\pm 40''$	
Electrical connection	15-pin PCB connector (with connection for external temperature sensor)	
Cable length	$\leq 100\ \text{m}$ (see EnDat description in the <i>Interfaces of HEIDENHAIN Encoders</i> brochure)	
Supply voltage	DC 3.6 V to 14 V	<i>Rotary encoder</i> U_P : DC 3.6 V to 14 V <i>Backup battery</i> U_{Bat} : DC 3.6 V to 5.25 V
Power consumption ²⁾ (max.)	At 3.6 V: $\leq 650\ \text{mW}$ At 14 V: $\leq 700\ \text{mW}$	
Current consumption (typical)	At 5 V: 95 mA (without load)	<i>Normal operation at 5 V</i> : 95 mA (without load) <i>Backup battery</i> : 200 μA (rotating shaft) ³⁾ 20 μA (at standstill)
ID number	AE KCI 120 scanning head 1402900-01	AE KBI 136 scanning head 1402901-01
	Circular scale (screw-fastened version) 1402903-01 (55.5 mm) Disk/hub assembly (press-fitted version) 1402902-01 (55 mm)	

¹⁾ Further tolerances may arise in the downstream electronics after position value comparison (contact mfr.)

²⁾ See *General electrical information* in the *Interfaces of HEIDENHAIN Encoders* brochure, or visit www.heidenhain.com

³⁾ At $T = 25\ ^\circ\text{C}$; $U_{Bat} = 3.6\ \text{V}$

Specifications	KCI 120 singleturn	KBI 136 multiturn
Rotor*	Press-fitted disk/hub assembly (hub inside diameter: 55 mm) Screw-fastened circular scale (inside diameter: 55.5 mm)	
Shaft speed	<i>KCI 120</i> : ≤ 10 000 rpm <i>KBI 136</i> : ≤ 6000 rpm	
Moment of inertia	<i>Disk/hub assembly</i> : $108 \cdot 10^{-6} \text{ kgm}^2$ <i>Circular scale</i> : $10.5 \cdot 10^{-6} \text{ kgm}^2$	
Angular acceleration of rotor ¹⁾	≤ $1 \cdot 10^5 \text{ rad/s}^2$	
Axial motion of measured shaft	≤ ±0.5 mm	
Vibration 55 Hz to 2000 Hz ²⁾ Shock 6 ms	<i>Stator</i> : ≤ 400 m/s ² ; <i>rotor</i> : ≤ 600 m/s ² (EN 60068-2-6) ≤ 2000 m/s ² (EN 60068-2-27)	
Operating temperature	−40 °C to 115 °C	
Relative humidity	≤ 93 % (40 °C/21 d as per EN 60068-2-78); without condensation	
Protection EN 60529	IP00	
Mass	≈ 0.15 kg (scanning unit + disk/hub assembly) ≈ 0.05 kg (scanning unit + circular scale)	

* Please select when ordering

¹⁾ With multiturn functionality in normal operation; maximum permissible acceleration in backup-battery mode upon request

²⁾ 10 Hz to 55 Hz, 4.9 mm constant peak to peak

Installation

The KCI 120/KBI 136 is mounted either via screw-fastening of the circular scale or through press-fitting of the disk/hub assembly, followed by mounting of the scanning unit. Either the disk/hub assembly is press-fitted onto the shaft or the circular scale is screw-fastened to the given shaft with five screws. The scanning unit is aligned and mounted via four holes on the customer's mounting surface.

The press-fitting process may be performed only once for each disk/hub assembly. For press-fitting, adhere to the material properties and conditions for the mating surface stated in the relevant documents for proper use. These requirements must be followed, even when new disk/hub assemblies are

press-fitted onto customer shafts that have already been used. The maximum pressing force must not be exceeded throughout the press-fitting procedure. Starting at one millimeter before reaching the final position, the pressing force must not fall below the minimum pressing force.

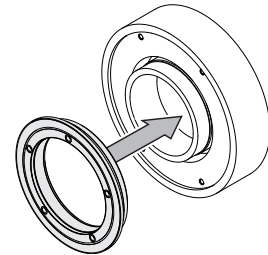
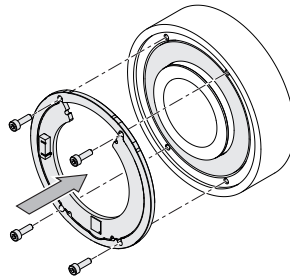
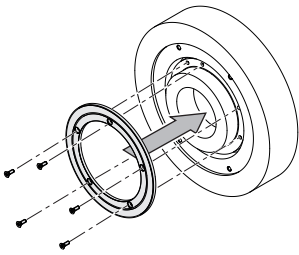

The following material properties and conditions must be complied with when customers plan and execute installation:

	Mating shaft ¹⁾ , mating stator	Mating shaft, mating stator
Material	Aluminum	Steel
Tensile strength R_m	$\geq 220 \text{ N/mm}^2$	$\geq 600 \text{ N/mm}^2$
Yield strength $R_{p0.2}$ or yield point R_e	–	$\geq 400 \text{ N/mm}^2$
Shear strength τ_a	130 N/mm^2	$\geq 390 \text{ N/mm}^2$
Interface pressure P_G	$\geq 250 \text{ N/mm}^2$	$\geq 660 \text{ N/mm}^2$
Modulus of elasticity E (at 20 °C)	70 kN/mm^2 to 75 kN/mm^2	200 kN/mm^2 to 215 kN/mm^2
Coefficient of thermal expansion α_{therm} (at 20 °C)	$\leq 25 \cdot 10^{-6} \text{ K}^{-1}$	<i>Screw-fastened version:</i> $10 \cdot 10^{-6} \text{ K}^{-1}$ to $17 \cdot 10^{-6} \text{ K}^{-1}$ <i>Press-fitted version:</i> $10 \cdot 10^{-6} \text{ K}^{-1}$ to $12 \cdot 10^{-6} \text{ K}^{-1}$
Surface roughness R_z	$\leq 16 \mu\text{m}$	
Friction values	Mounting surfaces must be clean and free of grease. Use screws and washers from HEIDENHAIN in their condition as delivered.	
Tightening procedure	Use a signal-emitting torque wrench in accordance with DIN EN ISO 6789, with an accuracy of $\pm 6\%$	
Mounting temperature	15 °C to 35 °C	

¹⁾ Only when screw-fastened circular scale is used

Mounting accessories

Screws

Screws (mounting screws) are not included in delivery. M3x8 and M3x10 screws with material bonding anti-rotation lock can be ordered separately.

KCI 120 KBI 136	Mating shaft, mating stator	Screws		Quantity
Screw for fastening the scanning unit	Steel	ISO 4762- M3x8 -8.8- MKL ¹⁾	ID 202264-67	1
	Aluminum	ISO 4762- M3x10 -8.8- MKL ¹⁾	ID 202264-87	10 or 100
Mounting screw for circular scale	Steel	ISO 14581- M2x6 -A2-070 ²⁾	–	–
	Aluminum	ISO 14581- M2x8 -A2-070 ²⁾	–	–

¹⁾ With coating for material-bonding anti-rotation lock

(for information on usage, see the *Encoders for Servo Drives* brochure)

²⁾ Screw without material-bonding anti-rotation lock; a material-bonding anti-rotation lock of at least medium strength must be used

Mounting aid

To avoid damage to the cable, use the mounting aid to connect and disconnect the cable assembly. Apply pulling force solely to the connector of the cable assembly and not to the wires.



ID 1075573-01





For more mounting information and mounting aids, see the Mounting Instructions and the *Encoders for Servo Drives* brochure. The mounting quality can be inspected with the PWM 21 and the ATS software (see Document 1082415).

Electrical connection

Cables

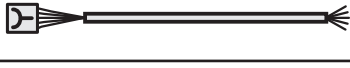
Output cables inside the motor housing with TPE single wires ($8 \times 0.16 \text{ mm}^2$) and net sleeve without shield		
With 15-pin PCB connector and 8-pin M12 straight flange socket (male) with TPE single wires for temperature sensor ($2 \times 0.16 \text{ mm}^2$)		ID 1119952-xx
With 15-pin PCB connector and 8-pin M12 straight flange socket (male)		ID 804201-xx
With 15-pin PCB connector with TPE single wires for temperature sensor ($2 \times 0.16 \text{ mm}^2$) and stripped cable end		ID 1119958-xx ¹⁾

Output cable inside the motor housing with TPE single wires ($8 \times 0.16 \text{ mm}^2$) and heat shrink tubing without a shield		
With 15-pin PCB connector and stripped cable end		ID 640055-xx ¹⁾

Output cable for HMC 6: $\varnothing 3.7 \text{ mm EPG } 1 \times (4 \times 0.06 \text{ mm}^2) + 4 \times 0.06 \text{ mm}^2$		
With 15-pin PCB connector and contact insert for 6-pin HMC 6 hybrid connector (male) with TPE single wires for temperature sensor ($2 \times 0.16 \text{ mm}^2$), with cable clamp for shield connection		ID 1072652-xx







¹⁾ Connecting elements must be suitable for the maximum clock frequency used

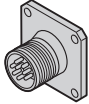

More information:

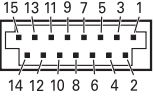
For connecting cables and adapter cables, see the *Cables and Connectors* brochure.

Pin layout for KCI 120







8-pin M12 flange socket					15-pin PCB connector					
										
	Power supply				Serial data transmission				Other signals	
	8	2	5	1	3	4	7	6	/	/
	13	11	14	12	7	8	9	10	5	6
	U _P	Sensor U _P	0V	Sensor 0V	DATA	$\overline{\text{DATA}}$	CLOCK	$\overline{\text{CLOCK}}$	T+	T-
	Brown/ Green	Blue	White/ Green	White	Gray	Pink	Violet	Yellow	Brown	Green

Cable shield connected to housing; **U_P** = Power supply voltage; **T** = Temperature

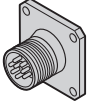
Sensor: The sense line is connected in the encoder with the corresponding power line.

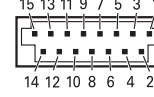
Vacant pins or wires must not be used!

Pin layout for KBI 136

8-pin M12 flange socket					15-pin PCB connector					
										
	Power supply				Serial data transmission				Other signals	
	8	2	5	1	3	4	7	6	/	/
	13	11	14	12	7	8	9	10	5	6
	U _P	U _{BAT}	0V ¹⁾	0V _{BAT} ¹⁾	DATA	$\overline{\text{DATA}}$	CLOCK	$\overline{\text{CLOCK}}$	T+	T-
	Brown/ Green	Blue	White/ Green	White	Gray	Pink	Violet	Yellow	Brown	Green

U_P = Power supply; **U_{BAT}** = External buffer battery (false polarity can result in damage to the encoder)

Vacant pins or wires must not be used!

¹⁾ Connected inside encoder

HEIDENHAIN

DR. JOHANNES HEIDENHAIN GmbH

Dr.-Johannes-Heidenhain-Straße 5

83301 Traunreut, Germany

☎ +49 8669 31-0

FAX +49 8669 32-5061

info@heidenhain.de

www.heidenhain.com

This Product Information document supersedes all previous editions, which thereby become invalid. The basis for ordering from HEIDENHAIN is always the Product Information document edition valid when the order is placed.



More information:

Comply with the requirements described in the following documents to ensure correct and intended operation:

- Operating Instructions: AE KCI 120, KBI 136 1422970-xx
- Operating Instructions: TK/TKN KCI 120, KBI 136 1424003-xx