

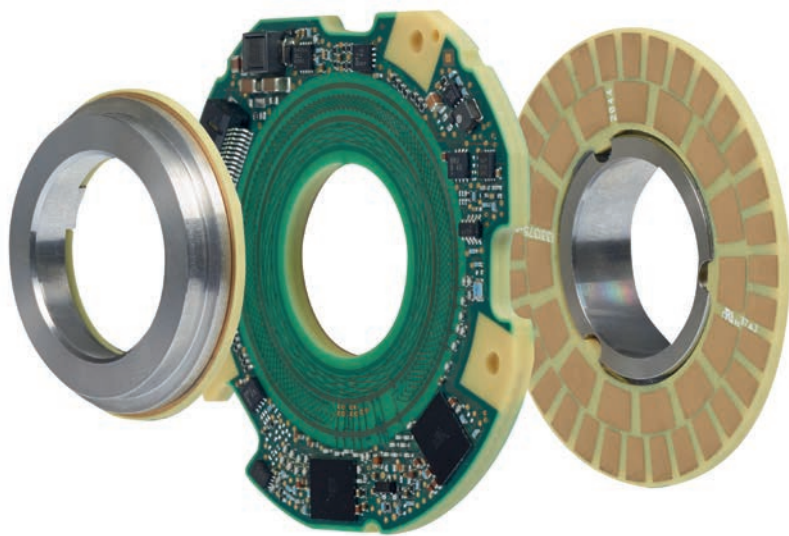

# HEIDENHAIN



Product Information

## **KCI 120 Dplus** **KBI 136 Dplus**

Absolute Inductive Rotary  
Encoders with Additional  
Functionality

Position measurement at  
the output side

# KCI 120 Dplus, KBI 136 Dplus

Absolute inductive rotary encoders with additional functionality

- Robust inductive scanning principle
- Consisting of an AE scanning unit and two rotor units (TKN disk/hub assembly or TK circular scale)
- Second position measurement on the output side (alternatively also with multiturn)

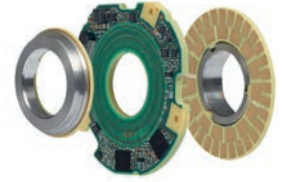

Circular scale (screw-fastened)

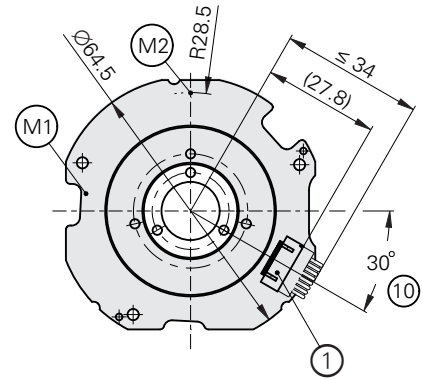
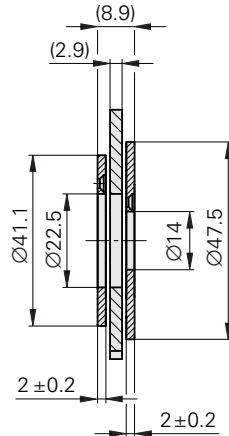
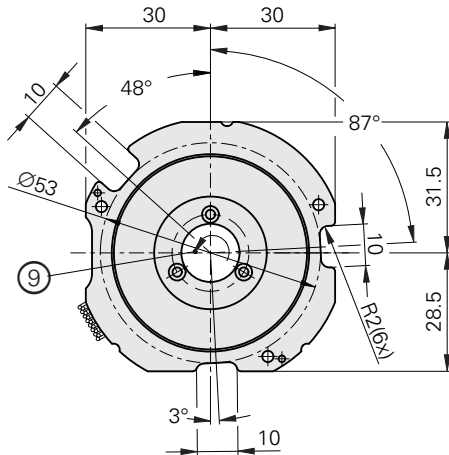

▣ = Bearing of Rotor A

▣ = Bearing of Rotor B

⊙ = Required mating dimensions

M1 = Measuring point for operating temperature

M2 = Measuring point for vibration

1 = 15-pin PCB connector

2 = Shown with customer side

3 = Rotor A mounting dimension; tolerance includes compensation of mounting tolerances and thermal expansion

4 = Rotor B mounting dimension; tolerance includes compensation of mounting tolerances and thermal expansion

5 = Distance between scanning unit flange surface and circular scale surface

6 = Circular scale surface

7 = Cylinder head screw

Steel mating stator: 3x DIN EN ISO 4762 – M2.5x8 – 8.8 – MKL or DIN EN ISO 14583 – M2.5x12 – 8.8 – MKL\* with DIN 6796 – 2.5 – FSt spring washer and washer (ID1334909-01);

**M<sub>d</sub>** = 0.7 Nm ±0.05 Nm; note the orientation of the spring washer!

Aluminum mating stator: 3x DIN EN ISO 4762 or DIN EN ISO 14583 – M2.5x12 – 8.8 – MKL\* with DIN 6796 – 2.5 – FSt spring washer and washer (ID1334909-01);

**M<sub>d</sub>** = 0.7 Nm ±0.05 Nm; note the orientation the spring washer!

8 = Chamfer at start of thread is mandatory for material bonding anti-rotation lock

9 = Direction of rotation of both shafts for ascending position values

10 = Ensure space for cable

11 = Ensure space for electronics; see also the mating dimensions model

12 = Avoid collision with the scanning unit

13 = Gap for air and creepage distances > 1 mm

14 = Countersunk screws

Steel mating shaft: 6x DIN EN ISO 14581 – M2x6 – A2 – 070; aluminum mating shaft: 6x DIN EN ISO 1451 – M2x8 – A2 – 070; protrusion of screw head not permitted; use suitable material bonding anti-rotation lock (at least medium strength)\*

15 = Free of burrs

\*Instructions for use: Regarding screw with material-bonding anti-rotation lock as per DIN 267-27, see *General mechanical information* in the *Rotary Encoders* brochure (not included in delivery!)

mm



Tolerancing ISO 8015  
ISO 2768:1989-mH  
≤ 6 mm: ±0.2 mm

Mating shaft	T	L
Steel	≥ 5.5	≥ 9
Aluminum	≥ 7.5	≥ 5

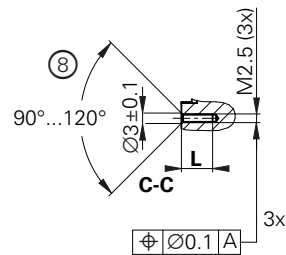
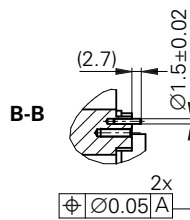
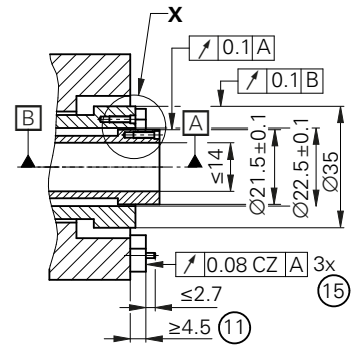
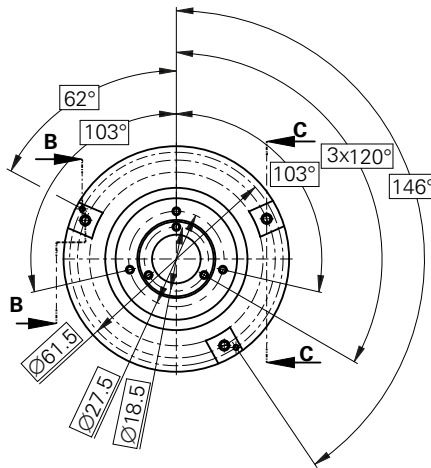
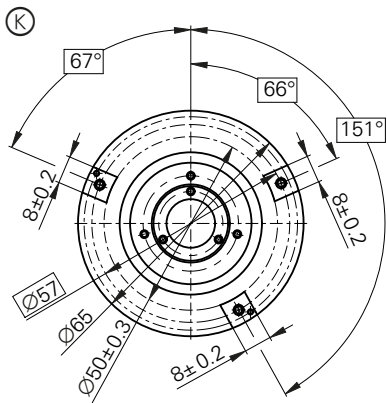
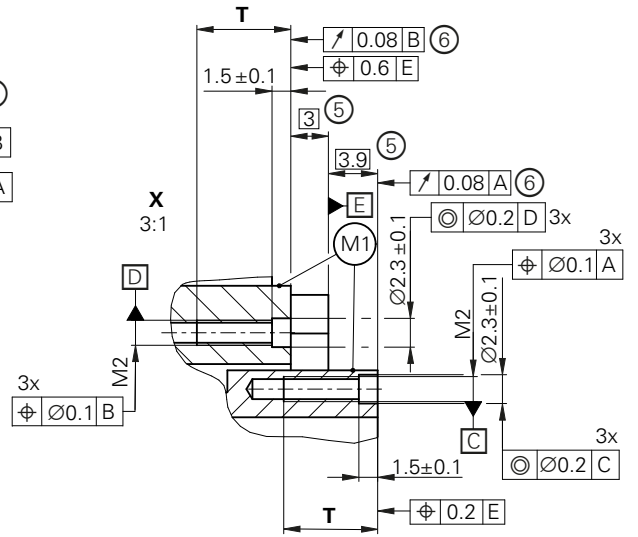
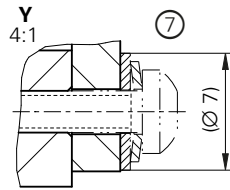
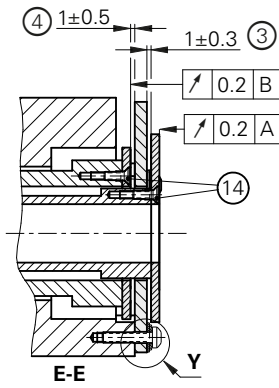
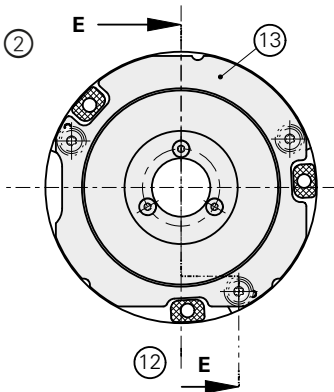

mm  
 Tolerancing ISO 8015  
 ISO 2768:1989-mH  
 ≤ 6 mm: ±0.2 mm

## Disk/hub assembly (for press-fitting)

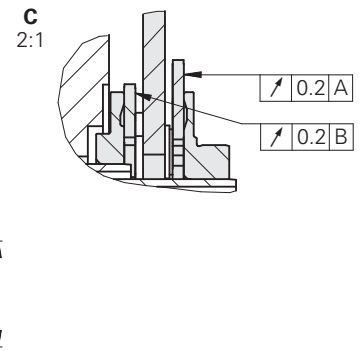
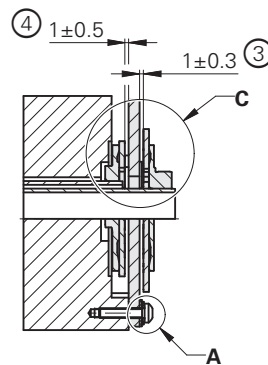
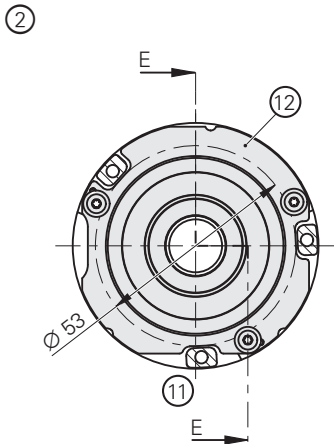
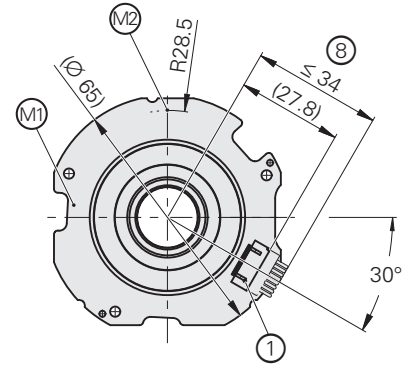
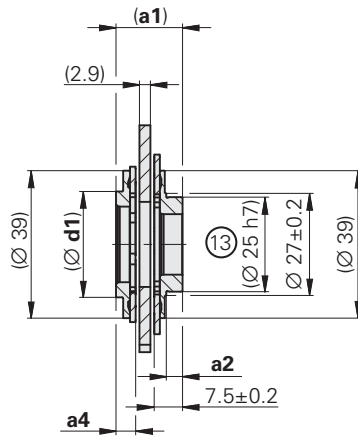
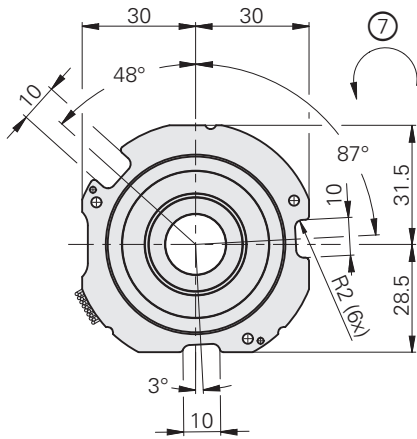

- ▣ = Bearing of Rotor A
- ▣ = Bearing of Rotor B
- ⊙ = Required mating dimensions
- M1 = Measuring point for operating temperature
- M2 = Vibration measuring point
- 1 = 15-pin PCB connector
- 2 = Shown with customer side
- 3 = Rotor A mounting dimension  
Tolerance includes compensation of mounting tolerances and thermal expansion
- 4 = Rotor B mounting dimension  
Tolerance includes compensation of mounting tolerances and thermal expansion
- 5 = Cylinder head screw  
Steel mating stator: 3x DIN EN ISO 4762 – M2.5x8 – 8.8 – MKL or DIN EN ISO 14583 – M2.5x12 – 8.8 – MKL\* with DIN 6796 – 2.5 – FSt spring washer and washer (ID1334909-01);  
**M<sub>d</sub>** = 0.7 Nm ± 0.05 Nm; note the orientation of the spring washer!  
Aluminum mating stator: 3x DIN EN ISO 4762 or DIN EN ISO 14583 – M2.5x12 – 8.8 – MKL\* with DIN 6796 – 2.5 – FSt spring washer and washer (ID1334909-01);  
**M<sub>d</sub>** = 0.7 Nm ± 0.05 Nm; note the orientation of the spring washer!
- 6 = Chamfer at start of thread is mandatory for material-bonding anti-rotation lock
- 7 = Direction of rotation of both shafts for ascending position values
- 8 = Ensure space for cable
- 9 = Rounded transition
- 10 = Ensure space for electronics
- 11 = Avoid collision with the scanning unit
- 12 = Gap for air and creepage distances > 1 mm
- 13 = Permissible forces and torques on the A hub (bearing)
  - Axial force ≤ 60 N
  - Radial force ≤ 60 N
  - Torque ≤ 0.5 Nm
- 14 = Material properties of customer shaft
  - Tensile strength ≥ 700 N/mm<sup>2</sup>
  - Yield point ≥ 490 N/mm<sup>2</sup>
  - CTE = 10 ppm/K – 12 ppm/K
- 15 = Free of burrs

	FOROA1: 06A, 06B	FOROA1: 07A, 07B
<b>a1</b>	17.6	18.1
<b>a2</b>	4.3	4
<b>a3</b>	7.3	7.8
<b>a4</b>	5.2±0.2	5.7±0.2
<b>d1</b>	28	33
<b>d2</b>	30	35
<b>d3</b>	20 <sup>0</sup> <sub>-0.02</sub>	25 <sup>0</sup> <sub>-0.02</sub>
<b>d4</b>	18	21
<b>d5</b>	14	18
<b>d6</b>	16 <sup>0</sup> <sub>-0.014</sub>	20 <sup>0</sup> <sub>-0.017</sub>

\*Instructions for use: Regarding the screw with material-bonding anti-rotation lock as per DIN 267-27, see *General mechanical information* in the *Rotary Encoders* brochure (not included in delivery!)

mm  
  
 Tolerancing ISO 8015  
 ISO 2768:1989-mH  
 ≤ 6 mm: ±0.2 mm



# General information

Specifications	KCI 120 Dplus	KBI 136 Dplus
<b>Interface</b>	EnDat 2.2	
Ordering designation	EnDat22	
Calculation time $t_{cal}$ Clock frequency	$\leq 5 \mu s$ $\leq 16 \text{ MHz}$	
<b>Electrical connection</b>	15-pin PCB connector (radial); cable length $\leq 10 \text{ m}$ <sup>1)</sup>	
Supply voltage	DC 3.6 V to 14 V (for both axes together)	$U_P$ : DC 3.6 V to 14 V (for both axes together) $U_{BAT}$ : DC 3.6 V to 5.25 V (backup battery)
Power consumption (max.) <sup>2)</sup>	At 3.6 V: $\leq 1.2 \text{ W}$ At 14 V: $\leq 1.4 \text{ W}$	
Current consumption (typical)	At 5 V: 200 mA (without load)	Normal operation at 5 V: 200 mA (without load) Backup battery: 200 $\mu\text{A}$ (rotating shaft) <sup>3)</sup> 20 $\mu\text{A}$ (at standstill)
Angular acceleration of rotors <sup>4)</sup>	$\leq 1 \cdot 10^5 \text{ rad/s}^2$ (circular scale of Encoder A, $\varnothing 22.5 \text{ mm}$ : $\leq 2 \cdot 10^4 \text{ rad/s}^2$ )	
<b>Vibration</b> 55 Hz to 2000 Hz <sup>5)</sup> <b>Shock</b> 6 ms	AE scanning unit: $\leq 400 \text{ m/s}^2$ ; rotors: $\leq 600 \text{ m/s}^2$ (EN 60068-2-6) $\leq 2000 \text{ m/s}^2$ (EN 60068-2-27)	
<b>Operating temperature</b>	-40 °C to 115 °C	
<b>Trigger threshold</b> Exceeded temperature error message	127 °C (measuring accuracy of the internal temperature sensor: $\pm 1 \text{ K}$ )	
<b>Relative humidity</b>	$\leq 93\%$ (40 °C/21 d as per EN 60068-2-78), without condensation	
<b>Protection</b> EN 60529	IP00 (read about insulation under <i>Electrical safety</i> in the <i>Interfaces of HEIDENHAIN Encoders</i> brochure)	
<b>Mass</b>	$\approx 0.065 \text{ kg}$ (scanning unit and disk/hub assemblies) $\approx 0.05 \text{ kg}$ (scanning unit with circular scales)	
<b>ID number</b>	ID 1348258-01 (AE scanning unit)	ID 1421550-01 (AE scanning unit)
	ID 1348267-01 (TKN: Encoder A, $\varnothing 20 \text{ mm}$ ) ID 1348267-02 (TKN: Encoder A, $\varnothing 16 \text{ mm}$ ) ID 1348268-01 (TKN: Encoder B, $\varnothing 25 \text{ mm}$ ) ID 1348268-02 (TKN: Encoder B, $\varnothing 20 \text{ mm}$ ) ID 1445825-01 (TK: Encoder A, $\varnothing 22.5 \text{ mm}$ ) ID 1445827-01 (TK: Encoder B, $\varnothing 14 \text{ mm}$ )	

<sup>1)</sup> See pin layout for encoder

<sup>2)</sup> See *General electrical information* in the *Interfaces of HEIDENHAIN Encoders* brochure, or visit [www.heidenhain.com](http://www.heidenhain.com)

<sup>3)</sup> The typical service life is 8 years when a recommended lithium thionyl chloride battery is used (3.6 V and 1200 mAh) and under the right conditions (two 10-hour shifts under normal operation; battery temperature: 25 °C; typical self-discharge)

<sup>4)</sup> With multiturn functionality in normal operation; maximum permissible acceleration in backup-battery mode upon request

<sup>5)</sup> *Scanning unit*: 10 Hz to 55 Hz, constant over 6.5 mm peak to peak

*Rotors*: 10 Hz to 55 Hz, constant over 10 mm peak to peak

# Position measurement

Specifications	KCI 120 <i>Dplus</i> singletum Output side (Encoder A)	KBI 136 <i>Dplus</i> multitum Output side (Encoder A)	KCI 120 <i>Dplus</i> singletum Motor side (Encoder B)
Shaft*	Hubs with an inside diameter of 20 mm or 16 mm Circular scale with inside hub diameter of 14 mm		Hubs with inside diameter of 25 mm or 20 mm Circular scale with inside hub diameter of 22.5 mm
Shaft speed	≤ 6000 rpm		≤ 15000 rpm
Moment of inertia of rotor	<i>TK of Encoder A:</i> $1.9 \cdot 10^{-6} \text{ kg} \cdot \text{m}^2$ <i>TK of Encoder B:</i> $9.7 \cdot 10^{-7} \text{ kg} \cdot \text{m}^2$ <i>TKN of Encoder A:</i> $5.5 \cdot 10^{-6} \text{ kg} \cdot \text{m}^2$ (without supporting ball bearing) <i>TKN of Encoder B:</i> $5.0 \cdot 10^{-6} \text{ kg} \cdot \text{m}^2$		
Axial motion <sup>1)</sup>	±0.3 mm		±0.5 mm
Position values per rev.	1 048 576 (20 bits)		524 288 (19 bits)
Revolutions	–	65 536 (16 bits)	–
<b>System accuracy</b>	±40"		±120"
Online compensation	No		Yes

\* Please select when ordering

<sup>1)</sup> Including thermal linear expansion and mounting tolerance

# Mounting

## Mounting and protection rating

### Mounting and protection rating

The KCI 120 *Dplus* / KBI 136 *Dplus* is mounted by screw-fastening the two circular scales or by press-fitting the two disk/hub assemblies, and by mounting the scanning unit. The disk/hub assemblies are press-fitted onto their respective shafts, or the circular scales are fastened to their respective shafts via three screws, and the scanning unit is mounted onto the mating surface via centering pins. The press-fitting process may be performed only once for each disk/hub assembly. For press-fitting, adhere to the material properties and conditions for the mating surfaces stated in the relevant documents for proper use. These requirements must be followed, even when new disk/hub assemblies are press-fitted onto a customer shaft that has already been used.

Once the lower limit of the press-fit force has been exceeded, the press-fit force being applied must remain within the specified range for the rest of the procedure until the final position is reached.

When the disk/hub assembly is press-fitted, force may be applied only to the intended surfaces by means of pressing stamps (see mounting instructions).

If a support bearing is used in conjunction with the hub of Encoder A, then the stated forces and the torque must not be exceeded:

Axial force  $\leq 60$  N  
Radial force  $\leq 60$  N  
Torque  $\leq 0.5$  Nm



### Further information:

Follow the measures for electromagnetic compatibility described in the *General electrical information* in the *Interfaces of HEIDENHAIN Encoders* brochure to ensure interference-free operation.

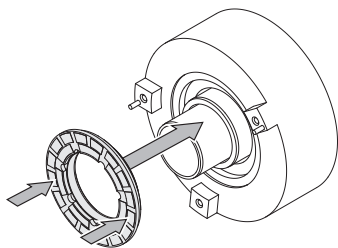

Press-fitting the disk/hub assembly (Encoder B)

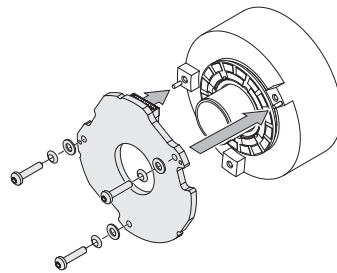

Mounting the scanning unit

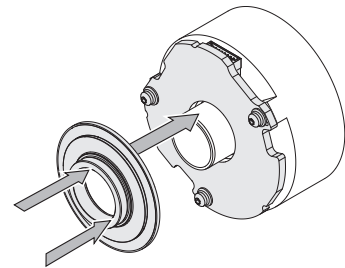

Press-fitting the disk/hub assembly (Encoder A)

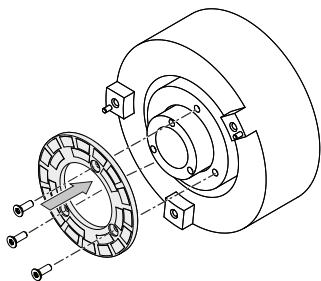

Screw-fastening the circular scale (Encoder B)

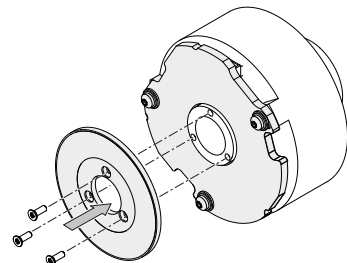

Screw-fastening the circular scale (Encoder A)

For the design of the fault exclusion, the following material properties and conditions for the mating surfaces are assumed.

	Mating shaft <sup>1)</sup>	Mating stator and mating shaft <sup>2)</sup>	
<b>Material</b>	S45C steel as per DIN 1.1191	Aluminum	Unalloyed hardened steel
<b>Tensile strength <math>R_m</math></b>	$\geq 700 \text{ N/mm}^2$	$\geq 220 \text{ N/mm}^2$	$\geq 600 \text{ N/mm}^2$
<b>Yield strength <math>R_{p0.2}</math> or yield point <math>R_e</math></b>	$\geq 490 \text{ N/mm}^2$	Not relevant	$\geq 400 \text{ N/mm}^2$
<b>Shear strength <math>\tau_a</math></b>	$\geq 390 \text{ N/mm}^2$	$\geq 130 \text{ N/mm}^2$	$\geq 390 \text{ N/mm}^2$
<b>Interface pressure <math>p_G</math></b>	$\geq 660 \text{ N/mm}^2$	$\geq 250 \text{ N/mm}^2$	$\geq 660 \text{ N/mm}^2$
<b>Modulus of elasticity <math>E</math></b> (at 20 °C)	210 kN/mm <sup>2</sup>	70 kN/mm <sup>2</sup> to 75 kN/mm <sup>2</sup>	200 kN/mm <sup>2</sup> to 215 kN/mm <sup>2</sup>
<b>Coefficient of thermal expansion <math>\alpha_{\text{therm}}</math></b> (at 20 °C)	$10 \cdot 10^{-6} \text{K}^{-1}$ to $12 \cdot 10^{-6} \text{K}^{-1}$	$\leq 25 \cdot 10^{-6} \text{K}^{-1}$	$10 \cdot 10^{-6} \text{K}^{-1}$ to $17 \cdot 10^{-6} \text{K}^{-1}$
<b>Surface roughness <math>R_z</math></b>	$\leq 6.3 \dots 16 \mu\text{m}$		
<b>Friction values</b>	Lubrication at the joint surfaces is recommended.	Mounting surfaces must be clean and free of grease. Use screws and washers in their condition as delivered.	
<b>Tightening procedure</b>	–	Use a signal-emitting torque wrench as per DIN EN ISO 6789; accuracy of $\pm 6 \%$	
<b>Mounting temperature</b>	15 °C to 35 °C		

<sup>1)</sup> For mounting of TKN (press-fitting)

<sup>2)</sup> For mounting of TK (screw-fastening)

## Mounting accessories

### Screws, spring washers and washer

Screws (mounting screws) are not included in delivery.  
The washer can be ordered separately.

KCI 120 Dplus KBI 136 Dplus	Mating shaft, mating stator		
<b>Screw</b> for fastening the scanning unit	Steel Aluminum	DIN EN ISO 4762/14583- <b>M2.5x8</b> -8.8- <b>MKL</b> <sup>1)</sup> DIN EN ISO 4762/14583- <b>M2.5x12</b> -8.8- <b>MKL</b> <sup>1)</sup>	–
<b>Fastening-screw</b> for circular scale	Steel Aluminum	ISO 14581- <b>M2x6</b> -A2-070 <sup>2)</sup> ISO 14581- <b>M2x8</b> -A2-070 <sup>2)</sup>	–
<b>Spring washers</b>	–	DIN 6796 – 2.5 – FSt.	–
<b>Washer</b>	–	–	ID 1334909-01

<sup>1)</sup> With coating for material-bonding anti-rotation lock

(for information on usage, see the *Encoders for Servo Drives* brochure)

<sup>2)</sup> Screw without material-bonding anti-rotation lock; a material-bonding anti-rotation lock of at least medium strength must be used

Instructions for use: use screws with material bonding anti-rotation lock as per DIN 26727 (see the *General mechanical information* in the *Rotary Encoders* brochure). Fastening-screws and spring washers are not included in delivery.

For more mounting information and mounting aids, see the Mounting Instructions and the *Encoders for Servo Drives* brochure. The mounting quality can be checked with the PWM 21 and the ATS software (see document ID 1082415).

### Mounting aid

To avoid damage to the cable, use the mounting aid to disconnect the cable assembly. Apply pulling force solely to the connector of the cable assembly and not to the wires.

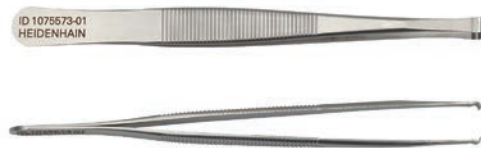

ID 1075573-01

# Integrated temperature evaluation

Each axis of these rotary encoders features an internal temperature sensor integrated into the encoder electronics. The digitized temperature value is transmitted purely serially via the EnDat protocol.

Regarding the internal temperature sensor, the rotary encoder supports the two-stage cascaded signaling of a temperature exceedance. This consists of an EnDat warning and an EnDat error message.

In accordance with the EnDat specification, an EnDat warning (EnDat memory area "Operating status," word 1 "Warnings," bit 2<sup>1</sup> "Temperature exceeded") is output when the warning threshold for the temperature exceedance of the internal temperature sensor is reached. This warning threshold for the internal temperature sensor is stored in the EnDat memory area "Operating parameters," word 6 "Trigger threshold warning bit for excessive temperature" of each axis, and can be individually adjusted.

A device-specific default value is saved here before the encoder is shipped. The temperature measured by the internal temperature sensor is higher by a device-specific and application-specific amount than the temperature at the measuring point as shown in the dimension drawing.

Each axis of the rotary encoders features a further, albeit non-adjustable trigger threshold for the "Temperature exceeded" EnDat error message of the internal temperature sensor. When this is reached, an EnDat error message is output (EnDat memory area "Operating status," word 0 "Error messages," bit 2<sup>2</sup> "Position" and in additional data 2 "Operating status error sources," bit 2<sup>6</sup> "Temperature exceeded"). This trigger threshold may vary depending on the encoder and is stated in the specifications.

HEIDENHAIN recommends adjusting the warning threshold based on the application such that this threshold is sufficiently below the trigger threshold for the "Temperature exceeded" EnDat error message. Compliance with the temperature at the measuring point is required for adherence to the encoder's intended and proper use.

## Electrical resistance

Check the electrical resistance between the customer-side stator and both customer-side shafts. Nominal value: < 1 ohm

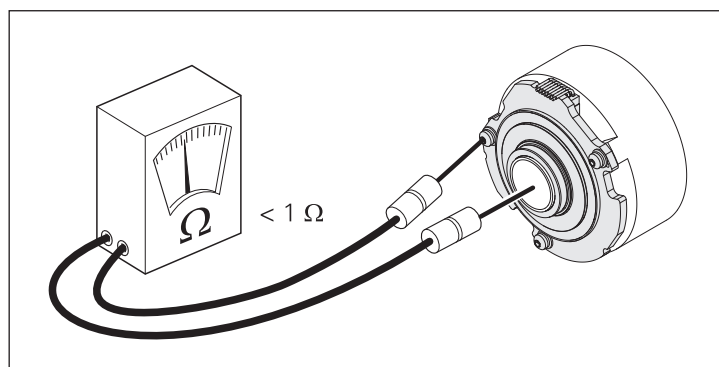

# Testing and inspection devices, and diagnostics

HEIDENHAIN encoders provide all of the information needed for setup, monitoring and diagnostics. The type of information available depends on whether the encoder is incremental or absolute and on which interface is being used.

Absolute encoders employ serial data transmission. The signals are extensively monitored within the encoder. The monitoring results (particularly valuation numbers) can be transmitted to the downstream electronics along with the position values via the serial interface (**digital diagnostic interface**). The following information is available:

- Error message: position value is not reliable
- Warning: an internal functional limit of the encoder has been reached
- Valuation numbers:
  - Detailed information about the encoder's function reserve
  - Identical scaling for all HEIDENHAIN encoders
  - Cyclic reading capability

This enables the downstream electronics to evaluate the current status of the encoder with little effort, even in closed-loop mode.

For the analysis of these encoders, HEIDENHAIN offers the appropriate PWM inspection devices and PWT testing units. Based on how these devices are integrated, a distinction is made between two types of diagnostics:

- Encoder diagnostics: the encoder is connected directly to the testing or inspection device, thereby enabling a detailed analysis of encoder functions.

- Monitoring mode: the PWM inspection device is inserted within the closed control loop (via suitable testing adapters as needed). This enables real-time diagnosis of the machine or equipment during operation. The available functions depend on the interface.

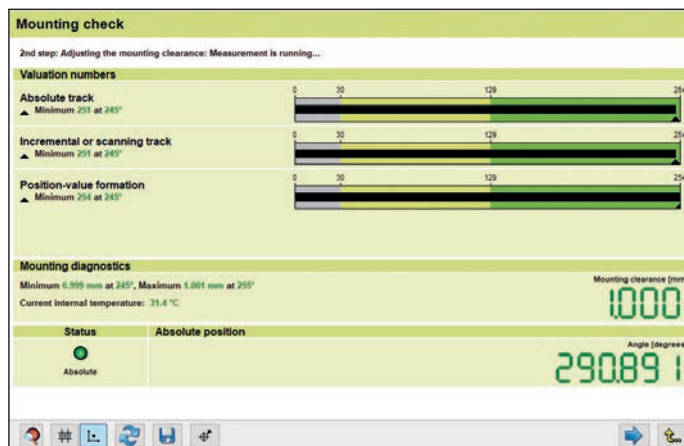

Checking the mounting accuracy with the PWM 21 and ATS

## PWM 21

The PWM 21 phase-angle measuring unit, in conjunction with the included ATS adjusting and testing software, serves as an adjusting and testing package for the diagnosis and adjustment of HEIDENHAIN encoders.



For more information, see the *PWM 21, ATS Software* Product Information document.

	PWM 21
<b>Encoder input</b>	<ul style="list-style-type: none"> <li>• EnDat 2.1, EnDat 2.2 or EnDat 3 (absolute value with or without incremental signals)</li> <li>• DRIVE-CLiQ</li> <li>• Fanuc Serial Interface</li> <li>• Mitsubishi high speed interface</li> <li>• Yaskawa Serial Interface</li> <li>• Panasonic serial interface</li> <li>• SSI</li> <li>• 1 V<sub>PP</sub>/TTL/11 μA<sub>PP</sub></li> <li>• HTL (via signal adapter)</li> </ul>
<b>Interface</b>	USB 2.0
<b>Supply voltage</b>	AC 100 V to 240 V or DC 24 V
<b>Dimensions</b>	258 mm × 154 mm × 55 mm

DRIVE-CLiQ is a registered trademark of Siemens AG.

# Electrical connection

Connecting a special testing cable to the PWM 21 diagnostic and inspection unit establishes a connection with Encoder A (output side). Encoder B (motor side) is connected via a different special testing cable.

HEIDENHAIN offers two testing cables for this purpose. As a result, either a testing cable for the output-side encoder or a testing cable for the motor-side encoder can be connected to the PWM 21 as needed.

## Pin layout of the testing cables

Testing cables for connecting to Encoder A: 1311046-xx (contained in the testing cable package (ID 1311061-xx))

15-pin PCB connector					Serial data transmission (Encoder A)			
Supply voltage					Serial data transmission (Encoder A)			
15	14	12	13	11	7	8	9	10
<b>KCI 120 Dplus</b>	0V <sup>1)</sup>	Sensor <sup>1)</sup> 0V	U <sub>P</sub> <sup>1)</sup>	Sensor <sup>1)</sup> U <sub>P</sub>	DATA A	$\overline{\text{DATA A}}$	CLOCK A	$\overline{\text{CLOCK A}}$
<b>KBI 136 Dplus</b>	U <sub>P</sub>	U <sub>BAT</sub>	0V <sup>1)</sup>	0V <sub>BAT</sub> <sup>1)</sup>	DATA A	$\overline{\text{DATA A}}$	CLOCK A	$\overline{\text{CLOCK A}}$
	White/Green	White	Brown/Green	Blue	Gray	Pink	Violet	Yellow

U<sub>P</sub> = Power supply

Vacant pins or wires must not be used!

<sup>1)</sup> Connected inside the encoder

Testing cables for connecting to Encoder B: 1311047-xx (contained in the testing cable package (ID 1311061-xx))

15-pin PCB connector					Serial data transmission (Encoder B)			
Supply voltage					Serial data transmission (Encoder B)			
15	14	12	13	11	1	2	3	4
<b>KCI 120 Dplus</b>	0V <sup>1)</sup>	Sensor <sup>1)</sup> 0V	U <sub>P</sub> <sup>1)</sup>	Sensor <sup>1)</sup> U <sub>P</sub>	DATA B	$\overline{\text{DATA B}}$	CLOCK B	$\overline{\text{CLOCK B}}$
<b>KBI 136 Dplus</b>	U <sub>P</sub>	U <sub>BAT</sub>	0V <sup>1)</sup>	0V <sub>BAT</sub> <sup>1)</sup>	DATA B	$\overline{\text{DATA B}}$	CLOCK B	$\overline{\text{CLOCK B}}$
	White/Green	White	Brown/Green	Blue	Gray	Pink	Violet	Yellow

U<sub>P</sub> = Power supply

Vacant pins or wires must not be used!

<sup>1)</sup> Connected inside the encoder

## Pin layout

15-pin PCB connector												
	Supply voltage				Serial data transmission (Encoder A)				Serial data transmission (Encoder B)			
 15	14	12	13	11	7	8	9	10	1	2	3	4
<b>KCI 120 Dplus</b>	0V <sup>1)</sup>	Sensor <sup>1)</sup> 0V	U <sub>P</sub> <sup>1)</sup>	Sensor <sup>1)</sup> U <sub>P</sub>	DATA A	DATA A	CLOCK A	CLOCK A	DATA B	DATA B	CLOCK B	CLOCK B
<b>KBI 136 Dplus</b>	U <sub>P</sub>	U <sub>BAT</sub>	0V <sup>1)</sup>	0V <sub>BAT</sub> <sup>1)</sup>	DATA A	DATA A	CLOCK A	CLOCK A	DATA B	DATA B	CLOCK B	CLOCK B

U<sub>P</sub> = Power supply

Vacant pins or wires must not be used!

<sup>1)</sup> Connected inside the encoder

The subsequent electronics must have a common ground reference!

Cable length > 0.5 m:

To prevent crosstalk, the two EnDat interfaces must be separately shielded from each other. The cable sold by the meter with ID 1347450-xx (PUR, Ø 3.7 mm) can be used for this. Two cables must be attached to the PCB connector in order to transmit the EnDat signals separately. Only one cable is used for the power supply.

When using the cable sold by the meter with ID 1347450-xx, comply with the general information in the *Cables and Connectors* brochure; use of the cables at temperatures of up to 100 °C is possible, provided that the exposure to hydrolysis and harmful media is low.

Cable length ≤ 0.5 m:

When single wires with up to a maximum length of 0.5 m are used, each data and clock wire combination must be implemented as a twisted wire pair in order to avoid coupled interferences. As an alternative, the cable with ID 605090-51 (EPG, Ø 4.5 mm) and a length of 0.3 m can be used. The general information in the *Cables and Connectors* brochure must be taken into account.

# HEIDENHAIN

**DR. JOHANNES HEIDENHAIN GmbH**

Dr.-Johannes-Heidenhain-Straße 5

**83301 Traunreut, Germany**

☎ +49 8669 31-0

FAX +49 8669 32-5061

info@heidenhain.de

[www.heidenhain.com](http://www.heidenhain.com)

This Product Information document supersedes all previous editions, which thereby become invalid. The basis for ordering from HEIDENHAIN is always the Product Information document edition valid when the order is placed.



### Further information:

Comply with the requirements described in the following documents to ensure correct and intended operation:

- KCI 120 Dplus, KBI 136 Dplus Operating Instructions 1364851-xx
- TK KCI 120 Dplus, KBI 136 Dplus AE04 Operating Instructions 1432069-xx