



HEIDENHAIN



**Functional
Safety**

Product Information

KCI 120

KBI 136

Absolute Inductive Rotary
Encoders without Integral
Bearing

With additional measures:
suitable for safety-related
applications with up to SIL 3

EnDat 2.2

03/2023

KCI 120, KBI 136

Rotary encoders for absolute position values

- Robust inductive scanning principle
- Consisting of a scanning unit and a rotor unit

Functional Safety

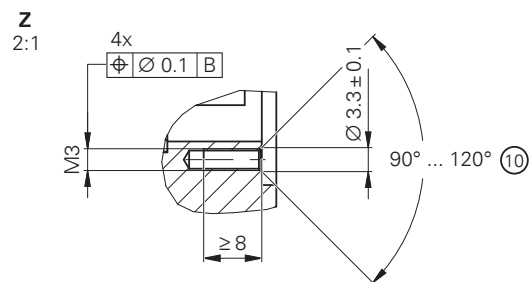
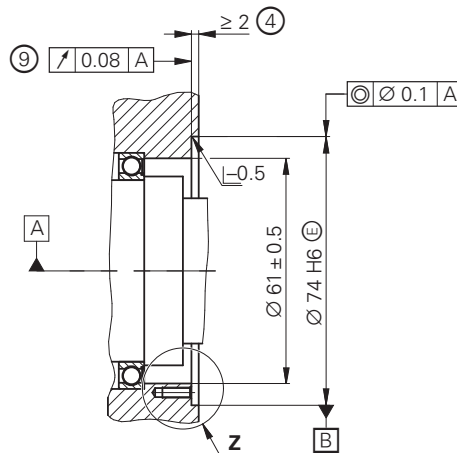
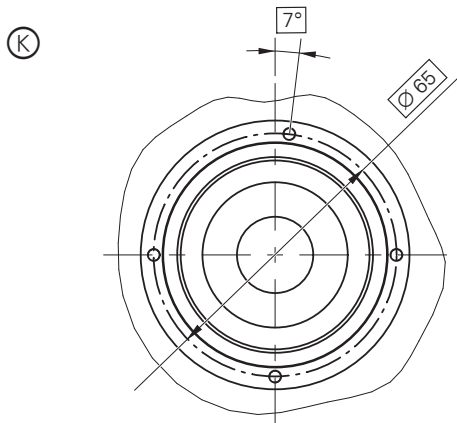
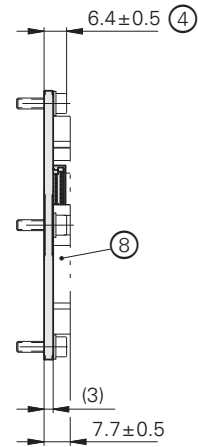
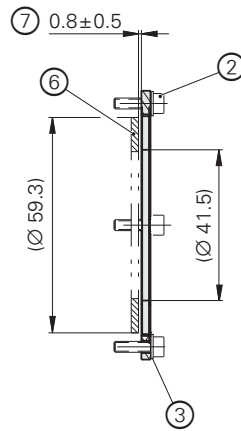
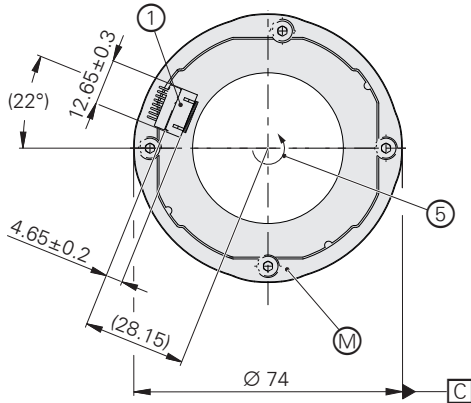

- ▣ = Bearing of mating shaft
- ⊙ = Required mating dimensions
- ⊗ = Measuring point for operating temperature and vibration
- 1 = 15-pin PCB connector
- 2 = Cylinder head screw:
M3x10 DIN EN ISO 4762-8.8-MKL*; ID 202264-87; Md = 1 Nm ± 0.06 Nm
- 3 = Washer: ISO 7089-3-200HV-A2
- 4 = Ensure space for cable
- 5 = Direction of shaft rotation for ascending position values
- 6 = TK/TKN, separate, with different versions possible; for mounting, see the respective dimension drawing
- 7 = Mounting clearance between circular scale surface and flange surface;
compensation of mounting tolerances and thermal expansion;
dynamic motion permitted over entire range
(with use of ATS software for mounting inspection, the display value for the mounting clearance is shown as 1 mm)
- 8 = Ensure space for electronics; see also the mating dimensions model
- 9 = Flange surface; ensure full-surface contact!
- 10 = Chamfer at start of thread is obligatory for material bonding anti-rotation lock

* Instructions for use: use screw with material bonding anti-rotation lock as per DIN 267-27 (not included in delivery); see *General mechanical information* in the *Encoders for Servo Drives* brochure

mm

 Tolerancing ISO 8015
 ISO 2768:1989-mH
 ≤ 6 mm: ±0.2 mm

Rotor fastening via three axial countersunk head screws

| | TK | D1 | D2 | d1 |
|------|--------|----------|--------|--------|
| Ø 30 | Ø 36 | ≤ Ø 29.9 | ≥ Ø 40 | Ø 30.5 |
| Ø 40 | Ø 45.5 | ≤ Ø 39.9 | ≥ Ø 50 | Ø 40.5 |

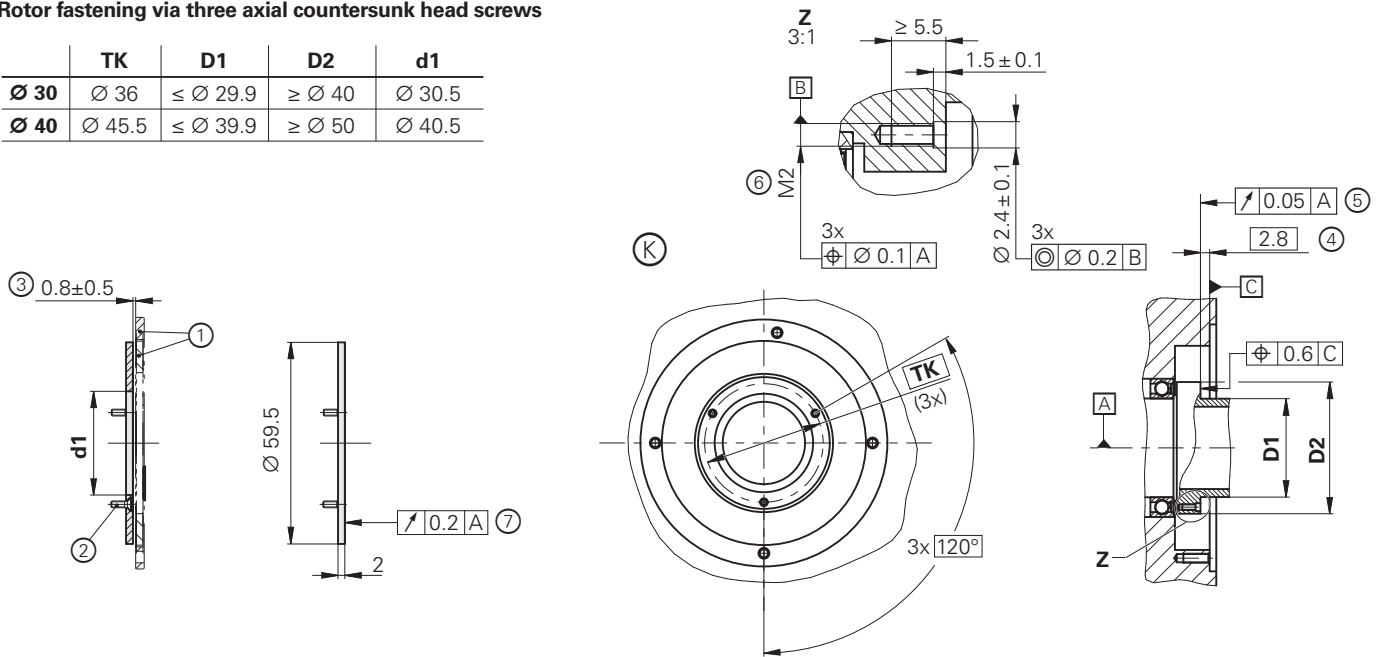

Rotor fastening via press-fitted hub

| | d1 | d2 | D1 | D2 | D3 |
|------|------|--------|--------------------|----------|----------|
| Ø 30 | Ø 30 | ≤ Ø 25 | Ø 30h6 (circled 6) | Ø 48±0.3 | Ø 42±0.3 |
| Ø 40 | Ø 40 | ≤ Ø 35 | Ø 40h6 (circled 6) | Ø 57±0.3 | Ø 52±0.3 |

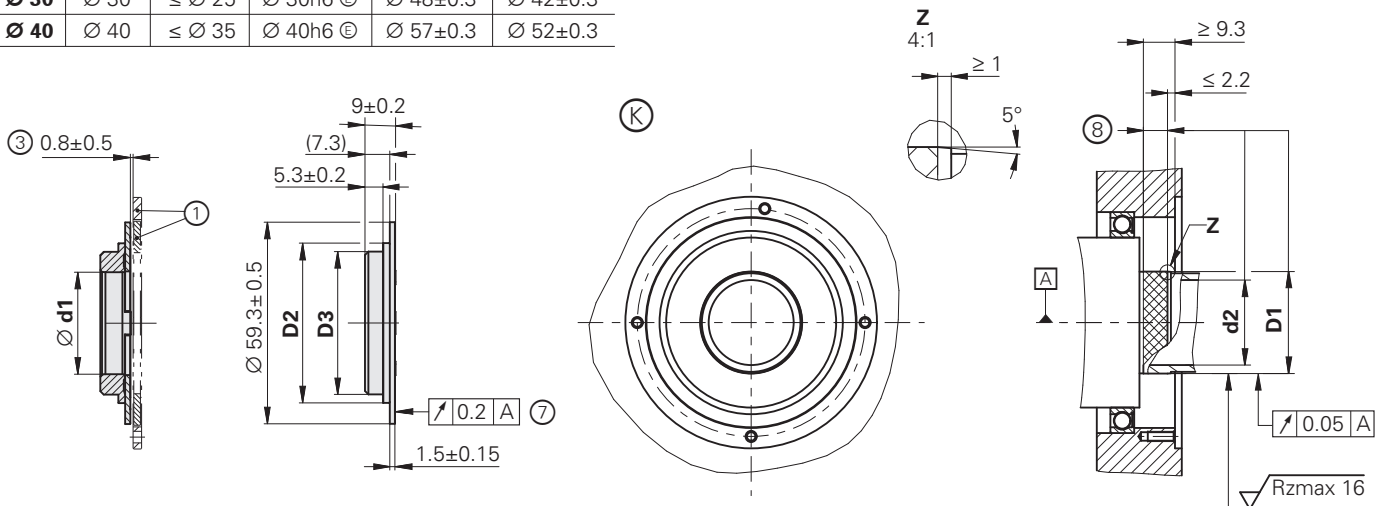

- ▣ = Bearing of mating shaft
- ⊙ = Required mating dimensions
- 1 = Scanning unit, separate; different versions possible; for mounting, see the respective dimension drawing
- 2 = Countersunk head screw:
M2x6 DIN EN ISO 14581-A2-70; ID 576131-42; 0.25 Nm ±0.015 Nm; protrusion of screw head not permitted
- 3 = Mounting clearance between circular scale surface and flange surface of scanning unit; dynamic motion permitted over entire range (with use of ATS software for mounting inspection, the display value for the mounting clearance is shown as 1 mm)
- 4 = Distance between scanning unit flange surface and circular scale surface
- 5 = Circular scale surface
- 6 = Use material bonding anti-rotation lock (at least medium strength)*
- 7 = On the fine track (Ø 50.8 mm to Ø 58.8 mm), after being screw-fastened
- 8 = For press-fitting parameters, see the Mounting Instructions

* Instructions for use: use screw with material bonding anti-rotation lock as per DIN 267-27 (not included in delivery); see *General mechanical information* in the *Encoders for Servo Drives* brochure

mm

 Tolerancing ISO 8015
 ISO 2768:1989-mH
 ≤ 6 mm: ±0.2 mm

| Specifications | KCI 120 singleturn | KBI 136 multiturn |
|---|---|---|
| Functional safety for applications with up to | As a single-encoder system for monitoring functions and control-loop functions: <ul style="list-style-type: none"> • SIL 2, as per EN 61508 (further basis for testing: IEC 61800-5-3) • Category 3, PL d, in accordance with EN ISO 13849-1:2015 With additional measures as per document 1000344, suitable for safety-related applications with up to SIL 3 or Category 4, PL e Safe in the singleturn range | |
| PFH | $SIL\ 2: \leq 15 \cdot 10^{-9}$ (probability of dangerous failure per hour) $SIL\ 3: \leq 2 \cdot 10^{-9}$ | |
| Safe position ¹⁾ | <i>Encoder:</i> $\pm 0.88^\circ$ (safety-related measuring step $SM = 0.35^\circ$) <i>Mechanical coupling:</i> 0° (fault exclusion for the loosening of the shaft coupling and stator coupling, designed for accelerations on the stator: $\leq 400\text{ m/s}^2$; on the rotor: $\leq 600\text{ m/s}^2$) | |
| Interface | EnDat 2.2 | |
| Ordering designation | EnDat22 | |
| Position values per revolution | 1 048 576 (20 bits) | |
| Revolutions | – | 65 563 (16 bits) |
| Calculation time t_{cal} Clock frequency | $\leq 5\ \mu\text{s}$ $\leq 16\text{ MHz}$ | |
| System accuracy | $\pm 40''$ | |
| Electrical connection | 15-pin PCB connector (with connection for external temperature sensor) | |
| Cable length | $\leq 100\text{ m}$ (see the EnDat description in the <i>Interfaces of HEIDENHAIN Encoders</i> brochure) | |
| Supply voltage | DC 3.6 V to 14 V | <i>Rotary encoder</i> U_P : DC 3.6 V to 14 V <i>Backup battery</i> U_{Bat} : DC 3.6 V to 5.25 V |
| Power consumption ²⁾ (max.) | <i>At 3.6 V:</i> $\leq 650\text{ mW}$ <i>At 14 V:</i> $\leq 700\text{ mW}$ | |
| Current consumption (typical) | <i>At 5 V:</i> 115 mA | <i>Normal operation at 5 V:</i> 105 mA (without load) <i>Backup battery:</i> 200 μA (rotating shaft) ³⁾ 20 μA (at standstill) |
| ID number | AE KCI 120 scanning head 1353137-01 Circular scale (screw-fastened version) 1353144-01 (30 mm) 1353142-01 (40 mm) Disk/hub assembly (press-fitted version) 1353143-01 (30 mm) 1353141-01 (40 mm) | AE KBI 136 scanning head 1353139-01 Circular scale (screw-fastened version) 1353144-01 (30 mm) 1353142-01 (40 mm) Disk/hub assembly (press-fitted version) 1353143-01 (30 mm) 1353141-01 (40 mm) |

¹⁾ Further tolerances may arise in the downstream electronics after position value comparison (contact mfr.)

²⁾ See *General electrical information* in the *Interfaces of HEIDENHAIN Encoders* brochure, or visit www.heidenhain.com

³⁾ At $T = 25\text{ }^\circ\text{C}$; $U_{Bat} = 3.6\text{ V}$

| Specifications | KCI 120 singleturn | KBI 136 multiturn |
|--|--|-------------------|
| Rotor* | 30 mm or 40 mm disk/hub assembly (press-fit version) 36 mm or 45.5 mm bolt circle diameter (screw-fastened version) | |
| Shaft speed | ≤ 10000 rpm | |
| Moment of inertia | <i>Disk/hub assembly:</i> 40 mm hollow shaft: $32.2 \cdot 10^{-6} \text{ kgm}^2$; 30 mm hollow shaft: $18 \cdot 10^{-6} \text{ kgm}^2$; <i>Circular scale:</i> 40 mm hollow shaft: $7 \cdot 10^{-6} \text{ kgm}^2$; 30 mm hollow shaft: $4.43 \cdot 10^{-6} \text{ kgm}^2$ | |
| Angular acceleration of rotor ¹⁾ | ≤ $1 \cdot 10^5 \text{ rad/s}^2$ | |
| Axial motion of measured shaft | ≤ ±0.5 mm | |
| Vibration 55 Hz to 2000 Hz ²⁾ Shock 6 ms | <i>Stator:</i> ≤ 400 m/s^2 ; <i>rotor:</i> ≤ 600 m/s^2 (EN 60068-2-6) ≤ 2000 m/s^2 (EN 60068-2-27) | |
| Operating temperature | −40 °C to 115 °C | |
| Relative humidity | ≤ 93% (40 °C/21 d as per EN 60068-2-78), condensation excluded | |
| Protection rating EN 60529 | IP00 | |
| Mass | ≈ 0.09 kg (scanning unit + disk/hub assembly) ≈ 0.04 kg (scanning unit + circular scale) | |

* Please select when ordering

¹⁾ With multiturn functionality in normal operation; maximum permissible acceleration in backup-battery mode upon request

²⁾ 10 Hz to 55 Hz, 4.9 mm constant peak to peak

Installation

The KCI 120/KBI 136 is mounted either via screw-fastening of the circular scale or through press-fitting of the disk/hub assembly, followed by mounting of the scanning unit. The disk/hub assembly is thereby either press-fitted onto the shaft, or the circular scale is screw-fastened to the given shaft with three screws. The scanning unit is aligned and mounted via four holes on the customer's mounting surface.

The press-fitting process may be performed only once for each disk/hub assembly. For press-fitting, adhere to the material properties and conditions for the mating surface stated in the relevant documents for proper use. These requirements must be followed, even when new disk/hub assemblies are press-

fitted onto customer shafts that have already been used. The maximum pressing force must not be exceeded throughout the press-fitting procedure. Starting at one millimeter before reaching the final position, the pressing force must not fall below the minimum pressing force.

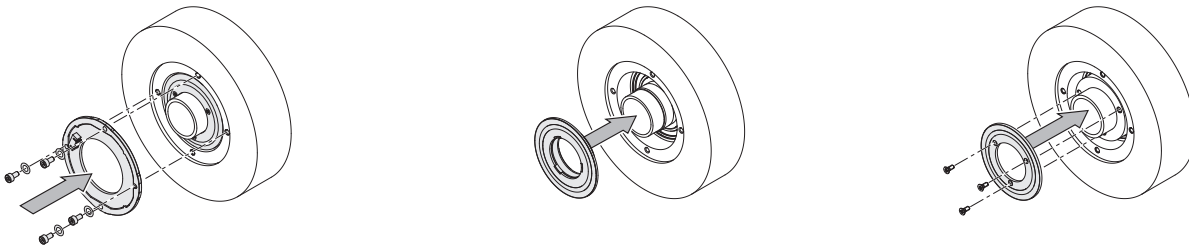

The following material properties and conditions must be complied with for the customer-side mounting design:

| | Mating stator | Mating shaft |
|---|--|--|
| Material | Aluminum | Steel |
| Tensile strength R_m | $\geq 220 \text{ N/mm}^2$ | $\geq 600 \text{ N/mm}^2$ |
| Yield strength $R_{p0.2}$ or yield point R_e | – | $\geq 400 \text{ N/mm}^2$ |
| Shear strength τ_a | 130 N/mm^2 | $\geq 390 \text{ N/mm}^2$ |
| Interface pressure P_G | $\geq 250 \text{ N/mm}^2$ | $\geq 660 \text{ N/mm}^2$ |
| Modulus of elasticity E (at 20 °C) | 70 kN/mm^2 to 75 kN/mm^2 | 200 kN/mm^2 to 215 kN/mm^2 |
| Coefficient of thermal expansion α_{therm} (at 20 °C) | $\leq 25 \cdot 10^{-6} \text{ K}^{-1}$ | <i>Screw-fastened version:</i> $10 \cdot 10^{-6} \text{ K}^{-1}$ to $17 \cdot 10^{-6} \text{ K}^{-1}$ <i>Press-fitted version:</i> $10 \cdot 10^{-6} \text{ K}^{-1}$ to $12 \cdot 10^{-6} \text{ K}^{-1}$ |
| Surface roughness R_z | $\leq 16 \mu\text{m}$ | |
| Friction values | Mounting surfaces must be clean and free of grease. Use screws and washers from HEIDENHAIN in their condition as delivered. | |
| Tightening procedure | Use a signal-emitting torque wrench in accordance with DIN EN ISO 6789, with an accuracy of $\pm 6\%$ | |
| Mounting temperature | 15 °C to 35 °C | |

Mounting accessories

Screws

Screws (fastening screws) are not included in delivery; the M3x10 screws with material bonding anti-rotation lock can be ordered separately.

| KCI 120 KBI 136 | Screws | Quantity | |
|--|--|--------------|-----------|
| Screw for fastening the scanning unit | ISO 4762- M3x10-8.8-MKL ¹⁾ | ID 202264-87 | 10 or 100 |
| Washers for fastening the scanning unit | ISO 7089-3-200HV-A2 | – | – |
| Fastening screw for circular scale | ISO 14581- M2x6-A2-70 ²⁾ | – | – |

¹⁾ With coating for material bonding anti-rotation lock (for information on use, see the *Encoders for Servo Drives* brochure)

²⁾ Without anti-rotation lock; use at least a medium-strength material bonding anti-rotation lock

Mounting aid

To avoid damage to the cable, use the mounting aid to connect and disconnect the cable assembly. Apply pulling force only to the connector of the cable assembly and not to the wires.

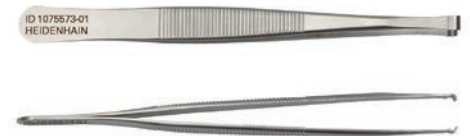

ID 1075573-01

For more mounting information and mounting aids, see the Mounting Instructions and the *Encoders for Servo Drives* brochure. The mounting quality can be inspected with the PWM 21 and the ATS software (see Document 1082415).



Electrical connection

Cables

| Output cables inside the motor housing with TPE single wires ($8 \times 0.16 \text{ mm}^2$) and net sleeve without shield | | |
|---|--|-----------------------------|
| With 15-pin PCB connector and 8-pin M12 straight flange socket (male) with TPE single wires for temperature sensor ($2 \times 0.16 \text{ mm}^2$) |  | ID 1119952-xx |
| 15-pin PCB connector and 8-pin M12 straight flange socket (male) |  | ID 804201-xx |
| With 15-pin PCB connector with TPE single wires for temperature sensor ($2 \times 0.16 \text{ mm}^2$) and stripped cable end |  | ID 1119958-xx ¹⁾ |

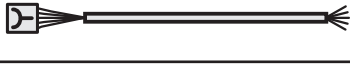
| Output cable inside the motor housing with TPE single wires ($8 \times 0.16 \text{ mm}^2$) and heat shrink tubing without a shield | | |
|---|--|----------------------------|
| 15-pin PCB connector and stripped cable end |  | ID 640055-xx ¹⁾ |

| Output cable for HMC 6: $\varnothing 3.7 \text{ mm EPG } 1 \times (4 \times 0.06 \text{ mm}^2) + 4 \times 0.06 \text{ mm}^2$ | | |
|--|--|---------------|
| With 15-pin PCB connector and contact insert for 6-pin HMC 6 hybrid connector (male) with TPE single wires for temperature sensor ($2 \times 0.16 \text{ mm}^2$), with cable clamp for shield connection |  | ID 1072652-xx |









¹⁾ Connecting elements must be suitable for the maximum clock frequency used

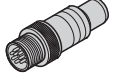

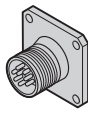
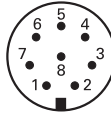
More information:

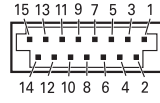
For connecting cables and adapter cables, see the *Cables and Connectors* brochure.

Pin layout for KCI 120







| 8-pin M12 coupling or flange socket | | | | | 15-pin PCB connector | | | | | |
|---|---|---|---|---|---|---|--------------|--------------|---------------|-----------|
|  |  |  |  |  |  |  | | | | |
| | Power supply | | | | Serial data transmission | | | | Other signals | |
|  | 8 | 2 | 5 | 1 | 3 | 4 | 7 | 6 | / | / |
|  | 13 | 11 | 14 | 12 | 7 | 8 | 9 | 10 | 5 | 6 |
| | U_P | Sensor U _P | 0V | Sensor 0V | DATA | DATA | CLOCK | CLOCK | T+ | T- |
|  | Brown/ Green | Blue | White/ Green | White | Gray | Pink | Violet | Yellow | Brown | Green |

Cable shield connected with housing; **U_P** = Power supply; **T** = Temperature

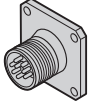
Sensor: The sense line is connected in the encoder with the corresponding power line.

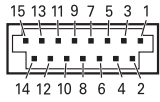
Vacant pins or wires must not be used!

Pin layout for KBI 136

| 8-pin M12 flange socket | | | | | 15-pin PCB connector | | | | | |
|---|---|---|------------------------|--------------------------------------|---|--|--------------|--------------|---------------|-----------|
|  |  |  | | |  |  | | | | |
| | Power supply | | | | Serial data transmission | | | | Other signals | |
|  | 13 | 11 | 14 | 12 | 7 | 8 | 9 | 10 | 5 | 6 |
|  | 8 | 2 | 5 | 1 | 3 | 4 | 7 | 6 | / | / |
| | U_P | U_{BAT} | 0V¹⁾ | 0V_{BAT}¹⁾ | DATA | DATA | CLOCK | CLOCK | T+ | T- |
|  | Brown/ Green | Blue | White/ Green | White | Gray | Pink | Violet | Yellow | Brown | Green |

U_P = Power supply; **U_{BAT}** = External buffer battery (false polarity can result in damage to the encoder)

Vacant pins or wires must not be used!

¹⁾ Connected inside encoder

HEIDENHAIN

DR. JOHANNES HEIDENHAIN GmbH

Dr.-Johannes-Heidenhain-Straße 5

83301 Traunreut, Germany

☎ +49 8669 31-0

FAX +49 8669 32-5061

info@heidenhain.de

www.heidenhain.com

This Product Information document supersedes all previous editions, which thereby become invalid. The basis for ordering from HEIDENHAIN is always the Product Information document edition valid when the order is placed.



More information:

Comply with the requirements described in the following documents to ensure correct and intended operation:

- Operating Instructions: AE KCI 120, KBI 136 1395973-xx
- Operating Instructions: TK/TKN KCI 120, KBI 136 1388511-xx