

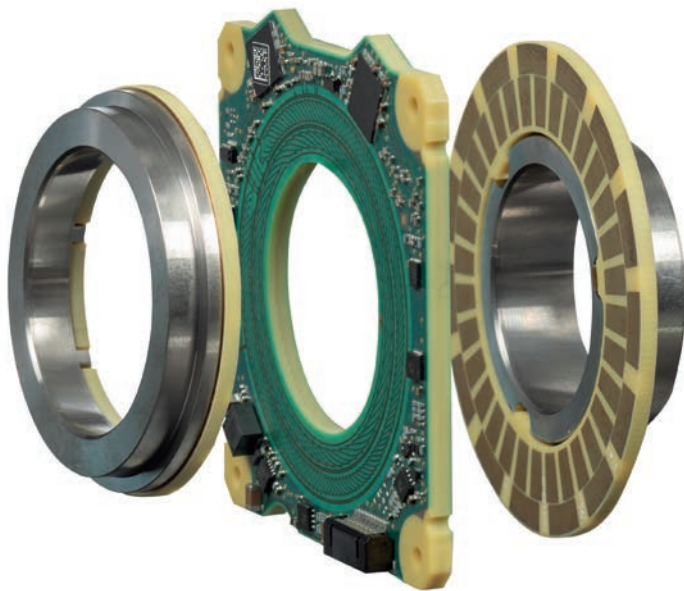

HEIDENHAIN



**Functional
Safety**

Product Information

KCI 120 Dplus

Absolute Inductive
Rotary Encoders with
Additional Functionality

Position measurement
at the output side

With additional measures:
suitable for safety-related
applications with up to SIL 3

05/2026

KCI 120 Dplus

Absolute inductive rotary encoder with additional functionality

- Robust inductive scanning principle
- Consisting of an AE scanning unit and two rotor units (TKN disk/hub assembly or TK circular scale)
- Position measurement at the output side

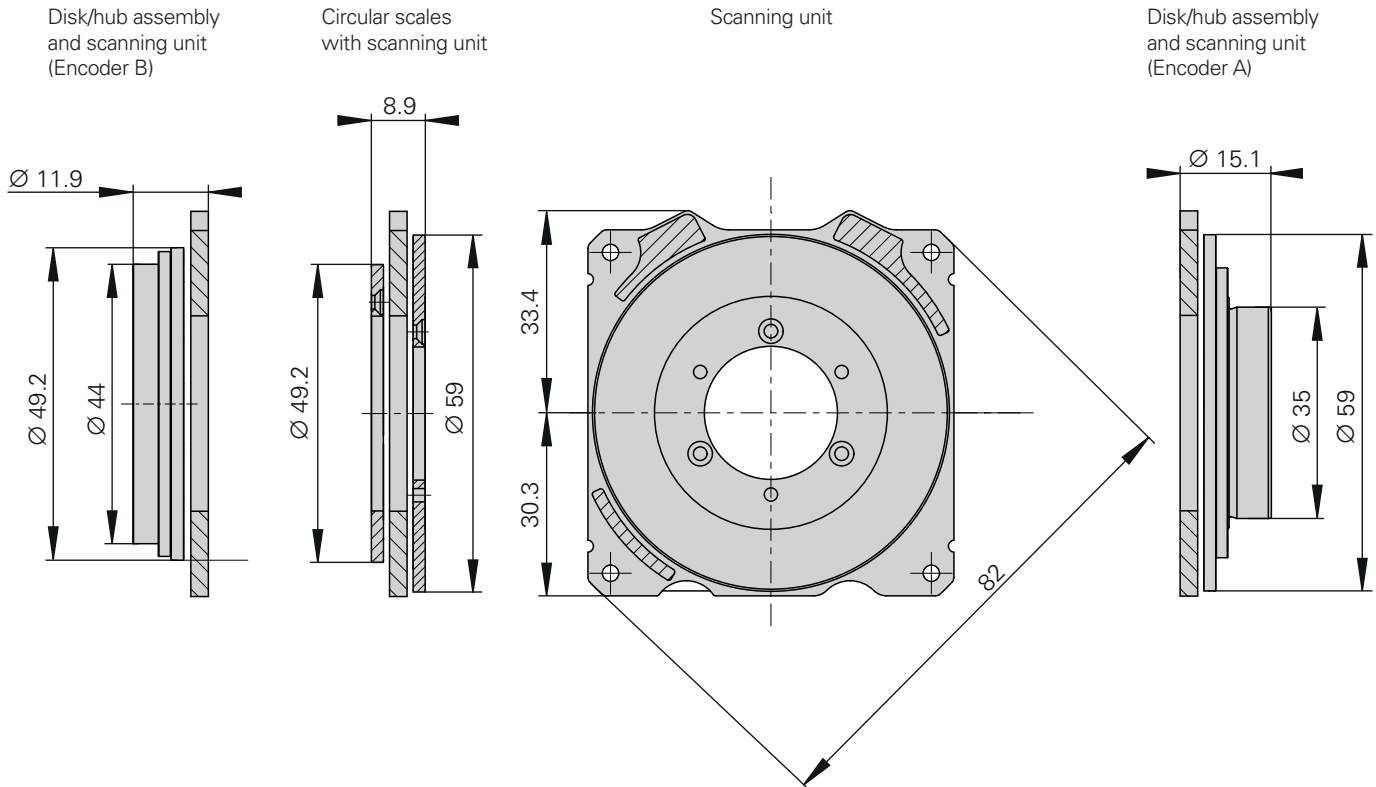
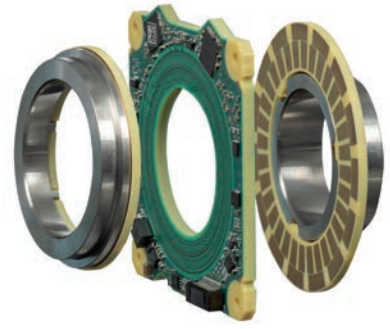

For technical drawings, visit: www.heidenhain.com/documentation



Mating dimensions

[ID 1465672](#) (scanning unit and circular scale)



Mating dimensions

[ID 1374047](#) (scanning unit and disk/hub assembly)



Mating dimensions

[ID 1373653](#) (disk/hub assembly: Encoder A)



Mating dimensions

[ID 1373392](#) (disk/hub assembly: Encoder B)

General information

Specifications	KCI 120 Dplus	
Interface	EnDat 2.2	
Ordering designation	EnDat22	
Calculation time t_{cal} Clock frequency	$\leq 5 \mu s$ $\leq 16 \text{ MHz}$	
Electrical connection	15-pin PCB connector (radial); cable length $\leq 10 \text{ m}^1$	
Supply voltage	DC 3.6 V to 14 V (for both axes together)	
Power consumption (max.) ²⁾	At 3.6 V: $\leq 1.2 \text{ W}$ At 14 V: $\leq 1.4 \text{ W}$	
Current consumption (typical)	At 5 V: 180 mA (without load)	
Angular acceleration of rotors	Disk/hub assembly (TKN): $\leq 1 \cdot 10^5 \text{ rad/s}^2$ Circular scale (TK) Encoder A: $\leq 1 \cdot 10^4 \text{ rad/s}^2$ Circular scale (TK) Encoder B: $\leq 1 \cdot 10^5 \text{ rad/s}^2$	
Vibration 55 Hz to 2000 Hz ³⁾ Shock 6 ms	Scanning unit (AE): $\leq 400 \text{ m/s}^2$; rotors: $\leq 600 \text{ m/s}^2$ (EN 60068-2-6) $\leq 2000 \text{ m/s}^2$ (EN 60068-2-27)	
Operating temperature	-40 °C to 115 °C	
Trigger threshold for exceeded temperature error message	125 °C (measuring accuracy of the internal temperature sensor: $\pm 1 \text{ K}$ at 125 °C)	
Relative humidity	$\leq 93\%$ (40 °C/21 d as per EN 60068-2-78), condensation excluded	
Protection rating EN 60529	IP00 (read about insulation under <i>Electrical safety</i> in the <i>Interfaces of HEIDENHAIN Encoders</i> brochure)	
Mass	$\approx 0.1 \text{ kg}$ (scanning unit and rotors)	
ID number	Individual packaging: ID 1362005-01 (AE scanning unit) ID 1362006-01 (disk/hub assembly: Encoder A) ID 1362007-01 (disk/hub assembly: Encoder B) ID 1473950-01 (circular scale: Encoder A) ID 1506720-01 (circular scale: Encoder B)	Collective package: ID 1362005-51 (AE scanning unit) ID 1362006-51 (disk/hub assembly: Encoder A) ID 1362007-51 (disk/hub assembly: Encoder B) ID 1473950-51 (circular scale: Encoder A) ID 1506720-51 (circular scale: Encoder B)

¹⁾ See pin layout for encoder

²⁾ See "General electrical information" in the *Interfaces of HEIDENHAIN Encoders* brochure, or visit www.heidenhain.com

³⁾ Scanning unit: 10 Hz to 55 Hz, 6.5 mm constant peak to peak
 Rotors: 10 Hz to 55 Hz, 10 mm constant peak to peak

Position measurement

Specifications	KCI 120 <i>Dplus</i> singleturn Output side (Encoder A)	KCI 120 <i>Dplus</i> singleturn Motor side (Encoder B)
Functional safety for applications with up to	As a single-encoder system for monitoring functions and control-loop functions: <ul style="list-style-type: none"> • SIL 2, as per EN 61508 (further basis for testing: IEC 61800-5-3) • Category 3, PL d, in accordance with EN ISO 13849-1:2015 With additional measures as per Document 1000344, suitable for safety-related applications with up to SIL 3 or Category 4, PL e Safe in the singleturn range of both axes	
PFH (each encoder)	SIL 2: $\leq 15 \cdot 10^{-9}$ (probability of dangerous failure per hour) SIL 3: $\leq 2 \cdot 10^{-9}$	
Safe position ¹⁾	Encoder: $\pm 0.44^\circ$ (safety-relevant measuring step SM = 0.176°) Mechanical coupling for shaft: 0° (fault exclusion for the loosening of the shaft coupling and stator coupling, designed for accelerations at the stator: $\leq 400 \text{ m/s}^2$; at the rotor: $\leq 600 \text{ m/s}^2$)	
Shaft	Hub with an inside diameter of 29 mm Circular scale with inside hub diameter of 21 mm	Hub with an inside diameter of 34 mm Circular scale with inside hub diameter of 32 mm
Spindle speed	$\leq 6000 \text{ rpm}$	$\leq 15000 \text{ rpm}$
Moment of inertia of rotor	TK: $4.51 \cdot 10^{-6} \text{ kg} \cdot \text{m}^2$ TKN: $17 \cdot 10^{-6} \text{ kgm}^2$	TK: $1.82 \cdot 10^{-6} \text{ kg} \cdot \text{m}^2$ TKN: $15 \cdot 10^{-6} \text{ kgm}^2$
Axial motion ²⁾	$\pm 0.3 \text{ mm}$	$\pm 0.5 \text{ mm}$
Position values per rev.	1 048 576 (20 bits)	524 288 (19 bits)
System accuracy	$\pm 40''$	$\pm 120''$

¹⁾ Further tolerances may arise in the downstream electronics after position value comparison (contact mfr.)

²⁾ Including thermal linear expansion and mounting tolerance

Mounting

Mounting and protection rating

Mounting and protection rating

Mounting the KCI 120 *Dplus* consists of the following: alignment and mounting of the scanning unit, and press-fitting the two disk/hub assemblies or screw-fastening the circular scales. The disk/hub assemblies are press-fitted onto the respective shaft, whereas the circular scales are screw-fastened, and the scanning unit is mounted to the mating surface via the four holes. Alignment can optionally be performed with a centering collar, with cylindrical pins, or with a mounting device.

The press-fitting process may be performed only once for each disk/hub assembly. For press-fitting, adhere to the material properties and the conditions for the mating surfaces stated in the relevant documents for use. These requirements must be followed, even when new disk/hub assemblies are press-fitted onto a mating shaft that has already been used.

Once the lower limit of the pressing force has been exceeded, the pressing force being applied must remain within the specified range for the rest of the procedure, including until the final position is reached. If the application features functional safety, then, after the mounting or installation of the encoder onto the mating surface, the device must be protected from at least the ingress of solid foreign objects in accordance with an IP6x protection rating, as well as from the ingress of liquids (the protection rating for liquids depends on the application; e.g., IPx5: protection from water jets). If exposure to contamination such as dust and liquids can be excluded, then a protection rating of at least IP40 when mounted is sufficient.



For more information:

Follow the measures for *electromagnetic compatibility* described in the "General electrical information" in the *Interfaces of HEIDENHAIN Encoders* brochure to ensure disturbance-free operation.

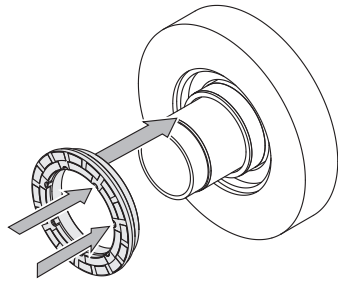

Press-fit the disk/hub assembly (Encoder B)

or

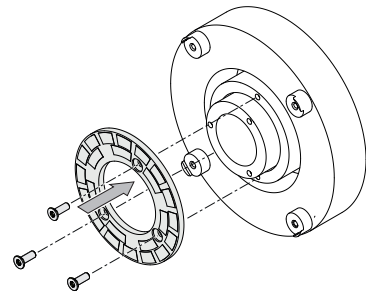

Screw-fasten the circular scale (Encoder B)

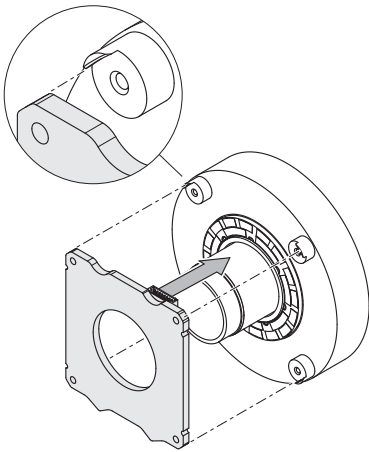

Align with centering collar

or

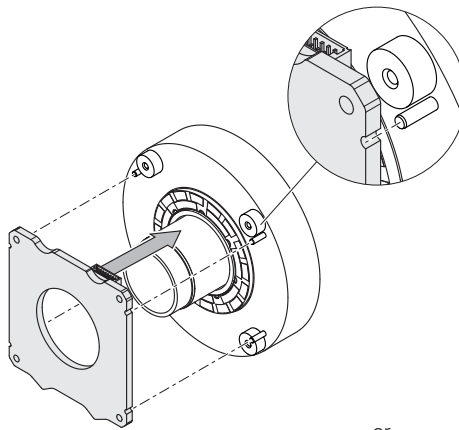

Align with cylindrical pins

or

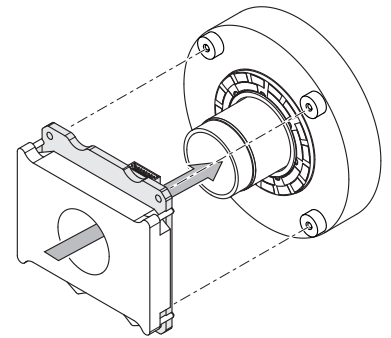

Align with mounting device

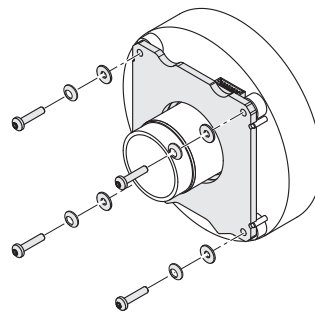

Mount the scanning unit

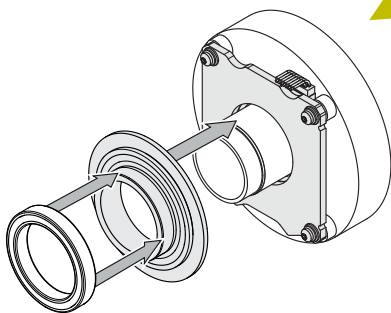

Press-fit the disk/hub assembly (Encoder A)

or

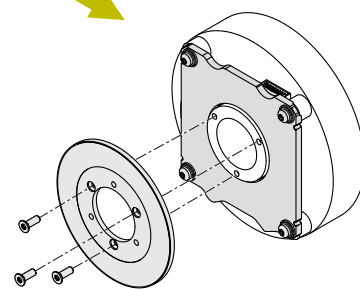

Screw-fasten the circular scale (Encoder A)

For the design of the fault exclusion, the following material properties and conditions for the mating surfaces are assumed.

	Mating shaft ¹⁾ , mating stator	Mating shaft, mating stator
Material	Aluminum	Steel
Tensile strength R_m	$\geq 220 \text{ N/mm}^2$	$\geq 600 \text{ N/mm}^2$
Yield strength $R_{p0.2}$ or yield point R_e	–	$\geq 400 \text{ N/mm}^2$
Shear strength τ_a	130 N/mm^2	$\geq 390 \text{ N/mm}^2$
Interface pressure P_G	$\geq 250 \text{ N/mm}^2$	$\geq 660 \text{ N/mm}^2$
Modulus of elasticity E (at 20 °C)	70 kN/mm^2 to 75 kN/mm^2	200 kN/mm^2 to 215 kN/mm^2
Coefficient of thermal expansion α_{therm} (at 20 °C)	$\leq 25 \cdot 10^{-6} \text{ K}^{-1}$	Screw-fastened version: $10 \cdot 10^{-6} \text{ K}^{-1}$ to $17 \cdot 10^{-6} \text{ K}^{-1}$ Press-fitted version: $10 \cdot 10^{-6} \text{ K}^{-1}$ to $12 \cdot 10^{-6} \text{ K}^{-1}$
Surface roughness R_z	$\leq 16 \text{ }\mu\text{m}$	
Friction values	Mounting surfaces must be clean and free of grease. Use screws and washers from HEIDENHAIN in their condition as delivered.	
Tightening procedure	Use a signal-emitting torque wrench in accordance with DIN EN ISO 6789, with an accuracy of $\pm 6\%$	
Mounting temperature	$15 \text{ }^\circ\text{C}$ to $35 \text{ }^\circ\text{C}$	

¹⁾ Only when screw-fastened circular scale is used

Mounting aid

To avoid damage to the cable, use the mounting aid to disconnect the cable assembly. Apply pulling force solely to the connector of the cable assembly and not to the wires.



ID 1075573-01

Mounting accessories

Screws: M2.5 x 12 ISO 4762 or ISO 14583 – 8.8 – MKL, and
spring washers: DIN 6796 – 2.5 – FSt.

Washer: ID 1334909-01

Instructions for use: use screws with material bonding anti-rotation lock as per DIN 26727 (see "General mechanical information" in the *General mechanical information* brochure). Fastening-screws and spring washers must be ordered separately.

For more mounting information and mounting aids, see the Mounting Instructions and the *Encoders for Servo Drives* brochure. The mounting quality can be checked with the PWM 21 and the ATS software (see document ID 1082415).

Built-in temperature evaluation

Each axis of these rotary encoders features an internal temperature sensor integrated into the encoder's electronics. The digitized temperature value is transmitted purely serially via the EnDat protocol. Please bear in mind that this measurement and transmission of the temperature is not safe in terms of functional safety.

Regarding the internal temperature sensor, the rotary encoder supports the two-stage cascaded signaling of a temperature exceedance. This consists of an EnDat warning and an EnDat error message.

In accordance with the EnDat specification, an EnDat warning (EnDat memory area "Operating status," word 1 "Warnings," bit 2¹ "Temperature exceeded") is output when the warning threshold for the temperature exceedance of the internal temperature sensor is reached. This warning threshold for the internal temperature sensor is stored in the EnDat memory area "Operating parameters," word 6 "Trigger threshold warning bit for excessive temperature" of each axis, and can be individually adjusted.

A device-specific default value is saved here before the encoder is shipped. The temperature measured by the internal temperature sensor is higher by a device-specific and application-specific amount than the temperature at the measuring point as shown in the dimension drawing.

Each axis of the rotary encoders features a further, albeit non-adjustable trigger threshold for the "Temperature exceeded" EnDat error message of the internal temperature sensor. When this is reached, an EnDat error message is output (EnDat memory area "Operating status," word 0 "Error messages," bit 2² "Position" and in additional data 2 "Operating status error sources," bit 2⁶ "Temperature exceeded"). This trigger threshold may vary depending on the encoder and is stated in the specifications.

HEIDENHAIN recommends adjusting the warning threshold based on the application such that this threshold is sufficiently below the trigger threshold for the "Temperature exceeded" EnDat error message. Compliance with the temperature at the measuring point is required for adherence to the encoder's intended and proper use.

Electrical resistance

Check the electrical resistance between the customer-side stator and both customer-side shafts. Nominal value: < 1 ohm

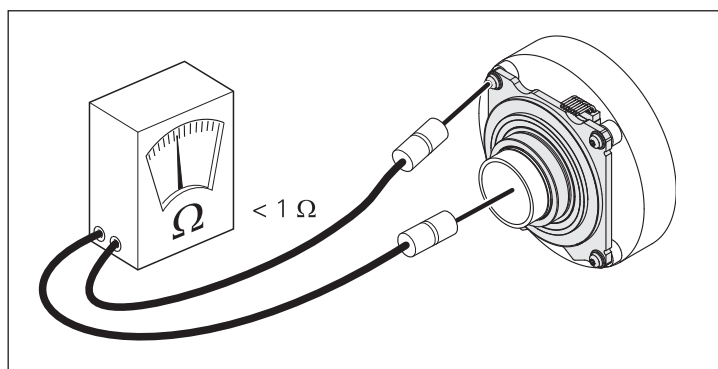

Testing and inspection units, and diagnostics

HEIDENHAIN encoders provide all of the information needed for setup, monitoring, and diagnostics. The type of information available depends on whether the encoder is incremental or absolute and on which interface is being used.

Absolute encoders employ serial data transmission. The signals are extensively monitored within the encoder. The monitoring results (particularly valuation numbers) can be transmitted to the downstream electronics along with the position values via the serial interface (**digital diagnostic interface**). The following information is available:

- Error message: position value is not reliable
- Warning: an internal functional limit of the encoder has been reached
- Valuation numbers:
 - Detailed information about the encoder's function reserve
 - Identical scaling for all HEIDENHAIN encoders
 - Cyclic reading capability

This enables the downstream electronics to evaluate the current status of the encoder with little effort, even in closed-loop mode.

For the analysis of these encoders, HEIDENHAIN offers the relevant PWM inspection units and PWT testing units. Based on how these units are integrated, a distinction is made between two types of diagnostics:

- Encoder diagnostics: the encoder is connected directly to the testing or inspection unit, thereby enabling a

detailed analysis of the encoder's functions.

- Monitoring mode: the PWM inspection unit is inserted within the closed control loop (via suitable testing adapters as needed). This enables real-time diagnosis of the machine or equipment during operation. The available functions depend on the interface.

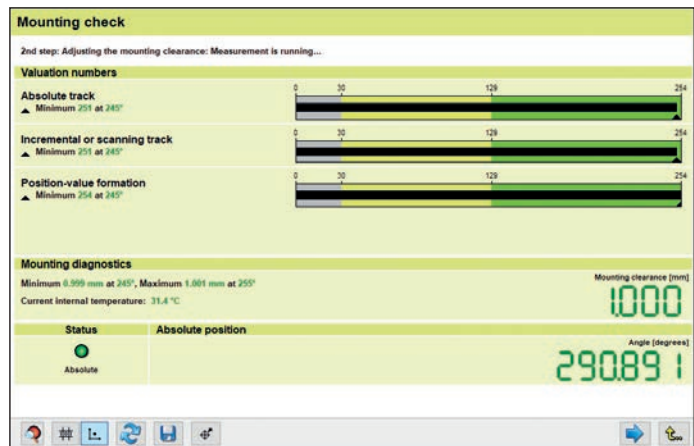

Mounting accuracy with the PWM 21 and ATS software

PWM 21

The PWM 21 phase-angle measuring unit, in conjunction with the included ATS adjusting and testing software, serves as an adjusting and testing package for the diagnosis and adjustment of HEIDENHAIN encoders.



For more information, see the *PWM 21, ATS Software* Product Information document.

	PWM 21
Encoder input	<ul style="list-style-type: none"> • EnDat 2.1, EnDat 2.2, or EnDat 3 (absolute value with or without incremental signals) • DRIVE-CLiQ • Fanuc Serial Interface • Mitsubishi high speed interface • Yaskawa Serial Interface • Panasonic Serial Interface • SSI • 1 V_{PP}/TTL/11 μA_{PP} • HTL (via signal adapter)
Interface	USB 2.0
Supply voltage	AC 100 V to 240 V or DC 24 V
Dimensions	258 mm × 154 mm × 55 mm

DRIVE-CLiQ is a registered trademark of Siemens AG.



Electrical connection

Connecting a special testing cable to the PWM 21 diagnostic and inspection unit establishes a connection with Encoder A (output side). Encoder B (motor side) is connected via a different special testing cable.

HEIDENHAIN offers two testing cables for this purpose. As a result, either a testing cable for the output-side encoder or a testing cable for the motor-side encoder can be connected to the PWM 21 as needed.

Pin layout of the testing cables

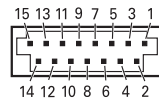

Testing cable for connection to Encoder A: 1311046-xx

15-pin PCB connector					Serial data transmission (Encoder A)			
					7	8	9	10
	Supply voltage				Serial data transmission (Encoder A)			
	14	12	13	11	7	8	9	10
	0V	Sensor 0V	U_P	Sensor U_P	DATA A	DATA \bar{A}	CLOCK A	CLOCK \bar{A}
	White/Green	White	Brown/Green	Blue	Gray	Pink	Violet	Yellow

U_P = Power supply

Vacant pins or wires must not be used!

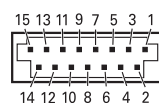

Testing cable for connection to Encoder B: 1311047-xx

15-pin PCB connector					Serial data transmission (Encoder B)			
					1	2	3	4
	Supply voltage				Serial data transmission (Encoder B)			
	14	12	13	11	1	2	3	4
	0V	Sensor 0V	U_P	Sensor U_P	DATA B	DATA \bar{B}	CLOCK B	CLOCK \bar{B}
	White/Green	White	Brown/Green	Blue	Gray	Pink	Violet	Yellow

U_P = Power supply

Vacant pins or wires must not be used!

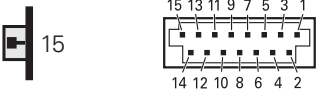
Pin layout for the rotary encoder

15-pin PCB connector											
											
Supply voltage				Serial data transmission (Encoder A)				Serial data transmission (Encoder B)			
14	12	13	11	7	8	9	10	1	2	3	4
0V	Sensor 0V	U _P	Sensor U _P	DATA A	DATA A	CLOCK A	CLOCK A	DATA B	DATA B	CLOCK B	CLOCK B
											

U_P = Power supply

Vacant pins or wires must not be used!

The downstream electronics must have a common ground reference!

Cable length > 0.5 m:

To prevent crosstalk, the two EnDat interfaces must be separately shielded from each other. The cable sold by the meter with ID 1347450-xx (PUR, Ø 3.7 mm) can be used for this. Two cables must be attached to the PCB connector in order to transmit the EnDat signals separately. Only one cable is used for the power supply. When using the cable sold by the meter with ID 1347450-xx, comply with the general information in the *Cables and Connectors* brochure; use of the cables at temperatures of up to 100 °C is possible, provided that the exposure to hydrolysis and harmful media is low.

Cable length ≤ 0.5 m:

When single wires with up to a maximum length of 0.5 m are used, each data and clock wire combination must be implemented as a twisted wire pair in order to avoid coupled interferences. As an alternative, the cable with ID 605090-51 (EPG, Ø 4.5 mm) and a length of 0.3 m can be used. The general information in the *Cables and Connectors* brochure must be taken into account.

HEIDENHAIN

DR. JOHANNES HEIDENHAIN GmbH

Dr.-Johannes-Heidenhain-Straße 5

83301 Traunreut, Germany

+49 8669 31-0

+49 8669 32-5061

info@heidenhain.de

www.heidenhain.com

This Product Information document supersedes all previous editions, which thereby become invalid. The basis for ordering from HEIDENHAIN is always the Product Information document edition valid when the order is placed.



More information:

Comply with the requirements described in the following documents to ensure correct and intended operation:

- Operating Instructions: TKN KCI 120 Dplus 1375948-xx
- Operating Instructions: AE KCI 120 Dplus 1394882-xx
- Operating Instructions: TK KCI 120 Dplus 1508279-xx