



HEIDENHAIN



**Functional
Safety**

Product Information

KCI 1119

KBI 1135

Absolute Inductive
Rotary Encoders without
Integral Bearing

With additional measures:
suitable for safety-related
applications with up to SIL3

07/2025

KCI 1119, KBI 1135

Rotary encoders for absolute position values

- Robust inductive scanning principle
- Consisting of a scanning unit (AE) and a rotor unit

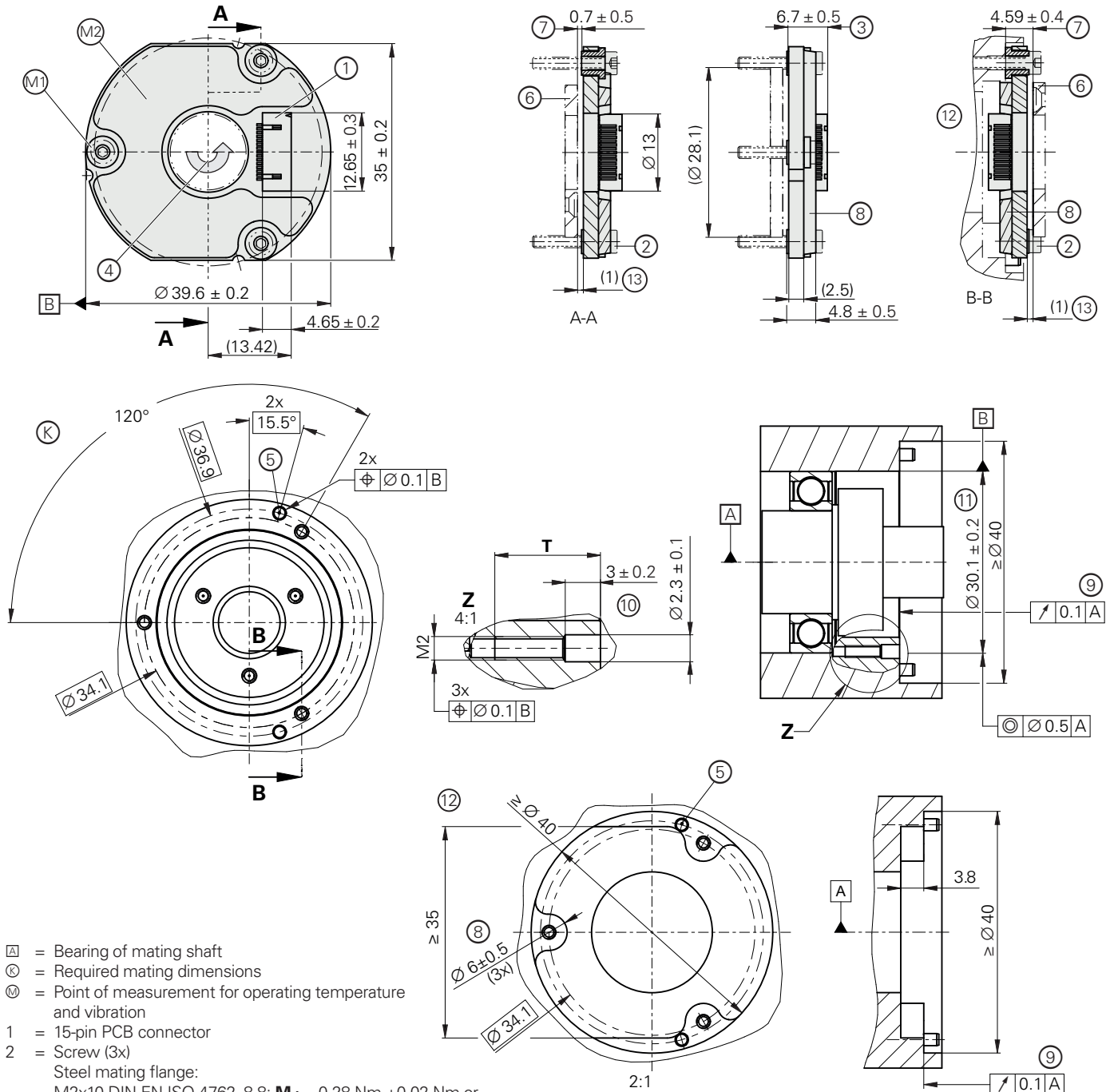

- ▣ = Bearing of mating shaft
- ⊗ = Required mating dimensions
- ⊙ = Point of measurement for operating temperature and vibration

- 1 = 15-pin PCB connector
- 2 = Screw (3x)
Steel mating flange:
M2x10 DIN EN ISO 4762-8.8; $M_d = 0.28 \text{ Nm} \pm 0.02 \text{ Nm}$ or
M2x10 DIN EN ISO 14583-8.8; $M_d = 0.28 \text{ Nm} \pm 0.02 \text{ Nm}$
Aluminum mating flange:
M2x12 DIN EN ISO 4762-8.8; $M_d = 0.28 \text{ Nm} \pm 0.02 \text{ Nm}$ or
M2x12 DIN EN ISO 14583-8.8; $M_d = 0.28 \text{ Nm} \pm 0.02 \text{ Nm}$

- 3 = Ensure space for PCB connector and cable
- 4 = Direction of shaft rotation for ascending position values
- 5 = Alignment via 2h7 cylindrical pins in the flange or via mounting aid
- 6 = Separate TK/TKN, with different variants possible; for mounting, see the respective mating dimensions model
- 7 = Mounting clearance between the circular scale surface and the flange surface; compensation of mounting tolerances and thermal expansion; dynamic motion permitted over entire range
(when the ATS software is used for the mounting inspection, the display value for the mounting clearance is shown as 1 mm)

- 8 = Ensure space for electronics; see also the mating dimensions model
- 9 = Flange surface
- 10 = Cylindrical cavity to ensure the grip-length ratio
- 11 = Size of diameter, including chamfer
- 12 = Backwards mounting
- 13 = Nominal scanning gap

Mating stator	T
Steel	≥ 7
Aluminum	≥ 9

mm

Tolerancing ISO 8015
 ISO 2768:1989-mH
 ≤ 6 mm: ±0.2 mm

Rotor fastening via three axial countersunk head screws

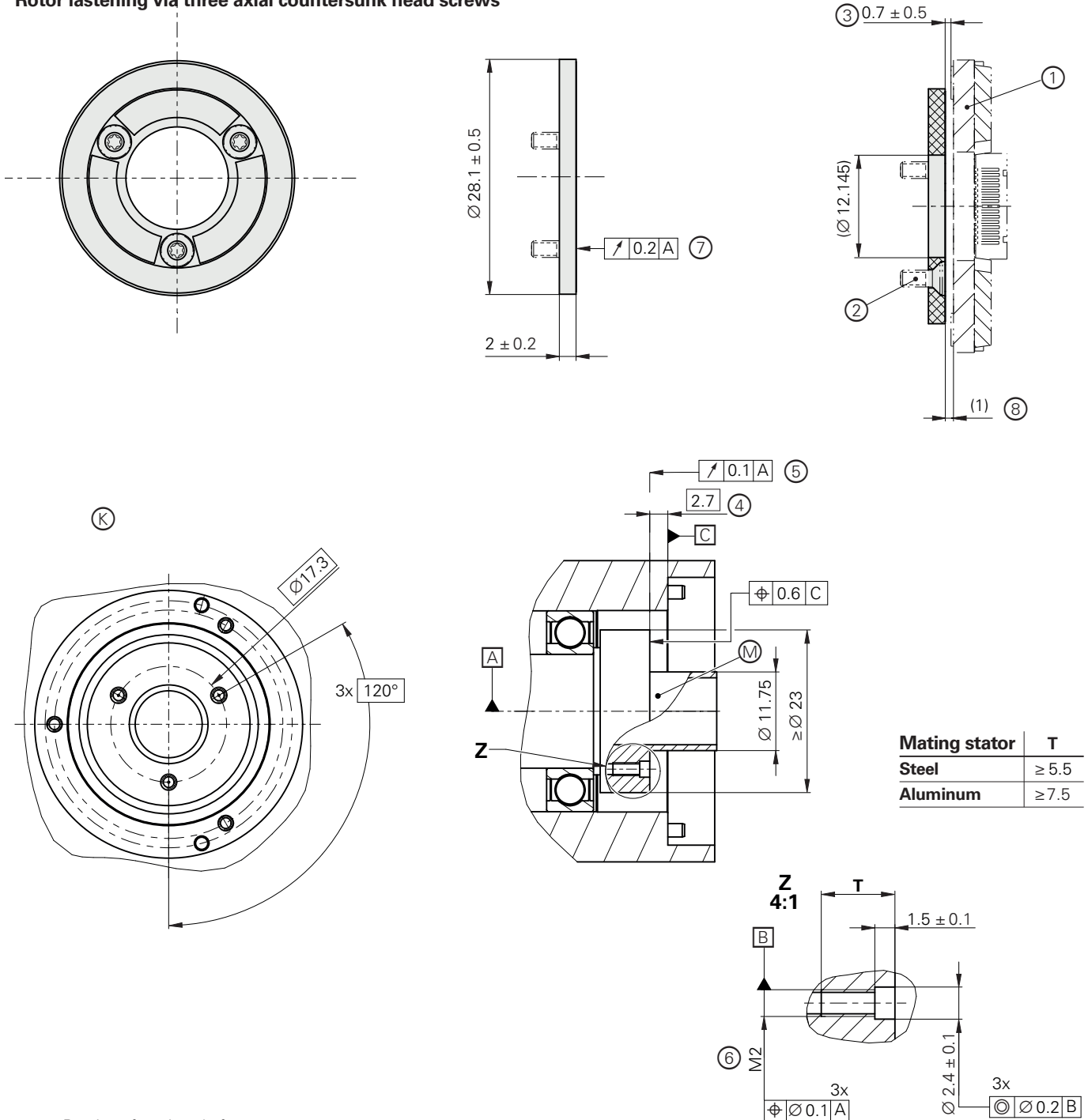

- ⊠ = Bearing of mating shaft
- ⊙ = Required mating dimensions
- ⊕ = Point of measurement for operating temperature
- 1 = Separate scanning unit (AE); different variants possible; for mounting, see the respective mating dimensions model
- 2 = Countersunk screw (3x); protrusion of screw head not permitted;
steel mating shaft: M2x6 DIN EN ISO 14581-A2-070; $M_d = 0.25 \text{ Nm} \pm 0.015 \text{ Nm}$;
aluminum mating shaft: M2x8 DIN EN ISO 14581-A2-070; $M_d = 0.25 \text{ Nm} \pm 0.015 \text{ Nm}$
- 3 = Mounting clearance between the circular scale surface and the flange surface; compensation of mounting tolerances and thermal expansion;
dynamic motion permitted over entire range
(when the ATS software is used for the mounting inspection, the display value for the mounting clearance is shown as 1 mm)
- 4 = Distance between AE flange surface and circular scale surface
- 5 = Circular scale surface
- 6 = Use suitable material bonding anti-rotation lock (at least medium strength)
- 7 = On the fine track ($\varnothing 21.4 \text{ mm}$ to $\varnothing 27.6 \text{ mm}$), after being screw-fastened
- 8 = Nominal scanning gap

mm

 Tolerancing ISO 8015
 ISO 2768:1989-mH
 $\leq 6 \text{ mm}$: $\pm 0.2 \text{ mm}$

Rotor fastening via press-fitted hub

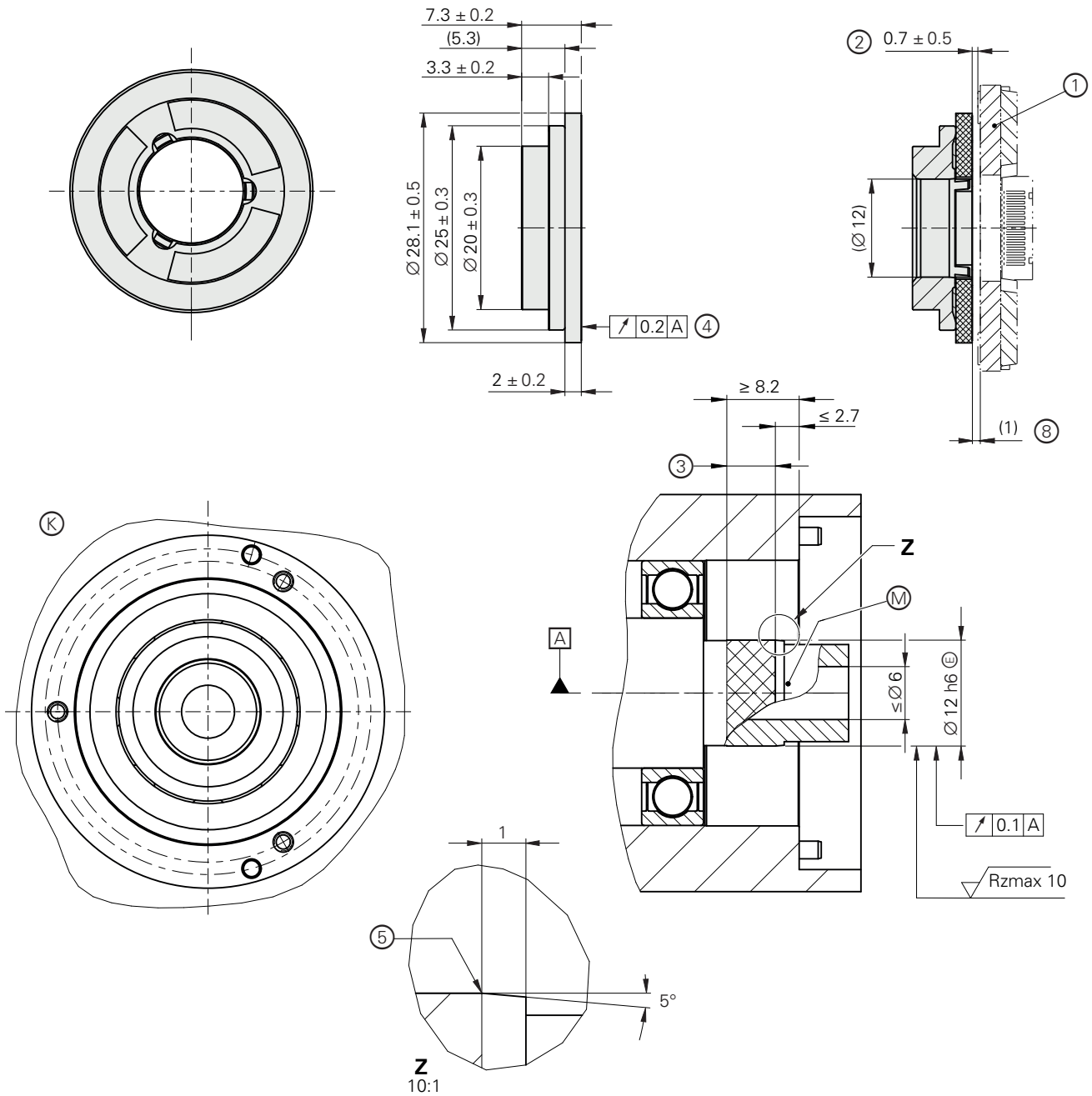

- ▣ = Bearing of mating shaft
- ⊙ = Required mating dimensions
- ⊙ = Point of measurement for operating temperature
- 1 = Separate scanning unit (AE); different variants possible; for mounting, see the respective mating dimensions model
- 2 = Mounting clearance between the circular scale surface and the flange surface; compensation of mounting tolerances and thermal expansion; dynamic motion permitted over entire range (when the ATS software is used for the mounting inspection, the display value for the mounting clearance is shown as 1 mm)
- 3 = For press-fitting parameters, see the Mounting Instructions
- 4 = On the fine track ($\varnothing 21.4 \text{ mm}$ to $\varnothing 27.6 \text{ mm}$), after press-fitting
- 5 = Rounded transition to the fit surface: $R_{\max} = 0.5 \text{ mm}$
- 6 = Nominal scanning gap

Specifications	KCI 1119 singletum	KBI 1135 multitum
Functional safety for applications with up to	As a single-encoder system for monitoring functions and control-loop functions: <ul style="list-style-type: none"> • SIL 2, as per EN 61508 (further basis for testing: IEC 61800-5-3) • Category 3, PL d, in accordance with EN ISO 13849-1:2015 With additional measures as per Document 1000344, suitable for safety-related applications with up to SIL 3 or Category 4, PL e Safe in the singleturn range	
PFH	SIL 2: $\leq 15 \cdot 10^{-9}$ (probability of dangerous failure per hour) SIL 3: $\leq 2 \cdot 10^{-9}$	
Safe position ¹⁾	Encoder: $\pm 0.88^\circ$ (safety-relevant measuring step SM = 0.35°) Mechanical coupling: 0° (fault exclusion for the loosening of the shaft coupling and stator coupling; designed for accelerations at the stator of $\leq 400 \text{ m/s}^2$; at the rotor: $\leq 600 \text{ m/s}^2$)	
Interface	EnDat 2.2	
Ordering designation	EnDat22	
Position values per rev.	524288 (19 bits)	
Revolutions	–	65563 (16 bits)
Calculation time t_{cal} Clock frequency	$\leq 5 \mu\text{s}$ $\leq 16 \text{ MHz}$	
Analog delay time t_{AD} (typical)	13.9 μs	
System accuracy	$\pm 60''$	
Electrical connection	15-pin PCB connector (with connection for external temperature sensor)	
Cable length	$\leq 100 \text{ m}$ (see EnDat description in the <i>Interfaces of HEIDENHAIN Encoders</i> brochure)	
Power supply	DC 3.6 V to 14 V	U_{P} for rotary encoder: DC 3.6 V to 14 V Backup battery ⁴⁾ U_{Bat} : DC 3.6 V to 5.25 V
Power consumption ²⁾ (max.)	At 3.6 V: $\leq 650 \text{ mW}$ At 14 V: $\leq 750 \text{ mW}$	
Current consumption (typical)	At 5 V: 100 mA (without load)	Normal operation at 5 V: 100 mA (without load) Backup battery: 230 μA (rotating shaft) ³⁾ 22 μA (at standstill)
Part number	AE KCI 1119 scanning unit 1418388-01	AE KBI 1135 scanning unit 1418390-01
	Circular scale (screw-fastened version) 1418392-01 (12.25 mm) Disk/hub assembly (press-fitted version) 1418391-01 (12 mm)	

¹⁾ Further tolerances may arise in the downstream electronics after position value comparison (contact mfr.)

²⁾ See *General electrical information* in the *Interfaces of HEIDENHAIN Encoders* brochure, or visit www.heidenhain.com

³⁾ At $T = 25^\circ\text{C}$; $U_{\text{Bat}} = 3.6 \text{ V}$

⁴⁾ The typical service life is six years when recommended batteries are used and under corresponding conditions (two 10-hour shifts under normal operation; battery temperature: 25°C ; typical self-discharge)

Specifications	KCI 1119 singletum	KBI 1135 multitum
Rotor*	Press-fitted disk/hub assembly (hub inside diameter: 12 mm) Screw-fastened circular scale (inside diameter: 12.25 mm)	
Shaft speed	≤ 10 000 rpm	
Moment of inertia	Disk/hub assembly: $1.0 \cdot 10^{-6} \text{ kgm}^2$ Circular scale: $0.2 \cdot 10^{-6} \text{ kgm}^2$	
Angular acceleration of rotor ¹⁾	≤ $1 \cdot 10^5 \text{ rad/s}^2$	
Axial motion of measured shaft	≤ ±0.5 mm ²⁾	
Vibration 55 Hz to 2000 Hz ³⁾ Shock 6 ms	Stator: ≤ 400 m/s ² ; rotor: ≤ 600 m/s ² (EN 60068-2-6) ≤ 2000 m/s ² (EN 60068-2-27)	
Operating temperature	−40 °C to 115 °C	
Trigger threshold of error message for excessive temperature	123 °C (measuring accuracy of the internal temperature sensor: ±1 K)	
Relative humidity	≤ 93% (40 °C/21 d as per EN 60068-2-78), condensation excluded	
Protection EN 60529	IP00	
Mass	≈ 0.02 kg (scanning unit + disk/hub assembly) ≈ 0.01 kg (scanning unit + circular scale)	

* Please select when ordering

1) With multiturn functionality in normal operation; maximum permissible acceleration in backup-battery mode upon request

2) Backwards mounting: ±0.4 mm

3) 10 Hz to 55 Hz, 4.9 mm constant peak to peak

Mounting

The KCI 1119/KBI 1135 is mounted either via screw-fastening of the circular scale or through press-fitting of the disk/hub assembly, followed by mounting of the scanning unit. The disk/hub assembly is thereby press-fitted onto the shaft, or the circular scale is screw-fastened to the given shaft with three screws. The scanning unit is aligned and mounted onto the mating surface via three holes. For alignment, two pins or a mounting aid can be used.

The press-fitting process may be performed only once for each disk/hub assembly. For press-fitting, adhere to the material properties and conditions for the mating surface stated in the relevant documents for proper use. These requirements must be followed, even when new disk/hub assemblies are press-fitted onto customer shafts that have already been used. The maximum pressing force must not be

exceeded throughout the press-fitting procedure. Once the lower limit of the pressing force has been exceeded, the pressing force being applied must remain within the specified range for the rest of the procedure, including until the final position is reached. If the scanning unit is installed first, then it can be mounted backwards.

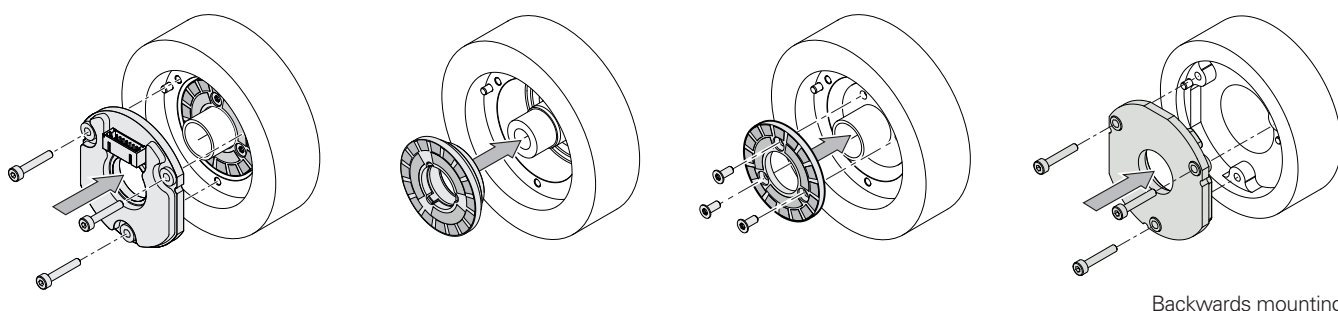

Backwards mounting

The following material properties and conditions must be complied with when customers plan and execute installation:

	Mating shaft ¹⁾ , mating stator	Mating shaft, mating stator
Material	Aluminum	Steel
Tensile strength R_m	$\geq 220 \text{ N/mm}^2$	$\geq 600 \text{ N/mm}^2$
Yield strength $R_{p0.2}$ or yield point R_e	–	$\geq 400 \text{ N/mm}^2$
Shear strength τ_a	130 N/mm^2	$\geq 390 \text{ N/mm}^2$
Interface pressure P_G	$\geq 250 \text{ N/mm}^2$	$\geq 660 \text{ N/mm}^2$
Modulus of elasticity E (at 20 °C)	70 kN/mm^2 to 75 kN/mm^2	200 kN/mm^2 to 215 kN/mm^2
Coefficient of thermal expansion α_{therm} (at 20 °C)	$\leq 25 \cdot 10^{-6} \text{ K}^{-1}$	Screw-fastened version: $10 \cdot 10^{-6} \text{ K}^{-1}$ to $17 \cdot 10^{-6} \text{ K}^{-1}$ Press-fitted version: $10 \cdot 10^{-6} \text{ K}^{-1}$ to $12 \cdot 10^{-6} \text{ K}^{-1}$
Surface roughness R_z	$\leq 16 \text{ }\mu\text{m}$	
Friction values	Mounting surfaces must be clean and free of grease. Use screws and washers from HEIDENHAIN in their condition as delivered.	
Tightening procedure	Use a signal-emitting torque wrench in accordance with DIN EN ISO 6789, with an accuracy of $\pm 6 \%$	
Mounting temperature	15 °C to 35 °C	

¹⁾ Only when screw-fastened circular scale is used

Mounting accessories

Screws

Screws (fastening screws) are not included in delivery.

M3x8 and M3x10 screws with material bonding anti-rotation lock can be ordered separately.

KCI 1119 KBI 1135	Mating shaft, mating stator	Screws
Screw for fastening the scanning unit	Steel	ISO 4762- M2x10 -8.8 ISO 14583- M2x10 -8.8
	Aluminum	ISO 4762- M2x12 -8.8 ISO 14583- M2x12 -8.8
Fastening screw for circular scale	Steel Aluminum	ISO 14581- M2x6 -A2-070 ¹⁾ ISO 14581- M2x8 -A2-070 ¹⁾

¹⁾ Screw without material-bonding anti-rotation lock; a material-bonding anti-rotation lock of at least medium strength must be used

Mounting aid

To avoid damage to the cable, use the mounting aid to connect and disconnect the cable assembly. Apply pulling force solely to the connector of the cable assembly and not to the wires.



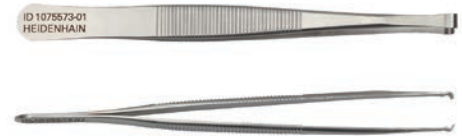

ID 1075573-01

For more mounting information and mounting aids, see the **Mounting Instructions** and the *Encoders for Servo Drives* brochure. The mounting quality can be inspected with the PWM 21 and the ATS software (see document 1082415).

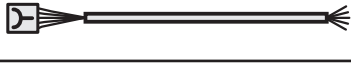

Electrical connection

Cables

Output cables inside the motor housing with TPE single wires ($8 \times 0.16 \text{ mm}^2$) and net sleeve without shield		
With 15-pin PCB connector and 8-pin M12 straight flange socket (male) with TPE single wires for temperatures sensor ($2 \times 0.16 \text{ mm}^2$)		ID 1119952-xx
With 15-pin PCB connector and 8-pin M12 straight flange socket (male)		ID 804201-xx
With 15-pin PCB connector with TPE single wires for temperature sensor ($2 \times 0.16 \text{ mm}^2$) and stripped cable end		ID 1119958-xx ¹⁾
Output cable inside the motor housing with TPE single wires ($8 \times 0.16 \text{ mm}^2$) and heat shrink tubing without a shield		
With 15-pin PCB connector and stripped cable end		ID 640055-xx ¹⁾
Output cable for HMC 6: $\varnothing 3.7 \text{ mm EPG } 1 \times (4 \times 0.06 \text{ mm}^2) + 4 \times 0.06 \text{ mm}^2$		
With 15-pin PCB connector and contact insert for 6-pin HMC 6 hybrid connector (male), with TPE single wires for temperature sensor ($2 \times 0.16 \text{ mm}^2$), with cable clamp for shield connection		ID 1072652-xx







¹⁾ Connecting element must be suitable for the maximum clock frequency used

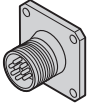

More information:

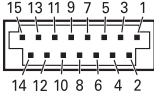
For connecting cables and adapter cables, see the *Cables and Connectors* brochure.

Pin layout for KCI 1119







8-pin M12 flange socket					15-pin PCB connector						
											
	Power supply				Serial data transmission				Other signals		
	8	2	5	1	3	4	7	6	/	/	
	13	11	14	12	7	8	9	10	5	6	
	U_P	Sensor U_P	0V	Sensor 0V	DATA	$\overline{\text{DATA}}$	CLOCK	$\overline{\text{CLOCK}}$	T+	T-	
	Brown/ Green	Blue	White/ Green	White	Gray	Pink	Violet	Yellow	Brown	Green	

Cable shield connected to housing; U_P = Power supply voltage; T = Temperature

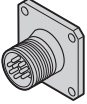
Sensor: The sense line is connected in the encoder with the corresponding power line.

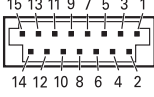
Vacant pins or wires must not be used!

Pin layout for KBI 1135

8-pin M12 flange socket					15-pin PCB connector						
											
	Power supply				Serial data transmission				Other signals		
	8	2	5	1	3	4	7	6	/	/	
	13	11	14	12	7	8	9	10	5	6	
	U_P	U_{BAT}	0V ¹⁾	0V _{BAT} ¹⁾	DATA	$\overline{\text{DATA}}$	CLOCK	$\overline{\text{CLOCK}}$	T+	T-	
	Brown/ Green	Blue	White/ Green	White	Gray	Pink	Violet	Yellow	Brown	Green	

U_P = Power supply; U_{BAT} = external backup battery (false polarity can result in damage to the encoder)

Vacant pins or wires must not be used!

¹⁾ Connected inside encoder

HEIDENHAIN

DR. JOHANNES HEIDENHAIN GmbH

Dr.-Johannes-Heidenhain-Straße 5

83301 Traunreut, Germany

☎ +49 8669 31-0

☎ +49 8669 32-5061

✉ info@heidenhain.de

www.heidenhain.com

This Product Information document supersedes all previous editions, which thereby become invalid. The basis for ordering from HEIDENHAIN is always the Product Information document edition valid when the order is placed.



More information:

Comply with the requirements described in the following documents to ensure correct and intended operation:

- Operating Instructions: AE KCI 1119, KBI 1135 (HW12), FS 1438001-xx
- Operating Instructions: TK/TKN KCI 1119, KBI 1135 (HW12), FS 1438002-xx