



HEIDENHAIN



Product Information

HMC 6

Hybrid Motor Cable

HMC 6

Single-cable solution for servomotors

Servomotors normally require two separate cables:

- One cable for the motor encoder
- One cable for the motor power supply

With the **HMC 6** (Hybrid Motor Cable), HEIDENHAIN has integrated the encoder wires into the power cable. Thus, now only **a single cable** is needed between the motor and electrical cabinet.

The HMC 6 single-cable solution was specifically designed for the HEIDENHAIN **EnDat22** interface with purely serial data transmission at a cable length of up to 100 m. However, any encoder with a purely serial RS-485 interface can be connected as well. A wide range of encoders can therefore be used without the need for introducing a new interface.

The HMC 6 solution combines the wires for the encoder, motor, and brake into a single cable. This cable is connected to the motor with a special connector. For connection to the inverter, the cable is split into power connections, brake connections, and encoder connectors, so that all of the familiar components can continue to be used on the control.

When these components are correctly connected, the connecting elements attain an IP67 rating. A quick-release lock and vibration protection against the loosening of coupling joints are integrated into the connector.

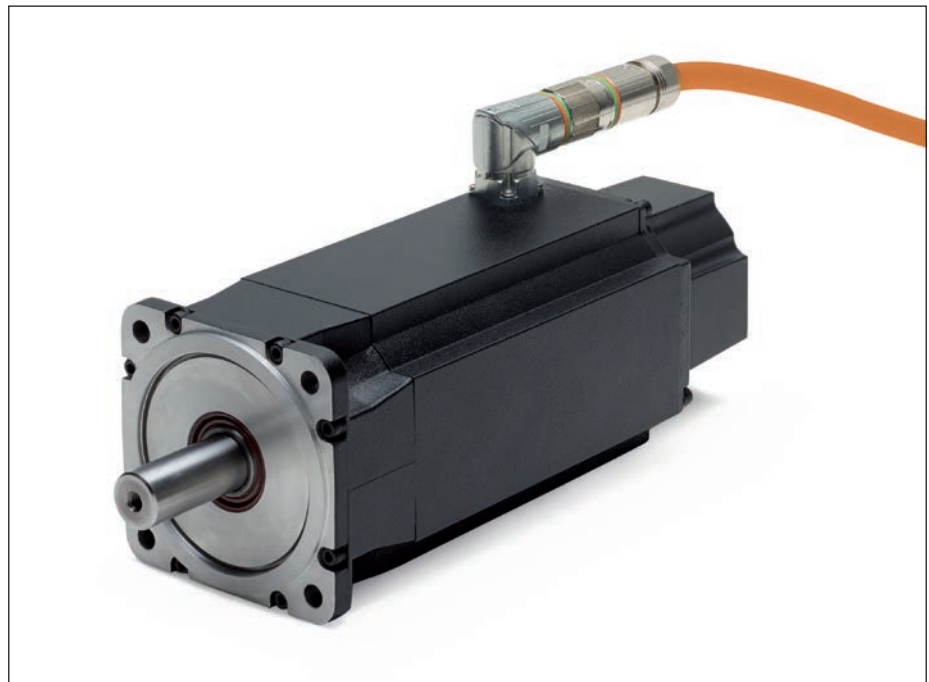
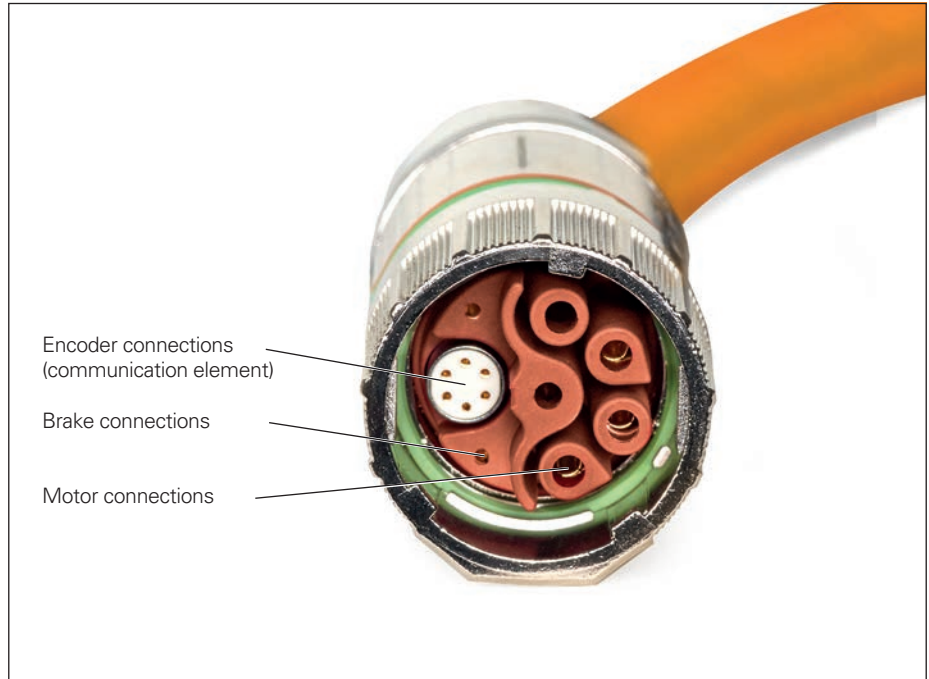

Advantages

The HMC 6 single-cable solution offers a series of cost and quality improvements that benefit both the motor manufacturer and the machine tool builder:

- Continued use of existing interfaces
- Potential for smaller drag chains
- Significant improvement in drag-chain suitability thanks to fewer cables
- Wide range of available encoders for HMC 6 transmission

- Reduced need for mechanical alterations (flange socket on the motor and cable ducts within the motor housing)
- Reduced logistical cost and effort for cables and connectors
- Simpler and speedier installation
- Reduced documentation effort
- Lower number of required components for servicing
- Lower motor profile with attached cable for easier integration into the machine enclosure
- HEIDENHAIN-tested power- and encoder-cable combination

The universal design of the HMC 6 gives you, the motor or machine manufacturer, utmost flexibility by allowing you to use standard components on both the motor and the control.

A particular advantage of the HMC 6 single-cable solution is its compatibility with **all HEIDENHAIN encoders that are equipped with the EnDat22 interface** or that are capable of purely serial data transmission without battery buffering in accordance with RS-485. These encoders include rotary encoders for servomotors in various sizes, as well as linear and angle encoders used in direct drives. Also compatible, of course, are encoders for **functional safety** up to SIL 3.

But there is no need for acrobatics on the control side either, because you can continue to use your already existing inverter systems or controller units. The HMC 6 cable has been designed for the easy assembly of the proper connecting elements. Most importantly, the noise immunity is not impaired.



Components

You need only a few components to get your motor ready for the single-cable solution.

Connecting element on the motor

The motor housing must be equipped with a special angle flange socket that gathers together the wires for the encoder, the motor power supply, and the brake.

Crimping tools for the power wires

The crimp contacts for the power and brake wires are assembled with the usual tools.

Output cable inside the motor housing

The rotary encoder is connected over the output cable inside the motor housing: your pre-assembled communication element is simply plugged into the angle flange socket.

Cable with hybrid connector

In addition to the encoder wires, the HMC 6 motor connecting cable also incorporates the power and brake wires. The cable is assembled to a hybrid connector on one end.

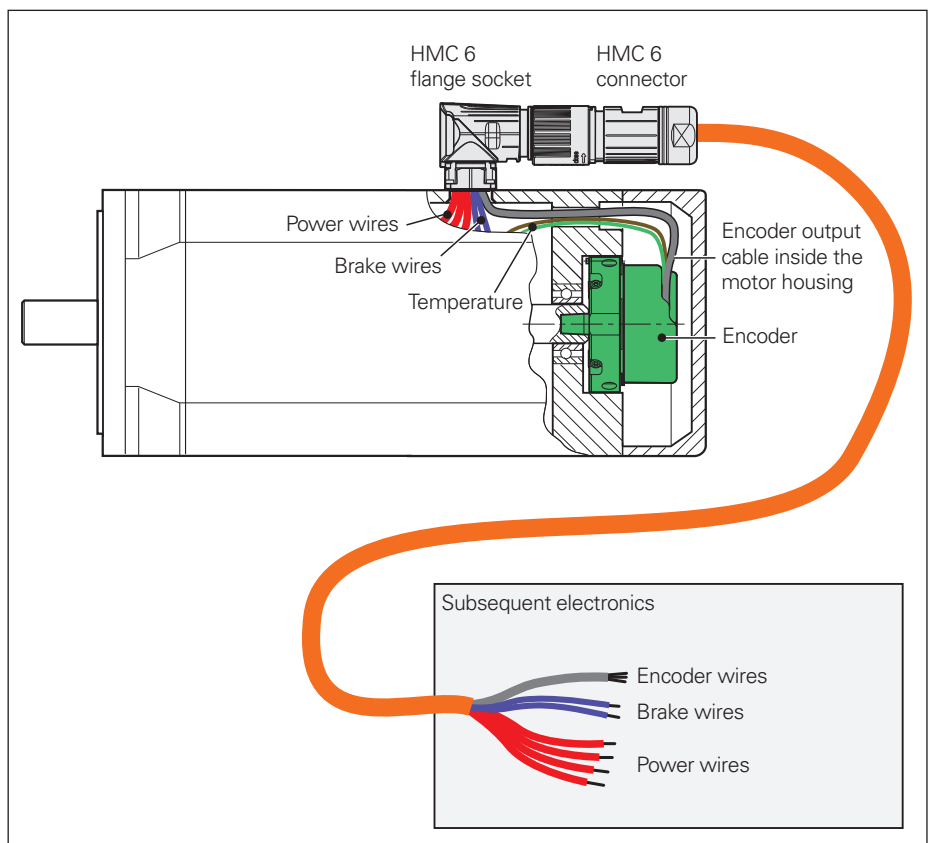

HMC 6

Components

Angle flange socket

A special angle flange socket is used for the electrical connection of the motor to the subsequent electronics. Inside the angle flange socket, the encoder wires (communication and power supply), the motor power wires, and the brake wires are all brought together.



Angle flange socket

Crimp contacts for the power wires are available with cross sections of up to 2.5 mm² and 4 mm². All versions feature an M23 outside thread for the connector.

The crimp contacts for the power and brake wires are included in the angle flange socket service pack. The encoder connections are simply plugged into the contact insert as a pre-assembled communication element. A protective cap is included for the threads of the flange socket. The angle flange socket and connector can be individually marked with colored rings for unambiguous identification. These colored rings are available from TE Connectivity.

Fastening hole circle	Ø 28 mm
Cross section: 2.5 mm ²	ID 1043027-01
Cross section: 4 mm ²	ID 1043027-03

For the required mating dimensions, please refer to the *Cables and Connectors* brochure.

Crimping tools

The contacts to be used in the angle flange socket for the power and brake wires are standard, commercially available crimp contacts. Their assembly requires the appropriate crimping tools and adjusting aids.

You can order these crimping tools directly from:

TE Connectivity Industrial GmbH
 Bernriederstraße 15
 94559 Niederwinkling, Germany
 Tel.: +49 9962 2002-0
 Fax: +49 9962 2002-70
 E-mail: intercontec@te.com
 Web: www.te.com

C0.236.00 digital crimping tool
 with C0.245.00 locator



C0.235.00 digital crimping tool
 with C0.265.00 locator



C0.201.00 manual crimping tool
 with C0.138.00 locator



Contacts and tools	Cross section	Order number		Crimping Tool	
		HEIDENHAIN	Intercontec	Crimping tool	Adjusting aid (locator)
Brake contacts	0.14 mm ² to 1.0 mm ²	1043266-01	61.253.11	C0.235.00	C0.265.00
	0.5 mm ² to 1.5 mm ²	1043266-02	61.221.11	C0.236.00	C0.245.00
Power contacts	0.35 mm ² to 2.5 mm ²	1043251-01	61.242.11	C0.235.00	C0.265.00
	2.5 mm ² to 4.0 mm ²	1043251-02	61.243.11	C0.201.00	C0.138.00

Output cable inside the motor housing

The output cables within the motor housing are pre-assembled. The PCB connector is connected to the rotary encoder, and the communication element is simply plugged into the angle flange socket. Output cables for inside the motor housing are available for most rotary encoders of the ECN/EQN/ECI/EQI 1100 and the ECN/EQN/ECI/EQI 1300 families. These cables are available either with or without wires for the connection of a temperature sensor located in the motor winding (cross section: 0.16 mm²).

For information on the temperature sensors that can be used, please refer to the *Encoders for Servo Drives* brochure.

Crimp connector

For joining (crimping) the wires of the temperature sensor output cable to the wires of the temperature sensor within the motor.

ID 1148157-01

Output cables inside the motor housing	ECN/EQN 11xx	ECI/EQI 11xx ECI 1xx	ECN/EQN 13xx ECI/EQI 13xx
Without temperature sensor wires	ID 1034953-xx	–	ID 1034913-xx
With temperature sensor wires	ID 1035857-xx	–	ID 1035387-xx
With temperature sensor wires and cable clamp for shield connection	–	ID 1072652-xx	–



Output cable for inside the motor housing, with PCB connector, temperature sensor wires, and communication element

Cable with hybrid connector

In addition to the encoder wires, the HMC 6 motor connecting cable also incorporates the power and brake wires. On one end, the cable is assembled to an M23 hybrid connector that fits the angle flange socket on the motor.

The HMC 6 cables are available with power wire cross sections of 1.5 mm² or 4 mm². The cable end for the inverter is unassembled.

For other cable lengths and larger quantities, please contact your sales agency.

Testing cable for PWM 2x

Cable length: 1 m
ID 1189174-01

Cables with hybrid connector	Power wires (cross section)	
	1.5 mm ²	4 mm ²
10 m	ID 1188098-10	ID 1188099-10
25 m	ID 1188098-25	ID 1188099-25
50 m	ID 1188098-50	ID 1188099-50

For information on wire cross sections, please refer to the *Cables and Connectors* brochure.



HMC 6

Components

Motor connecting cable

In some cases, you may need to assemble the motor connecting cable or an extension cable on your own, which is why you can also order the required components individually.

The hybrid connector and coupling are shipped as service packs containing the contact insert and all of the crimp contacts required for the power, brake, and encoder wires, as well as the communication element and a protective cap for the M23 thread of the coupling.

The hybrid cable is shipped in lengths of 10 m, 20 m, or 100 m as a bundle, or at a length of 1000 m on a drum.

Connecting elements*	Power wires (cross section)	
	1.5 mm ²	4 mm ²
Hybrid connector	ID 1075255-01	ID 1075255-02
Hybrid coupling	ID 1084549-01	ID 1084549-02



Hybrid connector



Hybrid coupling

Hybrid cable (unassembled)	Power wires (cross section)	
	1.5 mm ²	4 mm ²
Length		
10 m	ID 1188327-10	ID 1188328-10

* Available in stainless steel upon request

For the required mating dimensions, please refer to the *Cables and Connectors* brochure.

Tools for the communication element in the hybrid connector and coupling

In addition to the tools for crimping the power and brake contacts, other tools are required for assembly of the hybrid cable. In particular, these tools are needed for assembling the encoder wires and the communication element.

The tools for assembly of the communication element can be ordered directly from:

TE Connectivity Industrial GmbH
 Bernriederstraße 15
 94559 Niederwinkling, Germany
 Tel.: +49 9962 2002-0
 Fax: +49 9962 2002-70
 E-mail: intercontec@te.com
 Web: www.te.com

C0.235.00 digital crimping tool
 with C0.265.00 locator



C0.323.00 assembly tool
 with crimping and positioning insert



Tools	Cross section	Tool
For crimping the contacts for encoder wires	0.32 mm ² to 2.5 mm ²	C0.235.00 crimping tool with C0.265.00 locator
For crimping the shield for the communication element	–	C0.323.00 assembly tool and C0.321.00 crimp insert
For sliding on the locking sleeve for the communication element	–	C0.323.00 assembly tool and C6.166.00 positioning insert

Crimping tools

Crimp parameter settings (*non-binding information*)

Please comply with the current user's manual for crimping tools from TE Connectivity!

For contacts $\leq 2.5 \text{ mm}^2$

Type of contact		60.216.xx	60.270.xx	60.278.xx	61.221.xx	61.242.xx	61.252.xx	61.253.xx
Crimping tools with digital display		C0.236.00	C0.235.00		C0.236.00	C0.235.00		
Locator		C0.245.00	C0.265.00		C0.245.00	C0.265.00		
Locator setting		12	9	11	12	9	11	10
Wire cross section		Crimp dimension setting [in mm or specified as per MIL 22520]						
0.081 mm ²	AWG 28			0.48/H2			0.48/H2	0.56/H3
0.102 mm ²	AWG 27			0.48/H2			0.48/H2	0.65/H4
0.14 mm ²	AWG 26			0.48/H2			0.48/H2	0.65/H4
0.2 mm ²	AWG 24			0.56/H3			0.56/H3	0.74/H5
0.24 mm ²	AWG 23			0.56/H3			0.56/H3	0.74/H5
0.34 mm ²	AWG 22		0.90/-	0.65/H4		0.90/-	0.65/H4	0.84/H6
0.5 mm ²	AWG 20	0.81/F2	1.06/-		0.81/F2	1.06/-		0.84/H6
0.75 mm ²	AWG 19	0.81/F2	1.14/-		0.81/F2	1.14/-		0.94/H7
0.82 mm ²	AWG 18	0.81/F2	1.22/-		0.81/F2	1.22/-		0.94/H7
1.0 mm ²	AWG 17	0.91/F3	1.29/-		0.91/F3	1.29/-		1.04/H8
1.3 mm ²	AWG 16	0.91/F3	1.30/-		0.91/F3	1.30/-		
1.5 mm ²	AWG 15	0.99/F4	1.31/-		0.99/F4	1.31/-		
2.1 mm ²	AWG 14		1.33/-			1.33/-		
2.5 mm ²	AWG 13		1.34/-			1.34/-		

For contacts from 2.5 mm^2 to 4 mm^2

Type of contact		60.272.xx	61.243.xx
Hand crimping tool		C0.201.00	
Locator		C0.138.00	
Locator setting		Blue	Blue
Wire cross section		Tool setting	
2.1 mm ²	AWG 14	3	3
2.5 mm ²	-	4	4
3.3 mm ²	AWG 12	4	4
4.0 mm ²	-	5	5

Green fields: Settings required for HEIDENHAIN connecting cables

Gray fields: Possible settings for motor connection wires

Date of table: October 2014

General electrical information

Use of the hybrid cable is subject to the general electrical information in the *Interfaces of HEIDENHAIN Encoders* brochure.

Please also note the following:

- **Shielding** must be implemented in accordance with the grounding diagram.
- Unneeded **brake wires** must be grounded on the power module.
- The **air clearance** between the stripped power wires and brake wires, and between the stripped power wires and encoder wires, must comply with at least the basic insulation (based on the working voltage of the U/V/W power module).
- The shield of the power wire bundle must be folded back over the protective jacket of the connecting cable. The shield must also be shortened and connected to protective earth (PE).
- The temperature range of the output cable within the motor is -20 °C to 120 °C (at rest).

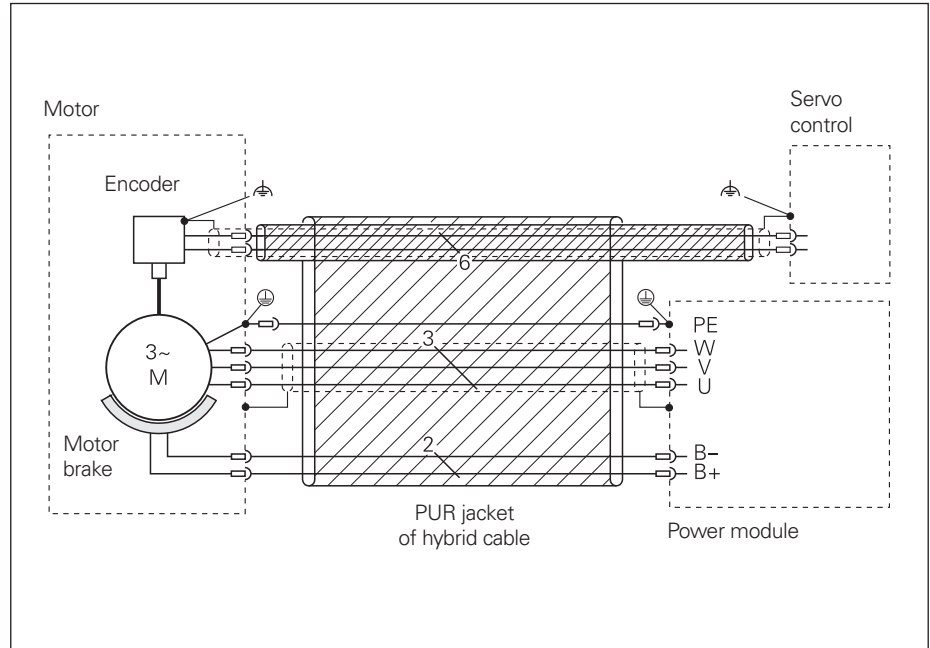

Grounding diagram

- The **NRTL certification** is documented by the label "AWM STYLE 20235 80 °C Voltage not specified E63216"
- The hybrid cable is **suitable for use with a drag chain** for up to at least 5 000 000 cycles at a bend radius of seven times the cable diameter.
- The **ampacity** of the hybrid cable complies with VDE 0891 Part 1.
- **Cable lengths** of up to 100 m are permitted, as are clock frequencies in accordance with the EnDat specifications (see the *Interfaces of HEIDENHAIN Encoders* brochure).

Area of application as per EN 61800-5-1 / UL 20235

	Power wires	Encoder wires and brake wires
System voltage	300 V	50 V
Voltage class	C	
Working (nominal) voltage	1000 V EN 61800-5-1 600 V UL 20235	50 V EN 61800-5-1 30 V UL 20235
Overvoltage category	III	II

Bend radius

	Diameter	Jacket	Bend radius R	
			Rigid routing	Frequent flexing
Cables with hybrid connector	Ø 13.6 mm	PUR	≥ 50 mm	≥ 80 mm
	Ø 16.6 mm	PUR	≥ 65 mm	≥ 110 mm
Output cable inside the motor housing	Ø 3.7 mm	EPG	≥ 10 mm	–

Electrical connection

Pin layout

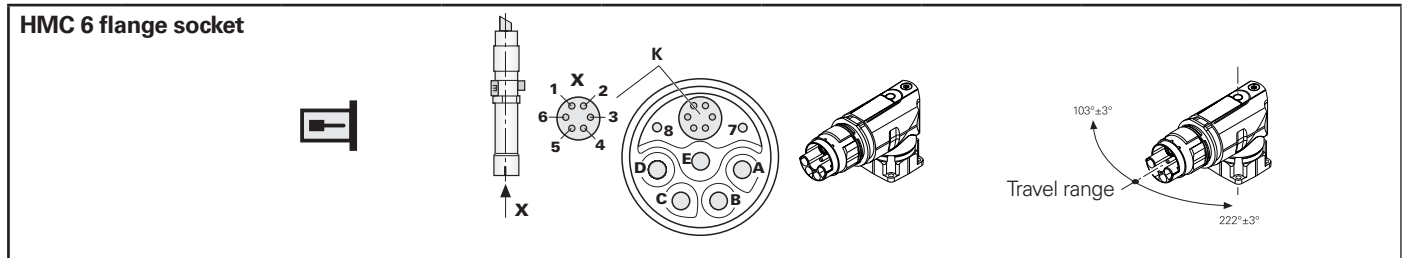

Encoder								
	Power supply		Serial data transmission				Other signals	
	1	2	3	4	5	6	/	/
16	1b	4b	6b	1a	2b	5a	8a	8b
15	13	14	7	8	9	10	5	6
	U_P	0V	DATA	DATA	CLOCK	CLOCK	T⁺¹⁾	T⁻¹⁾
	Brown/Green	White/Green	Gray	Pink	Violet	Yellow	Brown	Green

Motor							
	Brake		Power				
	7	8	A	B	C	D	E
	BRAKE-	BRAKE+	U	V	W	/	PE
	White	White/Black	Blue	Brown	Black	/	Yellow/ Green

External shield of the encoder output cable on communication element housing **K**.

Unused pins or wires must not be assigned!

¹⁾ For the connection of a temperature sensor, see the encoder's documentation.

Conformity with the EMC Directive must be ensured for the complete system!

HEIDENHAIN

DR. JOHANNES HEIDENHAIN GmbH

Dr.-Johannes-Heidenhain-Straße 5

83301 Traunreut, Germany

☎ +49 8669 31-0

FAX +49 8669 32-5061

info@heidenhain.de

www.heidenhain.com

This Product Information document supersedes all previous editions, which thereby become invalid. The basis for ordering from HEIDENHAIN is always the Product Information document edition valid when the order is made.



More information:

Comply with the requirements described in the following documents to ensure correct and intended operation:

- Brochure: *Cables and Connectors* 1206103-xx
- Brochure: *Encoders for Servo Drives* 208922-xx
- Brochure: *Interfaces of HEIDENHAIN Encoders* 1078628-xx

For brochures and Product Information documents, visit www.heidenhain.de.