



HEIDENHAIN



Product Information

EIB 5000

Signal Converters for
Temperature Measurement
in Direct-Drive Motors

HEIDENHAIN EIB 5000 signal converters

Signal converters for temperature measurement in direct-drive motors

- Reduced cabling
- Overload protection of the direct-drive motor through monitoring of all three windings
- Faster response behavior to overheating through compensation of the transmission timing behavior of the temperature measurement (for direct-drive motors from ETEL)
- More economical use of the direct-drive motor through operation up to its thermal load limit
- Suitability for various encoder interfaces and control platforms

Application

The HEIDENHAIN EIB 5000 series signal converters enable measurement of the temperature in direct-drive motors. To do so, the EIB 5000 units process values from up to three temperature sensors and compensate for the transmission timing behavior of the temperature measurement (for direct-drive motors from ETEL). The maximum determined temperature is relayed to the upstream control. When the sensor box is used with a HEIDENHAIN encoder, the processed temperature values can be transmitted to the upstream control along with the position data. The control can use the temperature values to optimize the regulation of the direct-drive motor, thus ensuring a rapid shutoff in case of an overload.

The compensation of the transmission timing behavior of the temperature measurement is optimized for direct-drive motors from ETEL. The EIB 5000 can be operated together with direct-drive motors from other manufacturers as well. Please contact HEIDENHAIN for more information.

EIB 5000 series

The EIB 5000 series includes variants designed for mounting in an electrical cabinet (IP20) as well as for close-to-application temperature measurement of a direct drive motor (IP65/67).

The **EIB 5181** is optimized for use in an electrical cabinet in combination with controls from HEIDENHAIN. The placement in an electrical cabinet makes it possible to use DIP switches in order to configure the necessary parameters. Also, the EIB 5181 offers a universal interface solution for encoders with 1 V_{PP} EnDat 2.1, and EnDat 2.2 interfaces. The encoders must be connected to the encoder input using a 25-pin D-sub connector, since the EIB transmits the temperature value to the control as an analog value.

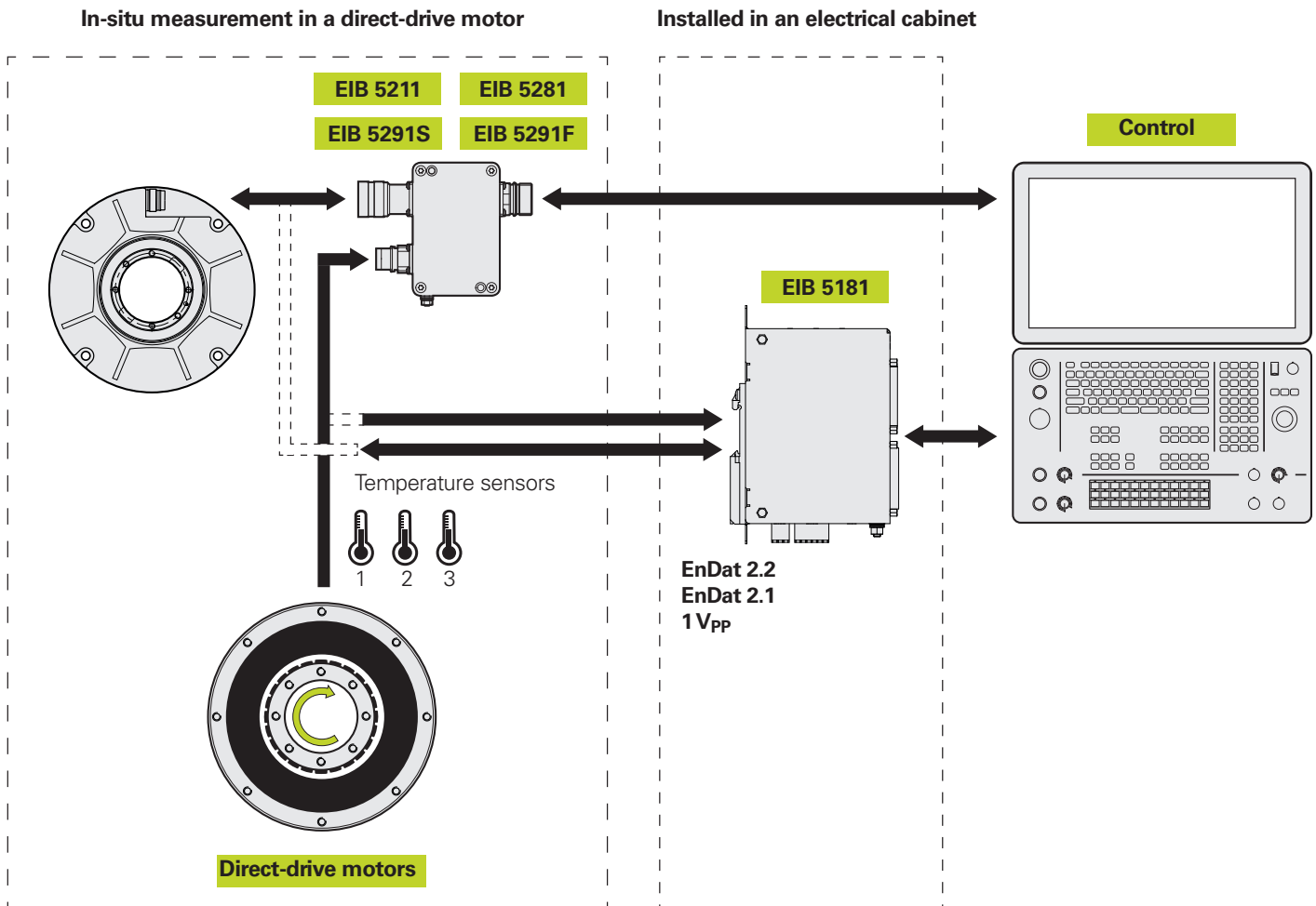

The **EIB 5281** is primarily designed for encoders with the EnDat 2.1 interface in conjunction with HEIDENHAIN controls. The EIB transmits the temperature to the control as an analog value (PT 1000 emulation) along with the information about the interface, which is determined by the encoder itself. Thanks to the IP65/67 rating, the EIB 5281 can be placed in direct proximity to the direct drive motor. This makes it possible to keep the length of the connecting cables for the temperature sensors very short. Depending on the type of direct-drive motor, a special variant of the EIB 5281 may be required (see *Variants of the EIB 5200*). The EIB 5281 can also be obtained with an additional switching output (see *Switching outputs*). Please contact HEIDENHAIN for more information.

The **EIB 5211** is primarily designed for encoders with the EnDat 2.2 interface. The temperature value is transmitted to the control digitally in the protocol (if the interface supports this). The EIB 5211 itself does not influence the encoder interface. Not only does the EIB 5211 have a high IP65/67 rating, but its purely digital data transmission offers numerous important advantages as well. The transmission technology is particularly immune to noise and achieves an increased accuracy of the temperature evaluation (also see *Emulation of PT 1000 behavior*). Depending on the type of direct-drive motor, a special variant of the EIB 5211 may be required (see *Variants of the EIB 5200*). The EIB 5211 can also be obtained with an additional switching output (see *Switching outputs*). Please contact HEIDENHAIN for more information.

The digitized temperature value is transmitted from the EIB 5211 to the encoder, and then from the encoder over the interface to the control. The encoder must have been appropriately designed for this type of operation. Suitable at present are the RCN 2001, RCN 5001, and RCN 8001 series. Please contact HEIDENHAIN for information about the availability of other encoders.

The **EIB 5291 S and EIB 5291 F** combine the functionality of the EIB 5211 with the direct connectivity to downstream electronics with the DRIVE-CLiQ or Fanuc interface. For this purpose the two EIB units have an integrated function for converting from EnDat 2.2 to DRIVE-CLiQ or Fanuc. Accordingly, an encoder with the ordering designation EnDat 22 must be used. Regarding the temperature evaluation and possibilities for connection, it is the same as the EIB 5211.

Switching outputs

The EIB 5282 and EIB 5212 have additional switching outputs. This makes it possible, for example, to switch off the direct-drive motor via the PLC if the temperature signal cannot be processed directly by the downstream electronics. Two switching outputs are supported:

- Error (temperature > 130 °C)*
- Warning (temperature > 100 °C)*
- Supply voltage (PELV¹⁾): 0 V to 36 V
- Switching capacity: max. 32 mW
- 4-pin M12 flange socket (male)
- Cable length: max. 20 m

For more information, please contact HEIDENHAIN.

Using the EIB 5281 or EIB 5211 with other controls

The EIB 5281 and EIB 5211 do not influence the encoder interface. This means that the interface is determined by the connected encoder, and not by the EIB. Not all controls or interfaces permit transmission of the temperature values, so in these cases the direct-drive motor cannot be switched off based on the temperature value. However, with the additional switching outputs, the EIB 5282 and EIB 5212 can still be used for effective switch-off of the direct-drive motor. In conjunction with the switching outputs, the EIB 5282 and EIB 5212 can thus be used with encoders or controls featuring the Fanuc, Mitsubishi, Panasonic, or Yaskawa interfaces. With the Fanuc interface, the temperature values can be transmitted via the interface for display or diagnostic purposes. Using the transmitted temperature is recommended here for switch-off of the direct-drive motor, or as an alternative, the EIB 5212 with integrated switching outputs. For more information, please contact HEIDENHAIN.

* Default setting; please contact HEIDENHAIN regarding the availability of other switch-off thresholds.

¹⁾ For the PELV definition, see *General electrical information* in the *Interfaces of HEIDENHAIN Encoders* brochure

DRIVE-CLiQ is a registered trademark of Siemens AG

Variants of the EIB 5200

An appropriate variant of the EIB 5200 may be needed depending on the direct-drive motor. Before delivery, the variant is programmed for a particular combination of the following factors:

- Configuration of the temperature sensors
- Compensation value of the transmission timing behavior regarding the temperature measurement

Temperature sensors

The EIB 5000 enables simultaneous evaluation of up to three temperature sensors. The following sensor types can be evaluated:

- PT 1000
- PTC¹⁾
- PTC triplet¹⁾
- KTY 84-130²⁾

Temperature evaluation

Based on data from the sensors, the highest temperature value is determined, and the transmission timing behavior of the temperature measurement is compensated for (for ETEL direct-drive motors). The resulting value is then relayed to the control. In this process, the sensor values are digitized, calculations are performed, and the determined value is converted into an equivalent analog output signal. This signal can be evaluated by the control's temperature input. With the EIB 5211 there is no conversion to analog signals. The digitally determined value is transmitted directly via the purely serial EnDat 2.2 or Fanuc interface. The evaluation of all three winding temperatures, as opposed to the evaluation of only one temperature sensor or PTC triplet sensor, offers significant advantages in the application and increases the cost-efficiency:

- Overload protection of the direct-drive motor through monitoring of all three windings
- Faster response behavior to overheating through compensation of the transmission timing behavior of the temperature measurement (for direct-drive motors from ETEL)
- More economical use of the direct-drive motor through operation up to its thermal load limit

¹⁾ In cold state a temperature of 10 °C is output.
In switched state:
EIB 5181, EIB 5281 200 °C
EIB 521x 250 °C
EIB 5291 F 223 °C
EIB 5291 S 250 °C (if configured for the PTC, otherwise -300 °C)

²⁾ Singly, or, in the case of multiple sensors, with shared signal reference at the cathode

Compensation of the transmission timing behavior of the temperature measurement for direct-drive motors from ETEL

When a direct-drive motor is required to hold a position at standstill, an asymmetric current distribution may arise. This can cause a winding to overload and lead to a rapid spike in temperature. The simplest way of detecting such an overload is through the use of three switching elements (usually PTC thermistors).

However, because the measurement location and the affected components are thermally decoupled from each other, the winding may become overheated before the switching elements react. When sensors are used instead of switching elements, and when the thermal coupling is known (thermal model), the sudden spike in temperature can be emulated through mathematical compensation of the transmission timing behavior of the temperature measurement. Switch-off occurs much earlier, thereby contributing significantly to protection of the direct-drive motor. The transmission timing behavior of the temperature measurement is largely determined by the thermal coupling between the sensor and the motor winding, and by the design of the direct-drive motor. Different types of direct-drive motors exhibit different time constants. For ETEL direct-drive motors, the exact time constants are known. On the EIB 5181 the time constant can be set using the DIP switches. For the EIB 5200 the time constant must be indicated when ordering.

Emulation of PT 1000 behavior

At the control input, the EIB 5181 and EIB 528x emulate the resistance value of a PT 1000 sensor. In determining the temperature value, the control must provide a constant level of current to ensure correct emulation and proper functioning of the control algorithms. The temperature value is then determined through the drop in voltage. If a pulsed current is injected, then proper functioning cannot be guaranteed (e.g., with the SMx sensor module from Siemens). The accuracy of the temperature evaluation is also affected by the cable length. The EIB 5181 also emulates the behavior of a PT 1000, but additionally the DIP switches can be used to reconfigure it to emulate a KTY84-130.

Electrical safety

The EIB 5000 features increased insulation separating the motor sensor inputs from the encoder and control connections. The EIB 5000 temperature sensor inputs exhibit safe electrical separation from dangerous electric circuits in accordance with DIN EN 61010-1 and DIN EN 61800-5-1. This ensures effective protection of the downstream electronics.

Cascading

In certain applications (e.g., gantry motors), two direct-drive motors may be controlled by means of a single encoder. To enable temperature monitoring in both direct-drive motors, two EIB sensor boxes can be used in combination. The two sensor boxes must be properly configured (please contact HEIDENHAIN). The EIB 5181 is configured using DIP switches. Cascading is not possible with the EIB 521x, EIB 5291 S or EIB 5291 F.

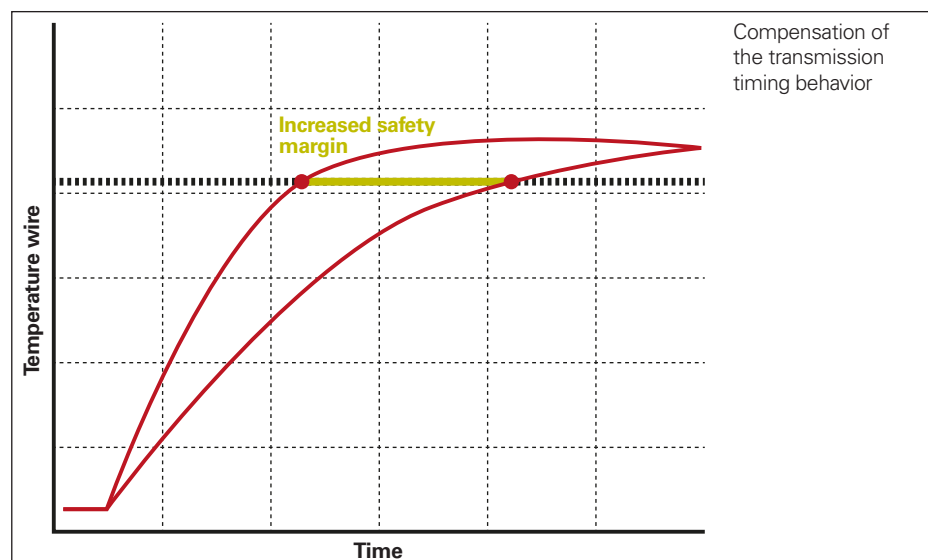



Monitoring functions

The EIB 5000 uses its analog temperature connection and/or the digital temperature value to output not only the temperature but fault conditions as well:

- Sensor short
- Sensor wire breakage
- Invalid configuration
- Other errors

Power-on behavior

During the initialization phase, the maximum value is output for the temperature. The temperature value then levels out at the actual measured value.

Power supply

The supply voltage from the downstream electronics is passed to the connected encoder via the EIB. The power required for evaluation of the temperature sensors is diverted from the incoming supply voltage by means of galvanic isolation.

EIB 5291 S: As opposed to other EIB 5000 units, here the supply voltage for the encoder and also for the EIB 5291 S is generated from the 24 V.

Functional safety

The EIB can be used in safety-related applications only if functional safety is supported by the connected encoder. The characteristics pertaining to functional safety are largely determined by the connected encoder and the downstream electronics (if required, contact the manufacturer; the EIB relays the main characteristics of the encoder). The **safe position** is also largely determined by the connected encoder and the downstream electronics.

Functional safety (EIB 5291 S)

Additionally true for the EIB 5291 S: The EIB itself does not influence the safe position. The "safe position" and "safety-related measuring step (SM)" of the connected EnDat encoder are required in order for the safe position to be calculated. For more information, please contact the manufacturer of the downstream electronics. The PFH value of the overall system (EIB 5291 S + encoder) is the sum of the PFH values of the EIB 5291 S and the connected encoder. For information about the encoder, please refer to its documentation (Product

Information document, brochure, and mounting instructions). The EIB 5291 S is designed for a service life of 20 years (in accordance with ISO 13849). For more information about using the EIB and the encoder in safety-related applications, please contact the manufacturer of the downstream electronics.

After installing and exchanging the encoder, perform an acceptance test of the machine in accordance with the specifications of the manufacturer. Encoders that have contributed to the failure of a safety function in the application must be returned to HEIDENHAIN Traunreut.



Note:

In order for the EIB 5291 S to be operated in safety-related applications, the software must be designed in conformity with the downstream electronics with the DRIVE-CLiQ interface. For more information on availability, please contact the manufacturer. Pay attention to the information provided by the control manufacturer regarding its operation in safety-related applications.

EIB 5291 S

Functional safety	Depending on the connected encoder and downstream electronics, suitable for applications with up to: <ul style="list-style-type: none"> • SIL 2 as per EN 61508 (further basis for testing: EN 61800-5-2) • Category 3, PL d as per EN ISO 13849-1:2015
PFH	$26 \cdot 10^{-9}$ (with respect to an operating elevation of ≤ 1000 m above sea level)



Combination of an RCN encoder and an EIB 521x signal converter

EIB 5281

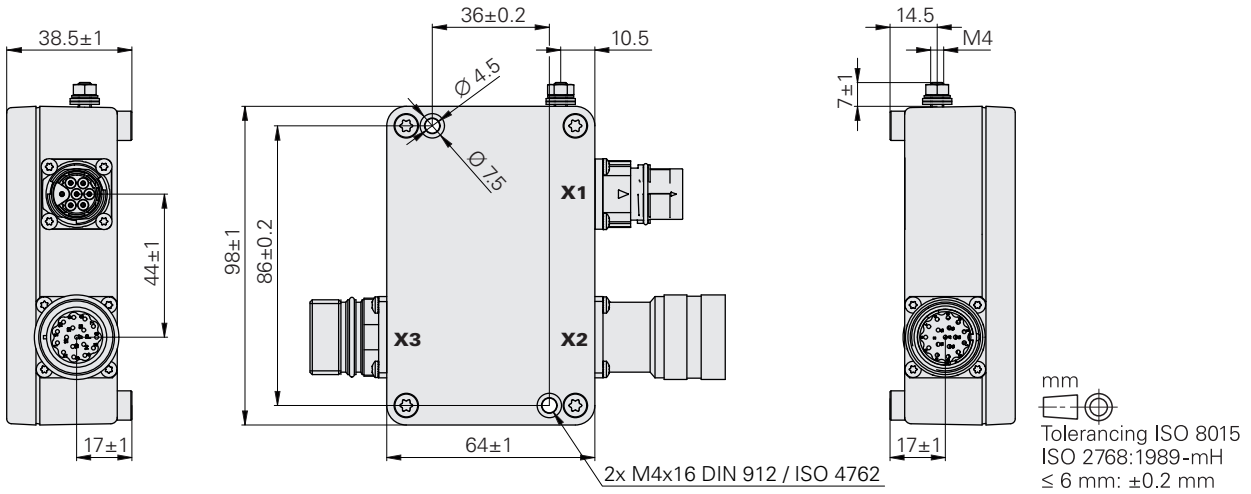

EIB 5282

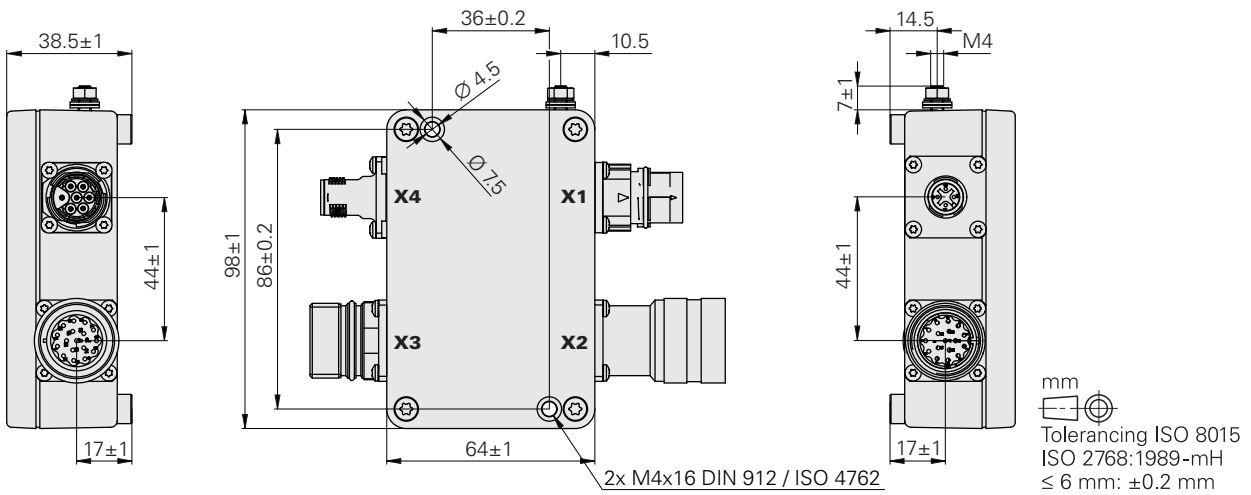

EIB 5181

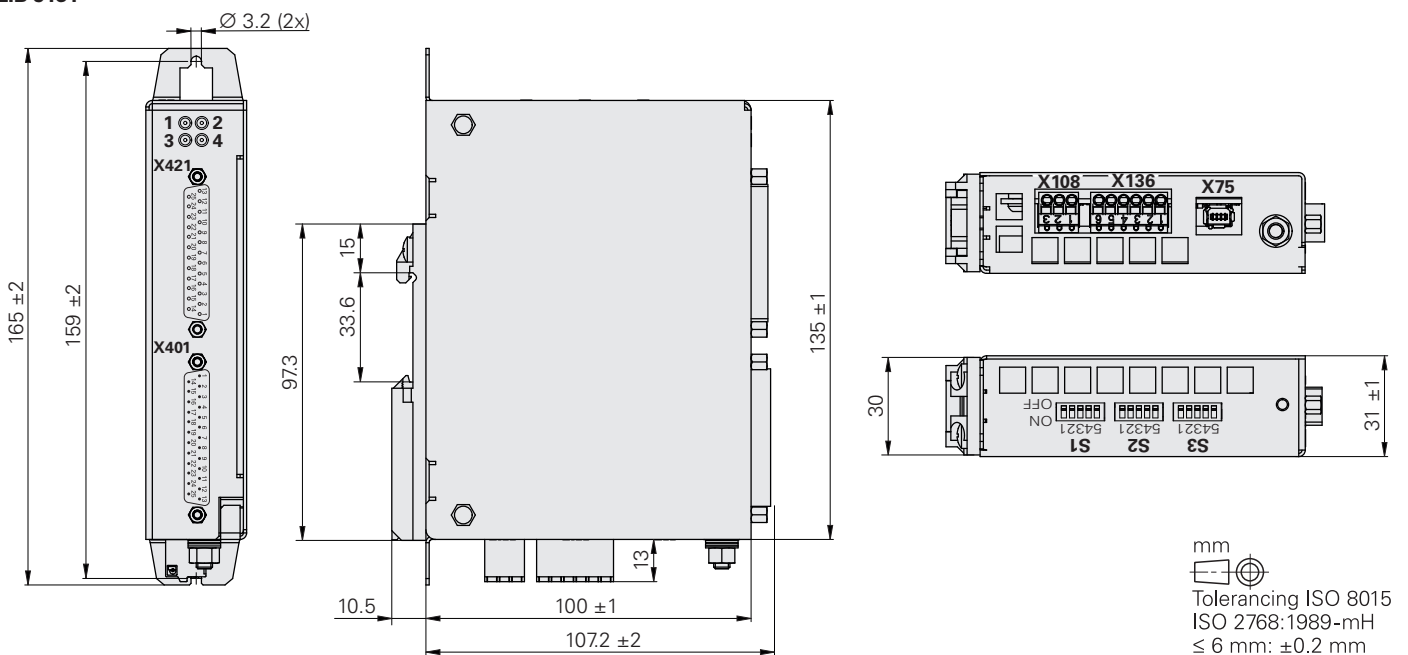

Specifications	EIB 5281/EIB 5282 ¹⁾	EIB 5181
Functional safety	See <i>Functional safety</i> on page 5	
Encoder input		
Interface	Depends on the encoder ²⁾	1 V _{PP} /EnDat 2.1/EnDat 2.2
Ordering designation	Depends on the encoder ²⁾	EnDat01/EnDat02/EnDat22
Electrical connection	17-pin M23 flange socket (female) with coupling ring	25-pin D-sub connector (male)
Power supply of encoder	The supply voltage from the downstream electronics is relayed to the connected encoder via the EIB	
Cable length ³⁾	< 6 m	< 100 m
Temperature sensor input		
Quantity	3	
Connectable sensors ⁴⁾	KTY 84-130, PT 1000, PTC, PTC triplet ⁵⁾	
Evaluation accuracy tolerance	Typically: ±1 K; maximum: ±2 K	
Time constant for temperature measurement	Please indicate when ordering	Set using DIP switches
Electrical connection	7-pin M17 flange socket (female)	6-pin header (male)
Cable length ⁶⁾	< 6 m	< 45 m (for the KTY 84-130 and a conductor cross section of 0.25 mm ²)
Control output		
Interface	Depends on the encoder ²⁾	1 V _{PP} /EnDat 2.1/EnDat 2.2
Ordering designation	Depends on the encoder ²⁾	EnDat01/EnDat02/EnDat22
Electrical connection	17-pin M23 flange socket (male)	25-pin D-sub connector (female)
Cable length ³⁾	< 50 m	< 3 m
Supply voltage ⁷⁾	5 V ±10 %	5 V ±10 %
Power consumption ⁸⁾	Typically: 200 mW; max. 300 mW	Typically: 250 mW; max. 350 mW
Temperature output	Emulation of PT 1000 behavior ⁹⁾	Emulation of PT 1000 or KTY84-130 behavior ⁹⁾
Emulation accuracy tolerance ¹⁰⁾	Typically: ±3 K; maximum: ±4 K	Typically: ±3 K; maximum: ±4 K
Operating temperature	0 °C to 70 °C ¹¹⁾	0 °C to 40 °C ¹¹⁾
Storage temperature	-30 °C to 70 °C ¹¹⁾	
Vibration 55 Hz to 2000 Hz Shock 11 ms	100 m/s ² (EN 60068-2-6) 300 m/s ² (EN 60068-2-27)	10 m/s ² (EN 60068-2-6) 30 m/s ² (EN 60068-2-27)
Protection EN 60529	IP65/67 (when engaged)	IP20
Elevation	< 2000 m above sea level	
Mass	≈ 0.5 kg	

¹⁾ The EIB 5282 features additional switching outputs (see *Switching outputs* on page 3)

²⁾ Optimized for EnDat 2.1, determined by the encoder and relayed by the EIB (see also *Using with other controls* on page 3)

³⁾ Applies only to HEIDENHAIN cables; be sure to consider the voltage drop

⁴⁾ For more information, see *Temperature evaluation and Monitoring functions*

⁵⁾ Please select when ordering; the EIB 5181 is configured using DIP switches

⁶⁾ Depends on the expected accuracy, sensor type and conductor cross section; observe any additional information from the motor manufacturer

⁷⁾ Take the supply voltage range of the encoder into account

⁸⁾ Without power or current consumption of the encoder; version with switching output: additional power consumption of 50 mW

⁹⁾ See *Emulation of PT 1000 behavior*

¹⁰⁾ Applies to a cable length < 1 m

¹¹⁾ No condensation; max. humidity of 75 % under continuous operation

EIB 5211/EIB 5291S/EIB 5291F

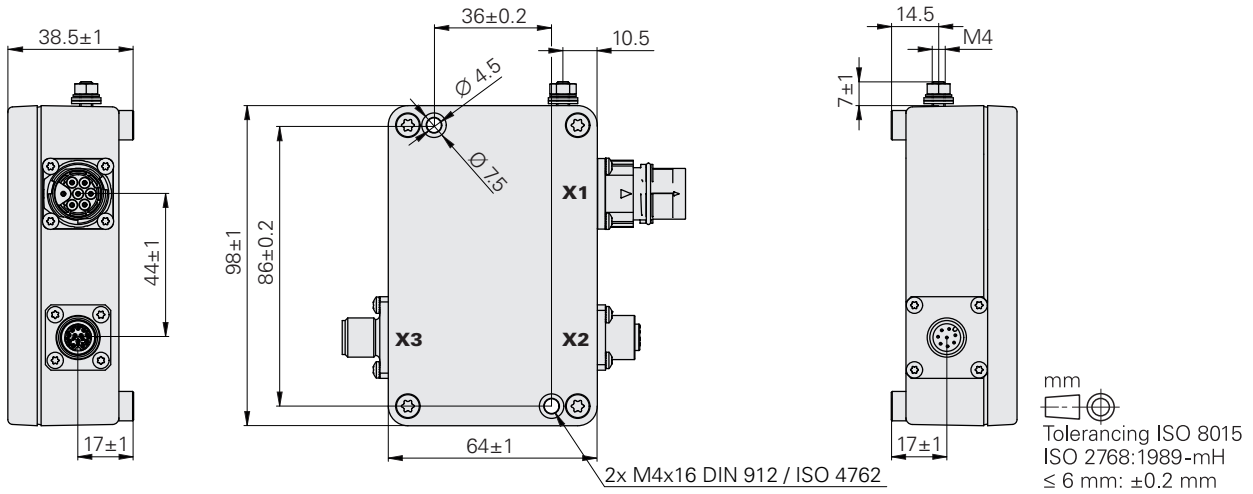

EIB 5212

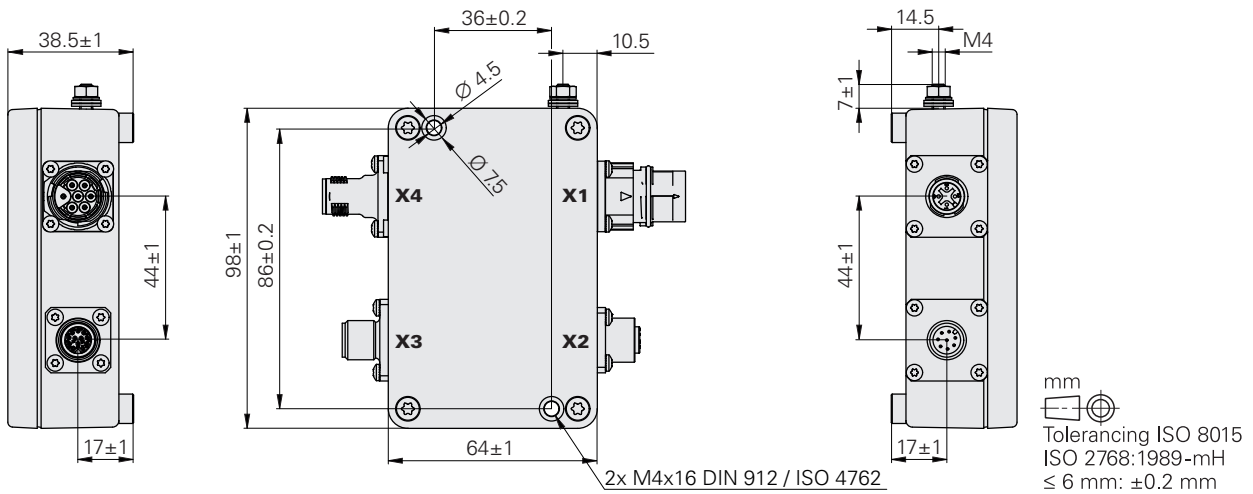

Further information:

For detailed descriptions of cables, please refer to the *Cables and Connectors* brochure.

Specifications	EIB 5211/5212 ¹⁾	EIB 5291 F	EIB 5291 S
Functional safety	See <i>Functional safety</i> on page 5		
Encoder input			
Interface	Depends on the encoder ²⁾		
Ordering designation	Depends on the encoder ^{2) 3)}	EnDat22 ³⁾	EnDat22 ³⁾
Electrical connection	12-pin M12 flange socket (female)		
Power supply of encoder	See <i>Power supply</i> on page 5		DC 8.0 V ±0.4 V (max. 1800 mW)
Cable length ⁴⁾	< 6 m		
Temperature sensor input			
Quantity	3		
Connectable sensors ⁵⁾	KTY 84-130, PT 1000, PTC, PTC triplet ⁶⁾		
Evaluation accuracy tolerance	Typically: ±1 K; maximum: ±2 K		
Time constant for temperature measurement	Please indicate when ordering		
Electrical connection	7-pin M17 flange socket (female)		
Cable length ⁷⁾	< 6 m		
Control output			
Interface	Depends on the encoder ²⁾	Fanuc	DRIVE-CLiQ
Ordering designation	Depends on the encoder ²⁾	Fanuc05	DQ01
Electrical connection	8-pin M12 flange socket (male)		
Cable length ⁴⁾	< 100 m	< 30 m	< 95 m
Supply voltage ⁸⁾	3.6 V to 14 V		DC 24 V (16.0 V to 28.8 V); up to DC 36.0 V possible without compromising functional safety
Power consumption	Typically: 160 mW; max. 210 mW ⁹⁾	Typically: 750 mW; max. 1000 mW ⁹⁾	Maximum At 16.0 V: ≤ 3300 mW At 28.8 V: ≤ 3400 mW Typically At 24.0 V: ≤ 1100 mW + 1.15 · P _{Mtyp} (P _{Mtyp} = Typical power consumption of the encoder)
Operating temperature	0 °C to 70 °C ¹⁰⁾		0 °C to 60 °C ¹⁰⁾
Storage temperature	-30 °C to 70 °C ¹⁰⁾		
Vibration 55 Hz to 2000 Hz Shock 11 ms	100 m/s ² (EN 60068-2-6) 300 m/s ² (EN 60068-2-27)		
Protection EN 60529	IP65/67 (when engaged)		
Elevation	< 2000 m above sea level		< 1000 m above sea level
Mass	≈ 0.5 kg		

¹⁾ The EIB 5212 features additional switching outputs (see *Switching outputs* on page 3)
²⁾ Optimized for EnDat 2.2, determined by the encoder and relayed by the EIB (see also *Using with other controls* on page 3)
³⁾ The encoder must be designed for connection of the EIB 521x or the EIB 5291 S
⁴⁾ Applies only to HEIDENHAIN cables; be sure to consider the voltage drop

⁵⁾ For further information, please refer to *Temperature evaluation and Monitoring functions*
⁶⁾ Please select when ordering
⁷⁾ Observe the information from the motor manufacturer
⁸⁾ Take the supply voltage range of the encoder into account
⁹⁾ Without power or current consumption of the encoder (version with switching output: additional power consumption of 50 mW)
¹⁰⁾ No condensation; max. 75% humidity in continuous operation

Directives and standards

Directives

The EIB 5000 meets the requirements of the following directives:

EU

2006/42/EC (EIB 5291 S only)

2014/30/EU

2011/65/EU

UK

SI 2008 No. 1597 (EIB 5291 S only)

SI 2016 No. 1091

SI 2012 No. 3032

Standards

Emission

EIB 5181 EN 50370-1

EIB 52xx EN 61000-6-4

Immunity

EIB 5181 EN 50370-2

EIB 52xx EN 61000-6-2

EIB 5291 S additionally EN 61800-5-2

Product standard for adjustable speed electrical power drive systems
EN 61800-5-1

Standard for electrical equipment for measurement
EN 61010-1

NRTL

UL 61010-1

CAN/CSA-C22.2 No. 61010-1

HEIDENHAIN

DR. JOHANNES HEIDENHAIN GmbH

Dr.-Johannes-Heidenhain-Straße 5

83301 Traunreut, Germany

☎ +49 8669 31-0

☎ +49 8669 32-5061

info@heidenhain.de

www.heidenhain.com

This Product Information document supersedes all previous editions, which thereby become invalid. The basis for ordering from HEIDENHAIN is always the Product Information document edition valid when the order is placed.



Further information:

To ensure proper and intended use, comply with the specifications in the following documents:

- Brochure, Product Information, and Mounting Instructions of the connected encoder
- Technical Information: *Safety-Related Position Measuring Systems* 596632-xx
- Operating Instructions: *EIB 518x, EIB 521x, EIB 528x, EIB 528x, EIB 5291 F* 1386382-xx
- Operating Instructions: *EIB 5291 S* 1390004-xx
- Installation Instructions: *EIB 5000* 1386395-xx