



HEIDENHAIN



EIB 5000

Installation Instructions

Table of contents

1	Fundamentals.....	5
2	Safety.....	10
3	Transport and Storage.....	14
4	Mounting.....	16
5	Installation.....	18
6	Servicing and Maintenance.....	32
7	What to do if	34
8	Removal and Disposal.....	36

1	Fundamentals.....	5
1.1	About these instructions.....	6
1.2	Information on the model.....	6
1.3	Notes on reading this document.....	7
1.4	Validity of the documentation.....	7
1.5	Storage and distribution of the documentation.....	8
1.6	Target group for the instructions.....	8
1.7	Notes in this documentation.....	8
1.8	Symbols and fonts used for marking text.....	9
2	Safety.....	10
2.1	Overview.....	10
2.2	Intended use.....	10
2.3	Improper use.....	10
2.4	Personnel qualification.....	10
2.5	Obligations of the operating company.....	11
2.6	General safety precautions.....	11
2.6.1	Electrical safety and voltage supply.....	12
2.6.2	Electrical safety precautions.....	12
3	Transport and Storage.....	14
3.1	Unpacking.....	14
3.2	Items supplied and accessories.....	14
3.2.1	Items supplied.....	14
3.2.2	Accessories.....	14
3.3	In case of damage in transit.....	14
3.4	Repackaging and storage.....	15
3.4.1	Repackaging the device.....	15
3.4.2	Storage of the device.....	15

4	Mounting.....	16
4.1	Overview.....	16
4.2	Mounting the EIB 5000.....	16
4.2.1	EIB 5181.....	16
4.2.2	EIB 52xx.....	17
5	Installation.....	18
5.1	General information.....	18
5.2	Product overview.....	19
5.3	Pin layout.....	21
5.4	Connecting the temperature sensors.....	26
5.5	Connecting the encoder.....	26
5.6	Connecting the control unit.....	27
5.7	Connecting the switching output (optional).....	27
5.8	Connecting functional ground (EIB 52xx).....	27
5.9	Connecting protective ground (EIB 5181).....	27
5.10	Connecting the shield of the sensor.....	28
5.11	DIP switch.....	28
5.12	LED display of EIB 5181.....	30
5.13	Cascading the EIB 5181.....	31
6	Servicing and Maintenance.....	32
6.1	Cleaning.....	32
6.2	Maintenance schedule.....	33
7	What to do if	34
8	Removal and Disposal.....	36
8.1	Removal.....	36
8.2	Disposal.....	36

1

Fundamentals

1.1 About these instructions

These instructions provide all the information and safety precautions needed for the proper mounting and installation of the device.



In addition to the information provided in the following, the general electrical information in the **Interfaces of HEIDENHAIN Encoders** brochure from HEIDENHAIN applies to the connection of the encoder.

- ▶ www.heidenhain.com/documentation
- ▶ Enter the document ID **1078628**

1.2 Information on the model

Product designation	ID	Configurable	Switching outputs
EIB 5181	1231387-xx	✓	
EIB 5211	1296676-xx		
EIB 5212	1264480-xx		✓
EIB 5281	1281777-xx		
EIB 5282	1296675-xx		✓
EIB 5291S*)	1334716-xx		
EIB 5291F	1391450-xx		

*) DRIVE-CLiQ is a registered trademark of SIEMENS Aktiengesellschaft.

ID label

The ID label is provided on the side panel of the product.

Example:



- 1 Product designation
- 2 ID number

CE mark

The product is CE-marked in accordance with EMC Directive 2014/30/EU and the Low Voltage Directive 2014/35/EU.

1.3 Notes on reading this document

⚠ **WARNING**

Fatal accidents, personal injury or property damage caused by non-compliance with the documentation!

Failure to comply with the documentation may result in fatal accidents, personal injury or property damage.

- ▶ Read the documentation carefully from beginning to end
- ▶ Keep the documentation for future reference

The following table lists the various parts of the documentation in their order of reading priority.

Document type	Description
Addendum	An Addendum supplements or supersedes the relevant contents of the User’s Manual and also possibly of the Installation Instructions. If an Addendum is included in delivery, then it has the highest reading priority. All other documentation content retains its validity.
Installation Instructions	The Installation Instructions contain all the information and safety precautions needed for the proper mounting and installation of the product. The Installation Instructions have the second highest priority for reading.
Operating Instructions	The Operating Instructions contain all the information and safety precautions needed for the proper operation of the product according to its intended use. The Operating Instructions can be downloaded from www.heidenhain.com/documentation . The Operating Instructions must be read prior to commissioning the device. The Operating Instructions have the third highest priority for reading.

1.4 Validity of the documentation

Before using the documentation and the product, you need to verify that the documentation matches the product.

- ▶ Compare the ID number and the index indicated in the documentation with the corresponding data given on the ID label of the product
- > If the part numbers and indexes match, the documentation is valid.

If the ID numbers do not match so that the documentation is not valid, you will find the current documentation at **www.heidenhain.com**.

1.5 Storage and distribution of the documentation

The instructions must be kept in the immediate vicinity of the workplace and must be available to all personnel at all times. The operating company must inform the personnel where these instructions are kept. If the instructions have become illegible, the operating company must obtain a new copy from the manufacturer.

If the product is given or resold to any other party, the following documents must be passed on to the new owner:

- Addendum (if supplied)
- Installation guide
- Operating Instructions

1.6 Target group for the instructions

These instructions must be read and observed by every person who performs any of the following tasks:

- Mounting
- Installation
- Cleaning and maintenance
- Troubleshooting
- Removal
- Disposal

1.7 Notes in this documentation

Safety precautions

Precautionary statements warn of hazards in handling the device and provide information on their prevention. Precautionary statements are classified by hazard severity and divided into the following groups:

DANGER

Danger indicates hazards for persons. If you do not follow the avoidance instructions, the hazard **will result in death or severe injury**.

WARNING

Warning indicates hazards for persons. If you do not follow the avoidance instructions, the hazard **could result in death or serious injury**.

CAUTION



Caution indicates hazards for persons. If you do not follow the avoidance instructions, the hazard **could result in minor or moderate injury**.

NOTICE

Notice indicates danger to material or data. If you do not follow the avoidance instructions, the hazard **could result in property damage**.

Informational notes

Informational notes ensure reliable and efficient operation of the device. Informational notes are divided into the following groups:

-  The information symbol indicates a **tip**.
A tip provides important additional or supplementary information.
-  The gear symbol indicates a function that **depends on the machine**.
The function described depends on the machine if, for example:
 - A certain software or hardware option is required on your machine
 - The behavior of the functions depends on the configurable machine settings
-  The book symbol indicates a **cross reference**.
A cross reference leads to external documentation for example the documentation of your machine manufacturer or other supplier.

1.8 Symbols and fonts used for marking text

In these instructions the following symbols and fonts are used for marking text:

Format	Meaning
▶ ... > ...	Identifies an action and the result of this action Example: ▶ Tap OK > The message is closed
■ ... ■ ...	Identifies an item of a list Example: ■ TTL interface ■ EnDat interface ■ ...
Bold	Identifies menus, displays and buttons Example: ▶ Tap Shut down > The operating system shuts down. ▶ Turn the power switch off

2 Safety

2.1 Overview

This chapter contains important safety information needed for the proper mounting and installation of the unit.

2.2 Intended use

- The EIB 5000 series products enable monitoring of the temperature of direct drive motors. The products can evaluate up to three temperature sensors (the EIB 5181 permits evaluation of a fourth temperature sensor for the cascading of EIBs. No protective separation). The products compensate for the transmission timing behavior of the temperature measurement
- The EIB 5000 series products protect the direct drive motor from overheating. This requires that the respective control unit connected to the product evaluate the temperature or optionally available switching outputs for warnings and errors
- The devices of the EIB 5000 series serve as accessories for encoders from HEIDENHAIN and must be used only in commercial applications and in an industrial environment

2.3 Improper use

Any use not specified in 'Intended use' is considered improper use. The company operating the device is solely liable for any damage resulting from improper use.

In particular, the following uses are not permitted:

- Use with parts, cables or connections that are defective or do not comply with the applicable standards
- Use outdoors, or in potentially explosive environments or fire risk areas
- Use outside the operating conditions
- Any alterations of the device or peripherals that have not been authorized by the manufacturers
- Use as a part of a safety function
- Opening the product

2.4 Personnel qualification

The personnel for mounting, installation, operation, service, maintenance and removal must be appropriately qualified for this work and must have obtained sufficient information from the documentation supplied with the product and with the connected peripherals.

The personnel required for the individual activities to be performed on the product are indicated in the respective sections of these instructions.

The personnel groups are specified in detail as follows with regard to their qualifications and tasks.

Qualified personnel

Qualified personnel are trained by the operating company to perform advanced operation and parameterization. Due to their specialized training, knowledge, and experience, including their knowledge of the relevant regulations, qualified personnel are able to perform their assigned tasks with respect to the given application and to recognize and avoid potential hazards on their own.

Electrical specialist

Due to their technical training, knowledge, and experience, including their knowledge of the relevant standards and regulations, electrical specialists are able to work on electrical installations and to recognize and avoid potential hazards on their own. Electrical specialists have been trained specifically for the work environment in which they operate.

Electrical specialists must comply with the provisions of the applicable statutory regulations on accident prevention.

2.5 Obligations of the operating company

The operating company owns or leases the device and the peripherals. At all times, the operating company is responsible for ensuring that the intended use is complied with.

The operating company must:

- Assign the different tasks to be performed on the device to suitable, qualified and authorized personnel
- Verifiably train the personnel in the authorizations and tasks
- Provide all materials and means necessary in order for the personnel to complete the assigned tasks
- Ensure that the device is operated only when in perfect technical condition
- Ensure that the device is protected from unauthorized use

2.6 General safety precautions



The safety of any system incorporating the use of this product is the responsibility of the assembler or installer of the system.



The product supports the use of a wide variety of peripheral devices from different manufacturers. HEIDENHAIN cannot make any statements on the specific safety precautions to be taken for these devices. The safety precautions provided in the respective documentation must be observed. If there is no documentation at hand, it must be obtained from the manufacturers concerned.

The specific safety precautions required for the individual activities to be performed on the product are indicated in the respective sections of these instructions.

2.6.1 Electrical safety and voltage supply

The product must be supplied only with PELV (extra low voltage with protective separation from supply circuits; see General electrical information in the HEIDENHAIN brochure "Interfaces of HEIDENHAIN Encoders") at the control input.

The temperature sensor inputs meet the requirements for protective separation from the PELV supply voltage and the switching outputs in accordance with DIN EN 61800-5-1 and DIN EN 61010-1.

Insulation of the temperature sensors from the housing, encoder electronics, and switching outputs

Type of insulation	Reinforced insulation
System voltage	300 V
Overvoltage category	III
Pollution degree	2
Rated impulse voltage	6000 V
Elevation	EIB 52xx, EIB 5181: max. 2000 m above sea level EIB 5291S: max. 1000 m above sea level

2.6.2 Electrical safety precautions

WARNING

Hazard of contact with live parts when opening the product.

This may result in electric shock, burns, or death.

- ▶ Never operate the product with the housing open

NOTICE

Electrostatic discharge (ESD)!

This product contains electrostatic sensitive components that can be destroyed by electrostatic discharge (ESD).

- ▶ It is essential to observe the safety precautions for handling ESD-sensitive components
- ▶ Never touch connector pins without ensuring proper grounding
- ▶ Wear a grounded ESD wristband when handling the connections of the product

NOTICE

Damage to internal parts of the product!

If you open the product, the warranty and the guarantee will become void.

- ▶ Never open the housing
- ▶ Only the product manufacturer is permitted to access the inside of the product

⚠ WARNING**Hazard of dangerous amount of electricity passing through the human body upon direct or indirect contact with live electrical parts.**

This may result in electric shock, burns, or death.

- ▶ Work on the electrical system and live electrical components must be performed only by trained specialists
- ▶ For interface connections, use only cables and connectors that comply with applicable standards
- ▶ Have the manufacturer exchange defective electrical components immediately
- ▶ Regularly inspect all connected cables and all connections on the product. Defects, such as loose connections or scorched cables, must be removed immediately

3 Transport and Storage

3.1 Unpacking

- ▶ Open the top lid of the box
- ▶ Remove the packaging materials
- ▶ Unpack the contents
- ▶ Check the delivery for completeness
- ▶ Check the delivery for damage

3.2 Items supplied and accessories

3.2.1 Items supplied

The following items are included in the shipment:

- Product
- Operating Instructions
- Addendum (optional)

Further information: "Notes on reading this document", Page 7

3.2.2 Accessories

ID	Model designation
1268541-01	Mating connector for temperature sensor input for EIB 52xx (TE Connectivity version: BSTA852NN0086201A000)

Optional accessories for EIB 5181

ID	Model designation
1287073-xx	Connecting cable between EIB and TNC 1 Vpp
1286965-xx	Connecting cable between EIB and TNC EnDat

3.3 In case of damage in transit

- ▶ Have the shipping agent confirm the damage
- ▶ Keep the packaging materials for inspection
- ▶ Notify the sender of the damage
- ▶ Contact the distributor or machine manufacturer for replacement parts



If damage occurred during transit:

- ▶ Keep the packaging materials for inspection
- ▶ Contact HEIDENHAIN or the machine manufacturer

This applies also if damage occurred to requested replacement parts during transit.

3.4 Repackaging and storage

Repackage and store the device carefully in accordance with the conditions stated below.

3.4.1 Repackaging the device

Repackaging should correspond to the original packaging as closely as possible.

- ▶ Re-attach all mounted parts and dust protection caps to the device as received from the factory, or repackage them in the original packaging as received from the factory
- ▶ Repackage the device in such a way that
 - it is protected from impact and vibration during transit
 - it is protected from the ingress of dust or humidity
- ▶ Place all accessories that were included in the shipment in the original packaging
Further information: "Items supplied and accessories", Page 14
- ▶ Enclose all the documentation that was included in the original packaging
Further information: "Storage and distribution of the documentation", Page 8



If the product is returned for repair to the Service department:

- ▶ Ship the product without accessories, without encoders and without peripherals

3.4.2 Storage of the device

- ▶ Package the device as described above
- ▶ Observe the specified ambient conditions
- ▶ Inspect the device for damage after any transport or longer storage times

4 Mounting

4.1 Overview

This chapter describes the mounting of the product.

i The following steps must be performed only by qualified personnel.
Further information: "Personnel qualification", Page 10

4.2 Mounting the EIB 5000

4.2.1 EIB 5181

Variant 1

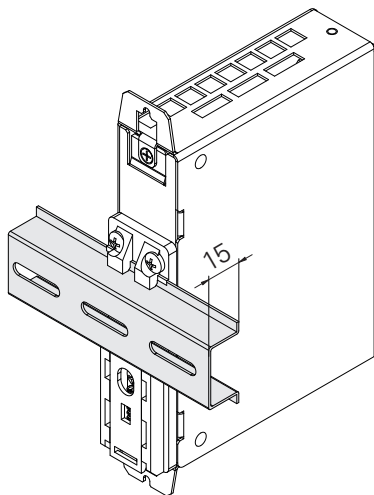

Figure 1: Mounting variant 1 with adapter

- ▶ Mount the EIB 5181 with the top hat rail adapter to a top hat rail (depth: min. 15 mm)
 Recommended: EN 50022, 35 mm x 15 mm
- ▶ Connect the protective ground to the appropriate M5 thread of the housing

i The cross section for connecting the protective conductor should be at least twice the cross section of the lines for the temperature measurement; a minimum cross section of 2.5 mm² is required, however.

Variant 2

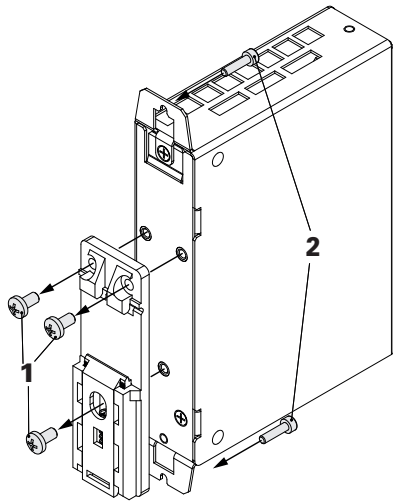

Figure 2: Mounting variant 2 without adapter

- ▶ Remove the top hat rail adapter by loosening the three screws (1)
- ▶ Use two M3 screws to fasten the EIB 5181
- ▶ Connect the protective ground to the appropriate M5 thread of the housing

i The cross section for connecting the protective conductor should be at least twice the cross section of the lines for the temperature measurement; a minimum cross section of 2.5 mm² is required, however.

4.2.2 EIB 52xx

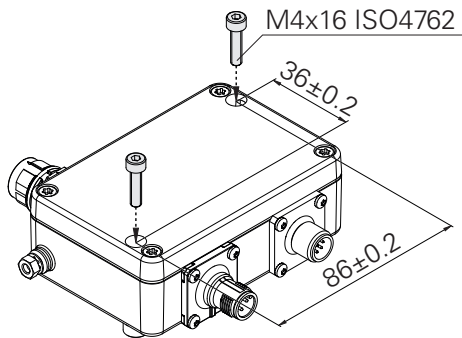

Figure 3: Mounting the EIB 52xx

- ▶ Use two M4x16 screws to fasten the EIB 52xx
- ▶ Connect the functional earth to the appropriate M5 thread of the housing.
- ▶ When mounting the cables, ensure that the connection is tight.

5 Installation



The following steps are only to be performed by electrical specialists.

Further information: "Personnel qualification", Page 10

5.1 General information

The connections on the product are protected by dust protection caps from contamination and damage.

NOTICE

Contamination or damage may result if the dust protection caps are missing!

This may impair the proper functioning of the contacts or destroy them.

- ▶ Remove dust protection caps only when connecting measuring devices or peripherals
- ▶ If you remove a measuring device or peripheral, re-attach the dust protection cap to the connection

NOTICE

Incorrect voltage supply range and incorrect wiring!

Danger of product damage and damage to the downstream electronics

- ▶ Do not engage or disengage the connecting cable between the encoder and the downstream electronics while under power

NOTICE

Electrostatic discharge (ESD)!

This product contains electrostatic sensitive components that can be destroyed by electrostatic discharge (ESD).

- ▶ It is essential to observe the safety precautions for handling ESD-sensitive components
- ▶ Never touch connector pins without ensuring proper grounding
- ▶ Wear a grounded ESD wristband when handling product connections



- Observe the minimum distances from sources of interference
- Comply with cable bend radii
- Pay attention to the different encoder connections, depending on the product version

⚠ WARNING

Danger of electric shock!

This may result in serious personal injury or death.

- ▶ Never perform any work on the product while it is under power

5.2 Product overview

- EIB 5211 (X1, X2, X3)
- EIB 5212 (X1, X2, X3, X4)
- EIB 5291S (X1, X2, X3)
- EIB 5291F (X1, X2, X3)

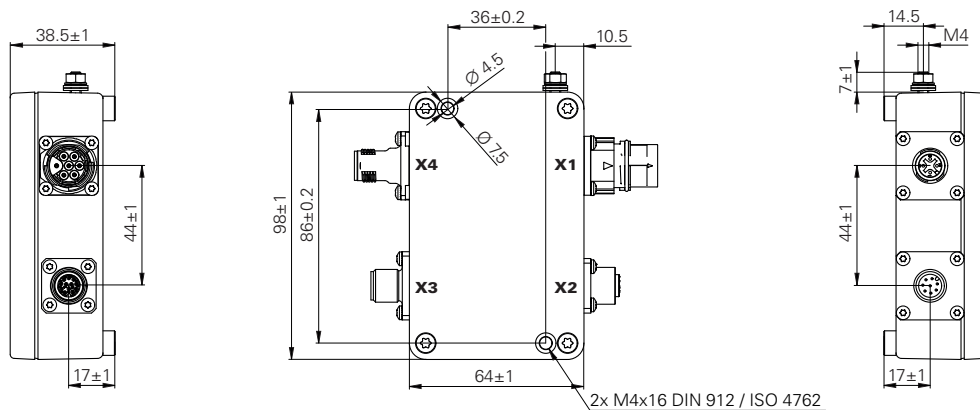

- EIB 5281 (X1, X2, X3)
- EIB 5282 (X1, X2, X3, X4)

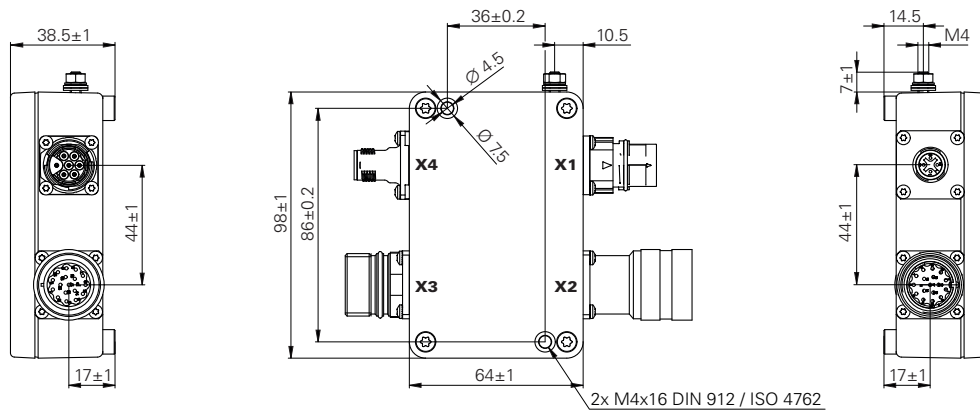

EIB 5181

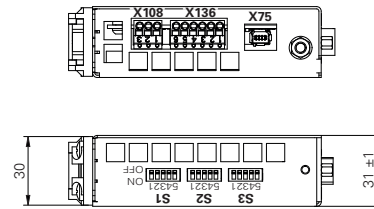
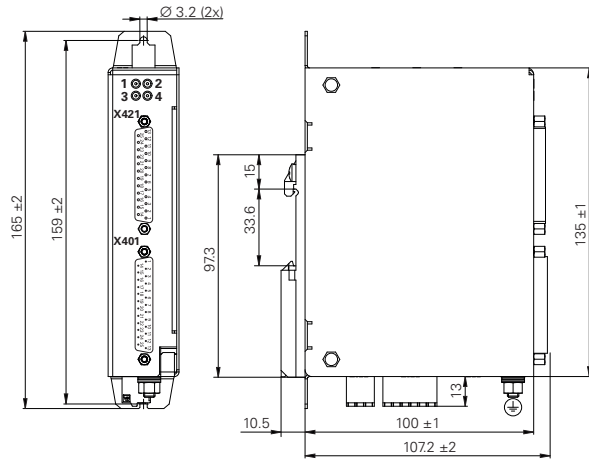
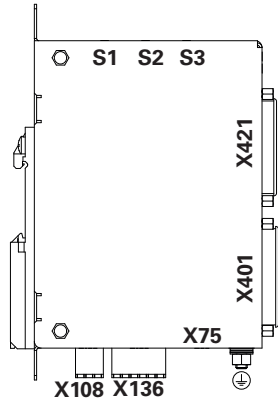

5.3 Pin layout

EIB 5181

X401					X421			
1	2	3	4	5	6	7	8	9
+5 V (U _P)	+0 V (U _N)	A+	A-	0 V	B+	B-	0 V	+12 V
10	11	12	13	14	15	16	17	18
CLOCK	+12 V	CLOCK	Temp+	Sense +5 V	DATA	Sense 0 V	R+	R-
19	20	21	22	23	24	25		
C+	C-	D+	D-	DATA	0 V	Temp-		

X136

1	2	3	4	5	6
Temp+ Sensor 1	Temp- Sensor 1	Temp+ Sensor 2	Temp- Sensor 2	Temp+ Sensor 3	Temp- Sensor 3

X108

1	2	3
Shield Temp	Shield Temp	Shield Temp

EIB 521x, EIB 5291S and EIB 5291F

X1

						
1	2	3	4	5	6	7
Temp- Sensor 1	Temp+ Sensor 1	Temp+ Sensor 2	Temp- Sensor 2	Temp+ Sensor 3	Temp- Sensor 3	⊕

X2

								
1	2	3	4	5	6	7	8	9
+V (U _P)	SIF	/	/	Sense 0 V	DATA	DATA	CLOCK	CLOCK
10	11	12						
SIF	Sense +V	0 V (U _N)						

X3 (EIB 5211, EIB 5212)

							
1	2	3	4	5	6	7	8
Sense 0 V	Sense +V	DATA	$\overline{\text{DATA}}$	0 V (U_N)	$\overline{\text{CLOCK}}$	CLOCK	+V (U_P)

X3 (EIB 5291S)

							
1	2	3	4	5	6	7	8
+V	/	RXP	RXN	0 V	TXN	TXP	/

X3 (EIB 5291F)

							
1	2	3	4	5	6	7	8
Sense 0 V	Sense +V	Serial Data	$\overline{\text{Serial Data}}$	0 V (U_N)	$\overline{\text{Request}}$	Request	+V (U_P)

X4 (EIB 5212)

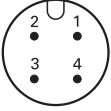
			
1	2	3	4
0 V ... 36 V	OUT 1	0 V ... 36 V	OUT 2

EIB 528x

X1

						
1	2	3	4	5	6	7
Temp- Sensor 1	Temp+ Sensor 1	Temp+ Sensor 2	Temp- Sensor 2	Temp+ Sensor 3	Temp- Sensor 3	⊥

X2

								
1	2	3	4	5	6	7	8	9
Sense +V	/	/	Sense 0 V	/	/	+V (U _P)	CLOCK	CLOCK
10	11	12	13	14	15	16	17	
0 V (U _N)	0 V	B+	B-	DATA	A+	A-	DATA	

X3

								
1	2	3	4	5	6	7	8	9
A+	A-	DATA	/	CLOCK	/	0 V (U _N)	Temp+	Temp-
10	11	12	13	14	15	16	17	
+V (U _P)	B+	B-	DATA	CLOCK	Sense 0 V	Sense +V	/	

X4 (EIB 5282)

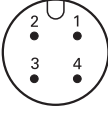
			
1	2	3	4
0 V ... 36 V	OUT 1	0 V ... 36 V	OUT 2

5.4 Connecting the temperature sensors

The EIB 52xx variants are designed to operate in a predefined manner. The connected temperature sensors and the defined time constant are indicated on the ID label and in the product brochure. The switching output for errors and warnings is preset based on the variant. All EIB 528x variants are preconfigured for using the PT1000 as temperature output format.

With the EIB 5181 variant, you can use the DIP switches to define its mode of operation. **Further information:** "DIP switch", Page 28

Example (information on ID label and assignment to X1)

- 1KTY84 1PTCD:
 - Temperature sensor 1 = KTY84-130
 - Temperature sensor 2 = PTC triplet
 - Temperature sensor 3 = Not connected
- KTY84KTY84PTCD:
 - Temperature sensor 1 = KTY84-130
 - Temperature sensor 2 = KTY84-130
 - Temperature sensor 3 = PTC triplet
- ▶ Comply with the pin layout
 - Further information:** "EIB 5181", Page 21
 - Further information:** "EIB 521x, EIB 5291S and EIB 5291F", Page 22
 - Further information:** "EIB 528x", Page 25
- ▶ Route the cable based on the mounting variant
- ▶ Connect the sensors to the respective connections. Ensure full-surface shield connection
 - EIB 5181: X136 and X108
 - EIB 52xx: X1; 7-pin M17 (male)

WARNING

Danger of electric shock!

This may result in serious personal injury or death.

If the temperature sensors are not designed to provide double or reinforced insulation:

- ▶ Connect the metal housing of the connector to protective ground

5.5 Connecting the encoder

- ▶ Comply with the pin layout
 - Further information:** "EIB 5181", Page 21
 - Further information:** "EIB 521x, EIB 5291S and EIB 5291F", Page 22
 - Further information:** "EIB 528x", Page 25
- ▶ Route the cable based on the mounting variant
- ▶ Connect the encoder to the respective connection
 - EIB 5181: X401; 25-pin D-sub (male)
 - EIB 521x, EIB 5291S and EIB 5291F: X2; 12-pin M12 (female)
 - EIB 528x: X2; 17-pin M23 (female)

5.6 Connecting the control unit

- ▶ Comply with the pin layout
 - Further information:** "EIB 5181", Page 21
 - Further information:** "EIB 521x, EIB 5291S and EIB 5291F", Page 22
 - Further information:** "EIB 528x", Page 25
- ▶ Route the cable based on the mounting variant
- ▶ Connect the control unit to the respective connection
 - EIB 5181: X421; 25-pin D-sub (female)
 - EIB 521x, EIB 5291S and EIB 5291F: X3; 8-pin M12 (male)
 - EIB 528x: X3; 17-pin M23 (male)

5.7 Connecting the switching output (optional)

- ▶ Comply with the pin layout
 - Further information:** "EIB 521x, EIB 5291S and EIB 5291F", Page 22
 - Further information:** "EIB 528x", Page 25
- ▶ Route the cable based on the mounting variant
- ▶ Connect the cable to the respective connection
 - EIB 5212: X4; 4-pin M12 (male)
 - EIB 5282: X4; 4-pin M12 (male)

Basic insulation of the supply voltage is required.

The switching outputs are protected against wire breakage (opener). The switching outputs have the following switching behavior:

Message	Temperature
Warning	Setting: 100 °C < temp. < 130 °C Resetting: temp. < 90 °C OUT2
Alarm	Setting: temp. > 130 °C Resetting: temp. < 120 °C OUT1

5.8 Connecting functional ground (EIB 52xx)

- ▶ Route the functional ground based on the mounting variant
- ▶ Connect the functional ground to the respective terminal with M5 thread

5.9 Connecting protective ground (EIB 5181)

- ▶ Route the protective ground based on the mounting variant
- ▶ Connect the protective ground to the respective terminal with M5 thread

i The cross section for connecting the protective conductor should be at least twice the cross section of the lines for the temperature measurement; a minimum cross section of 2.5 mm² is required, however.

5.10 Connecting the shield of the sensor

Route the sensor shield separately for the EIB 5181 (see X108). The metallic connecting elements ensure proper shielding for the EIB 52xx variants.

- ▶ Comply with the pin layout
- ▶ Route the cable based on the mounting variant
- ▶ Connect the cable to the respective connection
 - Connect the shield on both sides such that a low-impedance connection over a large area is ensured
 - Keep the wires short for the connection

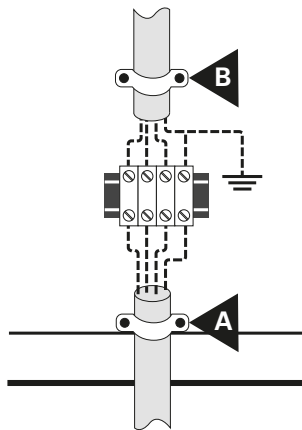

Figure 4: Recommended connection with interrupted cable shield

5.11 DIP switch

With the EIB 5181 variant, you can use the DIP switches to define its mode of operation.

Adjust the following setting parameters to the requirements of the application:

- Connected temperature sensors
- Time constant for temperature measurement
- Emulation of the temperature output

Setting the DIP switches

- ▶ Observe the following setting parameters
- ▶ Set the switches to ON or OFF

The DIP switches are located on the top of the EIB 5181. Note the arrangement of the DIP switches.

Sensor type 1

S1.3	S1.2	S1.1	Function
OFF	OFF	OFF	KTY84-130
OFF	OFF	ON	PT1000
OFF	ON	OFF	PTC
OFF	ON	ON	PTC triplet
ON	OFF	OFF	Reserved
ON	OFF	ON	Reserved
ON	ON	OFF	KTY84-130 with a common reference
ON	ON	ON	No sensor

Sensor type 2

S2.1	S1.5	S1.4	Function
OFF	OFF	OFF	KTY84-130
OFF	OFF	ON	PT1000
OFF	ON	OFF	PTC
OFF	ON	ON	PTC triplet
ON	OFF	OFF	Reserved
ON	OFF	ON	Reserved
ON	ON	OFF	KTY84-130 with a common reference
ON	ON	ON	No sensor

Sensor type 3

S2.4	S2.3	S2.2	Function
OFF	OFF	OFF	KTY84-130
OFF	OFF	ON	PT1000
OFF	ON	OFF	PTC
OFF	ON	ON	PTC triplet
ON	OFF	OFF	Reserved
ON	OFF	ON	Reserved
ON	ON	OFF	KTY84-130 with a common reference
ON	ON	ON	No sensor

Emulation of the temperature output

S2.5	Function
OFF	KTY84-130
ON	PT1000

Configuration

S3.5	Value	Function
OFF	Sensor at X401 is active	Evaluation set to PT1000 Required for cascading
ON	Sensor at X401 is inactive	Default settings

Time constant

S3.4	S3.3	S3.2	S3.1	Function
OFF	OFF	OFF	OFF	30 s
OFF	OFF	OFF	ON	28 s
OFF	OFF	ON	OFF	26 s
OFF	OFF	ON	ON	24 s
OFF	ON	OFF	OFF	22 s
OFF	ON	OFF	ON	20 s
OFF	ON	ON	OFF	18 s
OFF	ON	ON	ON	16 s
ON	OFF	OFF	OFF	14 s
ON	OFF	OFF	ON	12 s
ON	OFF	ON	OFF	10 s
ON	OFF	ON	ON	8 s
ON	ON	OFF	OFF	6 s
ON	ON	OFF	ON	4 s
ON	ON	ON	OFF	2 s
ON	ON	ON	ON	0 s

5.12 LED display of EIB 5181

The LED display shows the statuses of the sensors, errors in the configuration, or the limitation of a temperature output value.

The following statuses occur:

- The LED flashes red at power-on: the sensor is configured
- The LED is continuously red: error at the sensor input

Sensor status LED

LED	Function	Sensor connection
1	Status of sensor 1	X136 1/2
2	Status of sensor 2	X136 3/4
3	Status of sensor 3	X136 5/6
4	Status of sensor 4	X401

5.13 Cascading the EIB 5181

To incorporate more than three sensors into the calculation, you can connect multiple EIB 5181 signal converters in a row. To do so, connect the first three temperature sensors to the EIB.

- ▶ Connect the first three temperature sensors to the EIB 5181
- ▶ This EIB calculates the maximum value and stores it at the 25-pin output to the control
- ▶ Connect the 25-pin output to the control with the next EIB 5181
- ▶ Parameterize this EIB 5181 via DIP switches (S3.5)

i Parameterize the EIB 5181 via DIP switches (S3.5) such that, for the calculation of the maximum temperature, the temperature signal of the first EIB, which is passed on through the encoder connection, is considered along with the connected temperature sensors in the maximum calculation.

i For the cascading of the EIBs, use the same encoder cables as for the connection to the control.
Further information: "Optional accessories for EIB 5181", Page 14

i Please note that, for the cascading of the preceding EIBs, the temperature output must be "PT1000" (S2.5).

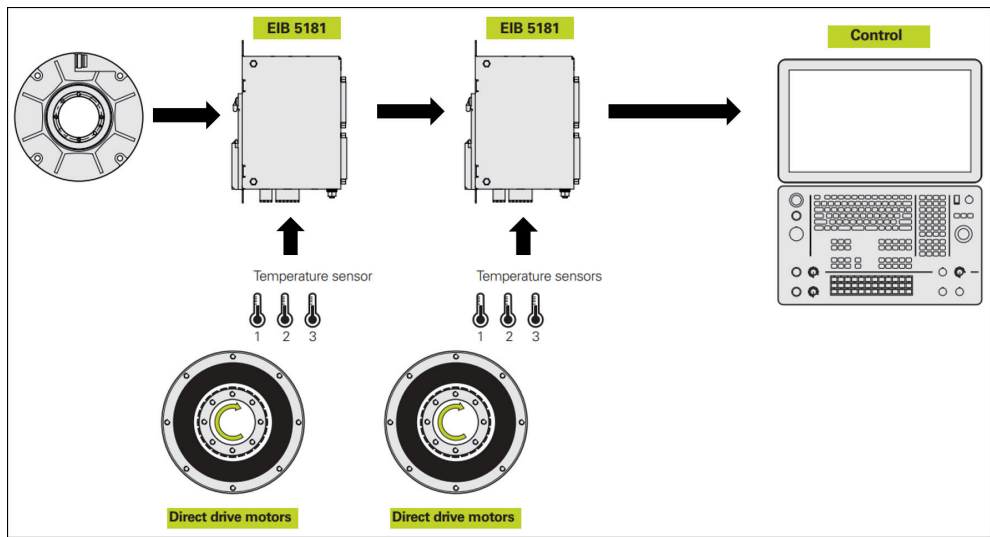

Figure 5: Cascading the EIB 51xx

i

- **EIB 521x or EIB 529x:** Cascading is not possible for the EIB 521x or EIB 529x.
- **EIB 5281:** For cascading, please contact HEIDENHAIN.

6 Servicing and Maintenance

6.1 Cleaning

NOTICE

Cleaning with sharp-edged objects or aggressive cleaning agents

Improper cleaning will cause damage to the product.

- ▶ Never use abrasive or aggressive cleaners, and never use strong detergents or solvents
 - ▶ Do not use sharp-edged objects to remove persistent contamination
-
- ▶ Use only a cloth dampened with water and a mild detergent for cleaning the exterior surfaces

6.2 Maintenance schedule

The product is largely maintenance-free.

NOTICE
<p>Operating defective devices</p> <p>Operating defective devices may result in serious consequential damage.</p> <ul style="list-style-type: none"> ▶ Do not repair or operate the device if it is damaged ▶ Replace defective devices immediately or contact a HEIDENHAIN service agency

	<p>The following steps are only to be performed by electrical specialists.</p> <p>Further information: "Personnel qualification", Page 10</p>
---	--

Maintenance step	Interval	Corrective action
▶ All labels and symbols provided on the product must be checked for readability	Annually	▶ Contact HEIDENHAIN service agency
▶ Electrical connections must be function tested and checked for damage	Annually	▶ Replace defective cables. Contact HEIDENHAIN service agency if required

7 What to do if ...

Fault conditions

The product provides a comprehensive monitoring function. Fault conditions are indicated through changes in the initial temperature value. During the initialization phase after power-on, the maximum value is output for the temperature. After this phase, the temperature value levels out at the actual measured value.

EIB 5181

- Temperature: $-15\text{ °C} \dots 200\text{ °C}$ = valid temperature values
- If the temperature value is exceeded or fallen below, the value is limited and the status LED is activated
- The status LEDs light up in case of a sensor error or invalid configuration. **Further information:** "LED display of EIB 5181", Page 30

Reaction	Fault condition	Fault	Corrective action
$\text{Temp}_{\text{max}} = 220.0\text{ °C}$	$R_{\text{Sensor}} \leq 30.0\ \Omega$	Sensor short	Check the sensor and sensor connection; exchange, if necessary
$\text{Temp}_{\text{max}} = 220.0\text{ °C}$	$R_{\text{Sensor}} \geq 6500.0\ \Omega$ ¹⁾	Sensor wire breakage	Check the sensor and sensor connection; exchange, if necessary
$\text{Temp}_{\text{max}} = 240.0\text{ °C}$	–	Invalid configuration	Contact HEIDENHAIN

¹⁾ Note: PTC/PTC triplet: no detection possible because terminating resistance is also high-impedance

EIB 521x

- Temperature: $\leq 200\text{ °C}$ = valid temperature values
- Temperature : $\geq 220\text{ °C}$ = general fault

Reaction	Fault condition	Fault	Corrective action
$\text{Temp}_{\text{max}} = -158.1\text{ °C}$	$R_{\text{Sensor}} \leq 30.0\ \Omega$	Sensor short	Check the sensor and sensor connection; exchange, if necessary
$\text{Temp}_{\text{max}} = 253.x\text{ °C}$	$R_{\text{Sensor}} \geq 6500.0\ \Omega$ ¹⁾	Sensor wire breakage x= 0: sensor 0 x= 1: sensor 1 x= 2: sensor 2	Check the sensor and sensor connection; exchange, if necessary
$\text{Temp}_{\text{max}} = 254.0\text{ °C}$	–	Invalid configuration	Contact HEIDENHAIN

¹⁾ Note: PTC/PTC triplet: no detection possible because terminating resistance is also high-impedance

EIB 528x

- Temperature: $\leq 200\text{ °C}$ = valid temperature values
- Temperature : $\geq 220\text{ °C}$ = general fault

Reaction	Fault condition	Fault	Corrective action
Temp _{max} = 220.0 °C	$R_{\text{Sensor}} \leq 30.0\ \Omega$	Sensor short	Check the sensor and sensor connection; exchange, if necessary
Temp _{max} = 220.0 °C	$R_{\text{Sensor}} \geq 6500.0\ \Omega$ ¹⁾	Sensor wire breakage	Check the sensor and sensor connection; exchange, if necessary
Temp _{max} = 240.0 °C	–	Invalid configuration	Contact HEIDENHAIN

1) Note: PTC/PTC triplet: no detection possible because terminating resistance is also high-impedance

EIB 5291F

- Temperature: $-15\text{ °C} \dots 200\text{ °C}$ = valid temperature values
- Temperature: $\geq 220\text{ °C}$ = general fault

Reaction	Fault condition	Fault	Corrective action
Temp _{max} = 223 °C	$R_{\text{Sensor}} \leq 30.0\ \Omega$	Sensor short	Check the sensor and sensor connection; exchange, if necessary
Temp _{max} = 223 °C	$R_{\text{Sensor}} \geq 6500.0\ \Omega$ ¹⁾	Sensor wire breakage	Check the sensor and sensor connection; exchange, if necessary
Temp _{max} = 223 °C	–	Invalid configuration	Contact HEIDENHAIN

1) Note: PTC/PTC triplet: no detection possible because terminating resistance is also high-impedance

EIB 5291S

- Temperature: $\leq 200\text{ °C}$ = valid temperature values
- Temperature: -300 °C = general fault

Reaction	Fault condition	Fault	Corrective action
Temp = -300 °C	$R_{\text{Sensor}} \leq 30.0\ \Omega$	Sensor short	Check the sensor and sensor connection; exchange, if necessary
Temp = -300 °C	$R_{\text{Sensor}} \geq 6500.0\ \Omega$ ¹⁾	Sensor wire breakage	Check the sensor and sensor connection; exchange, if necessary
Temp = -300 °C	–	Invalid configuration	Contact HEIDENHAIN

1) Note: PTC/PTC triplet: no detection possible because terminating resistance is also high-impedance

8 Removal and Disposal

8.1 Removal



The following steps must be performed only by qualified personnel.

Further information: "Personnel qualification", Page 10

Depending on the connected peripherals, the product may need to be removed by an electrical specialist.

In addition, the same safety precautions that apply to the mounting and installation of the respective components must be taken.

Further information: "General safety precautions", Page 11 ff.

Removing the product

To remove the product, follow the installation and mounting steps in the reverse order.

Further information: "Mounting", Page 16

Further information: "Installation", Page 18

Storage after removal

If the product is stored temporarily after removal, the information on repackaging and the specified ambient conditions must be complied with.

Further information: "Repackaging and storage", Page 15

8.2 Disposal



NOTICE

Incorrect disposal of the device!

Incorrect disposal of the device can cause environmental damage.

- ▶ Do not dispose of electrical waste and electronic components in domestic waste
- ▶ Forward the device to recycling in accordance with the applicable local disposal regulations

- ▶ If you have any questions about the disposal of the device, please contact a HEIDENHAIN service agency

HEIDENHAIN

DR. JOHANNES HEIDENHAIN GmbH

Dr.-Johannes-Heidenhain-Straße 5

83301 Traunreut, Germany

☎ +49 8669 31-0

☎ +49 8669 32-5061

info@heidenhain.de

Technical support ☎ +49 8669 32-1000

Measuring systems ☎ +49 8669 31-3104

service.ms-support@heidenhain.de

NC support ☎ +49 8669 31-3101

service.nc-support@heidenhain.de

NC programming ☎ +49 8669 31-3103

service.nc-pgm@heidenhain.de

PLC programming ☎ +49 8669 31-3102

service.plc@heidenhain.de

APP programming ☎ +49 8669 31-3106

service.app@heidenhain.de

www.heidenhain.com

