



HEIDENHAIN



**Functional
Safety**

Product Information

EIB 3392 S

Signal Converter in
Cable Design

EIB 3392 S

Signal converter in cable design with firmware version 15

- **Input:** HEIDENHAIN encoders with the EnDat22 interface
- **Output:** DRIVE-CLiQ interface

Encoder requirements

The EIB 3392 S makes it possible to connect encoders with the EnDat22 ordering designation to the DRIVE-CLiQ interface.

Depending on the firmware version of the EIB and the downstream electronics, it may be possible to connect other encoders with an EnDat22 interface. For more information, please contact HEIDENHAIN or the manufacturer of the downstream electronics.

After switch-on, the EIB checks various characteristics of the connected encoder and automatically adapts itself to it. If the encoder does not meet the necessary requirements, an error message is issued via the DRIVE-CLiQ interface.

TIME_MAX_ACTVAL

The calculation time TIME_MAX_ACTVAL specifies the earliest time (relative to the request time) after which data transfer from the encoder to the control can begin. The value depends on the parameters of the connected encoder (calculation time and resolution) and the cable length. There can also be limitations with regard to setting the cycle times. For more information, please refer to the documentation of the downstream electronics (DRIVE-CLiQ).

Online diagnostics

With EnDat 2.2 encoders, valuation numbers can be read cyclically from the encoder in order to evaluate its functionality. These valuation numbers indicate the encoder's current status and can be used to determine its "function reserves." These function reserves are also transmitted via the DRIVE-CLiQ interface and can be displayed in the higher-level control. Further information is available from HEIDENHAIN upon request.

Fastening

The EIB 3392 S must be fastened. This is possible, for example, with a 20 mm cable clamp (see also "Dimension drawing").

Power supply of encoder

The EIB 3392 S provides a voltage of $U_P = 8.0 V$ to the encoder. Please comply with the supply voltage range of the connected encoder. Due to their voltage range, certain encoders with the ordering designation EnDat22 cannot be connected (e.g., the LC 1x3, LC 4x3 and ECN 225).

	Compatible with EIB 3392 S
Absolute sealed linear encoders LC 100, LC 400, LC 200	✓
Absolute exposed linear encoders LIC 4100, LIC 3100, LIC 2100	✓
Absolute angle encoders RCN 2001, RCN 5001, RCN 8001, RCN 6000 ROC 2000, ROC 7000 ECN 2000 ECA 4000 ECM 2400 MRP 2000, MRP 5000, MRP 8000 SRP 5000	✓ ✓ ✓ ✓ ✓ ✓ ✓
Absolute singletum rotary encoders, e.g., ECN 100 ECI 100, ECI 1100, ECI 1300	✓ ✓
Absolute multitum rotary encoders, e.g., EQI 1100, EQI 1300	✓
Length gauges AT 3000 AT 1200	✓ ✓
Incremental EnDat encoders, e.g., ERM 2400, LIP 200, EIB 100, EIB 300, EIB 1500	–
Encoders with a battery buffered revolution counter, e.g., EBI 100, EBI 1100, EBI 4000	–

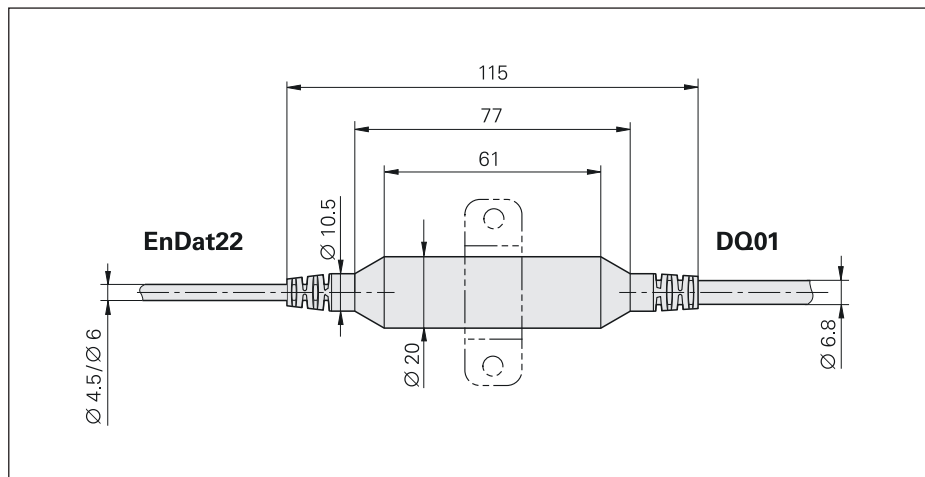

Firmware versions

The firmware version can be read out via the DRIVE-CLiQ parameter "Act_FW_Version" (index 0). The final two digits of the displayed value are decisive.

Specifications	EIB 3392 S
Functional safety	Depending on the connected encoder and downstream electronics, suitable for applications with up to: <ul style="list-style-type: none"> • SIL 2 as per EN 61508 (further basis for testing: EN 61800-5-2) • Category 3, PL d, in accordance with EN ISO 13849-1:2015
PFH	$26 \cdot 10^{-9}$ (based on an operating elevation of ≤ 1000 m above sea level)
Safe position	Determined by the connected encoder and the downstream electronics (including through the configuration); the EIB has no influence on the safe position
Input	
Interface	EnDat 2.2
Ordering designation	EnDat22 (note the <i>Encoder requirements</i>)
Electrical connection	Various connectors (see <i>Versions of the EIB 3392 S</i>)
Encoder supply voltage (U_{P2})	DC 8.0 V \pm 0.4 V, max. 1800 mW
Cable length	≤ 30 m ¹⁾
Output	
Interface	DRIVE-CLiQ
Firmware	01.32.27.15
SINAMICS, SIMOTION ²⁾	\geq V4.6HF3
SINUMERIK with safety ²⁾	\geq V4.7 SP1 HF1
SINUMERIK without safety ²⁾	\geq V4.5 SP2 HF4
Calculation time TIME_MAX_ACTVAL	Refer to <i>TIME_MAX_ACTVAL</i> on page 2
Ordering designation	DQ01
Electrical connection	Various connectors (see <i>Versions of the EIB 3392 S</i>)
Cable length	≤ 30 m ³⁾
Supply voltage (U_{P1})	DC 24 V (16.0 V to 28.8 V) (up to DC 36.0 V possible without impairing functional safety)
Power consumption	<i>Maximum</i> At 16.0 V: ≤ 3200 mW At 28.8 V: ≤ 3300 mW <i>Typical</i> At 24 V: 1000 mW + $1.15 \times P_{Mtyp}$ (with P_{Mtyp} = Typical power consumption of the encoder)
Elevation	≤ 1000 m
Operating temperature	0 °C to 60 °C
Storage temperature	-30 °C to 70 °C
Vibration 55 Hz to 2000 Hz Shock 11 ms	100 m/s ² (IEC 60068-2-6) 200 m/s ² (IEC 60068-2-27)
Protection rating EN 60529	IP65 ⁴⁾
Mass	≈ 0.2 kg (with 1 m cable length on both sides)

¹⁾ With HEIDENHAIN cable. Comply with the supply voltage at the encoder

²⁾ Information from Siemens as per the document "Certified encoders with DRIVE-CLiQ Dependencies on SIMOTION / SINUMERIK and SINAMICS Hardware and Software versions" (version: 04/2019)

³⁾ Depending on the output cable; the plug connection to the EIB is to be considered a DRIVE-CLiQ coupling.

⁴⁾ Use the correct connector version

Versions of the EIB 3392S

Overview of connection options (the encoders are examples)

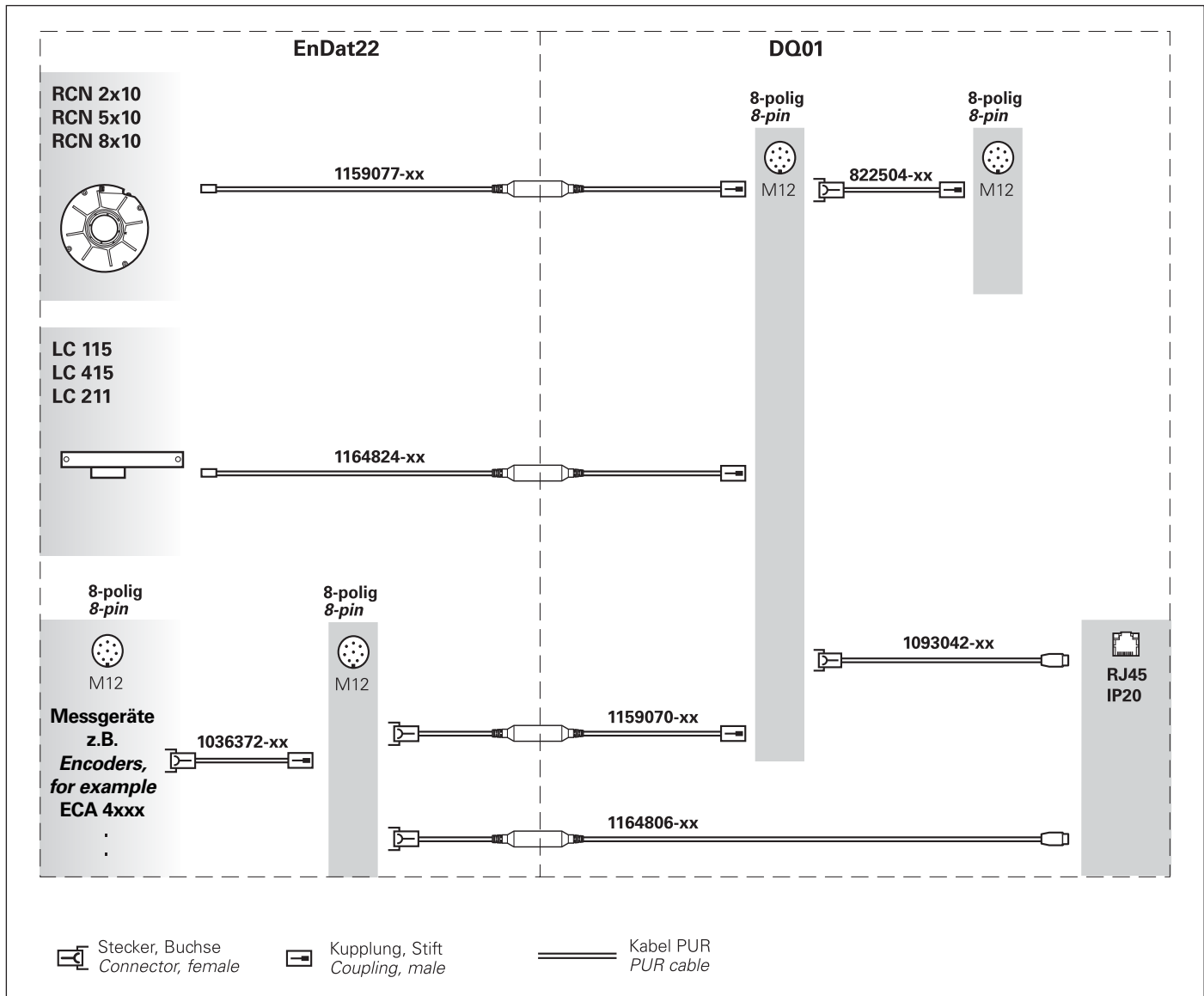

Overview of ID numbers for the EIB 3392S

ID	Input			Output		
	Connecting elements	Cable Ø/A _P	Cable length	Connecting elements	Cable Ø/A _P	Cable length
1159077-11	12-pin ultra-lock connector (female)	4.5 mm/ 2 · 0.16 mm ²	2.5 m	8-pin M12 connector (male)	6.8 mm/ 1 · 0.24 mm ²	0.5 m
1164824-11	14-pin M12 connector (female)	4.5 mm/ 2 · 0.16 mm ²	2.5 m	8-pin M12 connector (male)	6.8 mm/ 1 · 0.24 mm ²	0.5 m
1159070-11	8-pin M12 connector (female)	6 mm/ 2 · 0.16 mm ²	1 m	8-pin M12 connector (male)	6.8 mm/ 1 · 0.24 mm ²	1 m
1164806-11	8-pin M12 connector (female)	6 mm/ 2 · 0.16 mm ²	0.5 m	6-pin RJ45 connector, IP20 (male)	6.8 mm/ 1 · 0.24 mm ²	2.5 m

A_P: Cross-section of wires for the power supply voltage
Other versions are available upon request.

Temperature sensor information

The EIB 3392S does not have a temperature sensor input, but it can evaluate the temperature sensor information from connected EnDat encoders and pass it on via the DRIVE-CLiQ interface. Information from up to four temperature sensors can be transmitted. The EIB 3392S supports transmission from:

- One internal temperature sensor (the value is provided in the DRIVE-CLiQ parameter "Encoder Temperature")
- Up to three external temperature sensors (the values are provided in the DRIVE-CLiQ parameter "Motor temperature 2-4"; the calculated highest value of the three sensors is output in the parameter "Motor temperature 1")

The EIB 3392S can simultaneously process the information of one external and one internal temperature sensor. If more than one external temperature sensor is used, then the value of the internal temperature sensor can no longer be provided.

The evaluation of the connected sensors can be set via the DRIVE-CLiQ interface, depending on the settings of the EnDat encoder. This enables evaluation of KTY 84-130, PT 1000 and PTC temperature sensors. For more information, please contact HEIDENHAIN.

For more information about the availability and mapping of the temperature sensor information, please refer to the documentation of the connected EnDat encoder.

Designation of the connecting cables

The connecting cables for input and output have differing colors.

The interfaces and their ordering designations "EnDat22" and "DQ01" are printed on the ID label. Arrows indicate the proper connection.

Functional safety

The EIB can be used in safety-related applications, but only if functional safety is supported by the connected encoder. The characteristics pertaining to functional safety are largely determined by the connected encoder and the downstream electronics (if required, contact the manufacturer; the EIB passes on the main characteristics of the encoder).

The **safe position** is also largely determined by the connected encoder and the downstream electronics. The EIB itself does not influence the safe position. The "safe position" and "safety-related measuring step (SM)" of the connected EnDat encoder are required in order for the safe position to be calculated. For more information, please contact the manufacturer of the downstream electronics.

The **PFH value** of the overall system (EIB 3392S + encoder) is the sum of the PFH values of the EIB 3392S and the connected encoder. For information about the encoder, please refer to its documentation (Product Information document, brochure, and mounting instructions).

The EIB 3392S is designed for a **service life** of 20 years (in accordance with ISO 13849). For more information about using the EIB and the encoder in safety-related applications, please contact the manufacturer of the downstream electronics.

Limitations

For linear encoders with measuring lengths greater than 50 m, there may be limitations to the output of the commutation angle via the DRIVE-CLiQ interface under certain circumstances. Please contact HEIDENHAIN in such cases. HEIDENHAIN recommends setting the datum shift in the downstream electronics. If the datum shift is used in the EnDat area, then it must be less than 3 m and not result in position values less than zero.



Please note:

In order for the EIB 3392S to be operated in safety-related applications, the software must be designed in conformity with the downstream DRIVE-CLiQ electronics. For more information on availability, please contact the manufacturer.





EnDat22:
Black cable

DQ01:
Green cable





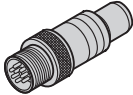

Interfaces

Pin layout of the EIB input

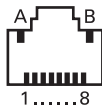
Mating connector 8-pin M12 coupling   								
	Power supply				Serial data transmission			
	8	2	5	1	3	4	7	6
EnDat	U _{P2}	Sensor U _{P2}	0V	Sensor 0V	DATA	DATA	CLOCK	CLOCK

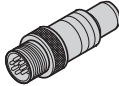
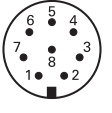
Siemens pin layout

RJ45 connector  			8-pin M12 coupling   			
	Power supply		Serial data transfer			
	A	B	3	6	1	2
	1	5	7	6	3	4
	U _P	0V	TXP	TXN	RXP	RXN

Cable shield connected to housing; **U_P** = Power supply voltage

DRIVE-CLiQ is a registered trademark of Siemens AG

HEIDENHAIN

DR. JOHANNES HEIDENHAIN GmbH

Dr.-Johannes-Heidenhain-Straße 5

83301 Traunreut, Germany

☎ +49 8669 31-0

FAX +49 8669 32-5061

info@heidenhain.de

www.heidenhain.com

This Product Information document supersedes all previous editions, which thereby become invalid. The basis for ordering from HEIDENHAIN is always the Product Information document edition valid when the order is placed.



More information:

To ensure proper and intended use, comply with the specifications in the following documents:

- Brochure: *Interfaces of HEIDENHAIN Encoders* 1078628-xx
- Brochure: *Cables and Connectors* 1206103-xx
- Operating Instructions: *EIB 3392S* 1380708-xx
- Brochure, Product Information, and Mounting Instructions of the connected encoder