



HEIDENHAIN



Product Information

ECN 2000

Absolute Angle Encoders
with Integral Bearing

ECN 2000

- Mounted stator coupling
- Hollow through shaft: $\varnothing 50$ mm
- System accuracy: $\pm 10''$

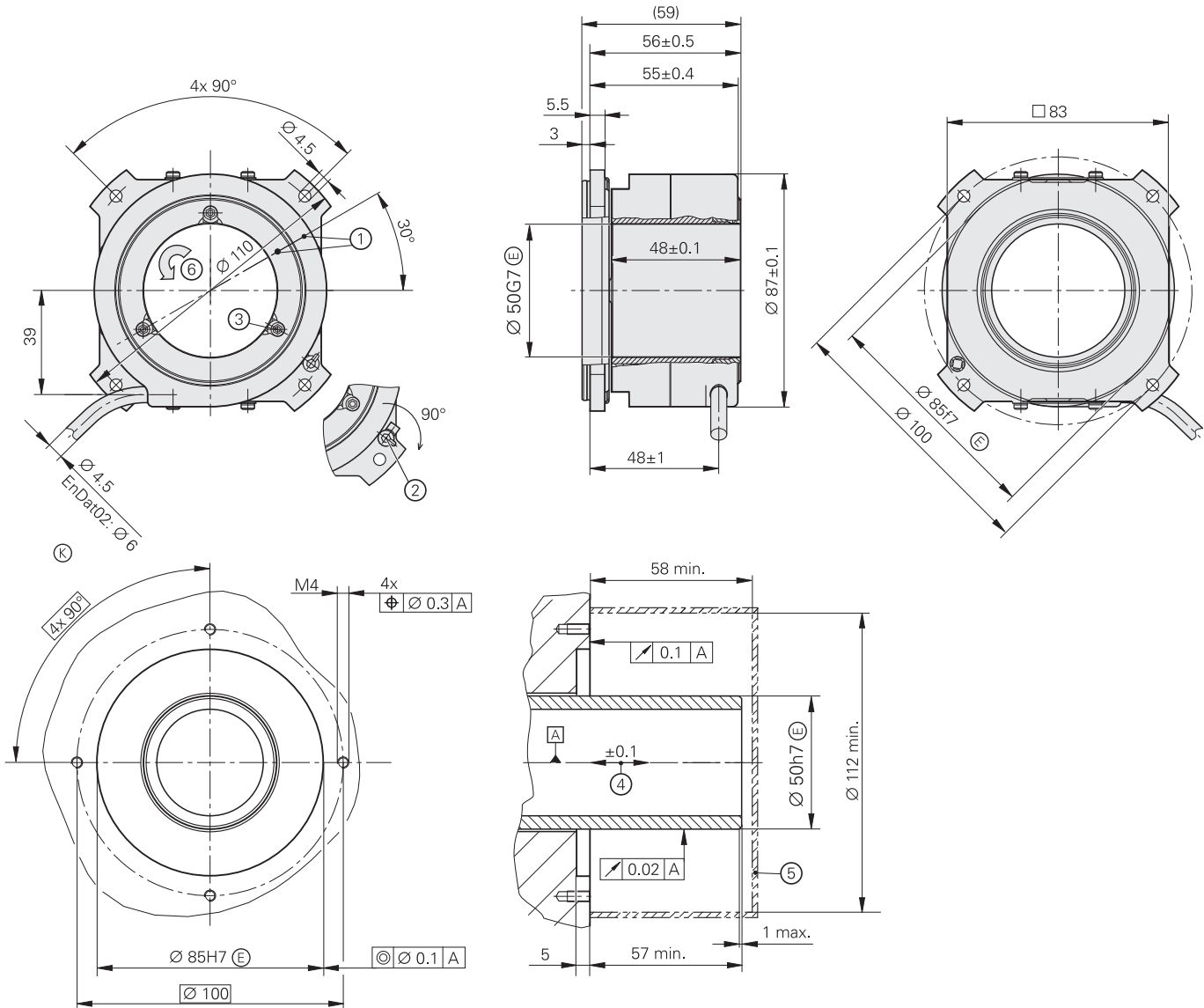

mm

 Tolerancing ISO 8015
 ISO 2768 - m H
 ≤ 6 mm: ± 0.2 mm

- \square = Bearing of mating shaft
- \oplus = Required mating dimensions
- 1 = Marking of the 0° position $\pm 15^\circ$
- 2 = Release the mounting aid by turning prior to initial operation; width A/F 3
- 3 = Width A/F 3 ($3 \times 120^\circ$); tightening torque: 2.5 Nm + 0.5 Nm
- 4 = Stated tolerance contains the mounting tolerances and thermal expansion; no dynamic movement permitted
- 5 = Comply with protection against contact (EN 60529)
- 6 = Direction of shaft rotation for the output signals in accordance with the interface description

	ECN 2110	ECN 2180	ECN 2190F	ECN 2190M
Measuring standard	DIADUR circular scale with absolute and incremental track (2048 lines)			
System accuracy	±10"			
Position error per signal period	≤ ±1.5"			
Interface	EnDat 2.2		Fanuc Serial Interface αi Interface	Mitsubishi High Speed Interface
Ordering designation*	EnDat22	EnDat02	Fanuc05	Mit03-4
Position values per rev.	33554432 (25 bits); with Fanuc α Interface 8388608 (23 bits)			
Electrically permissible speed	≤ 3000 rpm for continuous position value			
Clock frequency	≤ 16 MHz	≤ 2 MHz	–	
Calculation time t_{cal}	≤ 6 μs	≤ 9 μs	–	
Incremental signals	–	~ 1 V _{PP}	–	
Cutoff frequency –3 dB	–	≥ 400 kHz	–	
Electrical connection*	Cable (1 m) with 8-pin M12 coupling (male)	Cable (1 m) with 17-pin M23 coupling (male)	Cable (1 m) with or without an 8-pin M12 coupling (male)	
Cable length ¹⁾	≤ 150 m		≤ 50 m	≤ 30 m
Supply voltage	DC 3.6V to 14V			
Power consumption ²⁾ (maximum)	3.6 V: ≤ 0.7 W 14 V: ≤ 0.8 W			
Current consumption (typical)	5 V: 100 mA (without load)			
Shaft	Hollow through shaft, 50 mm			
Mech. permissible speed	≤ 3000 rpm			
Starting torque (at 20 °C)	≤ 0.2 Nm			
Moment of inertia of rotor	220 · 10 ⁻⁶ kgm ²			
Permiss. axial motion of measured shaft	±0.1 mm			
Natural frequency	≥ 1000 Hz			
Vibration 55 Hz to 2000 Hz Shock 6 ms	≤ 100 m/s ² (EN 60068-2-6) ≤ 200 m/s ² (EN 60068-2-27)			
Operating temperature	<i>Moving cable:</i> –10 °C to 60 °C <i>Stationary cable:</i> –20 °C to 60 °C			
Protection EN 60529	IP64			
Mass	≈ 0.7 kg			

* Please select when ordering

¹⁾ With HEIDENHAIN cable

²⁾ See *General electrical information* in the *Interfaces of HEIDENHAIN Encoders* brochure

Mounting

The **ECN 2000** angle encoders have an integral bearing, a hollow shaft and a stator-side coupling. The measured shaft is directly connected to the shaft of the angle encoder.

The circular scale is firmly connected to the hollow shaft. The scanning unit rides on the shaft on ball bearings and is connected to the housing with a stator-side coupling. The stator coupling and the sealing design greatly compensate for axial and radial mounting errors without restricting functionality or accuracy. This therefore simplifies mounting. During angular

acceleration of the shaft, the coupling must absorb only the torque resulting from friction within the bearing. Angle encoders with a stator coupling therefore exhibit excellent dynamic performance.

Mounting

The housing of the ECN 2000 is firmly connected to the mounting surface of the machine component via a mounting flange and a centering collar. For coupling to the shaft, the ECN with its hollow shaft is press-fitted onto the motor shaft and clamped on the rotor side with three eccentric clamps.

Materials to be used for mounting the ECN 2000

The machine shaft and the fastening components must be made of steel. The material must exhibit a coefficient of thermal expansion of $\alpha = (10 \text{ to } 16) \cdot 10^{-6} \text{ K}^{-1}$.

Additionally, the material must meet the following specifications:

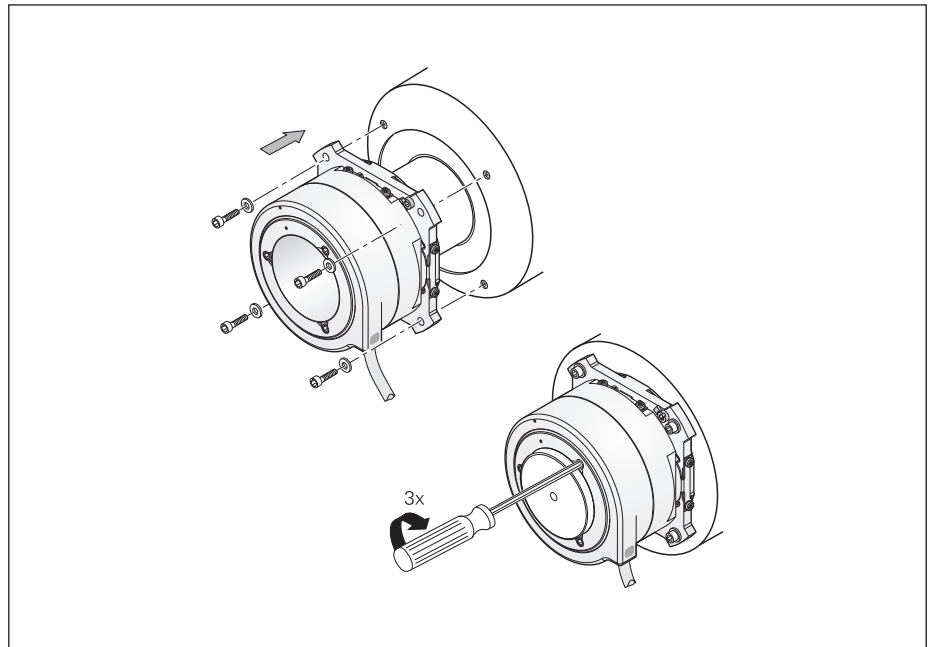

- For a hollow shaft connection
 $R_m \geq 650 \text{ N/mm}^2$
 $R_{p0.2} \geq 370 \text{ N/mm}^2$
- For a housing connection
 $R_{p0.2} \geq 370 \text{ N/mm}^2$





Mounting an ECN 2000 with a $\varnothing 50 \text{ mm}$ hollow shaft

Electrical connection

EnDat connecting cable without incremental signals

PUR adapter cables and connecting cable \varnothing 6 mm; $2(2 \times 0.09 \text{ mm}^2) + 2(2 \times 0.16 \text{ mm}^2)$		$A_P = 2 \times 0.16 \text{ mm}^2$
Adapter cable with 8-pin M12 connector (female) and 15-pin D-sub connector (female)		1036521-xx
Adapter cable with 15-pin connector (female) and 15-pin D-sub connector (male)		1036526-xx
Connecting cable with 8-pin M12 connector (female) and 8-pin M12 coupling (male)		1036372-xx

EnDat adapter cable with incremental signals

PUR adapter cables and connecting cable \varnothing 8 mm; $4(2 \times 0.16 \text{ mm}^2) + 4 \times 0.5 \text{ mm}^2 + 4 \times 0.16 \text{ mm}^2$		$A_P = 0.5 \text{ mm}^2$
Adapter cable with 17-pin M23 connector (female) and 15-pin D-sub connector (female)		332115-xx
Adapter cable with 17-pin M23 connector (female) and 15-pin D-sub connector (male)		324544-xx
Connecting cable with 17-pin M23 connector (female)		309778-xx

Fanuc/Mitsubishi connecting cable

PUR connecting cable \varnothing 6 mm; $2(2 \times 0.09 \text{ mm}^2) + 2(2 \times 0.16 \text{ mm}^2)$		$A_P = 2 \times 0.16 \text{ mm}^2$	Fanuc	Mitsubishi
Fully assembled with 8-pin M12 connector (female) and 8-pin M12 coupling (male)			1036372-xx	

A_P : Cross section of power supply lines

\varnothing : Cable diameter (for bend radii, see the *Interfaces of HEIDENHAIN Encoders* brochure)

For more cables, see the brochure *Angle Encoders with Integral Bearing*.

HEIDENHAIN

DR. JOHANNES HEIDENHAIN GmbH

Dr.-Johannes-Heidenhain-Straße 5

83301 Traunreut, Germany

☎ +49 8669 31-0

FAX +49 8669 32-5061

info@heidenhain.de

www.heidenhain.com

This Product Information document supersedes all previous editions, which thereby become invalid. The basis for ordering from HEIDENHAIN is always the Product Information document edition valid when the order is placed.



More information:

Comply with the requirements described in the following documents to ensure correct and intended operation:

- Brochure: *Angle Encoders with Integral Bearing* 591109-xx
- Brochure: *Interfaces of HEIDENHAIN Encoders* 1078628-xx
- Brochure: *Cables and Connectors* 1206103-xx

For brochures and Product Information documents, visit www.heidenhain.com.