



HEIDENHAIN



**Functional
Safety**

Product Information

ECN 1123
EQN 1135

Absolute Rotary Encoders
with 1KA Positive-Locking
Hollow Shaft for Safety-
Related Applications

01/2023

ECN 1123, EQN 1135

Rotary encoders for absolute position values with safe singleturn information

- 75A mounted stator coupling
- 1KA blind hollow shaft (Ø 6 mm) for axial clamping

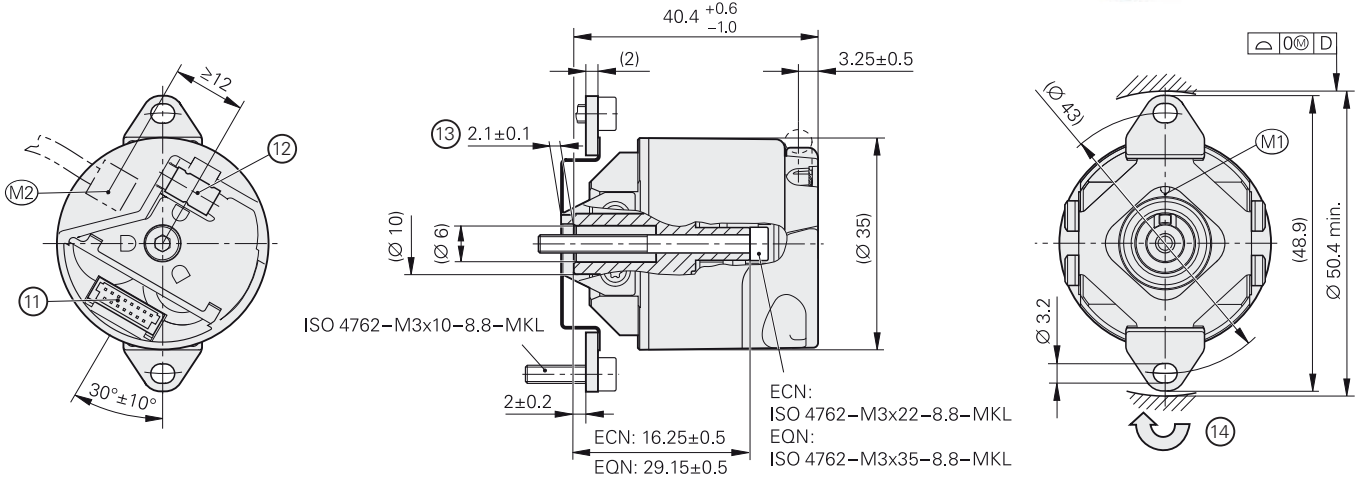

Required mating dimensions

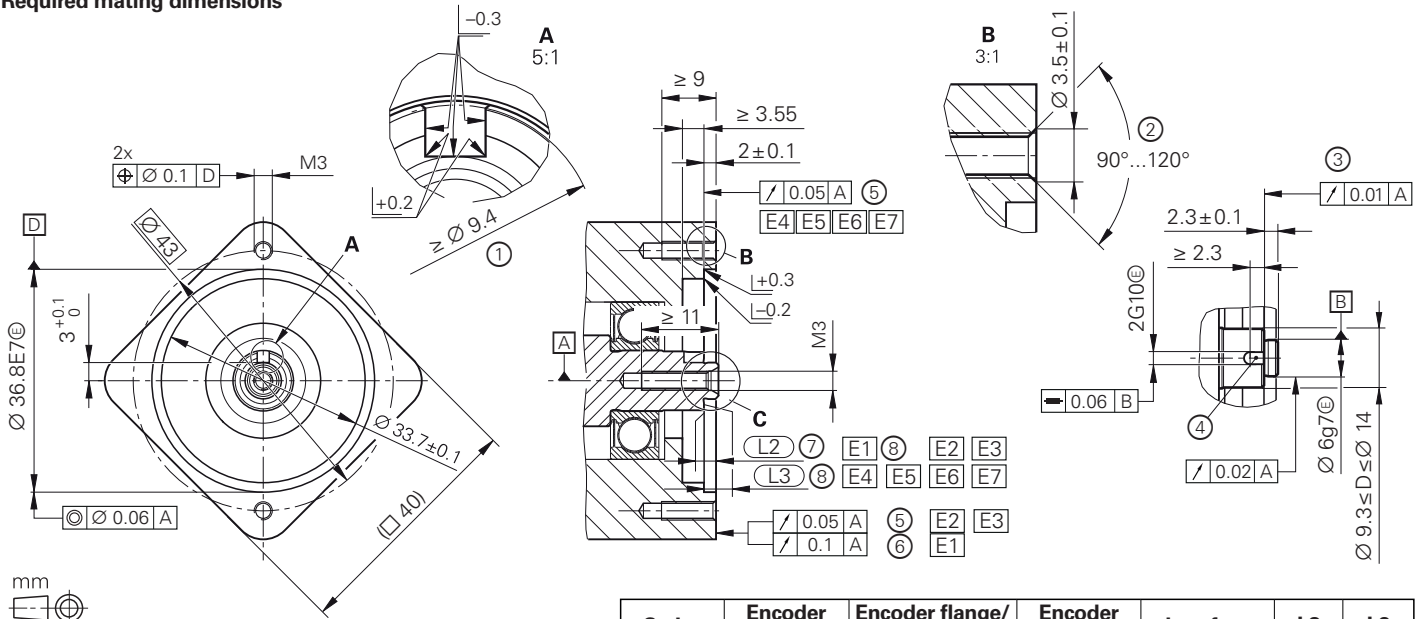

mm
 Tolerancing ISO 8015
 ISO 2768:1989-mH
 ≤ 6 mm: ±0.2 mm

- ☐ = Bearing of mating shaft
- M1 = Measuring point for operating temperature
- M2 = Measuring point for vibration
- 1 = Contact surface of slot
- 2 = Chamfer at start of thread is mandatory for material bonding anti-rotation lock
- 3 = Shaft surface; ensure full-surface contact!
- 4 = Slot required only for ECN/EQN and ECI/EQI with WELLA1 = 1KA
- 5 = ExI flange surface; ensure full-surface contact!
- 6 = Coupling surface of ECN/EQN
- 7 = Maximum permissible deviation between the shaft surface and coupling surface; compensation of mounting tolerances and thermal expansion, of which ±0.15 mm of dynamic axial motion is permitted
- 8 = Maximum permissible deviation between shaft and flange surfaces; compensation of mounting tolerances and thermal expansion
- 9 = Undercut
- 10 = Possible centering hole
- 11 = 15-pin PCB connector
- 12 = Fastening for cable with crimp sleeve (diameter: 4.3 mm ±0.1 mm; 7 mm long)
- 13 = Positive locking element; ensure correct engagement in Slot 4 (e.g., by measuring the device overhang)
- 14 = Direction of shaft rotation for ascending position values
- 15 = Uncoated; shaft coating not permitted

Series	Encoder name	Encoder flange/ stator coupling	Encoder shaft	Interface	L2	L3
E1	ECN/EQN	75A	1KA	EnDat01/22 DQ01	2±0.5	-
E2/E3	ECI/EQI	70C	1KA/82A	EnDat22/ E30-R2	2±0.4	-
E4/E6	ECI/EQI	70F	82A	EnDat22/ E30-R2	-	0±0.4
E5	ECI/EQI	70F	82A	EnDat01	-	0±0.3
E7	ECI/EQI	70E	82C	EnDat22	-	0±0.3

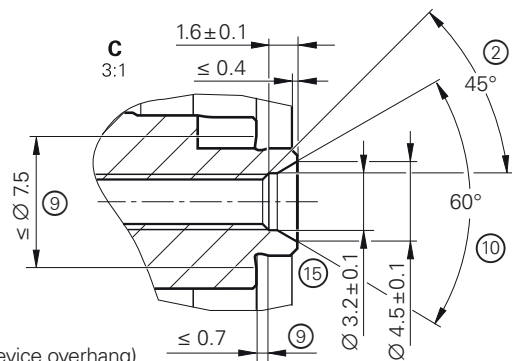

Specifications	ECN 1123 singleturn	EQN 1135 multiturn
Functional safety for applications with up to	As a single-encoder system for monitoring functions <ul style="list-style-type: none"> • SIL 1, as per EN 61508 (further basis for testing: IEC 61800-5-3) • Category 2, PL c as per EN ISO 13849-1:2015 As single-encoder system for closed-loop functions <ul style="list-style-type: none"> • SIL 2, as per EN 61508 (further basis for testing: IEC 61800-5-3) • Category 3, PL d, in accordance with EN ISO 13849-1:2015 Safe in singleturn operation	
PFH	$\leq 15 \cdot 10^{-9}$ (probability of dangerous failure per hour)	
Safe position ¹⁾	<i>Encoder</i> : $\pm 1.76^\circ$ (safety-related measuring step: SM = 0.7°) <i>Mechanical coupling</i> : $\pm 2^\circ$ (exclusion for loosening of shaft and stator coupling; designed for accelerations of $\leq 300 \text{ m/s}^2$)	
Interface/ordering designation	EnDat 2.2/EnDat22	
Position values per revolution	8388608 (23 bits)	
Revolutions	–	4096 (12 bits)
Calculation time t_{cal} /clock frequency	$\leq 7 \mu\text{s}/\leq 8 \text{ MHz}$	
System accuracy at 20 °C	$\pm 60''$	
Supply voltage	DC 3.6 V to 14 V	
Power consumption ²⁾ (maximum)	At 3.6 V: $\leq 600 \text{ mW}$; at 14 V: $\leq 700 \text{ mW}$	At 3.6 V: $\leq 700 \text{ mW}$; at 14 V: $\leq 800 \text{ mW}$
Current consumption (typical)	At 5 V: 85 mA (without load)	At 5 V: 105 mA (without load)
Electrical connection	15-pin PCB connector (with connection for external temperature sensor ³⁾)	
Cable length	$\leq 100 \text{ m}$ (see EnDat description in the <i>Interfaces of HEIDENHAIN Encoders</i> brochure)	
Shaft	1KA blind hollow shaft ($\varnothing 6 \text{ mm}$) with positive-locking element	
Shaft speed	$\leq 12000 \text{ rpm}$	
Starting torque (typical)	$\leq 0.001 \text{ Nm}$ (at 20 °C)	$\leq 0.002 \text{ Nm}$ (at 20 °C)
Moment of inertia of rotor	$0.4 \cdot 10^{-6} \text{ kgm}^2$	
Angular acceleration of rotor	$\leq 0.8 \cdot 10^5 \text{ rad/s}^2$	
Natural frequency f_N (typical)	$\geq 1000 \text{ Hz}$	
Axial motion of measured shaft	$\leq \pm 0.5 \text{ mm}$	
Vibration 55 Hz to 2000 Hz Shock 6 ms	$\leq 200 \text{ m/s}^2$ (EN 60068-2-6); 10 Hz to 55 Hz constant over 3.2 mm peak to peak $\leq 2000 \text{ m/s}^2$ (EN 60068-2-27)	
Operating temperature	–40 °C to 110 °C	
Trigger threshold for temperature exceedance ⁴⁾	125 °C (measuring accuracy of the internal temperature sensor: $\pm 5 \text{ K}$)	
Relative humidity	$\leq 93 \%$ (40 °C/21 d as per EN 60068-2-78); without condensation	
Protection EN 60529	IP40 (read about insulation under <i>Electrical safety</i> in the <i>Interfaces of HEIDENHAIN Encoders</i> brochure; contamination from the ingress of fluids must be avoided)	
Mass	$\approx 0.1 \text{ kg}$	
ID number	743586-01 743586-51 (collective packaging)	743587-01 743587-51 (collective packaging)

¹⁾ Further tolerances may arise in the downstream electronics after position value comparison (contact mfr.)

²⁾ See *General electrical information* in the *Interfaces of HEIDENHAIN Encoders* brochure

³⁾ Evaluation optimized for KTY 84-130 (see *Temperature measurement in motors* in the *Encoder for Servo Drives* brochure)

⁴⁾ The internal temperature evaluation is not designed for functional safety

Mounting

The blind hollow shaft of the rotary encoder is seated onto the measured shaft and fastened with a central screw. It is particularly important to ensure that the positive-locking element of the rotary encoder shaft securely engages the corresponding slot in the measured shaft. Mounting on the stator side is performed without a centering collar on a flat surface with two clamping screws. Use screws with material bonding anti-rotation lock (see *Mounting accessories*).

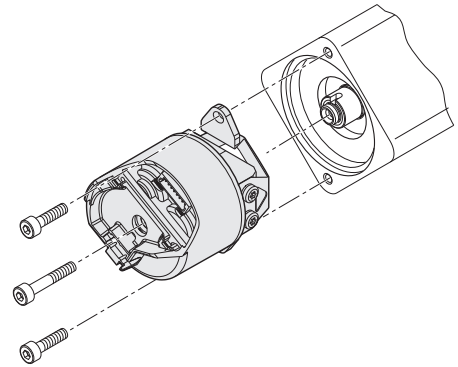

Mounting accessories

Screws

Screws (central screw, mounting screws) are not included in delivery and can be ordered separately.

	Screws ¹⁾		Lot size
Central screw for ECN 1123	ISO 4762-M3x22-8.8-MKL	ID 202264-65	10 or 100
Central screw for EQN 1135	ISO 4762-M3x35-8.8-MKL	ID 202264-66	
Fastening screw for flange	ISO 4762-M3x10-8.8-MKL	ID 202264-87	20 or 200

¹⁾ With coating for material bonding anti-rotation lock

Please note the information on screws from HEIDENHAIN in the *Encoders for Servo Drives* brochure, under the heading *Screws with material bonding anti-rotation lock* in the chapter *General mechanical information*.

Mounting aid

To avoid damage to the cable, use the mounting aid to connect and disconnect the cable assembly. The pulling force must be applied solely to the connector and not to the wires.

ID 1075573-01

Mounting aid

The mounting aid allows the shaft of the rotary encoder to be turned from the rear of the device, making it easy to find the positive-locking connection between the encoder shaft and the measured shaft.

ID 821017-03



More information:

For the customer-side mounting design, the material properties and conditions in accordance with the General mechanical information in the *Encoders for Servo Drives* brochure (ID 208922-xx) must be complied with.



The material specifications for aluminum and steel apply both to the customer-side shaft and stator.

ID 1075573-01
HEIDENHAIN



Electrical connection

Cables



Output cables inside the motor housing		
With 15-pin PCB connector and 8-pin M12 flange socket (male); TPE wires in braided sleeve and wires for a temperature sensor		TPE $10 \times 0.16 \text{ mm}^2$ ^{1) 2)} ID 1117412-xx
With 15-pin PCB connector; $\varnothing 3.7 \text{ mm}$ EPG (with shield crimping $\varnothing 4.5 \text{ mm}$) and wires for temperature sensor		EPG $1 \times (4 \times 0.06 \text{ mm}^2) + 4 \times 0.06 \text{ mm}^2$ ²⁾ + TPE $2 \times 0.16 \text{ mm}^2$ ID 1108078-xx

¹⁾ Wires with braided sleeve

²⁾ The shield connection must be implemented on the motor

Information for safety-related applications: Document the bit error rate in accordance with Specification 533095!

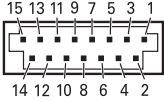
Pin layout

15-pin PCB connector										
										
	Power supply				Serial data transmission				Other signals ¹⁾	
	13	11	14	12	7	8	9	10	5	6
	U_P	Sensor U_P	0V	Sensor 0V	DATA	DATA	CLOCK	CLOCK	T⁺ ²⁾	T⁻ ²⁾
	Brown/ Green	Blue	White/ Green	White	Gray	Pink	Violet	Yellow	Brown	Green

¹⁾ Only with output cables inside the motor housing

²⁾ Connections for external temperature sensor; evaluation optimized for KTY 84-130
(see *Temperature measurement in motors* in the *Encoders for Servo Drives* brochure)

Cable shield connected to housing; **U_P** = Power supply voltage

Sensor: The sense line is connected in the encoder with the corresponding power line.

Vacant pins or wires must not be used!

Note for safety-related applications: Only completely assembled HEIDENHAIN cables are qualified.

Do not modify cables or exchange their connectors without first consulting with HEIDENHAIN Traunreut!

Output cables with a cable length > 0.5 m require strain relief for the cable.

HEIDENHAIN

DR. JOHANNES HEIDENHAIN GmbH

Dr.-Johannes-Heidenhain-Straße 5

83301 Traunreut, Germany

☎ +49 8669 31-0

FAX +49 8669 32-5061

info@heidenhain.de

www.heidenhain.com

This Product Information document supersedes all previous editions, which thereby become invalid. The basis for ordering from HEIDENHAIN is always the Product Information document edition valid when the order is placed.



More information:

Comply with the requirements described in the following documents to ensure correct and intended operation:

- Operating Instructions

1390321-xx