



HEIDENHAIN



Product Information

ECI 4090S

Absolute Rotary Encoder
with 180 mm Hollow Shaft
and DRIVE-CLiQ Interface for
Safety-Related Applications

Firmware 15



04/2024

ECI 4090 S

Rotary encoder for absolute position values with safe singleturn information

- Robust inductive scanning principle
- Hollow through shaft (Ø 180 mm)
- Consists of a scanning unit and scale drum

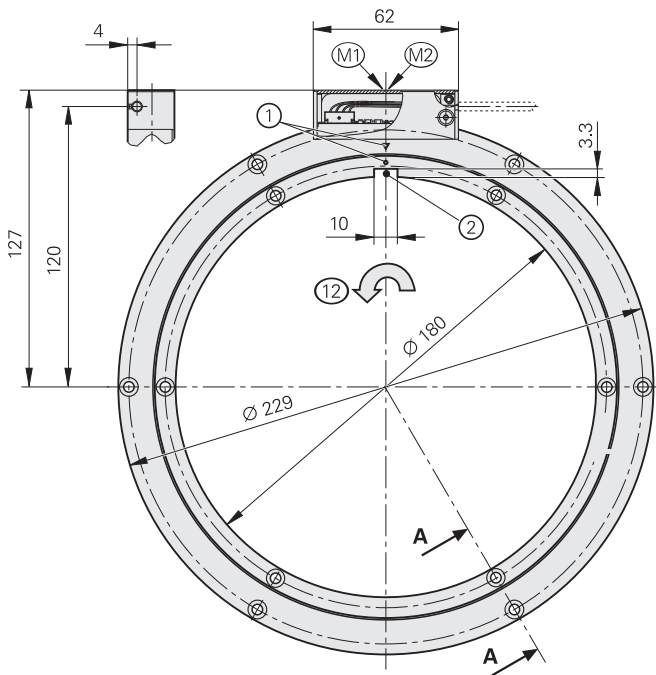

Shown with customer's side

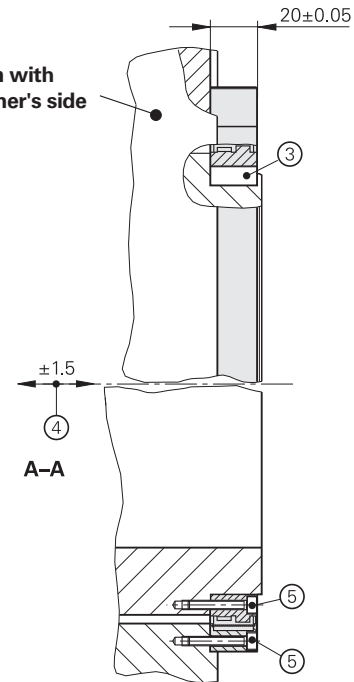

Required mating dimensions

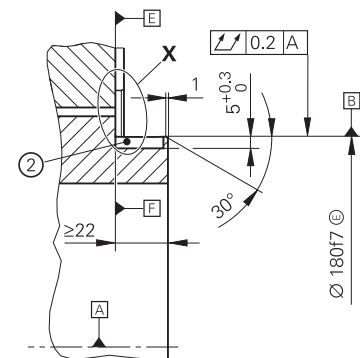
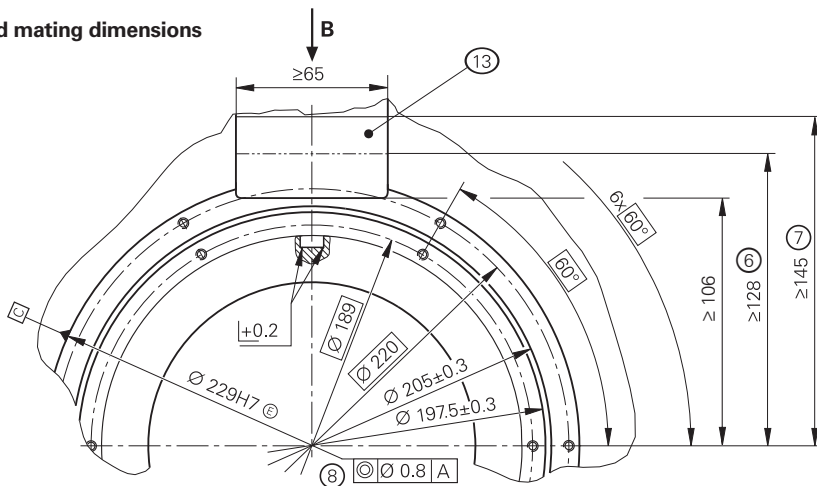

mm
 Tolerancing ISO 8015
 ISO 2768:1989-mH
 ≤ 6 mm: ±0.2 mm

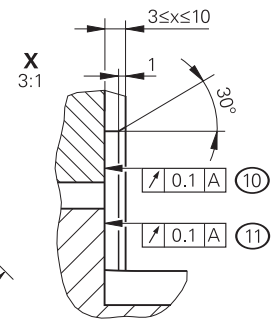
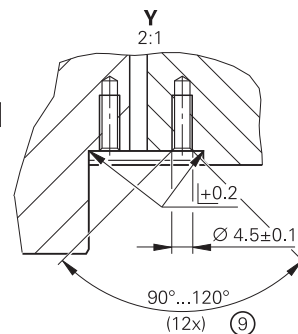
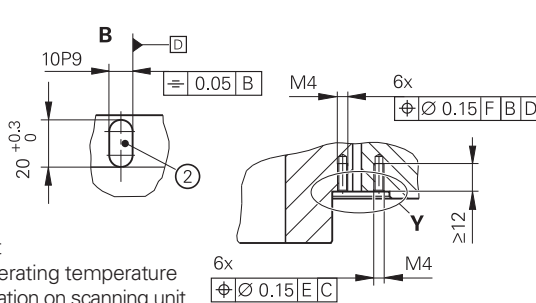

ⓐ = Bearing of mating shaft

M1 = Measuring point for operating temperature

M2 = Measuring point for vibration on scanning unit

1 = Marking of the 0° position ±5°

2 = Slot for machine key: DIN 6885 – A – 10 x 8 x 20

3 = Machine key: DIN 6885 – A – 10 x 8 x 20

4 = Maximum permissible axial deviation between the shaft surface and flange surface;

compensation of mounting tolerances and thermal expansion; dynamic motion permitted over entire range

5 = Fastening screws: ISO 4762 – M4 x 25 – 8.8; tightening torque: 2.2 Nm ±0.13 Nm; a suitable material bonding anti-rotation lock must be used for the screw connection (e.g., screw with material bonding anti-rotation lock: ISO 4762 – M4 x 25 – 8.8 MKL as per DIN 267-27, ID 202264-88).

6 = Space required when encoder cover is closed

7 = Space required for opening the encoder cover

8 = Coaxiality of stator mating surface

9 = Chamfer at start of thread is mandatory for material bonding anti-rotation lock

10 = Bearing surface of stator

11 = Bearing surface of rotor

12 = Direction of shaft rotation for ascending position values

13 = The mating surface does not need to be fully covered by the scanning unit in this area

Specifications	ECI 4090 S singleturm
Functional safety for applications with up to	As a single-encoder system for monitoring functions and closed-loop functions <ul style="list-style-type: none"> • SIL 2 as per EN 61508 (further basis for testing: IEC 61800-5-3) • Category 3, PL d as per EN ISO 13849-1:2015 Safe in the singleturm range
PFH ¹⁾	$SIL\ 2: \leq 27 \cdot 10^{-9}$ (probability of dangerous failure per hour)
Safe position ²⁾	<i>Encoder</i> : $\pm 0.44^\circ$ (safety-related measuring step: $SM = 0.176^\circ$) <i>Mechanical coupling</i> : $\pm 0.5^\circ$ (fault exclusion for the loosening of AE scanning unit and TTR scale drum, designed for acceleration of $AE: \leq 400\ m/s^2$; of $TTR: \leq 600\ m/s^2$)
Interface	DRIVE-CLiQ
Ordering designation	DQ01
Firmware	01.32.27.15
<i>SINAMICS, SIMOTION³⁾</i>	$\geq V4.6\ HF3$
<i>SINUMERIK with safety³⁾</i>	$\geq V4.7\ SP1\ HF1$
<i>SINUMERIK without safety³⁾</i>	$\geq V4.5\ SP2\ HF4$
Position values per revolution	1 048 576 (20 bits)
Calculation time TIME_MAX_ACTVAL ⁴⁾	$\leq 11\ \mu s$
System accuracy	$\pm 40''$
Electrical connection	15-pin PCB connector (with connection for external temperature sensor ⁵⁾)
Cable length ⁶⁾	$\leq 40\ m$ (see description in the <i>Interfaces of HEIDENHAIN Encoders</i> brochure)
Supply voltage	DC 24 V (10 V to 28.8 V); up to 36 V possible without limiting functional safety
Power consumption ⁷⁾ (max.)	At 10 V: $\leq 1100\ mW$; at 28.8 V: $\leq 1250\ mW$
Current consumption (typical)	At 24 V: 40 mA (without load)
Shaft	Hollow through shaft $\varnothing 180\ mm$ (with keyway)
Shaft speed	$\leq 6000\ rpm$
Moment of inertia of rotor	$3.1 \cdot 10^{-3}\ kgm^2$ (without screws, without key)
Angular acceleration of rotor	$\leq 2 \cdot 10^4\ rad/s^2$
Axial motion of measured shaft	$\leq \pm 1.5\ mm$

¹⁾ For use at an elevation of $\leq 1000\ m$ above sea level

²⁾ Further tolerances may arise in the downstream electronics after position value comparison (contact mfr. of the downstream electronics)

³⁾ Information from Siemens as per the document "Certified encoders with DRIVE-CLiQ Dependencies on SIMOTION / SINUMERIK and SINAMICS Hardware and Software versions" (version: 04/2019)

⁴⁾ The calculation time TIME_MAX_ACTVAL specifies the time after which a data transfer from the encoder to the control can start within the current-regulator clock time

⁵⁾ See *Temperature measurement in motors* in the *Encoders for Servo Drives* brochure

⁶⁾ With an output cable length (inside the motor) $\leq 1\ m$

⁷⁾ See *General electrical information* in the *Interfaces of HEIDENHAIN Encoders* brochure

DRIVE-CLiQ is a registered trademark of Siemens AG.

Specifications	ECI 4090 S singletum	
Vibration 55 Hz to 2000 Hz ⁸⁾ Shock 6 ms	<i>AE scanning unit:</i> ≤ 400 m/s ² ; <i>TTR scale drum:</i> ≤ 600 m/s ² (EN 60068-2-6) ≤ 2000 m/s ² (EN 60068-2-27)	
Operating temperature	−40 °C to 100 °C (at the measuring point and on the entire scale drum)	
Trigger threshold for exceeded temperature error message	120 °C (measuring accuracy of the internal temperature sensor: ±1 K)	
Relative humidity	≤ 93 % (40 °C/21 d as per EN 60068-2-78); condensation excluded	
Protection rating EN 60529	<i>Complete encoder, mounted:</i> IP20 ⁹⁾ ; <i>AE scanning unit:</i> IP40 (read about insulation under <i>Electrical safety</i> in the <i>Interfaces of HEIDENHAIN Encoders</i> brochure)	
Mass	<i>AE scanning unit:</i> ≈ 0.39 kg; <i>TTR scale drum:</i> ≈ 0.33 kg	
ID number	<i>AE ECI4090S scanning unit:</i> ID 1087527-04	<i>TTR EXI4000 scale drum:</i> ID 1113606-02

⁸⁾ *AE scanning unit:* 10 Hz to 55 Hz, 6.5 mm constant peak to peak; *TTR:* 10 Hz to 55 Hz, 10 mm constant peak to peak

⁹⁾ In the application, the encoder must be protected from abrasive and harmful media; use an appropriate enclosure as needed

Mounting

The scale drum of the rotary encoder is pressed onto the measured shaft's centering collar and fastened. The stator is mounted via an external centering diameter. Use screws with material bonding anti-rotation lock (see *Mounting accessories*).

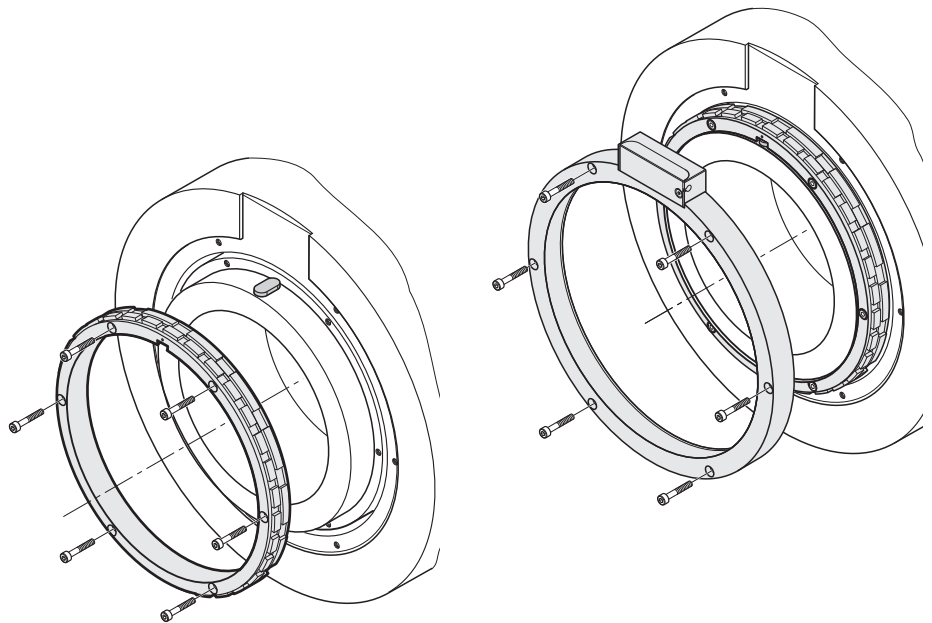

For the fault exclusion design for functional safety, the following material properties and conditions for the mating surfaces are assumed. Four possible material combinations are permitted for the customer-side stator and rotor.

	Material			
	Aluminum	Hardenable wrought aluminum alloy	Steel	Unalloyed heat-treated steel
Tensile strength R_m	$\geq 220 \text{ N/mm}^2$		$\geq 600 \text{ N/mm}^2$	
Yield strength $R_{p0.2}$ or yield point R_e	-		$\geq 400 \text{ N/mm}^2$	
Shear strength τ_a	$\geq 130 \text{ N/mm}^2$		$\geq 390 \text{ N/mm}^2$	
Interface pressure P_G	$\geq 250 \text{ N/mm}^2$		$\geq 660 \text{ N/mm}^2$	
Modulus of elasticity E (at 20 °C)	70 kN/mm ² to 75 kN/mm ²		200 kN/mm ² to 215 kN/mm ²	
Coefficient of thermal expansion α_{therm} (at 20 °C)	$\leq 25 \cdot 10^{-6} \text{ K}^{-1}$		$10 \cdot 10^{-6} \text{ K}^{-1}$ to $17 \cdot 10^{-6} \text{ K}^{-1}$	
Surface roughness R_z	$\leq 16 \text{ }\mu\text{m}$			
Friction values	Mounting surfaces must be clean and free of grease. Use screws from HEIDENHAIN in their delivery condition.			
Tightening procedure	Use a signal-emitting torque wrench as per DIN EN ISO 6789, with an accuracy of $\pm 6\%$			
Mounting temperature	15 °C to 35 °C			

Protection from contact (EN 60529)

After encoder installation, all rotating parts must be protected from accidental contact during operation.

Mounting accessories

Screws

Screws are not included in delivery and can be ordered separately.

ECI 4090 S	Screws ¹⁾		Lot size
Mounting screws for stator and rotor	ISO 4762-M4x25-8.8-MKL	ID 202264-88	60 or 300

¹⁾ With coating for material bonding anti-rotation lock

Please note the information on screws from HEIDENHAIN in the *Encoders for Servo Drives* brochure, under the heading *Screws with material bonding anti-rotation lock* in the chapter *General mechanical information*.

Key

The machine key is not included in delivery.

Mounting aid

To avoid damage to the cable, use the mounting aid to connect and disconnect the cable assembly. The pulling force must be applied solely to the connector and not to the wires.

ID 1075573-01

For further mounting information and mounting aids, please refer to the *Encoders for Servo Drives* brochure.

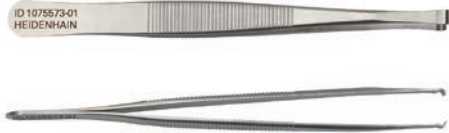

Electrical requirements

Switch-on and switch-off conditions

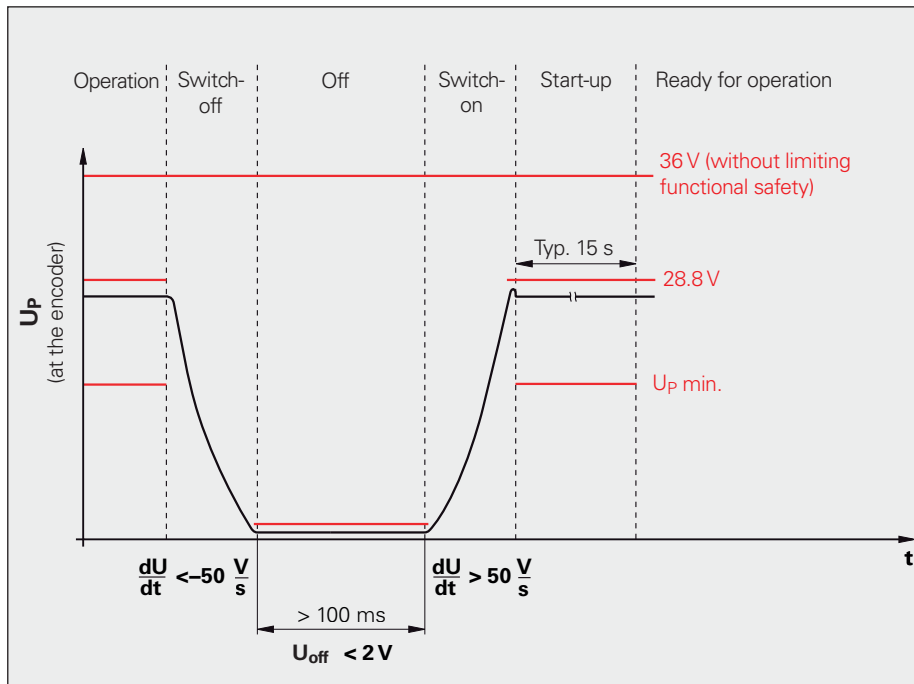

Integrated temperature evaluation

These rotary encoders feature an internal temperature sensor integrated into the encoder electronics, as well as an evaluation circuit for an external temperature sensor. In both cases, the respective digitized temperature value is transmitted purely serially via the DRIVE-CLiQ interface. Please bear in mind that neither the temperature measurement nor the transmission of the temperature value is "safe" in terms of functional safety.

The temperature measured by the internal temperature sensor is higher by a device-specific and application-specific amount than the temperature at measuring point M1, as shown in the dimension drawing.

Upon reaching a trigger threshold for the internal temperature sensor, these rotary encoders issue an "Alarm 135" error message. This threshold may vary depending on the device and is stated in the specifications.

During operation, it is recommended that the temperature be kept adequately below this threshold. Fulfillment of the encoder's intended use requires adherence to the operating temperature at measuring point M1.

Temperature measurement in motors

To protect a motor from overloading, the motor manufacturer usually installs a temperature sensor in close proximity to the motor winding. A PT 1000 temperature sensor or a KTY 84-130 semiconductor sensor, for example, is to be used for this purpose.

For a PT1000, the following values apply with regard to the accuracy of the evaluation circuit:

$\pm 6 \text{ K}$ at $-40 \text{ }^\circ\text{C}$ to $80 \text{ }^\circ\text{C}$
 $\pm 4 \text{ K}$ at $80.1 \text{ }^\circ\text{C}$ to $160 \text{ }^\circ\text{C}$
 $\pm 6 \text{ K}$ at $160.1 \text{ }^\circ\text{C}$ to $200 \text{ }^\circ\text{C}$

For a KTY 84-130 semiconductor sensor, the following values apply with regard to the accuracy of the evaluation circuit:

$\pm 6 \text{ K}$ at $-40 \text{ }^\circ\text{C}$ to $80 \text{ }^\circ\text{C}$
 $\pm 3 \text{ K}$ at $80.1 \text{ }^\circ\text{C}$ to $160 \text{ }^\circ\text{C}$
 $\pm 6 \text{ K}$ at $160.1 \text{ }^\circ\text{C}$ to $200 \text{ }^\circ\text{C}$

The temperature values are transmitted via the DRIVE-CLiQ protocol. The temperature sensor used is adjustable via Parameter 601 in the configuration software (e.g., Starter software) of the drive.







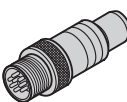

Online diagnostics and firmware version

For evaluation of the encoder's functionality, valuation numbers can be cyclically read from the encoder. These valuation numbers reflect the current status of the encoder and can be used to determine its function reserves. The function reserves are also transmitted via the DRIVE-CLiQ interface and can be displayed in the higher-level control. Further information is available from HEIDENHAIN upon request.

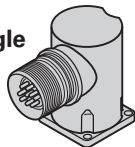
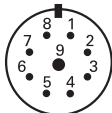
The firmware version can be read via the DRIVE-CLiQ parameter "Act_FW_Version" (index 0). The final two digits of the displayed value are decisive.

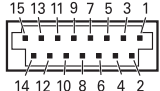
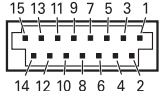
Electrical connection: pin layout

Pin layout of the ECI

8-pin M12 coupling		9-pin M23 right-angle socket				15-pin PCB connector				
										
	Power supply				Serial data transmission				Other signals ¹⁾	
 M12	8	2	5	1	3	4	7	6	/	/
 M23	3	7	4	8	5	6	1	2	/	/
 15	13	11	14	12	7	8	9	10	5	6
	–	–	0V	U_p	RXP	RXN	TXP	TXN	T⁺ ²⁾	T⁻ ²⁾
	Brown/ Green	Blue	White/ Green	White	Gray	Pink	Violet	Yellow	Brown	Green

¹⁾ Only with output cables inside the motor housing

²⁾ Connections for an external temperature sensor (depending on the output cable inside the motor housing; see *Temperature measurement in motors* in the *Encoders for Servo Drives* brochure)



Cable shield connected to housing; **U_p** = Power supply voltage

Note about safety-related applications: use only sufficiently qualified, completely assembled DRIVE-CLiQ cables from HEIDENHAIN or Siemens. Do not modify or assemble cables without first consulting with HEIDENHAIN Traunreut!

Vacant pins or wires must not be used!

Electrical connection





Cables

EPG output cables inside the motor housing \varnothing 3.7 mm; $2(2 \times 0.06) + (4 \times 0.06) \text{ mm}^2$; $A_P = 0.06 \text{ mm}^2$ with shield crimping \varnothing 4.3 mm		
With 15-pin PCB connector and 9-pin M23 SpeedTEC angle flange socket (male); wires for temperature sensor ¹⁾		ID 1125403-N3 ²⁾ ; length: 0.3 m
With 15-pin PCB connector and 9-pin M23 SpeedTEC angle flange socket (male)		ID 1125408-N3 ²⁾ ; length: 0.3 m
With 15-pin PCB connector and 8-pin M12 coupling (male)		ID 1160559-01 ³⁾ ; length: 1 m

¹⁾ The electromagnetic compatibility of the complete system must be ensured

²⁾ Operating temperature range (conditional): $-20 \text{ }^\circ\text{C}$ to $120 \text{ }^\circ\text{C}$

³⁾ Operating temperature range (conditional): $-40 \text{ }^\circ\text{C}$ to $85 \text{ }^\circ\text{C}$

PUR connecting cables \varnothing 6.8 mm; $2(2 \times 0.17 \text{ mm}^2) + (2 \times 0.24 \text{ mm}^2)$; $A_P = 0.24 \text{ mm}^2$		
With 8-pin M12 connector (female) and 8-pin M12 coupling (male)		ID 822504-xx
With 8-pin M12 connector (female) and RJ45 connector (IP67)		ID 1094652-xx
With 8-pin M12 connector (female) and RJ45 connector (IP20)		ID 1093042-xx
With 9-pin M23 SpeedTEC connector (female) and RJ45 connector (IP20)		ID 1121546-xx
With 9-pin M23 SpeedTEC connector (female) and 8-pin M12 coupling (male)		ID 1121536-xx

A_P : Cross section of power supply lines

Output cables may require strain relief. Always provide strain relief for cable lengths $> 0.5 \text{ m}$.

SpeedTEC is a registered trademark of Intercontec Pfeiffer Industriesteckverbindungen GmbH.
DRIVE-CLiQ is a registered trademark of Siemens AG.

HEIDENHAIN

DR. JOHANNES HEIDENHAIN GmbH

Dr.-Johannes-Heidenhain-Straße 5

83301 Traunreut, Germany

☎ +49 8669 31-0

FAX +49 8669 32-5061

info@heidenhain.de

www.heidenhain.com

This Product Information document supersedes all previous editions, which thereby become invalid. The basis for ordering from HEIDENHAIN is always the Product Information document edition valid when the order is placed.



More information:

Comply with the requirements described in the following documents to ensure correct and intended operation:

- Brochure: *Encoders for Servo Drives* ID 208922-xx
- Brochure: *Cables and Connectors* ID 1206103-xx
- Mounting instructions: *AE ECI4090S* ID 1214406-xx
- Mounting instructions: *TTR EXI4000* ID 1214404-xx
- Brochure: *Interfaces of HEIDENHAIN Encoders* ID 1078628-xx