



HEIDENHAIN



Adjusting and Testing Software (ATS)

User's Manual

Adjusting and Testing Software
for Use with PWM
Software ID 539862-xx
Version 4.2.0

English (en)
11/2025

Table of contents

1	Fundamentals.....	13
1.1	Overview.....	14
1.2	Information on the product.....	14
1.3	Software options.....	14
1.4	Validity of the documentation.....	14
1.5	Hardware compatibility.....	15
1.6	Notes on reading this document.....	16
1.7	Storage and distribution of the documentation.....	17
1.8	Target groups.....	17
1.9	Symbols and fonts used for marking text.....	18
1.10	Figures.....	18
1.11	More information.....	18
2	Safety.....	19
2.1	Overview.....	20
2.2	Notes in this documentation.....	20
2.3	Safety precautions in the Adjusting and Testing Software.....	21
2.4	Intended use.....	21
2.5	Improper use.....	21
2.6	Personnel qualification.....	21
2.7	Obligations of the operating company.....	22
2.8	General safety precautions.....	22

3	Inspecting encoders with the encoder diagnostic set.....	23
3.1	Overview.....	24
3.2	Measuring methods and interfaces.....	24
3.3	Operating modes of the testing device.....	26
3.3.1	Encoder diagnostics.....	27
3.3.2	Monitoring mode.....	29
3.3.3	Signal adapter for EnDat 3 interface type.....	31
3.3.4	Bus operation.....	32
3.4	Overview of functions.....	33
3.5	Transfer of values and signals.....	35
3.6	Units and tolerances.....	36
4	Installing the software.....	37
4.1	Overview.....	38
4.2	System requirements.....	38
4.3	Installing the software.....	38
4.4	Checking the installation.....	39
4.5	PWM 20, PWM 21: Installing drivers.....	40
4.6	PWM 3000 network settings.....	40
4.7	Updating software and encoder database.....	40
4.8	Uninstalling the software.....	41

5	Basic operation.....	43
5.1	Overview.....	44
5.2	Structure of the user interface.....	44
5.3	Recurring displays and operating elements.....	45
5.4	Starting the software.....	46
5.5	Exiting the software.....	47
5.6	Viewing software information.....	47
5.7	Opening documentation.....	47
5.8	Adjusting, exporting and printing diagrams.....	48
5.8.1	Magnifying the diagram view.....	48
5.8.2	Moving an image section.....	48
5.8.3	Reducing the diagram view.....	48
5.8.4	Exporting diagrams.....	49
5.8.5	Printing the diagram.....	50
6	Configuring the software.....	51
6.1	Overview.....	52
6.2	Switching the language.....	52
6.3	Enabling software options.....	53
6.4	Deactivating software options.....	54
6.5	Updating the documentation.....	55
6.6	Selecting the PWM as testing device.....	55
6.7	Saving log information.....	57

7	Connecting the encoder.....	59
7.1	Overview.....	60
7.2	Connection in the Encoder Diagnostics operating mode.....	63
7.2.1	Connection with encoder ID.....	64
7.2.2	Manual connection.....	65
7.2.3	Connecting in bus operation.....	66
7.3	Connecting in Monitoring mode.....	72
7.3.1	Connection with encoder ID.....	73
7.3.2	Manual connection.....	76
7.4	Disconnecting the encoder.....	79
7.5	Connecting touch probes.....	80
7.6	Disconnecting the touch probe.....	84
8	Encoder mounting (mounting wizard).....	85
8.1	Encoder mounting with mounting wizard.....	86

9	Inspecting encoders with sinusoidal incremental signals.....	91
9.1	Overview.....	92
9.2	Checking incremental signals.....	93
9.2.1	Incremental signal function.....	93
9.2.2	Analog view.....	94
9.2.3	Examining the incremental signals A and B (Analog view).....	103
9.2.4	Checking the reference signal (Analog view).....	109
9.2.5	Checking commutation signals C and D (Analog view).....	112
9.2.6	Counter view.....	115
9.2.7	Checking the counting function (Counter view).....	119
9.2.8	PWT view.....	126
9.2.9	Running a rapid test with the PWT test function (PWT view).....	129
9.2.10	Homing – Limit view.....	130
9.2.11	Checking Limit switching signals (Homing – Limit view).....	132
9.2.12	Protocol view.....	134
9.2.13	Saving log data (Protocol view).....	135
9.2.14	Note view.....	136
9.2.15	Displaying and deleting notes (Note view).....	136
9.3	Recording and analyzing incremental signals.....	137
9.3.1	Recording function.....	137
9.3.2	Recording view.....	137
9.3.3	Recording and analyzing signal periods.....	142
9.3.4	Display of measurement results.....	143
9.3.5	Adjusting the diagram view.....	147
9.3.6	Saving recorded data to a file.....	148
9.3.7	Loading recorded data from a file.....	148
9.3.8	Exporting recorded data.....	149
9.4	Checking voltage supply.....	150
9.4.1	Voltage display function.....	150
9.4.2	Deactivating the terminating resistor.....	151
9.5	Displaying and copying encoder information.....	152
9.5.1	Encoder information function.....	152

10 Inspecting encoders with square-wave incremental signals.....	153
10.1 Overview.....	154
10.2 Checking incremental signals.....	155
10.2.1 Incremental signal function.....	155
10.2.2 Level view.....	156
10.2.3 Checking incremental signals (Level view).....	159
10.2.4 Checking the reference signal (Level view).....	163
10.2.5 Logic view.....	164
10.2.6 Performing logic analysis (Logic view).....	169
10.2.7 Counter view.....	172
10.2.8 Checking the counting function (Counter view).....	175
10.2.9 Homing – Limit view.....	180
10.2.10 Checking limit switching signals (Homing – Limit view).....	183
10.2.11 Protocol view.....	185
10.2.12 Saving log data (Protocol view).....	186
10.2.13 Note view.....	187
10.2.14 Displaying and deleting notes (Note view).....	188
10.3 Checking voltage supply.....	189
10.3.1 Voltage display function.....	189
10.3.2 Deactivating the terminating resistor.....	190
10.4 Displaying and copying encoder information.....	191
10.4.1 Encoder information function.....	191

11 Inspecting encoders with serial interface (EnDat 2.1, EnDat 2.2 and proprietary interfaces).....	193
11.1 Overview.....	194
11.2 Checking position values, transmission and encoder status.....	195
11.2.1 Position display function.....	195
11.2.2 Classification of the status messages.....	198
11.2.3 Switching between measured values view and position view.....	199
11.2.4 Converting the measured value into degrees.....	200
11.2.5 Clearing the incremental counter.....	201
11.2.6 Equating the incremental counter with the absolute position.....	202
11.2.7 Synchronizing the counters.....	203
11.2.8 Inverting the counting direction of the incremental counter.....	204
11.2.9 Setting datum shift.....	205
11.2.10 Checking the datum shift.....	208
11.2.11 Resetting a datum shift.....	209
11.2.12 Displaying status messages.....	209
11.2.13 Displaying operating status error sources.....	210
11.2.14 Resetting status messages.....	211
11.3 Checking incremental signals.....	211
11.3.1 Incremental signal function.....	211
11.4 Checking voltage supply.....	212
11.4.1 Voltage display function.....	212
11.4.2 Deactivating the terminating resistor.....	213
11.5 Displaying and copying encoder information.....	214
11.5.1 Encoder information function.....	214
11.6 Checking the agreement of absolute track and incremental track.....	215
11.6.1 Absolute to incremental deviation function.....	215
11.6.2 Running the inspection.....	218
11.6.3 Inverting the counting direction of the incremental counter.....	219
11.6.4 Resetting the deviation span.....	219
11.7 Evaluating the encoder status with the online diagnostics.....	219
11.7.1 Online diagnostics function.....	219
11.7.2 Performing online diagnostics.....	227
11.7.3 Saving the log.....	232

11.7.4	Exporting data.....	232
11.7.5	Deleting values.....	232
11.8	Checking the functional safety of the encoder.....	233
11.8.1	Functional-safety encoder check.....	233
11.8.2	Saving the log.....	248
11.9	Loading and editing the encoder configuration.....	248
11.9.1	Display encoder memory function.....	249
11.9.2	Loading the encoder configuration from the encoder memory.....	251
11.9.3	Adapting the encoder configuration view.....	252
11.9.4	Saving the encoder configuration to a file.....	254
11.9.5	Saving encoder information to a file.....	254
11.9.6	Loading the encoder configuration from a file.....	254
11.9.7	Editing the encoder configuration.....	255
11.9.8	Overviews.....	261
11.10	Comparing encoder configurations.....	265
11.10.1	Comparison of encoder memory function.....	265
11.10.2	Loading and comparing encoder configurations.....	266
11.11	Saving the encoder memory.....	268
11.11.1	Save encoder memory function.....	268
11.11.2	Saving the encoder memory.....	269
11.12	Additional information Position value 2.....	269
11.12.1	Function Additional information Position value 2.....	269
11.12.2	Operating elements.....	271
11.13	Display of additional sensors.....	272
11.14	Measuring temperature.....	273

12 Inspecting encoders with serial interface of the EnDat 3 type.....	277
12.1 Overview.....	278
12.2 Performing EnDat 3 tests.....	279
12.2.1 Position display view.....	280
12.2.2 Online diagnostics screen.....	286
12.2.3 Encoder status view.....	294
12.2.4 Sensor technology view.....	295
12.2.5 ID label (EL) view.....	296
12.2.6 Configuration view.....	299
12.2.7 Wizards view.....	317
12.2.8 Operating status data view.....	325
12.2.9 Miscellaneous functions view.....	330
12.2.10 Saving log data.....	333
12.3 Checking the voltage supply.....	334
12.4 Checking encoders in bus mode.....	335
13 Special interface-specific functions.....	337
13.1 Overview.....	338
13.2 DRIVE-CLiQ.....	338
13.3 Fanuc.....	354
13.4 Mitsubishi.....	357
13.5 Panasonic.....	358
13.6 Yaskawa.....	359
13.7 SSI.....	361
13.8 Indramat.....	362

14	Optional special functions (software options)	363
14.1	Overview	364
14.2	Advanced DRIVE-CLiQ functions (software option 14)	364
14.2.1	Expanded parameter display function	364
14.2.2	Entering parameters individually	365
14.2.3	Showing all parameters	365
14.2.4	Switching to cyclic parameter display	365
14.2.5	Switching to acyclic parameter display	365
14.2.6	Saving the parameter list to a file	366
14.3	Adjusting the tolerance limits of incremental signals (software option 20)	366
14.3.1	Customizing view	367
14.3.2	Customizing tolerance limits	369
14.3.3	Saving tolerance limits to a file	371
14.3.4	Loading tolerance limits from a file	372
14.3.5	Resetting tolerance limits to default	372
14.4	Setting the datum shift on encoders with company-specific interfaces (software option 24)	373
14.5	Setting the datum shift on encoders with EnDat interfaces (software option 29)	373
15	What to do if	375
15.1	Overview	376
15.2	Troubleshooting	376
16	Index	378

1

Fundamentals

1.1 Overview

This chapter contains information about the product and this manual.

1.2 Information on the product

The Adjusting and Testing Software (ATS) is a component of an encoder diagnostic set. In combination with the testing and inspection devices of the PWM series, the Adjusting and Testing Software assists during mounting, functional checks and error diagnosis of HEIDENHAIN encoders. For this purpose, the Adjusting and Testing Software is installed on a computer and connected to the PWM.

Further information: "Overview of functions", Page 33

The Adjusting and Testing Software features an encoder database. The encoder database contains all ID numbers and variants of the encoders that existed when the software was released.

New versions of the Adjusting and Testing Software with an up-to-date encoder database are made available at regular intervals. You can find the current software version in the download area of the HEIDENHAIN website.

Further information: "Updating software and encoder database", Page 40

1.3 Software options

Software options are available to increase the range of functions of the Adjusting and Testing Software. You can enable software options in the Adjusting and Testing Software by entering a license key.

Further information: "Enabling software options", Page 53

1.4 Validity of the documentation

This User's Manual is valid for version 4.2.0 of the Adjusting and Testing Software.

- ▶ Before using the documentation, make sure that the documentation and software version match.

Further information: "Viewing software information", Page 47

Further information: "Updating software and encoder database", Page 40

1.5 Hardware compatibility

The Adjusting and Testing Software is compatible with the following hardware:

Hardware	ID
PWM 20	731626-01
PWM 21	1200635-01
PWM 3000	1315850-01

 PWM 20, PWM 21, and PWM 3000 will be referred to as **PWM** in this document. If a distinction is necessary, the specific hardware will be indicated.

 Special versions of the Adjusting and Testing Software and the associated documentation (e.g., for testing encoders with the IK 215) can be found at **www.heidenhain.com**.

 HEIDENHAIN recommends returning the product to the HEIDENHAIN calibration service every two years in order to ensure traceable, accurate and error-free operation.
After the recommended time period has expired, a corresponding message is displayed in the Adjusting and Testing Software.

1.6 Notes on reading this document

WARNING

Fatal accidents, personal injury or property damage caused by non-compliance with the documentation

Incorrect operation of the software may result in death, injury or property damage.

- ▶ Read the documentation carefully from beginning to end
- ▶ Keep the documentation



Be sure to have read and understood the documentation of the testing device and the encoder before connecting the Adjusting and Testing software to a testing device or encoder.

The table below lists the various parts of the documentation in their order of reading priority.

Documentation	Description
Addendum	An addendum supplements or supersedes the corresponding contents of the Operating Instructions and, if applicable, of the Installation Instructions. If an addendum is included in the shipment, it has the highest priority for reading. All other contents of the documentation retain their validity.
Mounting Instructions	The Mounting Instructions contain all the information and safety precautions needed for the proper mounting and installation of a product. Mounting Instructions are included in every delivery. Mounting Instructions have the second highest priority for reading.
Operating Instructions	The Operating Instructions contain all the information and safety precautions needed for the proper operation of the product according to its intended use. The Operating Instructions are included on the supplied storage medium and can also be downloaded from the download area at www.heidenhain.com . The Operating Instructions must be read prior to initial operation of the product. The Operating Instructions have the third highest priority for reading.
Software Release Notes	The Software Release Notes summarize the expansions and improvements implemented in the respective software version.
User's Manual	The User's Manual provides all information required for installing the software on a computer and for using it as intended. The User's Manual is located in the installation folder of the software and can be downloaded from the download area at www.heidenhain.com .

Would you like any changes, or have you found any errors?

We are continuously striving to improve our documentation for you. Please help us by sending your suggestions to the following e-mail address:

userdoc@heidenhain.de

1.7 Storage and distribution of the documentation

The User's Manual must be kept in the immediate vicinity of the workplace and must be available to all personnel at all times. The operating company must inform the personnel where the User's Manual is kept. If the User's Manual has become illegible, the operating company must obtain a new copy from the manufacturer.

If the software is passed on to any other party, the User's Manual must also be passed on to the new owner.

1.8 Target groups

The User's Manual is intended for specialists for service, maintenance and commissioning.

The activities described may be performed only by persons with profound knowledge of electronics, electrical engineering and NC machine-tool technology.

This User's Manual must be read and observed by any person involved in diagnosing or adjusting encoders with the Adjusting and Testing Software.

1.9 Symbols and fonts used for marking text

In these instructions the following symbols and fonts are used for marking text:

Format	Meaning
▶ ... > ...	Identifies an action and the result of this action Example: ▶ Tap OK > The message is closed
■ ... ■ ...	Identifies an item of a list Example: ■ TTL interface ■ EnDat interface ■ ...

1.10 Figures

This User's Manual contains illustrations for the purpose of explanation and illustration. The actual GUI depends on the software configuration and on the connected encoder.

1.11 More information

For detailed information on hardware and connection technology, refer to the following documentation:

Documentation available in the Adjusting and Testing Software:

- User's Manual "Cables and Connection Technology PWM 20 and PWM 21 (IK 215) Testing Package"
- "Interfaces of HEIDENHAIN Encoders" brochure
- PWM Operating Instructions

Further information: "Opening documentation", Page 47

Documentation of product manufacturers:

- Documentation of peripheral devices
- Documentation of the encoders
- Documentation of the machine tool

Documentation on EnDat:



For more information on EnDat 2.1, EnDat 2.2 and EnDat 3 refer to www.endat.de

2

Safety

2.1 Overview

This chapter provides important safety information needed for connecting the Adjusting and Testing Software to devices and for proper operation.

2.2 Notes in this documentation

Safety precautions

Precautionary statements warn of hazards in handling the device and provide information on their prevention. Precautionary statements are classified by hazard severity and divided into the following groups:

DANGER

Danger indicates hazards for persons. If you do not follow the avoidance instructions, the hazard **will result in death or severe injury**.

WARNING

Warning indicates hazards for persons. If you do not follow the avoidance instructions, the hazard **could result in death or serious injury**.

CAUTION

Caution indicates hazards for persons. If you do not follow the avoidance instructions, the hazard **could result in minor or moderate injury**.

NOTICE

Notice indicates danger to material or data. If you do not follow the avoidance instructions, the hazard **could result in property damage**.

Informational notes

Informational notes ensure reliable and efficient operation of the device. Informational notes are divided into the following groups:



The information symbol indicates a **tip**.
A tip provides important additional or supplementary information.



The gear symbol indicates a function that **depends on the machine**.
The function described depends on the machine if, for example:

- Your machine features a certain software or hardware option
- The behavior of the functions depends on the configurable machine settings





The book symbol indicates a **cross reference**.
A cross reference leads to external documentation, for example the documentation of your machine manufacturer or other supplier.

2.3 Safety precautions in the Adjusting and Testing Software

The Adjusting and Testing Software displays safety precautions by means of symbols.

Examples:

Icon	Note
	If the selected encoder does not match the connected encoder, the encoder or the computer may be damaged.
	Encoders which are subject to a laser protection class are marked accordingly. In this case, observe the information on the encoder, the encoder mounting instructions and all safety precautions contained therein.

2.4 Intended use

The Adjusting and Testing Software is intended solely for the following use:

- Diagnostics and adjustment of HEIDENHAIN encoders

2.5 Improper use

Any use not specified in 'Intended use' is considered improper use. The company operating the encoder diagnostic set is solely liable for any damage resulting from improper use.

Especially its use as part of a safety function is not permitted.

2.6 Personnel qualification

The personnel installing and operating the software must be appropriately qualified for this work and must have obtained sufficient information from the documentation supplied with the software, the devices and the connected peripherals.

The personnel groups are specified in detail as follows with regard to their qualifications and tasks.

Qualified personnel

The qualified personnel are trained by the operating company to perform operation and parameterization. The qualified personnel have the required technical training, knowledge and experience and know the applicable regulations, and are thus capable of performing the assigned work regarding the application concerned and of proactively identifying and avoiding potential risks.

Electrical specialist

The electrical specialist has the required technical training, knowledge and experience and knows the applicable standards and regulations, and is thus capable of performing work on electrical systems and of proactively identifying and avoiding potential risks. Electrical specialists have been specially trained for the environment they work in. Electrical specialists must comply with the provisions of the applicable legal regulations on accident prevention.

2.7 Obligations of the operating company

The operating company owns or leases the software, the devices, and the peripheral devices. It is responsible that the intended use is complied with at all times.

The operating company must:

- Assign the different tasks to be performed to appropriate, qualified, and authorized personnel
- Verifiably train the personnel in the authorizations and tasks
- Provide all materials and means necessary in order for the personnel to complete the assigned tasks
- Ensure that the devices are operated only when in perfect technical condition
- Ensure that the software and the devices are protected from unauthorized use

2.8 General safety precautions



The safety of any system incorporating the use of this product is the responsibility of the assembler or installer of the system.



The software supports the use of a wide variety of peripheral devices. The safety precautions provided in the respective documentations of the devices must be observed. If there is no documentation at hand, it must be obtained from the manufacturer concerned.

The specific safety precautions required for the individual activities to be performed are indicated in the respective sections of this manual.

3

**Inspecting encoders
with the encoder
diagnostic set**

3.1 Overview

This chapter provides basic information on inspecting encoders with the encoder diagnostic set.

3.2 Measuring methods and interfaces

The scope of functions of the Adjusting and Testing Software depends on the connected encoder, in particular on its measuring method and interface type.

Measuring method

The following measuring methods are available for HEIDENHAIN encoders:

Measuring method	Description
Incremental measuring method	With the incremental measuring method, the position information is obtained by counting the individual increments (measuring steps) starting from some point of origin. Since an absolute reference point is necessary for determining the positions, a reference-mark signal is output as well. As a general rule, encoders that operate with the incremental measuring method provide incremental signals.
Absolute measuring method	With the absolute measuring method the absolute position information is acquired directly from the grating of the measuring standard. The position value is available from the encoder immediately upon switch-on and can be requested at any time by the downstream electronics. Absolute encoders do not require referencing. Some absolute encoders output incremental signals in addition to the position value. Some absolute encoders transmit valuation numbers providing information on the current encoder status.

Interfaces

The following interface types can be distinguished, depending on the encoder output signal:

Sinusoidal incremental signals	Description
1 V _{PP} 3 V _{PP}	The encoder outputs voltage signals (sinusoidal signals).
11 μA _{PP} 25 μA _{PP}	The encoder outputs current signals (sinusoidal signals).
Square-wave incremental signals	Description
TTL HTL HTLs	The integrated electronics (with or without interpolation) digitizes the sinusoidal scanning signal and outputs it to the downstream electronics as a sequence of square-wave pulses.
Serial data transmission	Description
EnDat 2.1 EnDat 2.1, EnDat 2.2	<p>Digital, bidirectional interface that is capable of transmitting position values, reading and updating information stored in the encoder, and storing new information.</p> <p>The ordering designation indicates whether the encoder outputs incremental signals in addition to the absolute position:</p> <ul style="list-style-type: none"> ■ EnDat01, EnDat02: with 1 V_{PP} incremental signals ■ EnDat21, EnDat22: without incremental signals ■ EnDatTx: with TTL incremental signals ■ EnDatHx: with HTL incremental signals
EnDat 3	<p>EnDat 3 requires two wires for communication. For EnDat 3, usually two further wires are required to power the encoder. Since the digital data stream has no DC component, communication can be modulated onto the supply wires, thereby reducing the overall number of wires to just two for certain applications (e.g., for hybrid motor cables).</p> <p>Ordering designation of the encoder:</p> <ul style="list-style-type: none"> ■ E30-R2: Communication modulated onto the supply wires ■ E30-R2: Communication and separate supply wires ■ E30-RB: Bus operation (daisy chain) ■ E30-RM: Version with EnDat22 compatibility
DRIVE-CLiQ	Manufacturer-specific interfaces without incremental signals
Fanuc	
Mitsubishi	
Panasonic	
Yaskawa	

Serial data transmission	Description
Indramat	
SSI	Synchronous serial interface with incremental signals

Signal converter

Signal converters adapt the encoder signals to the interface of the downstream electronics. They are used when the downstream electronics cannot directly process the output signals encoders, or when the additional interpolation of the signals is necessary. The encoder diagnostic set allows you to test encoders in combination with different signal converters of the series **EIB**, **EXE**, **IBV**, and **APE**.

Transceiver unit for EnDat touch probes

Wireless touch probes transmit information via radio or infrared signals to a transceiver unit. With the encoder diagnostic set, you can test the EnDat touch probes **TS 460** and **TT 460** in combination with the transceiver unit **SE 661**.

The encoder diagnostic set currently does not support other touch probes or transceiver units.



For more information on the encoder interfaces, please refer to the **Interfaces of HEIDENHAIN Encoders** brochure.

The section "Encoder data groups" lists the data groups available for each interface and indicates if an additional software option is required for the testing device. If necessary, please contact HEIDENHAIN.

Further information: "Opening documentation", Page 47



You can find detailed information on the encoder interface in the encoder documentation that you can download from the HEIDENHAIN website www.heidenhain.com.

3.3 Operating modes of the testing device

The procedure for testing encoders depends on the operating mode of the testing device.

The following operating modes are available:

- **Encoder diagnostics:**

The encoder is connected directly to the PWM. This makes a comprehensive analysis of the encoder functions possible, irrespective of the control loop of a machine tool

- **Monitoring mode:**

The PWM is integrated into the control loop of an NC-controlled machine tool. This permits monitoring of the encoder during operation



For information about which interface types support monitoring, see the Overview of functions.

Further information: "Overview of functions", Page 33



Read the operating instructions before connecting and operating the PWM.

Further information: "Opening documentation", Page 47

3.3.1 Encoder diagnostics

Encoder diagnostics without signal adapter

The encoder is connected directly to the PWM. This makes a comprehensive analysis of the encoder functions possible, irrespective of the control loop of a machine tool.

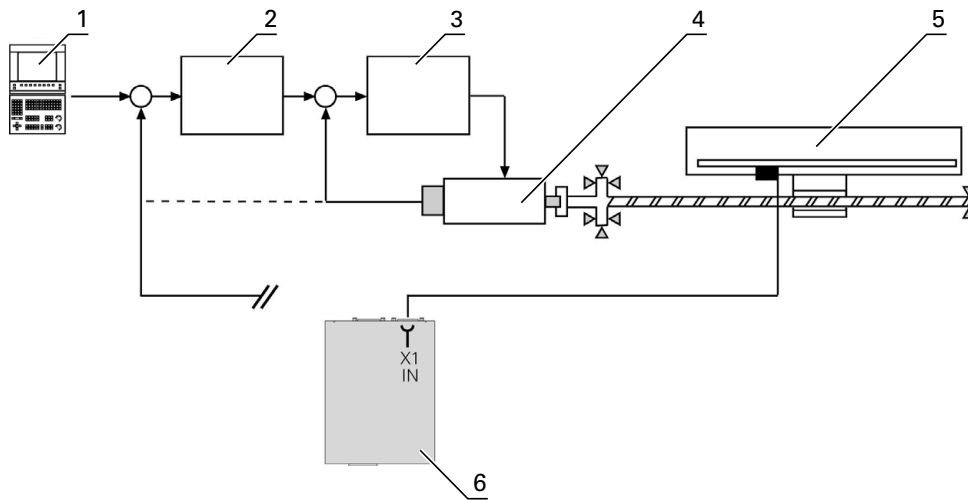

Figure 1: PWM connected directly to the encoder

- 1 Control
- 2 Position controller
- 3 Speed controller
- 4 Motor
- 5 Encoder
- 6 PWM

Property	Description
Connection of the PWM	<ul style="list-style-type: none"> ■ The encoder input X1 or X4 is connected to the encoder ■ The encoder input X2 is not connected
Power supply of the encoder	Via the PWM
<div style="border: 1px solid black; padding: 5px;"> <p>i If the power is supplied via the PWM, you can activate voltage readjustment in the Adjusting and Testing Software. This serves to compensate for voltage drops on the lines connecting the testing device and the encoder. The cabling between the testing device and the encoder must support voltage readjustment. The Adjusting and Testing Software may display a corresponding message.</p> </div>	
Encoder traverse	Usually by hand; NC control is possible

Encoder diagnostics with signal adapter

The PWM is connected to the encoder via the signal adapter.

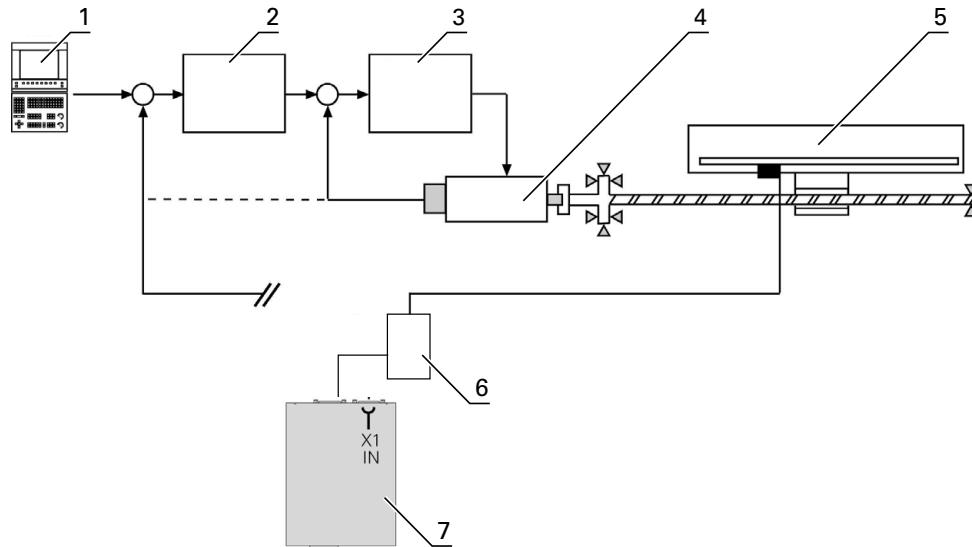

Figure 2: Encoder diagnostics with signal adapter

- 1 Control
- 2 Position controller
- 3 Speed controller
- 4 Motor
- 5 Encoder
- 6 Signal adapter
- 7 PWM

Property	Description
Connection of the PWM	<ul style="list-style-type: none"> ■ The encoder input X1 is connected to the signal adapter ■ The encoder input X2 is not connected
Power supply of the encoder	Via the PWM
Power supply of the signal adapter	Via the PWM
Encoder traverse	Usually by hand; NC control is possible

3.3.2 Monitoring mode

The PWM is integrated into the control loop of an NC-controlled machine tool. This permits monitoring of the encoder and the machine during operation.

i The use of a signal adapter is advisable for the monitoring mode. The signal adapter ensures metallic isolation and enables floating testing. The SA 100 and SA 110 signal adapters are designed for a maximum supply voltage of 5.5 V. For this reason, we recommend using the SA 2380 signal adapter.

b Detailed information on the SA 2380 signal adapter can be found in the corresponding operating instructions.

- ▶ www.heidenhain.com/documentation
- ▶ Enter the document ID **1386017**

For detailed information on the signal adapters SA 100 and SA 110, refer to the User's Manual "**Cables and Connection Technology PWM 20 and PWM 21 (IK 215) Testing Package**".

Further information: "Opening documentation", Page 47

i Touch probes currently do not support testing in monitoring mode.

Monitoring mode with signal adapter

The PWM is integrated into the control loop of the machine tool via the signal adapter. The test can be carried out potential-free.

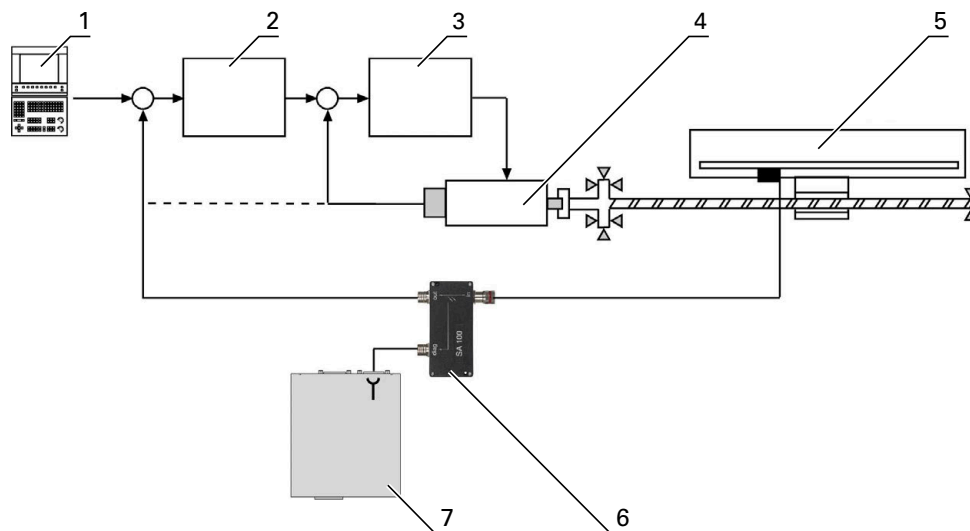

Figure 3: Monitoring mode with signal adapter (potential segregation)

- 1 Control
- 2 Position controller
- 3 Speed controller
- 4 Motor
- 5 Encoder
- 6 Signal adapter
- 7 PWM

Property	Description
Connection of the PWM	<ul style="list-style-type: none"> The encoder input X1 is connected to the signal adapter The encoder input X2 is not connected
Power supply of the encoder	Via the downstream electronics
Power supply of the signal adapter	Via the PWM
Potential segregation	By the signal adapter
Encoder traverse	NC control possible

Monitoring mode without signal adapter

The PWM is directly integrated into the control loop of the machine tool.

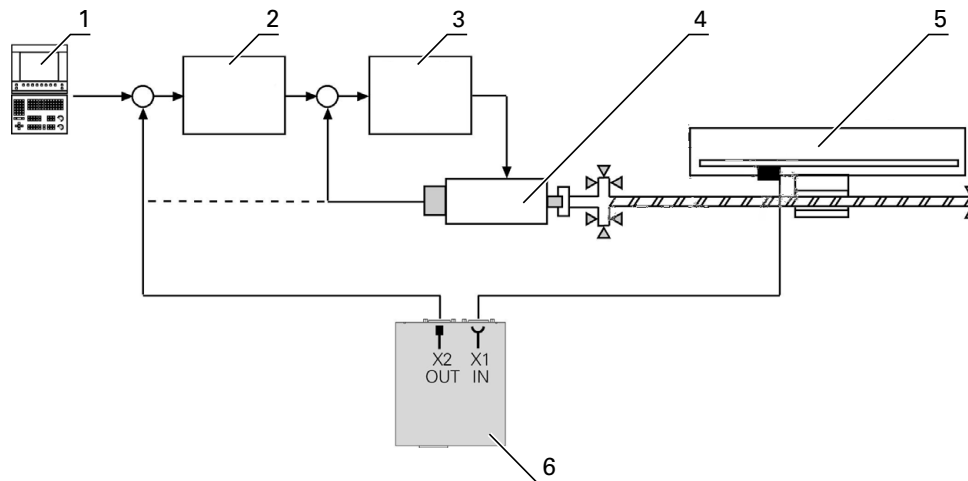

Figure 4: Monitoring mode without signal adapter (no potential segregation)

- 1 Control
- 2 Position controller
- 3 Speed controller
- 4 Motor
- 5 Encoder
- 6 PWM

Property	Description
Connection of the testing device	<ul style="list-style-type: none"> The encoder input X1 is connected to the encoder device The encoder input X2 is connected to the downstream electronics
Power supply of the encoder	Via downstream electronics
Potential segregation	No
Encoder traverse	NC control possible

The following interface-specific properties apply when using the monitoring mode without a signal adapter:

Interface	Characteristic
1 V _{PP}	<ul style="list-style-type: none"> ■ The PWM picks off the signals without 120-ohm signal termination ■ The cutoff frequency is influenced by the test setup (e.g., adapter cables)
11 μA _{PP}	<ul style="list-style-type: none"> ■ The line is interrupted in the monitoring mode, i.e. the PWM has an 11 μA_{PP} receiver and reproduces the (emulated) input signals at an 11 μA_{PP} output ■ The cutoff frequency is influenced by the test setup (e.g., adapter cables) ■ Signal interferences can occur, depending on the test setup (cable lengths, extension cables, cable configuration, machine type such as EDM)
TTL	<ul style="list-style-type: none"> ■ Without PWT switchover: The PWM picks off the RS-422 signals (a standard RS-422 receiver without 120-ohm terminating resistor is connected to the lines)
Serial	<ul style="list-style-type: none"> ■ The PWM picks off the RS-485 signals (a standard RS-485 receiver without 120-ohm terminating resistor is connected to the lines)

3.3.3 Signal adapter for EnDat 3 interface type

Depending on the version of the testing device, a signal adapter with an interface of the EnDat 3 type is required for certain encoders:

Ordering designation of the encoder	PWM 20	PWM 21	PWM 3000
E30-R2	SA 2380	SA 1210 or SA 2380	– ¹⁾
E30-R4	SA 2380	– ¹⁾	– ¹⁾
E30-RM	SA 2380	– ¹⁾	– ¹⁾
E30-RB	SA 2380	SA 2380 required only if the PWM cannot provide maximum power	

¹⁾ Signal adapter not required

 The SA 100 and SA 110 signal adapters are designed for a supply voltage of 5.5 V maximum; thus they are not suitable for testing encoders with EnDat 3 interface.

3.3.4 Bus operation

The Adjusting and Testing Software supports encoder diagnosis in EnDat 3 bus operation (daisy chain). Several participants are connected to the testing device in a bus chain.

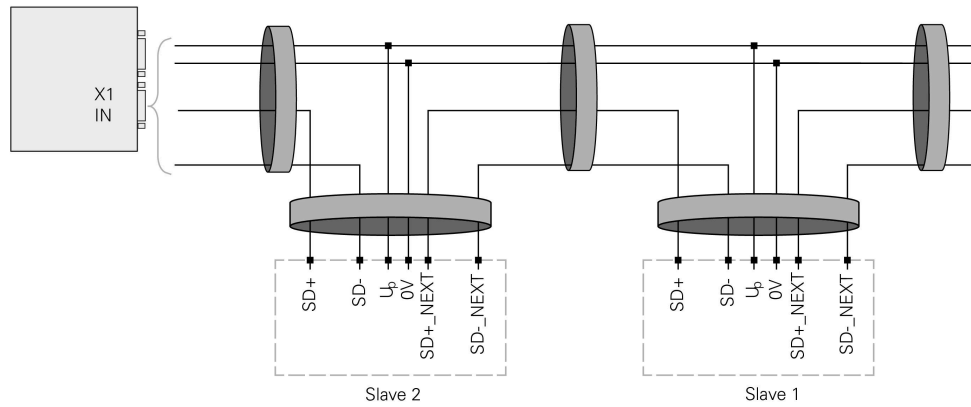

Figure 5: Bus chain (daisy chain) with several participants



Observe the maximum power the PWM used can provide. A signal adapter, e.g. SA 2380, and an external power supply unit may be required. Contact HEIDENHAIN for more information.

3.4 Overview of functions

The following overview shows the range of functions of the encoder diagnostic set with PWM 3000 depending on the encoder interface (if supported by the encoder).

	EnDat 3	EnDat 2.2	EnDat 2.1	1 V _{pp} / 11 μApp ²⁾	TTL	HTL ³⁾	DRIVE-CLiQ	Fanuc	Mitsubishi	Panasonic	Yaskawa	SSI
Diagnostics												
Display of online diagnostics	✓	✓	-	-	-	-	✓	✓	✓	✓	✓	-
Display of online diagnostics in the control loop ¹⁾	✓	✓	-	-	-	-	-	✓	✓	✓	-	-
Monitoring mode permitted with the PWM 3000	✓	✓	✓	✓	✓	-	-	✓	✓	✓	-	-
Display of operating status data	✓	-	-	-	-	-	-	-	-	-	-	-
Display of encoder information	✓	✓	✓	✓	✓	✓	✓	✓	✓	✓	✓	✓
Display of incremental signals in circular diagram	-	-	✓	✓	✓	-	-	-	-	-	-	✓
Evaluation of the reference signal	-	-	-	✓	✓	✓	-	-	-	-	-	-
Incremental counter	-	-	✓	✓	✓	✓	-	-	-	-	-	-
Display of supply voltage and supply current	✓	✓	✓	✓	✓	✓	✓	✓	✓	✓	✓	✓
Homing/limit display	-	-	-	✓	✓	-	-	-	-	-	-	-
Signal recording	-	-	-	✓	-	-	-	-	-	-	-	-
Connection dialog; encoder connection via:												
ID of encoder	✓	✓	✓	✓	✓	✓	✓	✓	✓	✓	✓	✓
Entry of interface and supply voltage	✓	✓	✓	✓	✓	✓	✓	✓	✓	✓	✓	✓
ID of HEIDENHAIN motor	✓	✓	✓	✓	-	-	-	-	-	-	-	-
Position display												
Display of absolute positions	✓	✓	✓	-	-	-	✓	✓	✓	✓	✓	✓
Support of daisy chain bus	✓	-	-	-	-	-	-	-	-	-	-	-
Display of the incremental position (if available)	✓	✓	✓	✓	✓	✓	-	✓	✓	-	-	✓
Display and resetting of error messages	✓	✓	✓	-	-	-	✓	✓	✓	✓	✓	-
Display and resetting of warnings	✓	✓	✓	-	-	-	✓	✓	✓	✓	✓	✓
Display of the transmission status	✓	✓	✓	-	-	-	✓	✓	✓	✓	✓	(✓)
PWT display of incremental signals	-	-	-	✓	(✓)	-	-	-	-	-	-	-

	EnDat 3	EnDat 2.2	EnDat 2.1	1 V _{pp} / 11 μA _{pp} ²⁾	TTL	HTL ³⁾	DRIVE-CLIQ	Fanuc	Mitsubishi	Panasonic	Yaskawa	SSI
Mounting wizards/ inspection wizards												
Mounting wizards	See "Mounting wizards"; for more information refer to the encoder documentation.											
Inspection wizard for encoders with functional safety	✓	✓	✓	-	-	-	✓	-	-	-	-	-
Tape tensioning wizard	-	✓	✓	✓	-	-	-	✓	✓	-	-	-
Miscellaneous functions (M functions)												
Comparison of absolute position with incremental position	-	-	✓	-	-	-	-	-	-	-	-	✓
Datum shift ("electric zeroing"), including information display ⁴⁾	(✓)	(✓)	(✓)	-	-	-	(✓)	(✓)	(✓)	(✓)	(✓)	(✓)
Configuration wizard (addresses, sensor characteristics, etc.)	✓	-	-	-	-	-	-	-	-	-	-	-
Display of temperatures	✓	✓ ⁵⁾	-	-	-	-	✓	✓	-	-	-	-
Display of further position values	✓	✓	-	-	-	-	✓	-	-	-	-	-
Display of further sensors	✓	✓	-	-	-	-	-	-	-	-	-	-
Display of limit position signals	✓	✓	-	-	-	-	-	-	-	-	-	-
Expanded parameter display	✓	✓	-	-	-	-	-	-	-	-	-	-
Memory contents												
Display of memory contents and memory parameters	✓	✓	✓	-	-	-	✓	✓	-	-	✓	-
Modification of memory contents	✓	✓	✓	-	-	-	-	-	-	-	-	-
Storing of memory assignments	✓	✓	✓	-	-	-	✓	-	-	-	-	-
Comparison of current memory contents with saved memory contents	✓	✓	✓	-	-	-	-	-	-	-	-	-
Backing up of the encoder memory	✓	✓	✓	-	-	-	✓	✓	✓	✓	✓	-

1) In monitoring mode; preferably in combination with a signal adapter

2) 25 μA_{pp}/3 V_{pp} for servicing purposes

3) Via signal adapter, for servicing purposes

4) Product key is required and is available only for certain encoders

5) Including conversion for PT 1000 sensors when EnDat memory parameters are appropriately set

(✓) See information in this User's Manual

3.5 Transfer of values and signals

Which values and signals the encoder transfers and the Adjusting and Testing Software evaluates depends on both the encoder interface and the operating mode of the testing device.

Interface	Transmission	In Encoder Diagnostics mode of operation	In Monitoring mode of operation
EnDat 3	Position value	Yes	Yes
	Valuation numbers	Yes	Yes
EnDat 2.1 (with incremental signals)	Position value	Yes	No
	Incremental signals	Yes	Yes
EnDat 2.2 (without incremental signals)	Position value	Yes	Yes
	Valuation numbers	Yes	Yes ¹⁾
DRIVE-CLiQ	Position value	Yes	No
	Valuation numbers	Yes	No
Fanuc	Position value	Yes	Yes
	Valuation numbers	Yes	Yes
Mitsubishi	Position value	Yes	Yes
	Valuation numbers	Yes ⁴⁾	Yes ^{1) 4)}
Panasonic	Position value	Yes	Yes
	Valuation numbers	Yes	Yes ¹⁾
Yaskawa	Position value	Yes	No
	Valuation numbers	Yes ⁵⁾	No
SSI	Position value	Yes	No
	Incremental signals	Yes	Yes
1 V _{PP}	Incremental signals	Yes	Yes
11 μA _{PP}	Incremental signals	Yes	Yes
TTL	Incremental signals	Yes	Yes
	Scanning signals	Yes ³⁾	No
HTL	Incremental signals	Yes ²⁾	No
Commutation	Block commutation	Yes ²⁾	No
	Sinusoidal commutation	Yes	Yes

- 1) Information must be requested and transferred by the control
- 2) Via appropriate signal adapter
- 3) If supported by the encoder (PWT function)
- 4) Not available for encoders with the ordering designation Mitsu01
- 5) Not available for the EIB 3391 Y

3.6 Units and tolerances

The Adjusting and Testing Software automatically adapts units, scalings, and tolerances to the connected encoder.

The tolerance values displayed in the Adjusting and Testing Software are the HEIDENHAIN standard values for the encoder interface concerned.

i For more information on signal amplitudes and tolerances, please refer to the "Interfaces of HEIDENHAIN Encoders".
Further information: "Opening documentation", Page 47

i The tolerances of high-accuracy measuring systems (e.g., angle encoders) and encoders with large temperature ranges (e.g., motor encoders) are tighter. In these cases, the tolerances of the Adjusting and Testing Software are invalid.

- ▶ Observe the tolerance specifications in the documentation of the encoder for each test

i A license key (software option) is required to alter the tolerance limits in the Adjusting and Testing Software.
Further information: "Software options", Page 14

Revolutions

Multiturn encoders transmit the number of revolutions in addition to their singleturn position.

m = Number of distinguishable revolutions

Value range according to specification	0 ... $m-1$ revolutions
--	-------------------------

Value range displayed on the product:	1 ... m revolutions
---------------------------------------	-----------------------

i Revolution 0 in the specification corresponds to revolution 1 in the product's display.

Typical gear-based multiturn encoders have 12 bits available for the transmission of the multiturn value. Therefore:

Number of distinguishable revolutions	$m = 2^{12} = 4096$ revolutions
---------------------------------------	---------------------------------

Value range according to specification	0 ... 4095 revolutions
--	------------------------

Value range displayed on the product:	1 ... 4096 revolutions
---------------------------------------	------------------------

4

**Installing the
software**

4.1 Overview

This chapter provides all of the information needed for downloading and properly installing the software and the necessary drivers on a computer.

4.2 System requirements

Computer:	IBM PC or compatible PC ≥ Pentium Dual Core; 2 GHz
Operating system:	<ul style="list-style-type: none"> ■ Microsoft Windows 7 (32/64 bits) ■ Microsoft Windows 8 (32/64 bits) ■ Microsoft Windows (32/64 bits) ■ Microsoft Windows 11 (64 bits)
RAM:	≥ 2 GB
Hard disk:	≥ 500 MB (1 GB) of free disk space
Monitor	≥ 1024 x 768 pixels
Interface:	PWM 20, PWM 21: USB 2.0 Type A PWM 3000: Ethernet as per IEEE 802.3 (10/100/1000 Mbit/s)
Windows user right:	Administrator



If the computer does not meet the described requirements, the consequences may be as follows:

- Data processing takes more time
- The Adjusting and Testing Software issues error messages
- The functionality of the Adjusting and Testing Software is reduced

4.3 Installing the software

You will find the installation files of the Adjusting and Testing Software in the download area of the HEIDENHAIN website.

Link:	www.heidenhain.com/service/downloads/software/
Category:	Inspection and testing devices
Product family:	PWM 20 / PWM 21 / PWM 3000
Product:	ATS Vx.x.xx – Adjusting and Testing Software for PWM



Read the release notes for the software version before installing the Adjusting and Testing Software. You will find the **ReleaseNotes.pdf** file in the folder of the installation file.

- ▶ Download the installation file from the HEIDENHAIN website
- ▶ Extract the downloaded ZIP file
- ▶ Navigate to the following folder: 539862xx ▶ FILES ▶ Software
- ▶ Run the installation file with the extension ".exe"
- > The installation wizard opens.
- ▶ Click **Next**
- ▶ In the **Select Destination Location** installation step, select the storage location to which you want to save the software



In the **Select Destination Location** installation step, the installation wizard suggests an installation directory. We recommend retaining the standard installation directory. All paths stated in this User's Manual refer to the standard installation directory.

- ▶ Click **Next**
- ▶ Click **Install**
- > The installation starts.
- > The status of installation is shown in the progress bar.
- ▶ When the installation is terminated, click **Finish**
- > The link to the Adjusting and Testing Software appears on the desktop.

4.4 Checking the installation

After the installation, check whether the Adjusting and Testing Software can access the PWM.

- ▶ Connect the PWM to the computer via the USB or Ethernet interface
- ▶ Switch on the PWM
- ▶ Start the Adjusting and Testing Software
Further information: "Starting the software", Page 46
- > If drivers are missing, the Adjusting and Testing Software issues the error message "No hardware was found."
Further information: "PWM 20, PWM 21: Installing drivers", Page 40

4.5 PWM 20, PWM 21: Installing drivers

The required drivers are located in the software installation folder.



Depending on the operating system of the computer, the procedure may differ from the description below.

- ▶ Navigate to the following folder in the installation package:
539862xx/FILES/Drivers/PWMxx
- ▶ Copy the driver files to the following program directory:
C: ▶ Programs (x86) ▶ HEIDENHAIN ▶ ATS ▶ Drivers ▶ PWM20_PWM21
- ▶ Call the device manager of the computer
- ▶ Click **Other devices**
- ▶ Double-click **PWM**
- ▶ Click **Update drivers**
- ▶ Select the option for manual search and installation
- ▶ In the dialog, enter the storage location of the driver files
- ▶ Click **Next**
- > The drivers will now be installed

4.6 PWM 3000 network settings



For information on network settings and requirements to the network environment, please refer to the **PWM 3000 Operating Instructions**, chapter "Connecting a computer".

- ▶ www.heidenhain.com/documentation
- ▶ Enter the document ID **1448758**

4.7 Updating software and encoder database

New versions of the Adjusting and Testing Software are made available at regular intervals. When you run a software update, the encoder database is updated as well. You find the current software version in the download area at the HEIDENHAIN website.

Link: www.heidenhain.com/service/downloads/software/
Category: Inspection and testing devices
Product family: PWM 20 / PWM 21 / PWM 3000
Product: ATS Vx.x.xx – Adjusting and Testing Software for PWM

4.8 Uninstalling the software

To uninstall the Adjusting and Testing Software from a computer, proceed as follows:

- ▶ Select the following in succession in Microsoft Windows:
 - **Start**
 - **HEIDENHAIN Applications**
 - **Adjusting and Testing Software**
- ▶ Click **Uninstall**
- > The uninstallation wizard opens.
- ▶ To confirm uninstalling, click **Yes**
- > Uninstalling starts
- > The status of the uninstall process is shown in the progress bar.
- ▶ After uninstallation has been completed successfully, close the uninstallation wizard with **OK**

5

Basic operation

5.1 Overview

This chapter describes the user interface, operating elements and basic functions of the Adjusting and Testing Software.

5.2 Structure of the user interface

The software is operated via a function menu. The functions in the function menu are combined in function groups.

i The range of functions depend on the connected encoder and on the software configuration. When you connect an encoder, all functions are displayed that are available for this encoder.

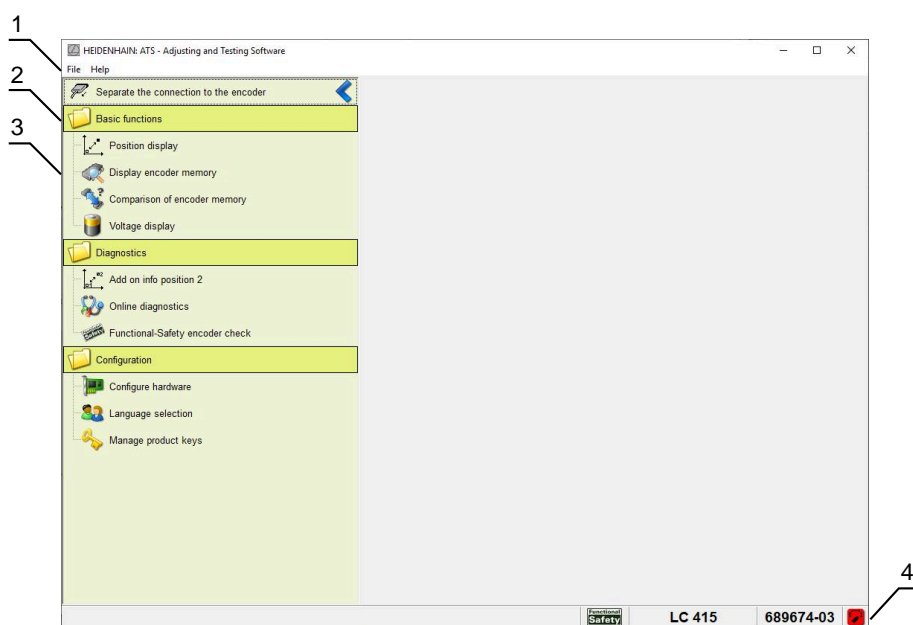
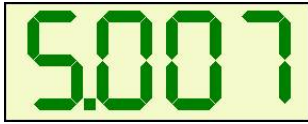

Figure 6: User interface after connecting an encoder

- 1 Menu bar with the menus **File** and **Help**
- 2 Function group
- 3 Function
- 4 Information bar showing information on the connected encoder

5.3 Recurring displays and operating elements

Display of values



Values are displayed as colored numerals. The significance of the color depends on the function. For a detailed description, please refer to the respective section.

Status display



The color of the LED symbol indicates a status, e.g.:

- Green: Measured value within the tolerance range
- Red: Measured value outside the tolerance range

The significance of the color depends on the function. For a detailed description, please refer to the respective section.

Bar graph

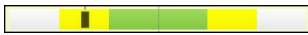

Bar graphs serve to display and evaluate measured values. The significance of the color depends on the function. For a detailed description, please refer to the respective section.

Input fields with plus and minus operating elements



- ▶ Enter the desired value
- ▶ Confirm with **Enter**
- or
- ▶ Tap + or – until the desired value is displayed
- ▶ Press and hold + or – to change values faster



Operating element "Return to last view"



Return to the previous level or back to the main menu

Symbols: Power supply

The symbols indicate whether power supply by the PWM is active.

Display	Description
	Power supply is not active
	Power supply is active

i When the computer goes into sleep mode or if there is a software error, the display in the Adjusting and Testing Software is no longer reliable. Therefore always observe the **L2** status LED on the PWM to see whether the PWM is outputting voltage. You will find a detailed description of the PWM status displays in the operating instructions.

Further information: "Opening documentation", Page 47

Mouse-over text

When you move the mouse pointer over operating elements or displays, a mouse-over text appears, giving a brief explanation, such as the unit of a value.

5.4 Starting the software



- ▶ Double-click the icon of the Adjusting and Testing Software on the Microsoft Windows desktop
or
- ▶ Select in succession in Microsoft Windows
 - **Start**
 - **HEIDENHAIN Applications**
 - **ATS – Adjusting and Testing Software**
- > The software opens.

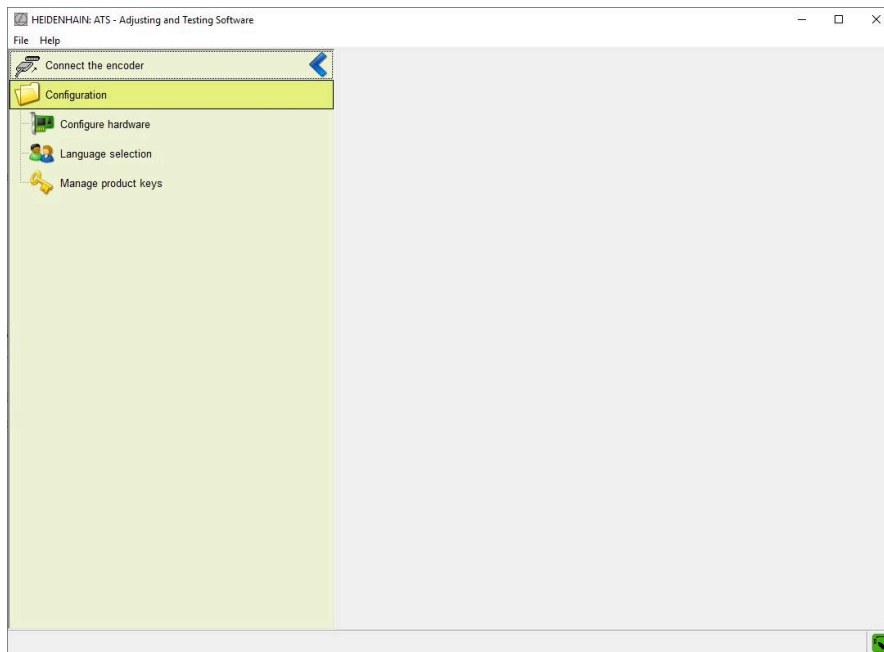

Figure 7: User interface after startup

Firmware update

If the PWM is switched on and connected to the computer, the Adjusting and Testing Software checks the compatibility of the firmware of the device and the current software version. If a firmware update is required, you can run the update with the Adjusting and Testing Software. A software wizard will guide you through the required steps.

NOTICE

Damage to the product by interrupting a firmware update

If you disconnect the power supply of the PWM or separate the plug connection during a firmware update, the PWM may be damaged.

- ▶ When updating the firmware, wait until the progress bar has reached 100% before you continue with further steps

5.5 Exiting the software

- ▶ Click **File** on the menu bar
- ▶ Click **Exit**
- > If the software is connected to an encoder, the connection is separated.
- > The software is closed.

5.6 Viewing software information

Display of information on software and database versions

- ▶ Click **Help** on the menu bar
- ▶ Click **About**
- > Information on the installed software version and database version is displayed.



You can download the current software version from the HEIDENHAIN website.

Further information: "Updating software and encoder database", Page 40

Display of license information on open source software

- ▶ Click **Help** on the menu bar
- ▶ Position the mouse pointer at **License hints**
- ▶ Click **Used Open Source Software**
- > The license information about the open-source software being used is displayed.

5.7 Opening documentation

Precondition: A PDF viewer is installed on the computer.

The following documents are available in the software in PDF format:

File name in the Help menu	Document
User's Manual	User's Manual "Adjusting and Testing Software (ATS)"
Cables and Connection Technology	User's Manual "Cables and Connection Technology PWM 20 and PWM 21 (IK 215) Testing Package"
Interfaces	Brochure "Interfaces of HEIDENHAIN Encoders"
Operating Instructions	Operating Instructions "PWM 20 and PWM 21" Operating Instructions "PWM 3000"
Release Notes	Release Notes for the installed version of the Adjusting and Testing Software

- ▶ Click **Help** on the menu bar to open a document
- ▶ Click the file name
- > The document is opened in the PDF viewer.

Documentation on EnDat:



For more information on EnDat 2.1, EnDat 2.2 and EnDat 3 refer to www.endat.de

5.8 Adjusting, exporting and printing diagrams

Some of the views of the Adjusting and Testing Software contain diagrams. You can adjust the diagram views and export and print diagrams.

5.8.1 Magnifying the diagram view

- ▶ Press and hold the left mouse button and – starting at the left – draw a square over the desired area
- > This area will be magnified.

5.8.2 Moving an image section

When the diagram view is zoomed in, you can navigate in the diagram by moving the image section.

- ▶ To move the image section vertically, press and hold the left mouse button and turn the scroll wheel in the desired direction
- ▶ To navigate freely, move the diagram to the desired position while holding down the right mouse button

5.8.3 Reducing the diagram view

- ▶ Press and hold the left mouse button and draw a square from right to left
- > The diagram view is reduced in size.

5.8.4 Exporting diagrams

The Adjusting and Testing Software uses the **TeeChart** program offering the following export functions:

- Copy diagram to clipboard
- Save diagram
- Send diagram by e-mail
- ▶ Right-click the diagram
- ▶ Click **Save diagram**
- > The **Save** dialog appears.

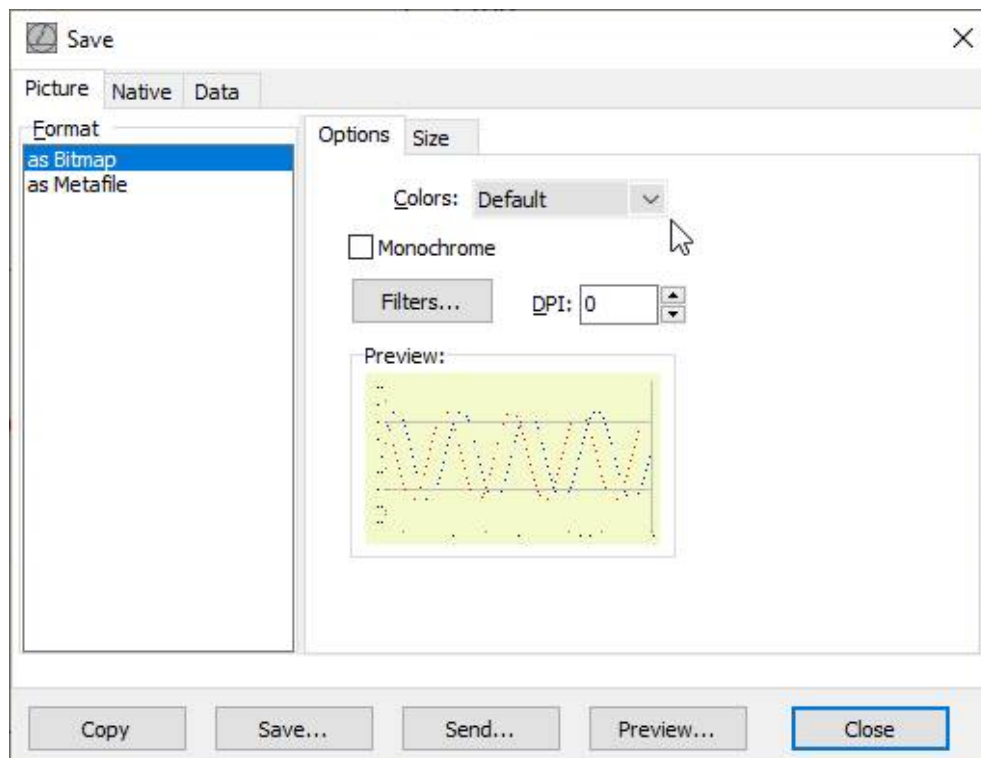

Figure 8: **Save** dialog

- ▶ Select the desired parameters
- ▶ Click **Preview** to open the preview of the diagram
- ▶ Click **Copy** to copy the diagram to the clipboard
- ▶ Click **Save** to save the diagram to the local disk
- ▶ Click **Send** to send the diagram by e-mail
- ▶ Follow the instructions of the Windows dialog

5.8.5 Printing the diagram

- ▶ Right-click the diagram
- ▶ Click **Print diagram**
- > The dialog **TeeChart Print Preview** appears.

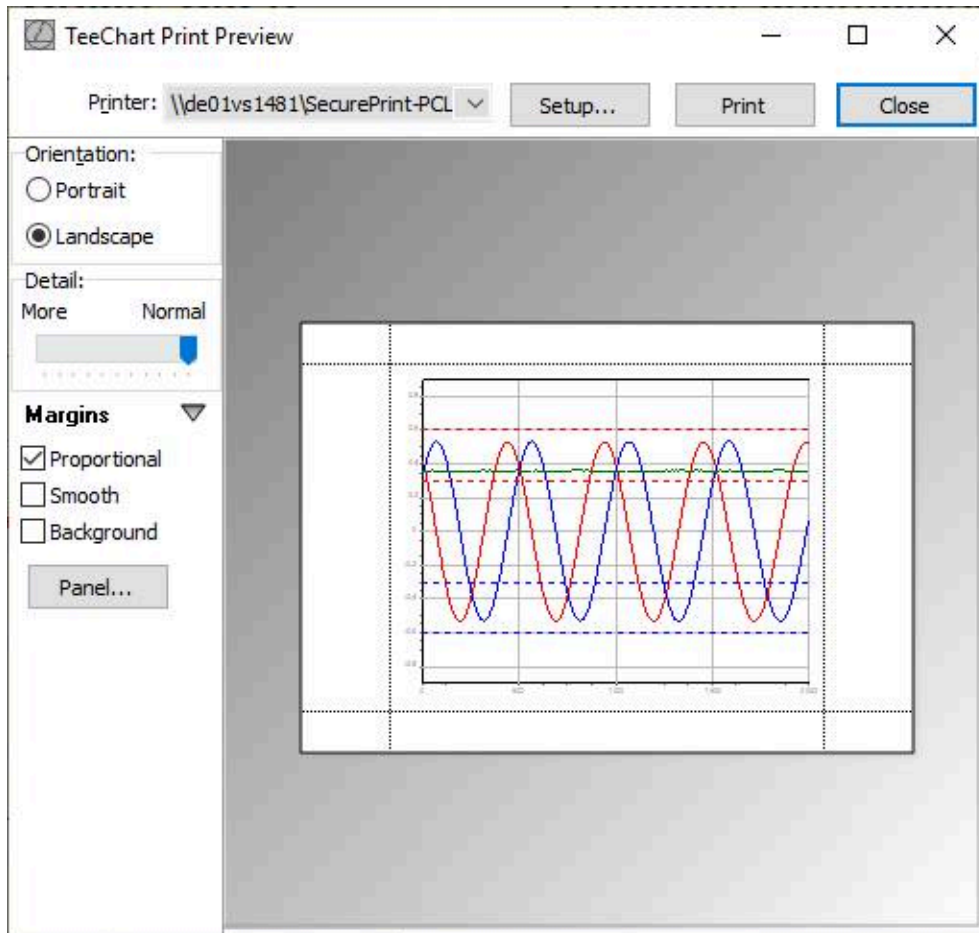

Figure 9: Dialog **TeeChart Print Preview**

- ▶ Select the desired parameters
- ▶ Click **Print**
- > The print job is sent to the selected printer.

6

**Configuring the
software**

6.1 Overview

This chapter describes how you can adapt the Adjusting and Testing Software to your requirements.

6.2 Switching the language

You can change the language of the user interface.

- ▶ Double-click **Language selection** in the function menu
- ▶ Click the desired national flag symbol
- ▶ Confirm with **OK**
- > The user interface is displayed in the selected language.

6.3 Enabling software options

Software options are available to increase the range of functions of the Adjusting and Testing Software. A product key must be entered to enable a software option. You can obtain the required product key from HEIDENHAIN.

i Product keys are associated with the serial number of the device. Software options cannot be transferred to other devices.

i Multiple software options can be activated per serial number. There are various product keys, with different validity periods:

- Permanent
- Limited time (usually one year)
- Test license (usually one month)

- ▶ Double-click **Manage product keys** in the function menu
- ▶ The **Product keys** dialog appears.

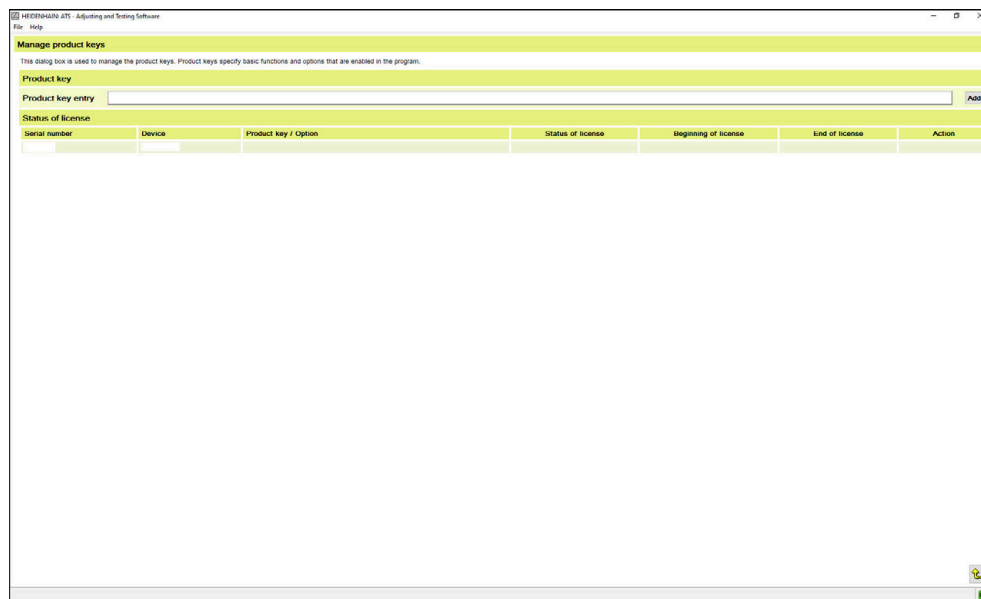

Figure 10: **Product keys** dialog

- ▶ Enter the product key
- ▶ Click **Add**
- ▶ The software option is displayed in the **Status of license** field.
- ▶ Click **Close**
- ▶ The additional functions will be available as soon as you connect an encoder supporting these functions.

6.4 Deactivating software options

When you deactivate a software option, the associated functions will no longer be available. You can reactivate the software option at the same device by re-entering the product key.

- ▶ Double-click **Manage product keys** in the function menu
- ▶ The **Product key** dialog shows the active software options for each serial number.

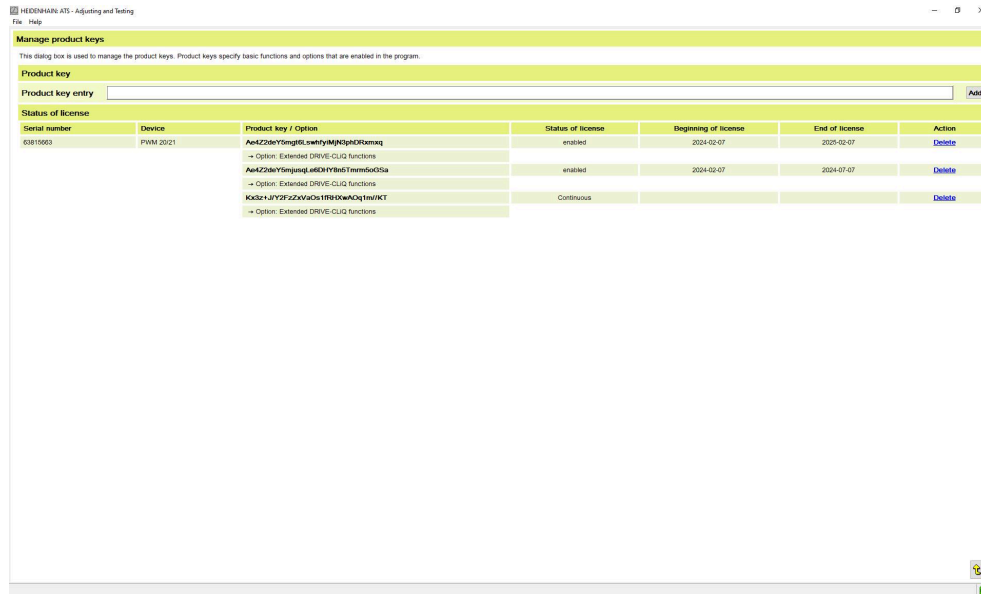

Figure 11: The **Product key** dialog with activated software options

- ▶ Click **Delete** next to the desired software option
- ▶ Confirm with **Yes**
- ▶ The software option is deactivated.

6.5 Updating the documentation

The files listed below are stored in the Adjusting and Testing Software and can be replaced by new file versions.

File name	Document
um.pdf	User's Manual "Adjusting and Testing Software (ATS)"
cct.pdf	User's Manual "Cables and Connection Technology PWM 20 and PWM 21 (IK 215) Testing Package"
i.pdf	Brochure "Interfaces of HEIDENHAIN Encoders"
oi.pdf	Operating Instructions "PWM 20 and PWM 21" Operating Instructions "PWM 3000"

You can download the current documentation from the HEIDENHAIN website.

Link: www.heidenhain.com/documentation

- ▶ To store new documents in the Adjusting and Testing Software, open the program directory and navigate to the storage location you selected during the software installation:
Path: C: ▶ Programs (x86) ▶ HEIDENHAIN ▶ ATS ▶ doc
- > The program directory contains a folder for each language in which the documentation is available.
- ▶ Open the folder for the desired language
- ▶ Replace the existing files with the new files

 The file names must be as specified in the table.

- ▶ Repeat for other languages, if required
- > The new documents are available in the **Help** menu in the selected language.

6.6 Selecting the PWM as testing device

PWM 20, PWM 21

If your computer is connected to only one testing device, the Adjusting and Testing Software automatically selects this device; no further action is required.

Precondition:

- The PWM is connected to the computer via the USB or Ethernet interface
- The PWM is switched on
- The device drivers are installed

Further information: "PWM 20, PWM 21: Installing drivers", Page 40

Further information: "PWM 3000 network settings", Page 40

If your computer is connected to several testing devices, select the device you are currently working with in the Adjusting and Testing Software:

- ▶ Double-click **Configure hardware** in the function menu
- > The **Configure hardware** dialog appears.
- ▶ Check the box for the desired testing device
- ▶ Confirm with **OK**
- > The Adjusting and Testing Software will use the selected testing device.

PWM 3000

To connect a PWM 3000, proceed as follows:

- ▶ Click **Add**
- ▶ Enter the host name or IP address of the PWM 3000 in the **Slot** field
- ▶ Check the box for the desired testing device
- ▶ Confirm your entry with **OK**
- > The Adjusting and Testing Software will use the selected testing device.

Operating elements

Symbol	Function
	Settings Opens the PWM 3000 settings dialog

PWM 3000 settings

The **PWM 3000 settings** dialog shows the following information:

- Serial number
- IP address
- Network mask
- Gateway
- Hostname



- ▶ Click **Settings** to call the dialog
- > The dialog is displayed.

You may edit the settings.

6.7 Saving log information

You can save log files (PDF format) with test results in the functions **Incremental signal**, **Online diagnostics** and **Functional-Safety encoder check**. In the logs, you can add information on the company and the tester.



Figure 12: Custom log header

File templates are available for creating content. The templates are located in the following directory:

Path: C: ► Programs ► HEIDENHAIN ► ATS ► db ► cfg ► templates

The file templates are available:

File name	Description
AtsCustomerAddress.txt	Company address
AtsCustomerName.txt	Company name
AtsTesterName.txt	Name of the tester
AtsReportLogoLeft.png	Company logo on the left side
AtsReportLogoRight.png	Company logo on the right side
AtsSignatureLogo.png	Signature of the tester

- ▶ Create a new directory with the name "ATS" on drive "C:"
Path: C: ► ATS
- ▶ Copy the required file templates to the new directory
or
- ▶ Create files with the same names in the new directory

i The file names must be as specified in the table. Graphics must be of the same file type and size as the template.

- ▶ Customize file contents
- ▶ Save the changes
- ▶ The Adjusting and Testing Software will enter the file contents into every log.

7

**Connecting the
encoder**

7.1 Overview

This chapter describes how you can connect an encoder in the Adjusting and Testing Software. The procedure depends on the operating mode of the testing device.



Be sure to have read and understood the PWM Operating Instructions before connecting the encoder in the ATS.

Further information: "Opening documentation", Page 47



For detailed information on the required adapter cables and signal adapters, refer to the "User's Manual Cables and Connection Technology PWM 20 and PWM 21 (IK 215) Testing Package".

Further information: "Opening documentation", Page 47

Selecting the operating mode

The operating mode is selected in the **Operating mode of the testing device** dialog:

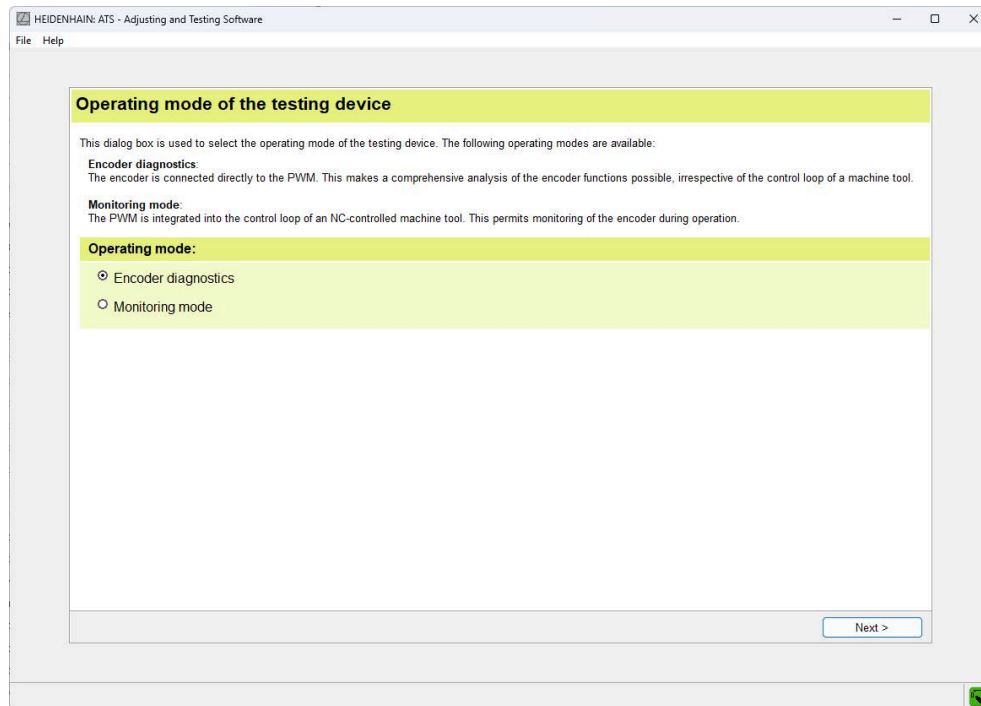

Configuration of the encoder parameters in the connection dialog

To connect the Adjusting and Testing Software to an encoder, information on the interface type and supply voltage is required. The following options are available to configure the parameters:

■ Connection via encoder ID:

If you enter the encoder ID in the connection dialog, the interface type and supply voltage are automatically taken from the encoder database

■ Manual connection:

If you do not know the encoder ID, or if the encoder database does not yet comprise the encoder, you can select the interface type and power supply manually



Some functions of the Adjusting and Testing Software are only available if you connect the encoder through its encoder ID (recommended procedure).



Perform regular software updates to keep the encoder database up to date.
Further information: "Updating software and encoder database", Page 40

Encoder ID

The ID you have to enter in the connection dialog depends on the encoder type.

- With exposed or multi-section encoders: the ID of the scanning head
- With sealed linear encoders: the ID of the scale housing

The ID is printed on the ID label.

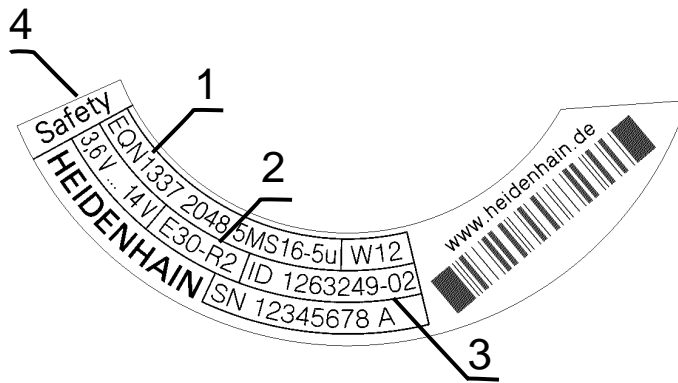

Figure 13: ID label

- 1 Encoder designation
- 2 Ordering designation/interface type of the encoder
- 3 Encoder ID
- 4 Indication that the encoder supports functional safety

i For modular rotary encoders integrated in HEIDENHAIN motors, you may enter the ID of the motor. The Adjusting and Testing Software will automatically determine the parameters of the modular rotary encoder.

i If the encoder and the testing device are connected via a separate signal converter, the procedure depends on the output signal of the signal converter.

- With TTL output signals: Connect the encoder and select the parameters manually
- With serial output signals: Enter the ID of the signal converter

After you have entered the ID of the signal converter, a further input form may appear containing the **Monitoring Identifier** field. The monitoring identifier can be found in the encoder mounting instructions.

The Adjusting and Testing Software uses the monitoring identifier to determine the parameters that are required for the correct interpretation of the position format in the Encoder Diagnostics mode.

i With touch probes connected to the PWM via a transceiver (SE), additional steps are required.

Further information: "Connecting touch probes", Page 80

7.2 Connection in the Encoder Diagnostics operating mode

NOTICE

Damage to the product from the engaging and disengaging of connecting elements during operation!

If you engage or disengage any connecting elements during operation, internal components of the devices may be damaged.

Before engaging or disengaging any connectors:

- ▶ Disconnect the encoder in the Adjusting and Testing Software
- ▶ Switch off the testing device, the subsequent electronics and the peripherals



When you connect the encoder in the Adjusting and Testing Software, you also activate power supply by the PWM. Comply with the safety precautions in the Adjusting and Testing Software and in the mounting instructions.

Precondition:

- The PWM is connected according to the operating mode
Further information: "Operating modes of the testing device", Page 26
- The PWM is switched on

7.2.1 Connection with encoder ID



- ▶ Double-click **Connect encoder** in the function menu
- The Adjusting and Testing Software shows the **Operating mode of the testing device** dialog.
- ▶ Select the **Encoder Diagnostics** mode
- ▶ Click **Next**
- The Adjusting and Testing Software shows the **Encoder selection** dialog.

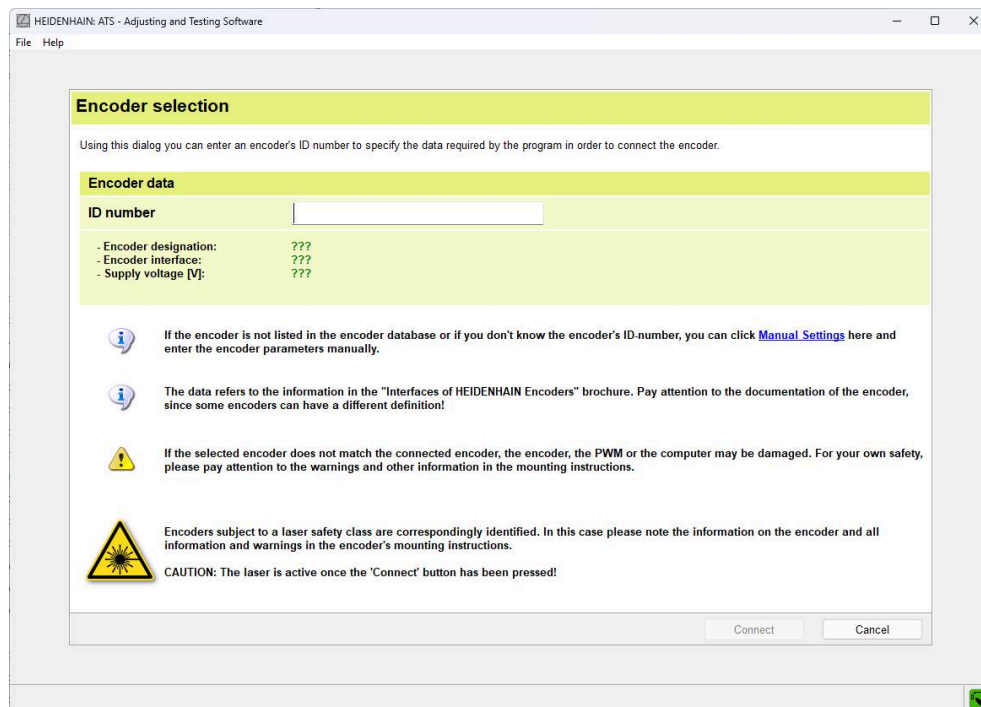

Figure 14: **Encoder selection** dialog

- ▶ Enter the encoder ID in the **ID-number** field; the entry may be with or without a hyphen
- The determined encoder parameters are shown in the **Encoder data** field.
- ▶ Click **Connect**
- The connection to the encoder is established.
- The voltage symbol in the information bar indicates that the encoder is powered by the PWM.
- The function menu shows the available functions (depending on the encoder).



When you connect the encoder by entering the encoder ID, the Adjusting and Testing Software automatically activates voltage readjustment.



If read protection is set for a range in the electronic ID label of an encoder with an EnDat 3 interface type, an error will occur when data is read out. The encoder cannot be operated in the software. A corresponding message will appear.

7.2.2 Manual connection



- ▶ Double-click **Connect encoder** in the function menu
- The Adjusting and Testing Software shows the **Operating mode of the testing device** dialog.
- ▶ Select the **Encoder Diagnostics** mode
- ▶ Click **Next**
- The Adjusting and Testing Software shows the **Encoder selection** dialog.

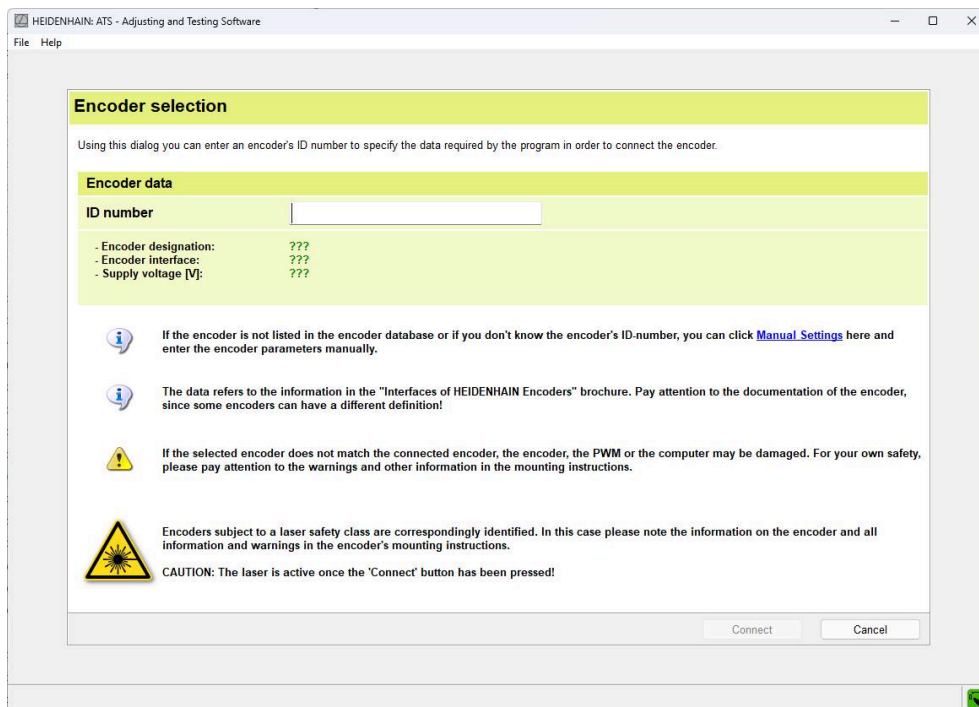

Figure 15: **Encoder selection** dialog

- ▶ Click **Manual Settings**
- The Adjusting and Testing Software displays safety precautions.
- ▶ Click **Next**
- The Adjusting and Testing Software displays the encoder parameters that can be selected.

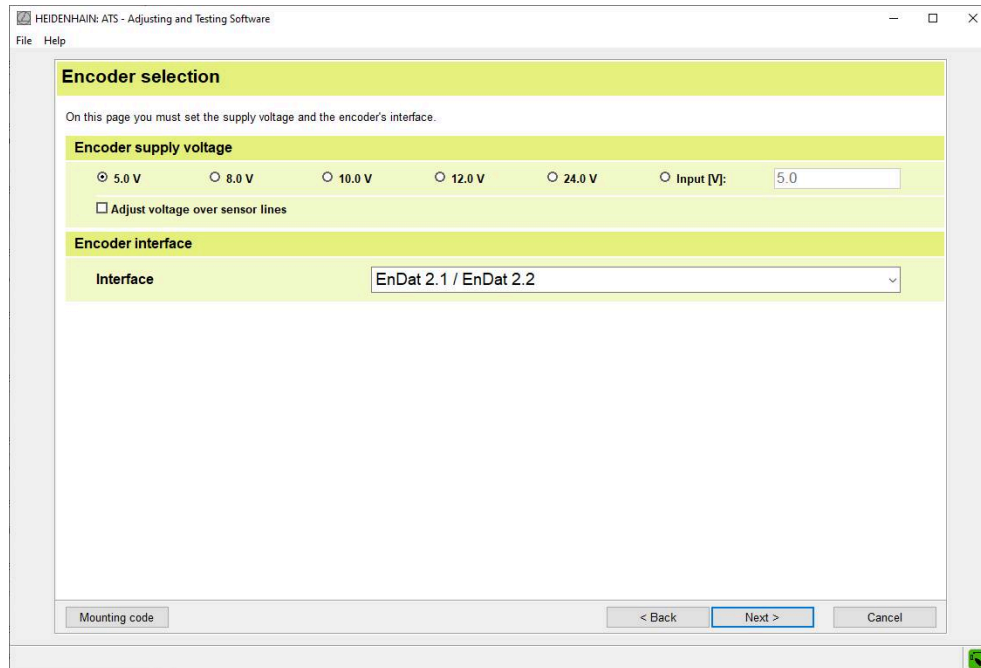

Figure 16: **Encoder selection** dialog for manual selection of the encoder parameters

- ▶ To activate voltage readjustment by the PWM, select the **Adjust voltage over sensor lines** checkbox.
This setting is recommended for all encoders, with the exception of touch probes.
- ▶ Select the permissible encoder supply voltage in the **Encoder supply voltage** section
- ▶ Select the interface type in the **Encoder interface** section
- ▶ Click **Next**
- ▶ The Adjusting and Testing Software displays safety precautions.
- ▶ Click **Connect**
- ▶ The connection to the encoder is established.
- ▶ The voltage symbol in the information bar indicates that the encoder is powered by the PWM.
- ▶ The function menu shows the available functions (depending on the encoder).



7.2.3 Connecting in bus operation

When you connect to a bus chain, the Adjusting and Testing Software automatically detects the participants (bus node). For this purpose, the Adjusting and Testing Software performs a bus check and automatically assigns a new bus address for each participant. The encoder at the end of the chain is assigned the address "1". All other participants are assigned numbers in ascending order. The encoder that is directly connected to the testing device is assigned the address with the highest number.



Bus check and automatic address assignment may take a few seconds.

Connection with encoder ID



- ▶ Double-click **Connect encoder** in the function menu
- The Adjusting and Testing Software shows the **Operating mode of the testing device** dialog.
- ▶ Select the **Encoder Diagnostics** mode
- ▶ Click **Next**
- The Adjusting and Testing Software shows the **Encoder selection** dialog.

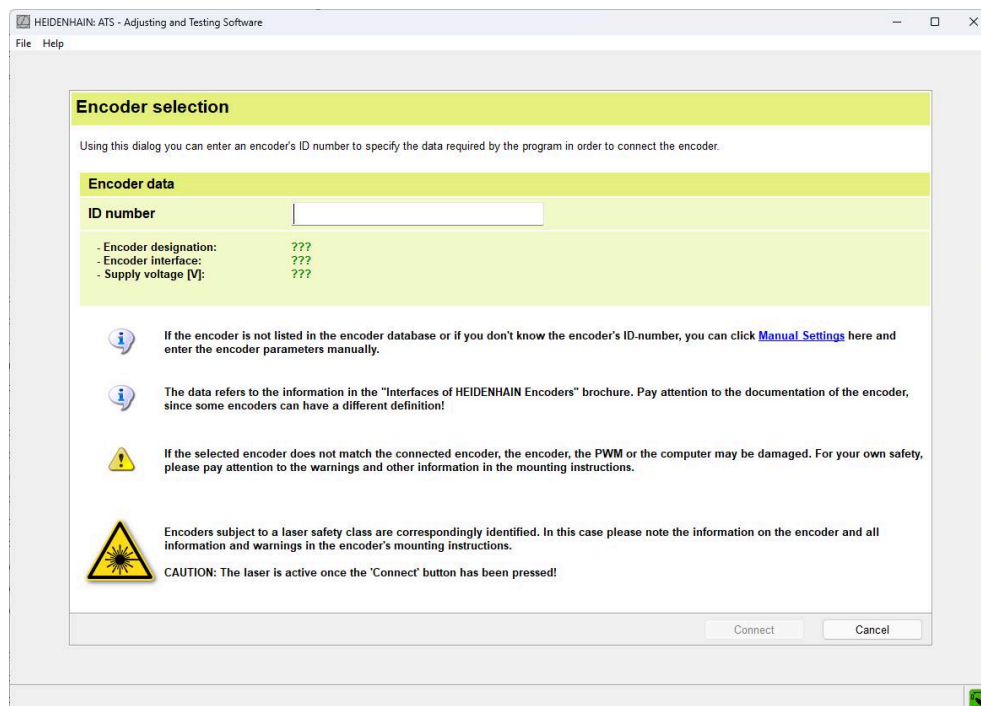

Figure 17: **Encoder selection** dialog

- ▶ Enter the encoder ID of the encoder located at the end of the bus chain in the **ID number** field; the entry may be with or without a hyphen
- The determined encoder parameters are shown in the **Encoder data** field.
- ▶ Click **Connect**
- The bus is being checked.
- Automatic address assignment is performed.
- The connection to the bus chain is set up.
- The voltage symbol in the information bar indicates that the bus chain is powered by the PWM.
- An overview of the detected bus participants is displayed.



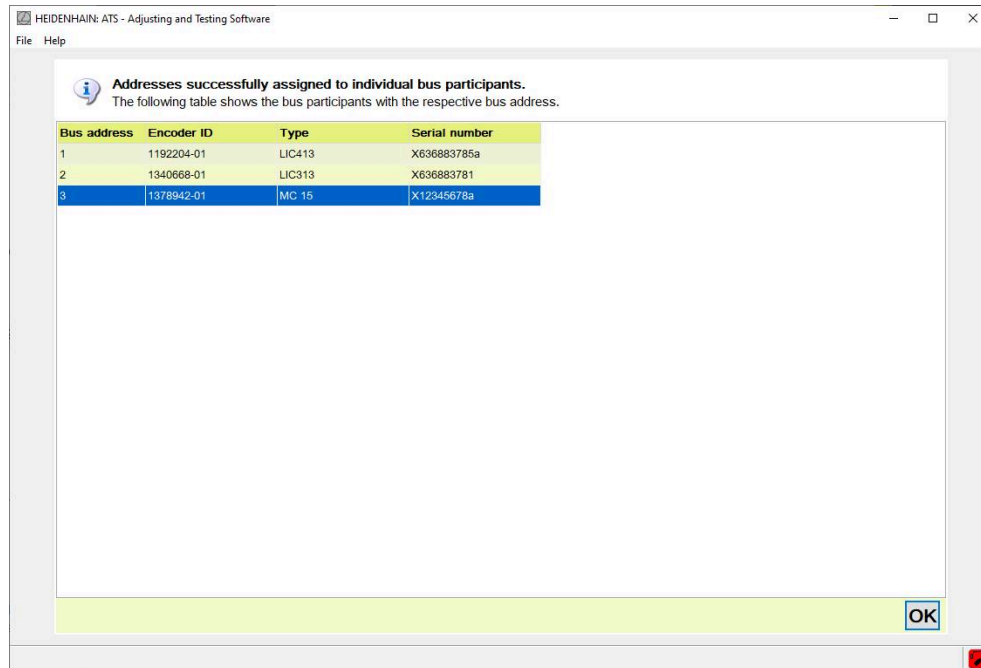

Figure 18: Overview of bus participants after successful connection

- ▶ Confirm with **OK**
- > The function menu shows the available functions (depending on the encoder).

Manual connection



- ▶ Double-click **Connect encoder** in the function menu
- The Adjusting and Testing Software shows the **Operating mode of the testing device** dialog.
- ▶ Select the **Encoder Diagnostics** mode
- ▶ Click **Next**
- The Adjusting and Testing Software shows the **Encoder selection** dialog.

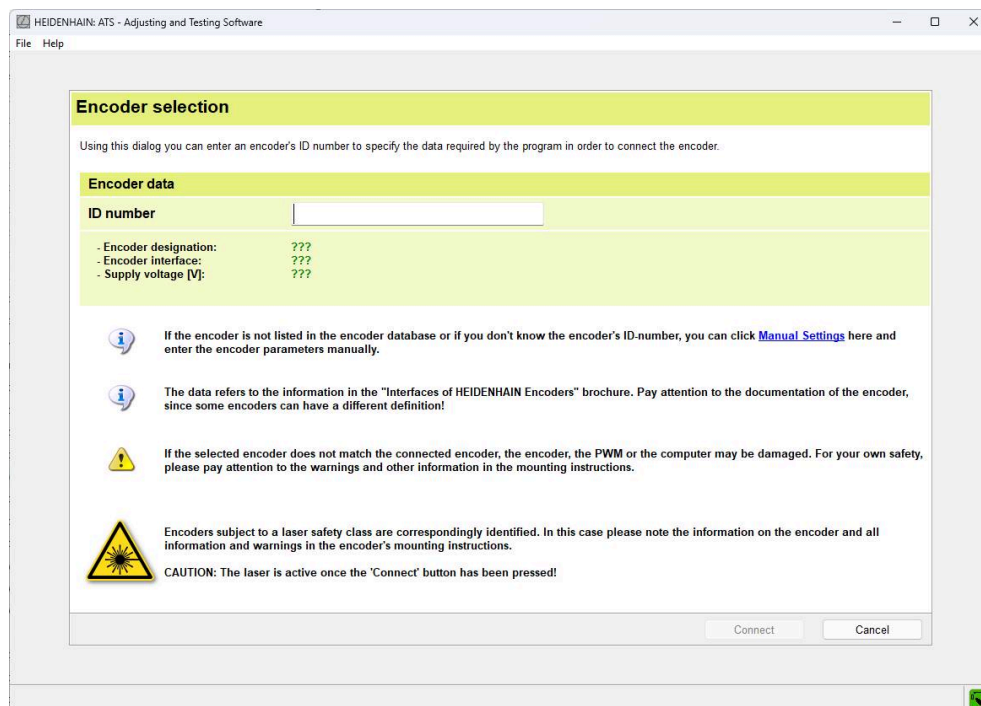

Figure 19: **Encoder selection** dialog

- ▶ Click **Manual Settings**
- The Adjusting and Testing Software displays safety precautions.
- ▶ Click **Next**
- The Adjusting and Testing Software displays the encoder parameters that can be selected.

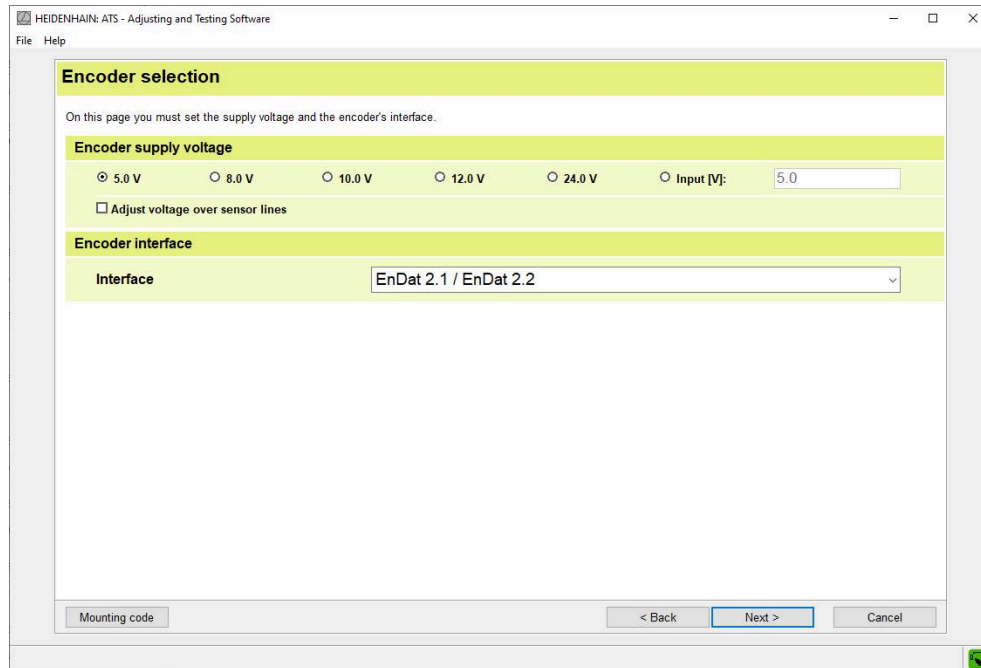

Figure 20: **Encoder selection** dialog for manual selection of the encoder parameters

- ▶ In the **Encoder supply voltage** section, select a value close to the maximum permissible supply voltage of the connected encoders (recommendation: 12 V)
- ▶ Select the interface type "EnDat 3 (E30-R4,E30-RM,E30-RB)" in the **Encoder interface** section
- ▶ Click **Next**
- The Adjusting and Testing Software displays safety precautions.
- ▶ Click **Connect**
- The bus is being checked.
- Automatic address assignment is performed.
- The connection to the bus chain is set up.
- The voltage symbol in the information bar indicates that the bus chain is powered by the PWM.
- An overview of the detected bus participants is displayed.



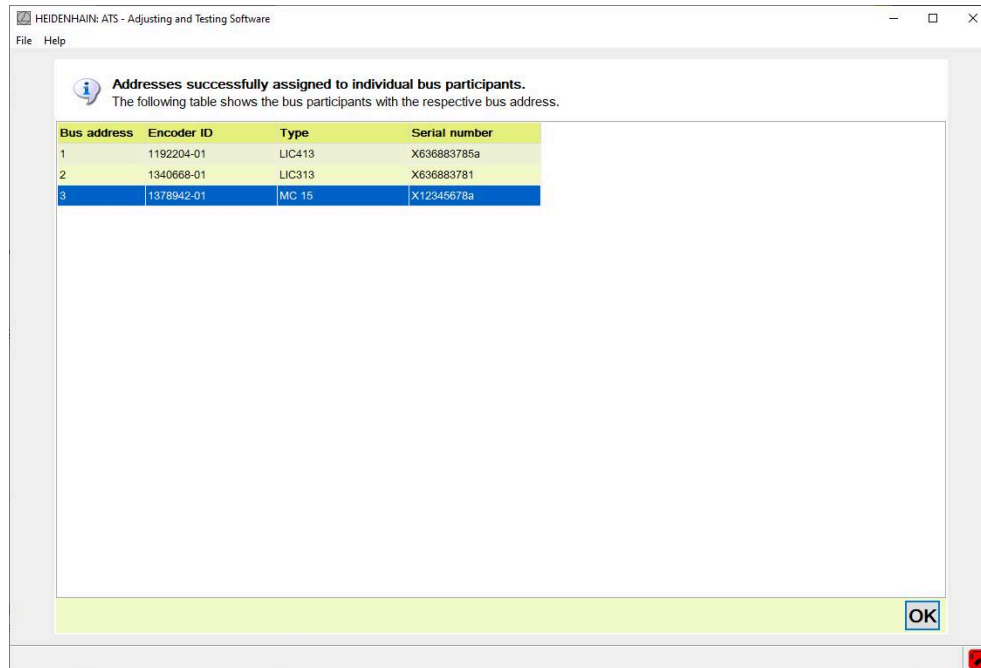

Figure 21: Overview of bus participants after successful connection

- The function menu shows the available functions (depending on the encoder).

7.3 Connecting in Monitoring mode

WARNING

Danger due to uncontrolled axis movements upon start of monitoring mode!

Integrating the PWM into the control loop of the machine tool influences the power supply of the encoder and the grounding conditions. Uncontrolled axis motions may occur when the monitoring mode is started. This may result in death or serious personal injury.

Before starting the monitoring mode:

- ▶ Note the safety precautions in the Operating Instructions
- ▶ Leave the traverse range of the machine tool
- ▶ Move the machine axes to the middle of the traverse range
- ▶ Secure machine axes against falling down
- ▶ Have one person at the emergency stop button so that this person can switch off the machine immediately in case of hazard

After having started the monitoring mode:

- ▶ Check whether the machine axis can be traversed in a controlled manner

WARNING

Danger due to uncontrolled axis movements when engaging and disengaging connecting elements!

If you engage or disengage any connecting elements in the monitoring mode, uncontrolled axis movements may occur. This may result in death or serious personal injury.

Before engaging or disengaging any connectors:

- ▶ Observe the manufacturer's documentation of the subsequent electronics, the peripherals and the machine tool
- ▶ Secure the machine axes against uncontrolled movements
- ▶ Disconnect the encoder in the Adjusting and Testing Software
- ▶ Switch off the testing device, the subsequent electronics and the peripherals

NOTICE

Damage to the product caused by overvoltage!

If you select incorrect encoder parameters in the Adjusting and Testing Software, the encoder, the testing device, and the peripheral devices may be damaged.

- ▶ Connect via encoder ID and retrieve the encoder parameters from the encoder database
- ▶ For manual connection, observe the information provided by the encoder manufacturer

NOTICE

Damage to the product from the engaging and disengaging of connecting elements during operation!

If you engage or disengage any connecting elements during operation, internal components of the devices may be damaged.

Before engaging or disengaging any connectors:

- ▶ Disconnect the encoder in the Adjusting and Testing Software
- ▶ Switch off the testing device, the subsequent electronics and the peripherals

Precondition:

- The subsequent electronics is switched off
- The PWM is connected according to the operating mode
Further information: "Operating modes of the testing device", Page 26
- The PWM is switched on

7.3.1 Connection with encoder ID

⚠ WARNING

Damage to the signal adapter by overvoltage!

The SA 100 and SA 110 signal adapters are designed for a supply voltage of 5.5 V maximum. If the encoder requires a higher supply voltage, the signal adapter may be damaged if you establish the connection through the encoder ID. As a consequence, the encoder, the PWM and the downstream electronics may be damaged.

- ▶ Observe the encoder supply voltage displayed in the connection dialog
- ▶ Abort the procedure, if the supply voltage of the encoder exceeds 5.5 V
- ▶ Use a suitable signal adapter, e.g. SA 2380



- ▶ Double-click **Connect encoder** in the function menu
- > The Adjusting and Testing Software shows the **Operating mode of the testing device** dialog.
- ▶ Select **Monitoring** mode
- ▶ Click **Next**
- > The Adjusting and Testing Software shows the **Monitoring adapter** dialog.



Figure 22: **Monitoring adapter** dialog in Monitoring mode

- ▶ Select the desired adapter
- ▶ Click **Next**
- The Adjusting and Testing Software shows the **Encoder selection** dialog.

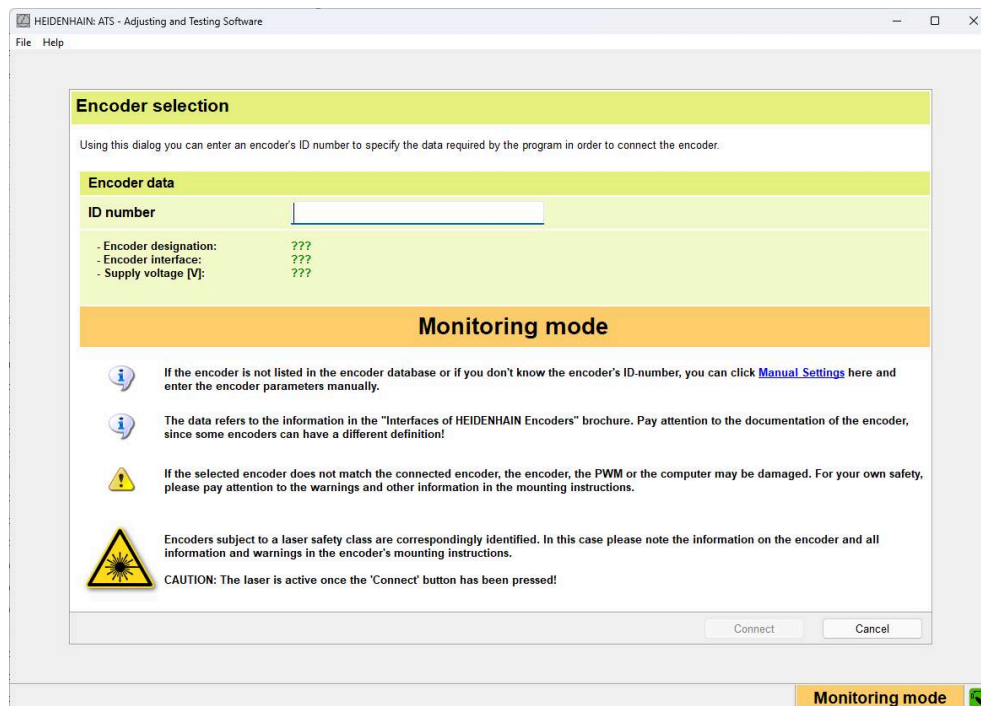

Figure 23: **Encoder selection** dialog in Monitoring mode

- ▶ Enter the encoder ID in the **ID number** field. The entry may be with or without a hyphen.
- The determined encoder parameters are shown in the **Encoder data** field.
- ▶ Click **Connect**
- The connection to the encoder is established.



- > The voltage symbol in the information bar indicates that the signal adapter is powered by the PWM.
- > The function menu shows the available functions (depending on the encoder).
 - ▶ Switch on the downstream electronics
- > The encoder is powered by the downstream electronics.

7.3.2 Manual connection

WARNING

Damage to the signal adapter by overvoltage!

The SA 100 and SA 110 signal adapters are designed for a supply voltage of 5.5 V maximum. If the encoder requires a higher supply voltage, the signal adapter may be damaged if you establish the connection through the encoder ID. As a consequence, the encoder, the PWM and the downstream electronics may be damaged.

- ▶ Observe the encoder supply voltage displayed in the connection dialog
- ▶ Abort the procedure, if the supply voltage of the encoder exceeds 5.5 V
- ▶ Use a suitable signal adapter, e.g. SA 2380



If you connect the encoder manually, the monitoring mode is only possible for incremental encoders.

With encoders with a serial interface, you can retrieve the encoder ID from the encoder memory: If you connect the encoder manually in the Encoder diagnostics mode, the Adjusting and Testing Software displays the encoder ID in the information bar.

Further information: "Connection in the Encoder Diagnostics operating mode", Page 63



- ▶ Double-click **Connect encoder** in the function menu
- > The Adjusting and Testing Software shows the **Operating mode of the testing device** dialog.
- ▶ Select **Monitoring** mode
- ▶ Click **Next**
- > The Adjusting and Testing Software shows the **Monitoring adapter** dialog.

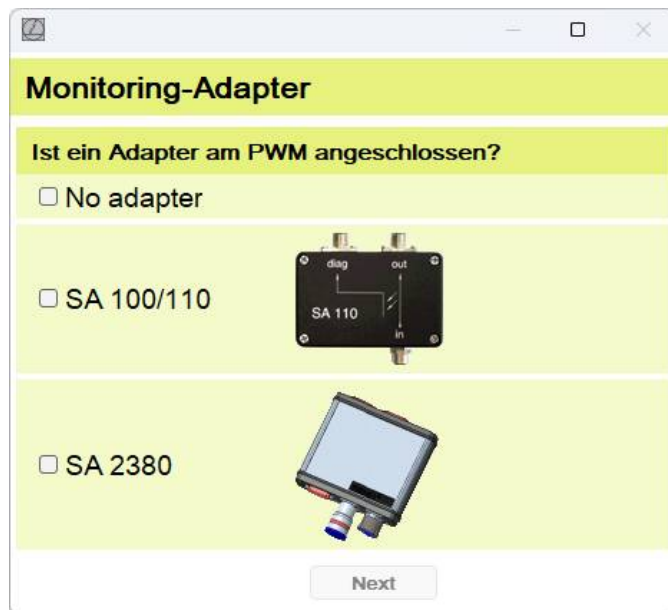

Figure 24: **Monitoring adapter** dialog in Monitoring mode

- ▶ Select the desired adapter
- ▶ Click **Next**
- The Adjusting and Testing Software shows the **Encoder selection** dialog.
- ▶ Enter the encoder ID in the **ID number** field. The entry may be with or without a hyphen.
- The determined encoder parameters are shown in the **Encoder data** field.
- ▶ Click **Connect**
- The connection to the encoder is established.



- The voltage symbol in the information bar indicates that the signal adapter is powered by the PWM.
- The function menu shows the available functions (depending on the encoder).
- ▶ Switch on the downstream electronics
- The encoder is powered by the downstream electronics.

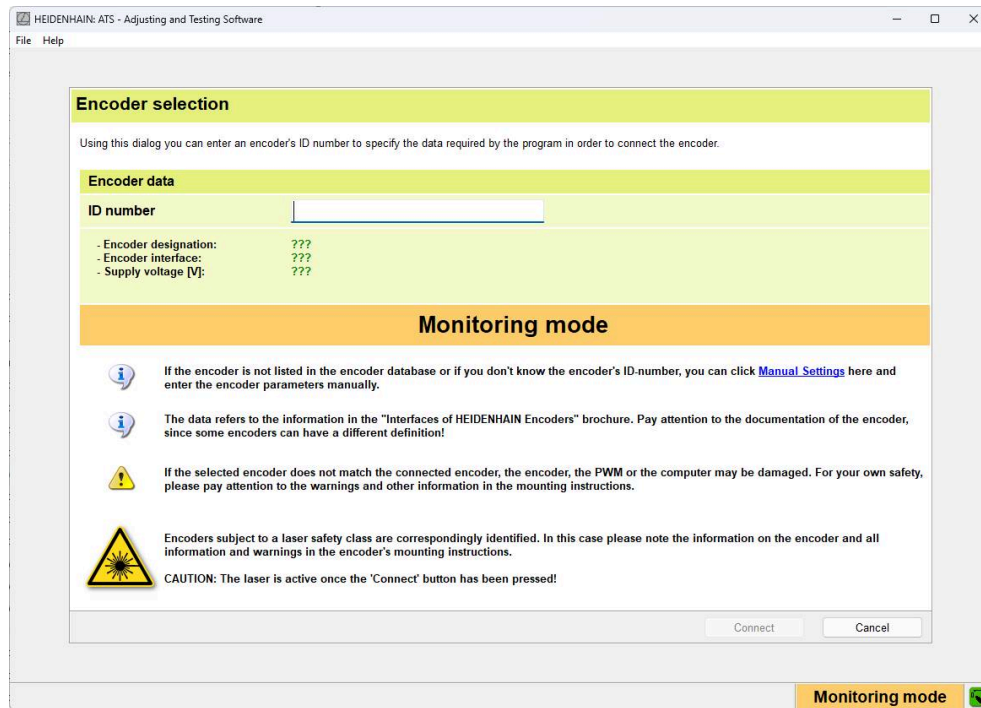

Figure 25: **Encoder selection** dialog in Monitoring mode

- ▶ Click **Manual Settings**
- The Adjusting and Testing Software displays safety precautions.
- ▶ Click **Next**
- The Adjusting and Testing Software displays the encoder parameters that can be selected.

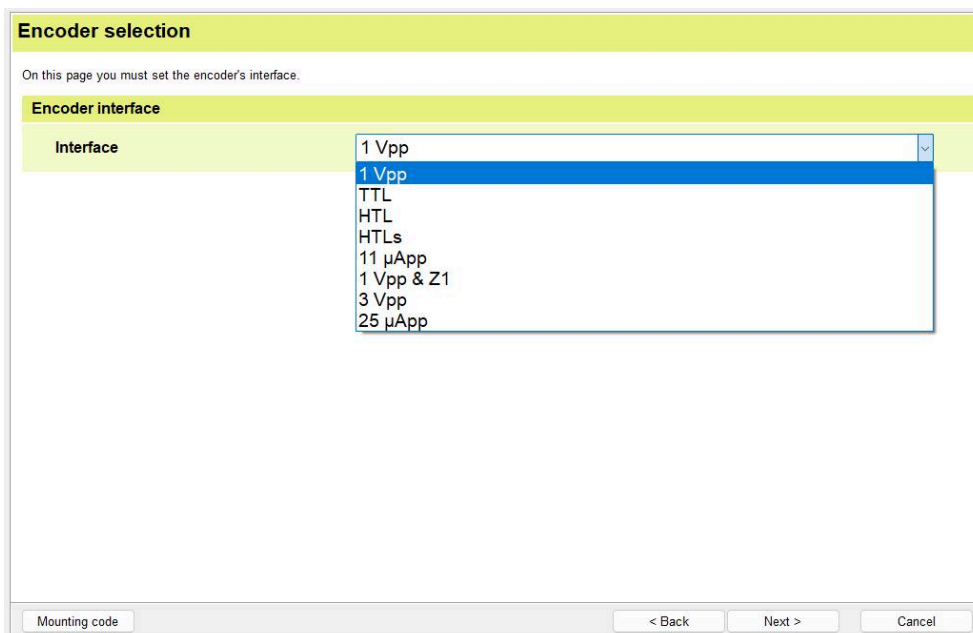

Figure 26: **Encoder selection** dialog for manual selection of the encoder parameters

- ▶ Select the interface type in the **Encoder interface** section
- ▶ Switch on the downstream electronics
- > The encoder is powered by the downstream electronics.
- ▶ Click **Next**
- > The Adjusting and Testing Software displays safety precautions.
- ▶ Click **Connect**
- > The connection to the encoder is established.
- > The voltage symbol in the information bar indicates that the signal adapter is powered by the PWM.
- > The function menu shows the available functions (depending on the encoder).



7.4 Disconnecting the encoder



When you disconnect the encoder, the voltage supply by the PWM is deactivated as well.



- ▶ Double-click **Disconnect encoder** in the function menu
- > The Adjusting and Testing Software separates the connection to the encoder.



- > The voltage symbol in the information bar indicates that the PWM does not output any voltage.
- > The Adjusting and Testing Software displays the opening screen.

7.5 Connecting touch probes

The following steps are required in the Adjusting and Testing Software to connect a touch probe:

- Connect the transceiver unit (SE)
- Establish radio communication between the SE and the touch probe, either by pairing or by reading in the electronic ID label

NOTICE

Damage to the product from the engaging and disengaging of connecting elements during operation!

If you engage or disengage any connecting elements during operation, internal components of the devices may be damaged.

Before engaging or disengaging any connectors:

- ▶ Disconnect the encoder in the Adjusting and Testing Software
- ▶ Switch off the testing device, the subsequent electronics and the peripherals



When you establish the connection to the transceiver unit in the Adjusting and Testing Software, you also activate the power supply by the PWM.

Precondition:

- The PWM is connected according to the operating mode
Further information: "Operating modes of the testing device", Page 26
- The PWM is switched on

Connecting the transceiver unit (SE)



- ▶ To establish the connection to the SE, double-click **Connect encoder** in the function menu
- The Adjusting and Testing Software shows the **Operating mode of the testing device** dialog.
- ▶ Select the **Encoder Diagnostics** mode
- ▶ Click **Next**
- The Adjusting and Testing Software shows the **Encoder selection** dialog.

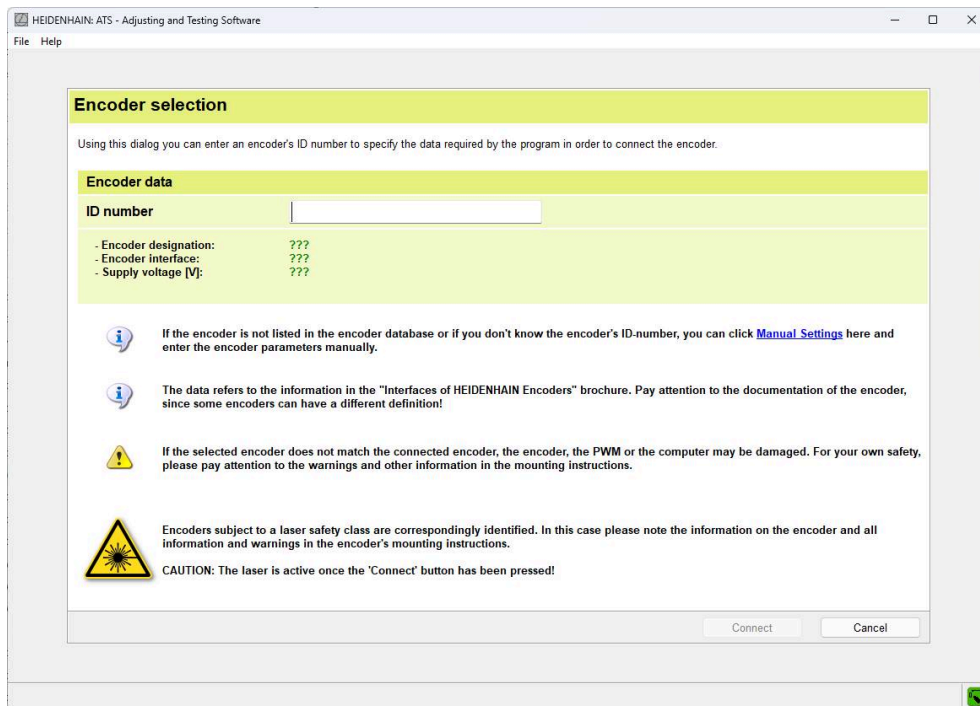

Figure 27: **Encoder selection** dialog

- ▶ Enter the ID of the SE in the **ID number** field. The entry may be with or without a hyphen.
- The determined parameters are shown in the **Encoder data** field.
- ▶ Click **Connect**
- The connection to the SE is set up.
- The voltage symbol in the information bar indicates that the SE is powered by the PWM.
- The function menu shows the available functions (depending on the encoder).



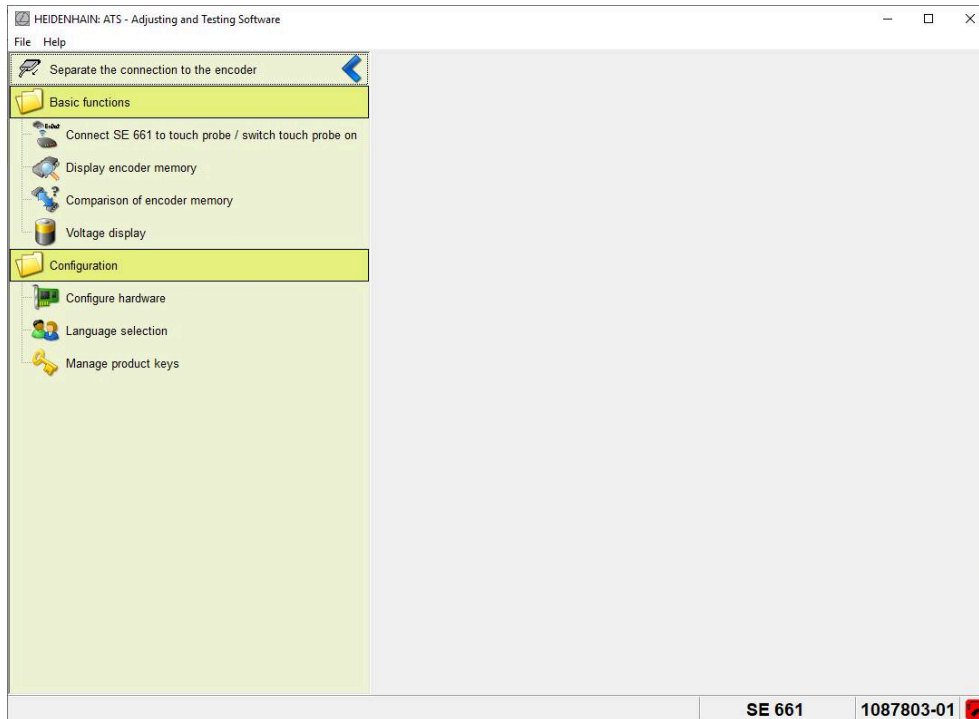

Figure 28: Function menu after connecting the transceiver unit



As an alternative, you can connect the SE manually. The procedure is the same as for manually connecting an encoder in the Encoder diagnostics mode.

Further information: "Manual connection", Page 65

Establishing radio communication by pairing



Observe the mounting instructions of the touch probe before pairing the touch probe.



- ▶ To establish the radio communication between the SE and the touch probe, double-click **Connect SE 661 to touch probe / switch touch probe on** in the function menu
- ▶ When you establish the radio communication for the first time, select the option **Pair touch probe** in the dialog box
- ▶ Click **OK**
- ▶ Follow the instructions of the software wizard
- > The radio communication between the SE and the touch probe is established.
- > The Adjusting and Testing Software reads the electronic ID label of the touch probe.



You can save the electronic ID label to a file and use it for reconnecting later on.

- ▶ Click **Save** in the dialog box to save the ID label to a file
- ▶ Select the desired storage location in the dialog
- ▶ Enter the file name
- ▶ Click **Save**
- > The file is saved.
- ▶ Click **Next**
- > The Adjusting and Testing Software shows the data of the connected touch probe.
- ▶ Click **Exit**
- > The function menu shows the available functions (depending on the encoder).

Establishing the radio communication by reading the electronic ID label

If you have saved the electronic ID label to a file when pairing the touch probe, you can now use this file for reconnecting.



- ▶ To establish the radio communication between the SE and the touch probe, double-click **Connect SE 661 to touch probe / switch touch probe on** in the function menu
- ▶ Select the option **Connect the touch probe using the saved file** in the dialog
- ▶ Click **Load file**
- ▶ Select the storage location for the file in the dialog
- ▶ Click **Open**
- > The Adjusting and Testing Software displays the data loaded from the file.
- ▶ Click **Next**
- > The Adjusting and Testing Software shows the data of the connected touch probe.
- ▶ Click **Exit**
- > The function menu shows the available functions (depending on the encoder).

7.6 Disconnecting the touch probe

The following steps are required in the Adjusting and Testing Software to disconnect a touch probe:

- Disconnect the radio communication between the touch probe and the SE transceiver unit
- Disconnect the connection between the PWM and the SE transceiver unit



When you separate the connection between the PWM and the SE transceiver unit, the voltage supply by the PWM is deactivated as well.

Disconnecting radio communication



- ▶ Double-click **Switch off touch probe** in the function menu
- ▶ Click **Switch off** in the dialog
- > The radio communication is terminated.
- > The touch probe is in standby mode.

Separating the connection to the SE transceiver unit



- ▶ Double-click **Disconnect encoder** in the function menu
- > The Adjusting and Testing Software separates the connection to SE.



- > The voltage symbol in the information bar indicates that the PWM does not output any voltage.
- > The Adjusting and Testing Software displays the opening screen.

8

**Encoder mounting
(mounting wizard)**

8.1 Encoder mounting with mounting wizard

The Adjusting and Testing Software features special adjustment functions—referred to as mounting wizards/mounting assistants—for mounting certain encoders. In general, these are exposed encoders the scanning heads of which must be exactly aligned.

The **Mounting wizard** function is shown in the function menu after you have connected the encoder through the encoder ID. When you call this function, the mounting wizard will guide you through the required steps.

Depending on the encoder, further functions may be available, for example:

- **Tension tape** for replacing steel scale tapes
- **Encoder settings** for adapting certain encoder settings
- **Report function**



For more information on encoder mounting or encoder-specific functions such as **Tension tape** or **Encoder settings** refer to the documentation of the encoder.



If the encoder is not in the encoder database, you can connect it using an ATS code.

Further information: "Connecting with ATS code or communication code", Page 87

Connecting with ATS code or communication code

If a mounting wizard is required for correct encoder mounting, you may need to connect the encoder using an "ATS code" or "communication code" (depending on the encoder). Only then will the associated mounting wizard appear in the Adjusting and Testing Software. The ATS code or communication code is available on request.



For more information, refer to the supplied documentation on encoder mounting.

Proceed as follows to connect the encoder using an ATS code or communication code:



- ▶ Double-click **Connect encoder** in the function menu
- The Adjusting and Testing Software shows the **Encoder selection** dialog.

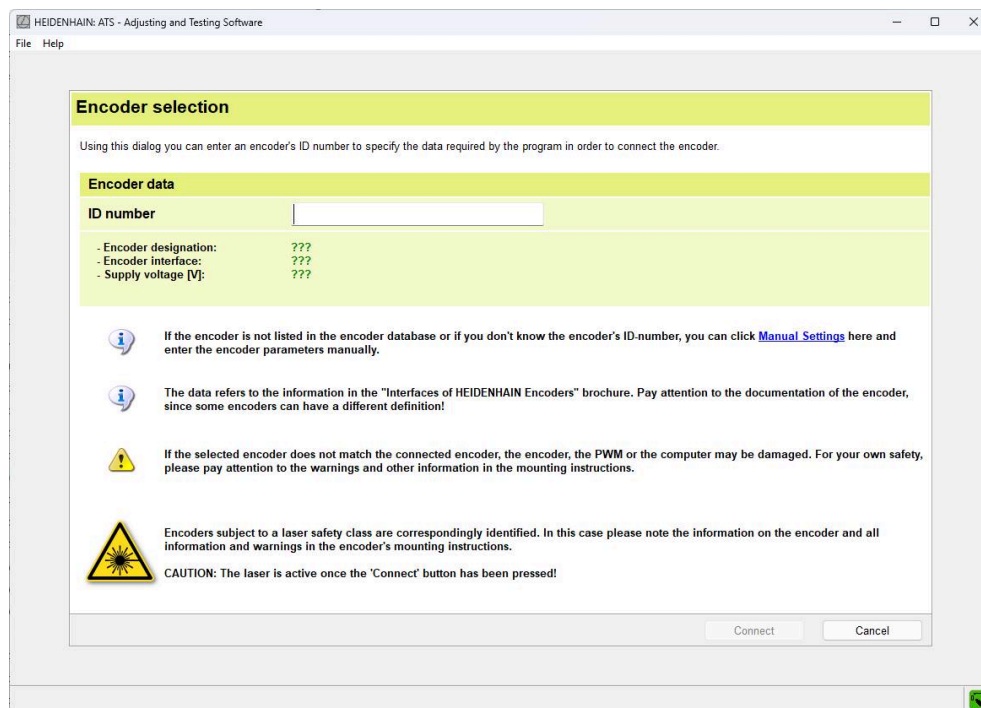

Figure 29: **Encoder selection** dialog

- ▶ Click **Manual Settings**
- The Adjusting and Testing Software displays safety precautions.
- ▶ Click **Next**
- The Adjusting and Testing Software displays the encoder parameters that can be selected.

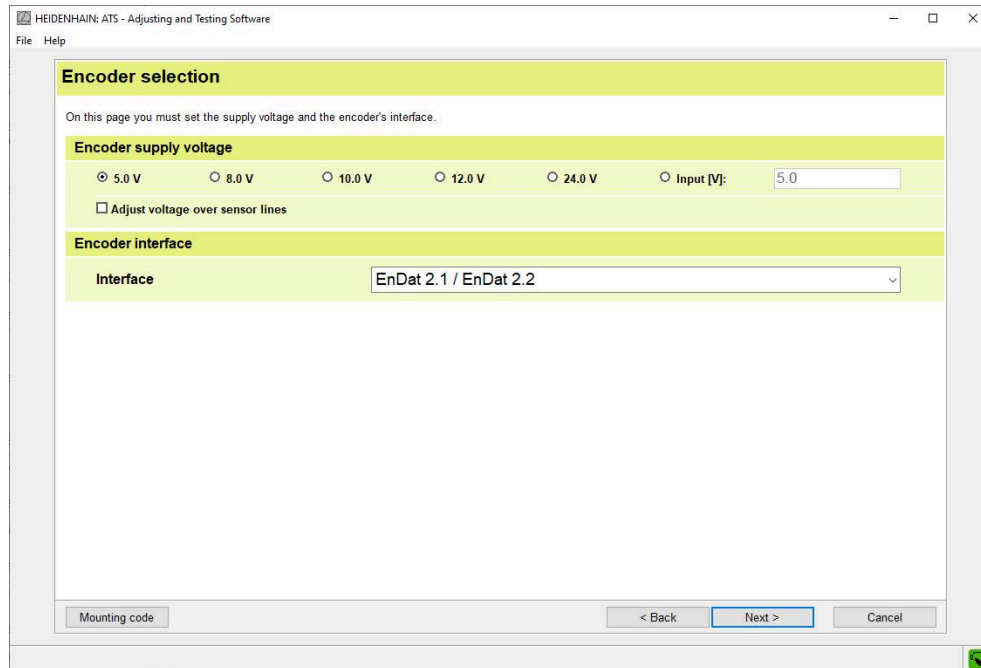

Figure 30: **Encoder selection** dialog for manual selection of the encoder parameters

- ▶ To activate voltage readjustment by the PWM, check the box **Adjust voltage over sensor lines** (recommended)
- ▶ Select the permissible encoder supply voltage in the **Encoder supply voltage** section
- ▶ Select the interface type in the **Encoder interface** section
- ▶ Click **Mounting code**
- ▶ The **ATS/Communication code** field is displayed.

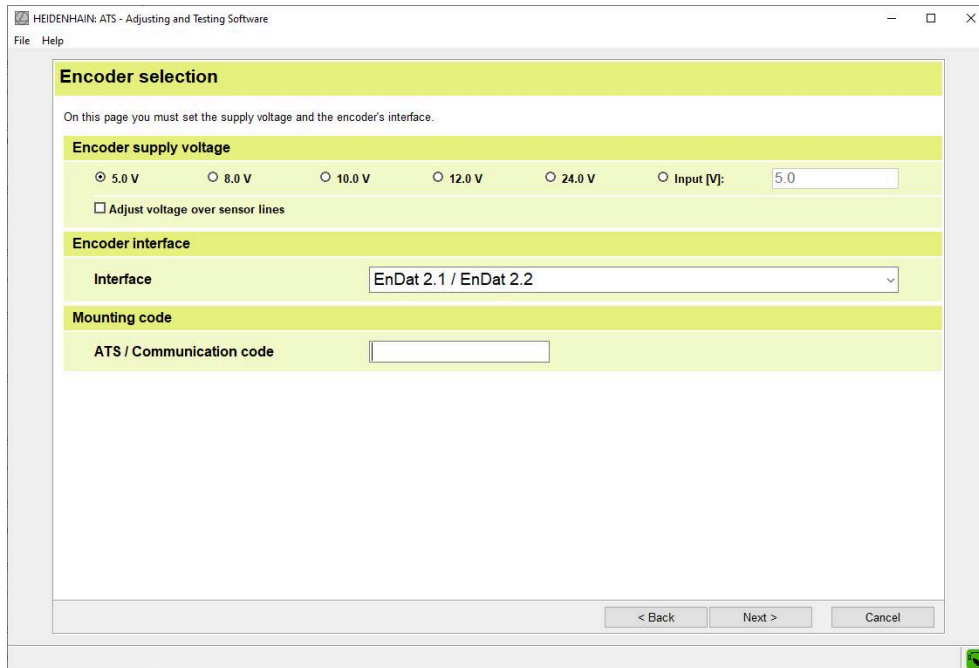

Figure 31: **Encoder selection** dialog box with **ATS/Communication code** field

- ▶ Enter the ATS or communication code
- ▶ Click **Next**
- The Adjusting and Testing Software displays safety precautions.
- ▶ Click **Connect**
- The connection to the encoder is established.
- The voltage symbol in the information bar indicates that the encoder is powered by the PWM.
- The function menu shows the available functions (depending on the encoder).







9

**Inspecting encoders
with sinusoidal
incremental signals**

9.1 Overview

The Adjusting and Testing Software offers the following functions for inspecting encoders with sinusoidal output signals (e.g., 1 V_{PP} or 11 μA_{PP}):

Icon	Function	Description
	Incremental signal	Test functions for incremental signals, incl. tolerance check if required
	Recording	Functions for recording and analyzing the incremental signals
	Voltage display	Measured values of voltage and current supply
	Encoder information	Display of encoder information

i The displays and the scope of functions of the Adjusting and Testing Software depend on the connected encoder and on the software configuration. When you establish the connection to the encoder, the function menu shows the available functions and operating elements.

i The views of the **Incremental signal** function have been revised regarding the display layout. Since the graphics have been changed only slightly and the functionality basically remains the same, the screenshots in the documentation will be updated only for significant changes.

9.2 Checking incremental signals

9.2.1 Incremental signal function

Depending on the connected encoder, the **Incremental signal** comprises the following views:

- **Analog**: Inspection of incremental signals, reference signal, and commutation signals
- **Counter**: Check of counting function and reference function
- **PWT**: Check of incremental signals using bar graphs
- **Homing – Limit**: Check of limit signals
- **Protocol**: Creation of logs
- **Note**: Display of notes on current measurement

 Some functions of the Adjusting and Testing Software are only available if you connect the encoder through its encoder ID (recommended procedure).

 The displayed tolerances are the HEIDENHAIN standard values (depending on the encoder).
Further information: "Units and tolerances", Page 36



- ▶ Double-click **Incremental signal** in the function menu to call the function
- > The Adjusting and Testing Software shows the **Analog** view.

9.2.2 Analog view

The **Analog** view allows you to examine the following signals:

- Incremental signals
- Reference signals
- Commutation signals

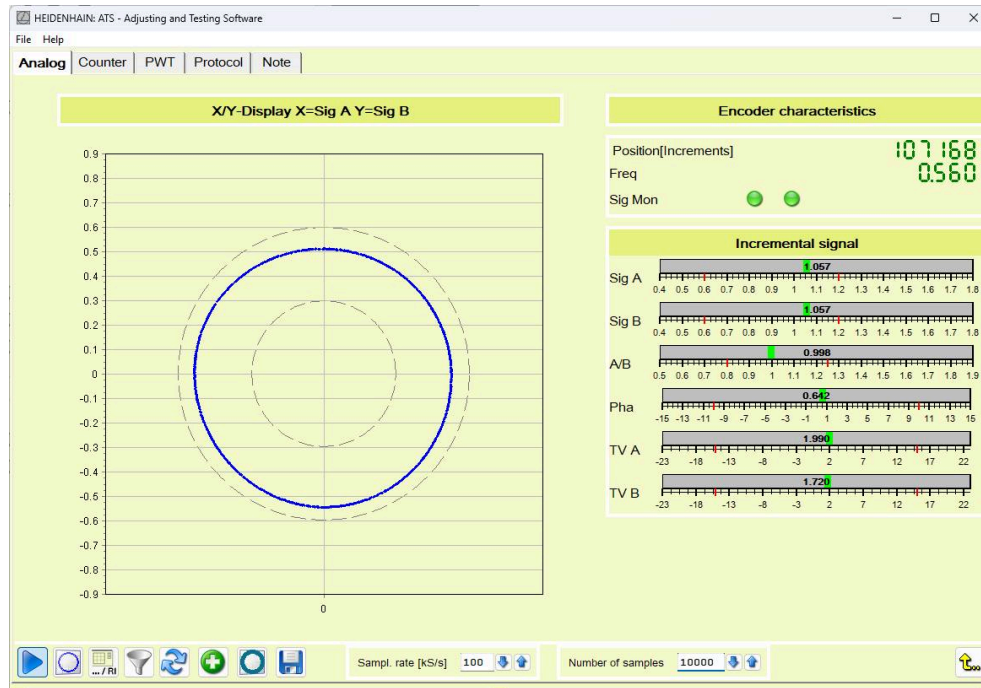

Figure 32: **Analog** screen of the **Incremental signal** function

For diagram display, you can toggle between X/Y graph and Y/t graph.

X/Y graph

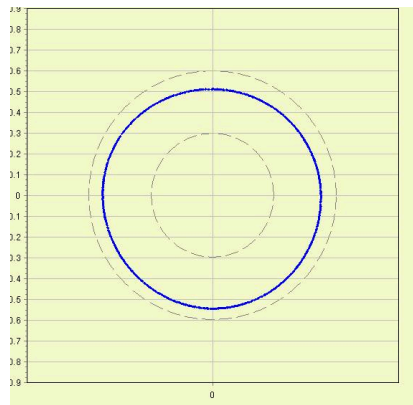

Figure 33: X/Y graph

Depiction	Description
X axis	Amplitude of signal A Unit: volts or microamperes (depending on the interface)
Y axis	Amplitude of signal B Unit: volts or microamperes (depending on the interface)
Outer and inner circle	Tolerance limits
Blue circle	Signal circle of signals A and B

Y/t graph

Figure 34: Y/t graph

Depiction	Description
X axis (t)	Number of samples
Y axis	Signal amplitude Unit: volts or microamperes (depending on the interface)
Red curve	Signal A
Blue curve	Signal B
Green curve	Reference signal
Dashed lines in the color of the signals	Tolerance limits of the respective signal

Encoder characteristics section

Display	Description
Position [increments]	Current count of the position display Unit: Increments
Freq	Input frequency Unit: kHz
Sig Mon	Status displays of signal monitoring <ul style="list-style-type: none"> ■ Green: The signal amplitudes are within the tolerance range ■ Red: The signal amplitudes exceed at least one tolerance limit <p>The left status display shows the current status. When a tolerance limit is exceeded, the status display turns red for about 5 seconds.</p> <p>The right status display shows the overall status of the measurement. When a tolerance limit is exceeded, the status display is permanently red.</p>

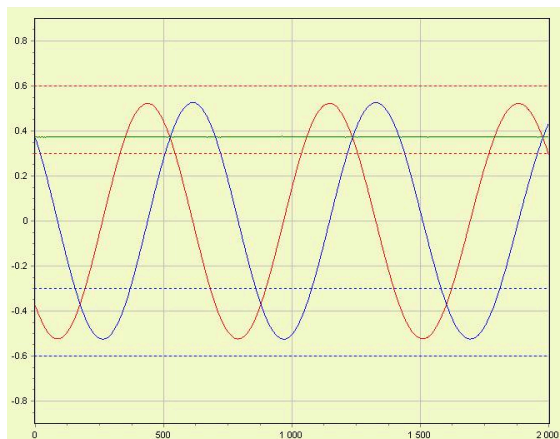
Incremental signal section

The bar graph shows the measured values and the results of the tolerance check.

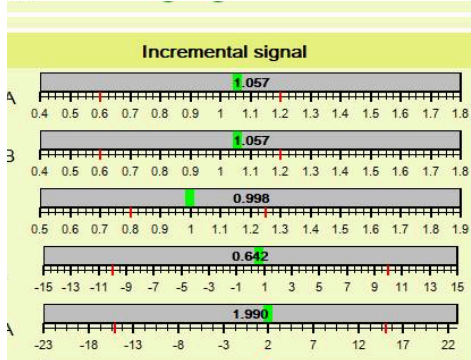

Measurement results are within tolerance limits

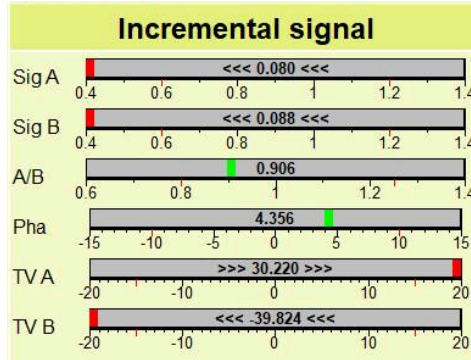

Several measurement results are outside the tolerance limits

Depiction	Description
	The indicator shows the measured value. The color of the indicator represents the result of the tolerance check: <ul style="list-style-type: none"> Green: Measured value within the tolerance range Red: Measured value outside the tolerance range
	The red marks indicate the tolerance limits.
<< >>	The arrows indicate that the measured value is beyond the scale. The direction of the arrow shows the direction where the measured value lies.





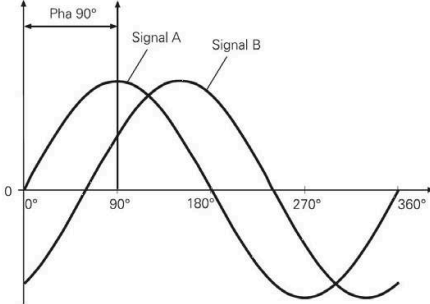



The following information refers to the signal diagrams in the document **Interfaces of HEIDENHAIN Encoders**.
Further information: "Opening documentation", Page 47

Display	Description
Sig A	Amplitude of signal A
Sig B	Amplitude of signal B
A / B	Signal ratio of signals A and Signal B Signal ratio = A / B Optimum condition: Signal ratio = 1

Display	Description
Pha	<p data-bbox="576 356 927 389">Phase shift of signals A and B</p> <p data-bbox="576 396 1166 461">Optimum condition: Signal A precedes signal B by 90°.</p>  <p data-bbox="576 846 778 880">Phase shift = 90°</p> <p data-bbox="576 887 826 920">Phase shift error = 0°</p> <p data-bbox="576 927 1203 1025">The Adjusting and Testing Software shows the phase shift error, i.e. the deviation from the optimum condition in degrees.</p> <p data-bbox="576 1032 951 1066">Calculation: Pha = φA + φB / 2</p>

Display	Description
TV A	<p data-bbox="576 360 874 389">On-to-off ratio of signal A</p> <p data-bbox="576 398 1195 555">The incremental signals are triggered at zero crossover and converted into square-wave signals. One signal period consists of the high time plus the low time of the square-wave signal and is subdivided into 360°.</p> <p data-bbox="576 564 1142 629">Optimum condition: High time and low time of a signal period have the same length.</p> <div data-bbox="576 658 1066 965" style="text-align: center;"> </div> <p data-bbox="576 1014 909 1046">High time = Low time = 180°</p> <p data-bbox="576 1055 826 1084">On-off ratio error = 0°</p> <p data-bbox="576 1093 1203 1189">The Adjusting and Testing Software shows the on-off ratio error, i.e. the deviation from the optimum condition in degrees.</p> <p data-bbox="576 1198 1182 1294">In the documentation, the ratio of high time and low time may also be specified as symmetry deviation (SYM) in radians.</p> <div data-bbox="576 1317 1211 1480" style="border: 1px solid black; padding: 5px; margin: 10px 0;"> <p data-bbox="592 1330 1190 1451"> i In contrast to the definition of the symmetry (SYM), the algebraic sign of the deviation is also output. This simplifies application cases, such as mounting an encoder. </p> </div> <p data-bbox="576 1503 718 1532">Calculation:</p> <p data-bbox="576 1541 823 1570">SYM = P - N / 2 · M</p> <p data-bbox="576 1579 943 1608">TV = 2 · 180 / π · sin (2 · SYM)</p>
TV B	<p data-bbox="576 1626 874 1655">On-to-off ratio of signal B</p> <p data-bbox="576 1664 887 1693">For description, see "TV-A"</p>

Operating elements

Icon	Function
	Stop the measurement Interrupts the measurement and shows the last measured values in the diagram and the displays
	Measurement stopped Indicates that the measurement has been stopped
	Switch to Y/t graph Displays the Y/t graph instead of the X/Y graph
Z1	Check the commutation signals Shows the commutation signals C and D
 ... / RI	Show reference signal Displays the measured values for the reference signal
	Activate a filter Suppresses interfering signals ≥ 100 kHz
	Reset status displays Resets the status displays of signal monitoring (Sig Mon) back to "green"
	Activate comparison circle Retains the current signal circle in the X/Y diagram while the measurement is continued with a new signal circle
	Activate persistence Retains a defined number of measured values in the diagram (persistence mode)
	Transfer data to the Protocol view Transfers the displayed data to the Protocol view
HSP	Deactivate HSP Deactivates the HEIDENHAIN Signal Processing (HSP) function
	Sampling rate [kS/s] Specifies the sampling rate
	Number of samples Specifies the number of samples
	Notes Indicates that there is new information on the current measurement

Sampling rate

The value in the **Sampling rate** field defines the clock rate at which the analog signals are measured and converted.

Unit:	Kilosamples per second (kS/s)
	1 kS/s = 1,000 signal conversions per second
Default setting:	100 kS/s
Setting range:	1 ... 1,800 kS/s

i The optimum sampling rate depends on the signal frequency (see **Freq** value in the **Encoder characteristics** section). The signal frequency increases with the traversing speed or shaft speed of the encoder.

Recommended value:
Sampling rate = 10 · maximum signal frequency

If the sampling rate is too low, the original signal will be distorted:

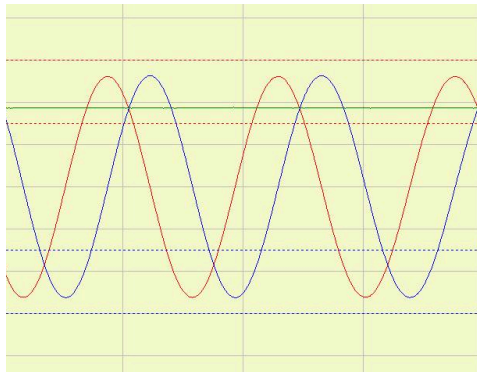

Sufficiently high sampling rate with correct signal shape

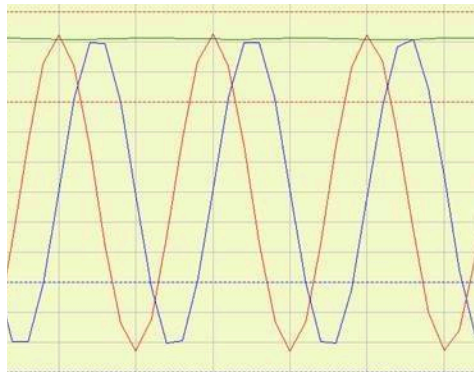

Sampling rate too low with falsified signal shape; correct evaluation is not possible

i When you exit the **Incremental signal** function, the **sampling rate** is reset to default.

Number of samples

The value in the **Number of samples** field defines how many measured values are displayed in the diagram.

Default setting: 2,000
Setting range: 2,000 ... 100,000

i The optimum value depends on the signal frequency (see **Freq** value in the **Encoder characteristics** section). The signal frequency increases with the traversing speed or shaft speed of the encoder. The higher the signal frequency, the lower you should set the value in the **Number of samples** field.

i A high value in the **Number of samples** field allows you to locate signal drops by determining the envelope curve over several signal periods.

i When you exit the **Incremental signal** function, the value in the **Number of samples** field is reset to default.

9.2.3 Examining the incremental signals A and B (Analog view)

i A warning symbol appears in the control bar when there are notes. Delete existing notes before you start the examination.
Further information: "Displaying and deleting notes (Note view)", Page 136



- ▶ Click **Reset status displays** to reset the status of the signal monitoring
- ▶ The **Sig Mon** status displays are green
- ▶ Enter the desired value in the **Sampling rate** field
- ▶ Enter the desired value in the **Number of samples** field
- ▶ Traverse the entire measuring range
- ▶ The Adjusting and Testing Software acquires the measured values at the specified sampling rate
- ▶ The diagram and the bar display show the measured values and tolerances of the signals A and B

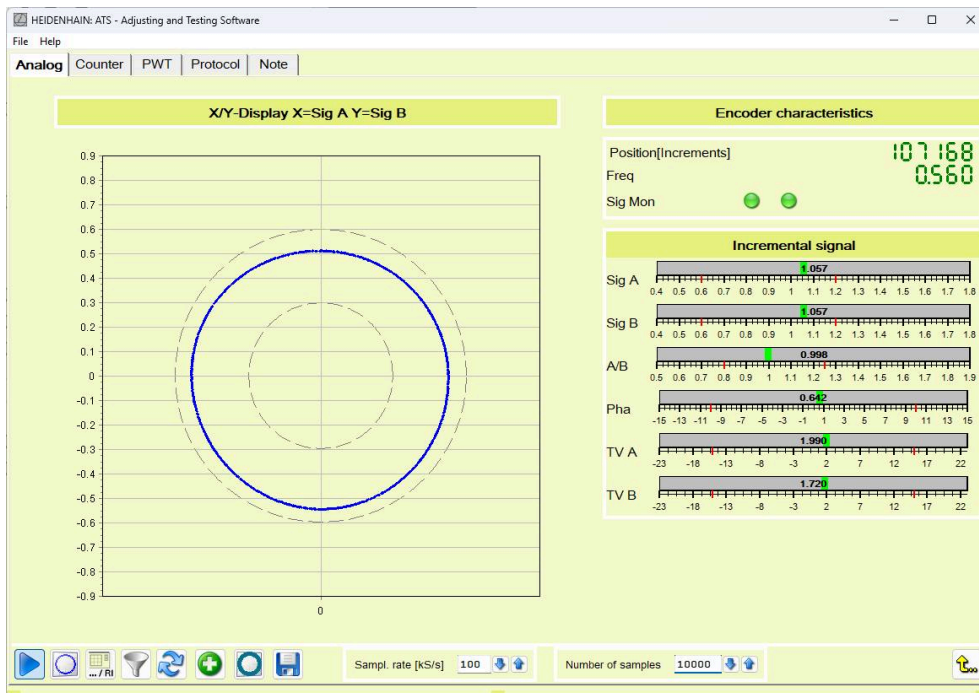

Figure 35: **Analog** screen of the **Incremental signal** function

i You can save and print the active diagram.
Further information: "Adjusting, exporting and printing diagrams", Page 48

i To examine a section more closely, you can zoom in on the diagram view.
Further information: "Magnifying the diagram view", Page 48

Switching between the diagrams



- ▶ Click **Switch to Y/t graph**
- The Y/t graph is displayed

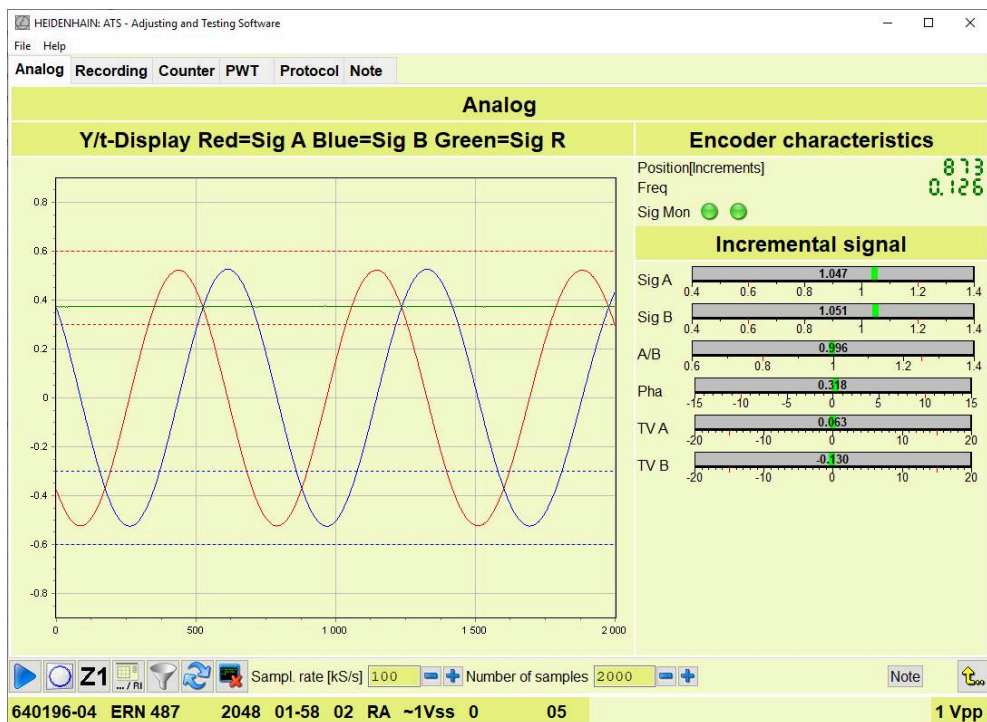

Figure 36: **Analog** view with Y/t graph



- ▶ Click the operating element again to return to the X/Y graph

Stopping the measurement

You can stop the measurement to analyze a specific point or take a screenshot.



- ▶ Click **Stop measurement** in the control bar
- The diagram and the displays hold the last measured values



- ▶ Click the operating element again to continue the measurement

Activating a filter

For special adjustments, you can activate a filter suppressing interference frequencies ≥ 100 kHz by attenuating the bandwidth of the input amplifier.



Activate the filter in exceptional cases only and use the full bandwidth of the PWM for standard measurements.



- ▶ Click **Activate filter** in the control bar
- Interference frequencies ≥ 100 kHz are suppressed
- ▶ Click the operating element again to deactivate the filter

Activating the comparison circle

To make signal fluctuations better visible, you can activate the comparison circle in the X/Y diagram. The comparison circle is a snapshot of the current signal circle. The comparison circle is kept in the diagram while the measurement continues with a new signal circle.



- ▶ Click **Activate comparison circle** in the control bar
- The current signal circle is held in the diagram

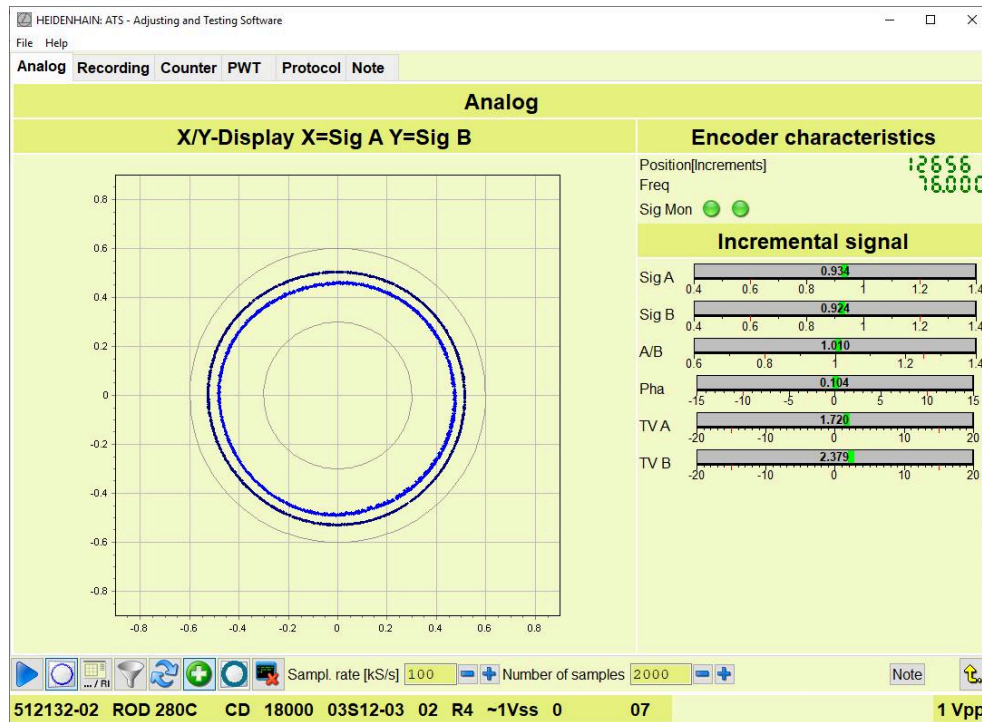

Figure 37: X/Y graph with comparison circle



- ▶ Click the operating element again to discard the comparison circle

Activating persistence

To make signal fluctuations better visible, you can activate persistence in the X/Y diagram. By this means, measured values are added continuously when the encoder is traversed. A maximum of 10,000 measured values can be shown simultaneously in the diagram. The progress bar indicates the percentage of diagram memory occupied. When 10,000 measured values are reached, the oldest values will be overwritten.



- ▶ Click **Activate persistence** in the control bar
- ▶ Traverse the encoder
- ▶ Measured values are continuously added to the Y/X diagram

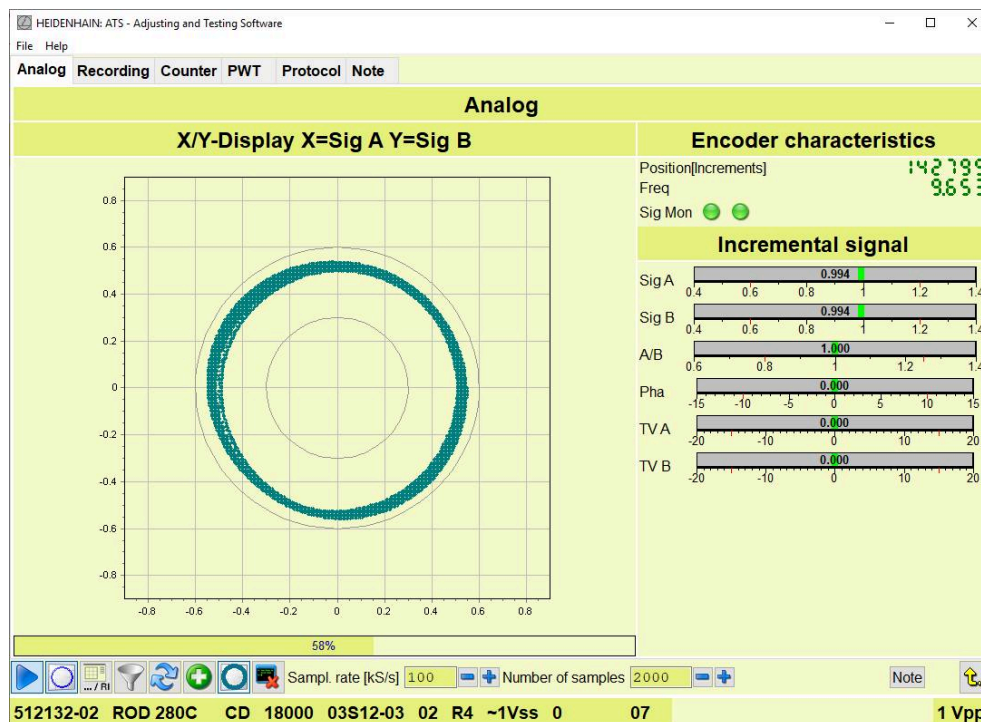



Figure 38: X/Y diagram with active persistence



- ▶ Click the operating element again to deactivate persistence

Deactivating HEIDENHAIN Signal Processing (HSP)

Some encoders are equipped with the **HEIDENHAIN Signal Processing ASIC HSP**. If contamination on the measuring standard or scanning reticle result in signal changes, this ASIC almost completely compensates them. The result is a permanently stable measuring signal. For mounting and adjusting the encoder, you need to deactivate the HSP function.

 Refer to the mounting instructions for the specific encoder. The cabling must support all signals as per the mounting instructions, e.g. the PWT signal.

- HSP**
- ▶ Click **Deactivate HSP** in the control bar
 - The blinking message **HSP off** is shown
 - The diagram and displays are updated

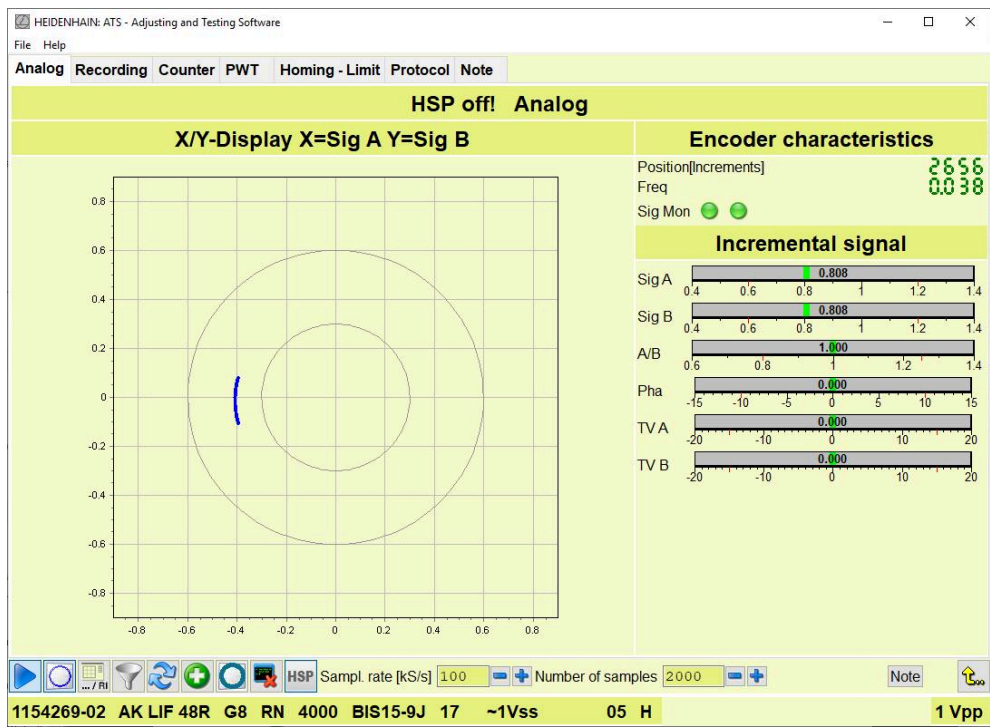

Figure 39: **Incremental signal** function with deactivated HSP function

- HSP**
- ▶ Click the operating element again to reactivate the HSP function

 When you exit the **Incremental signal** function, the HSP function is automatically reactivated.

Transferring data to the Protocol view

You can transfer the displayed data to the **Protocol** view and save them later on as a log file (PDF format).

i The data are temporarily retained in the **Protocol** view until you exit the **Incremental signal** function.



- ▶ To store data temporarily, click on **Transfer data to the Protocol view**
- The Adjusting and Testing Software displays the **Protocol** view with the buffered values

Further information: "Protocol view", Page 134

Examples of a faulty encoder

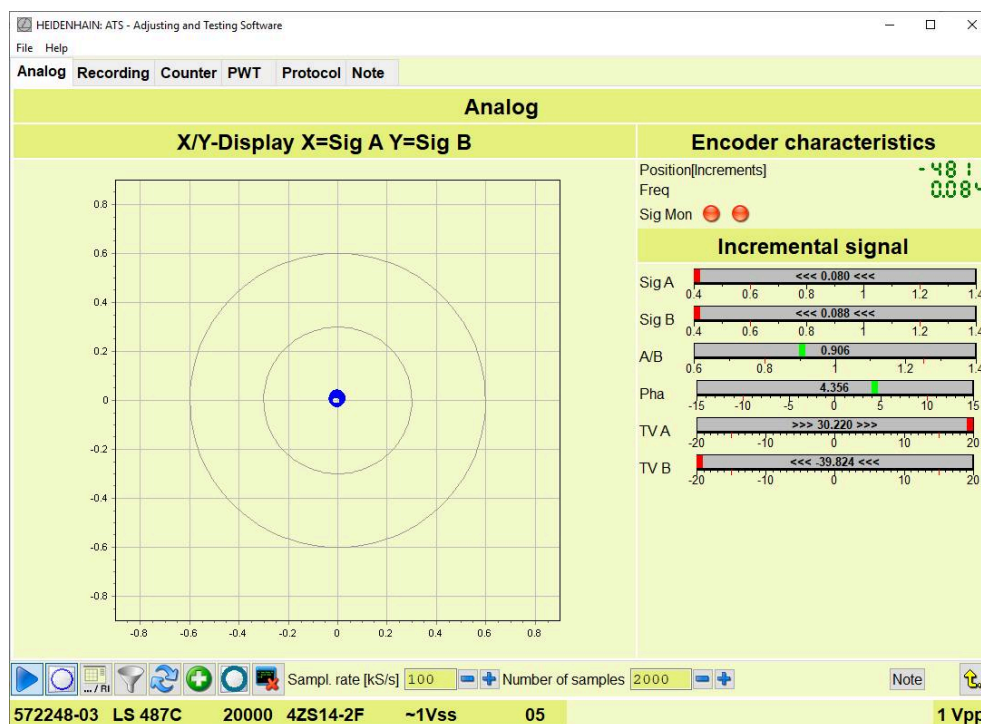

Figure 40: **Analog** view with X/Y graph

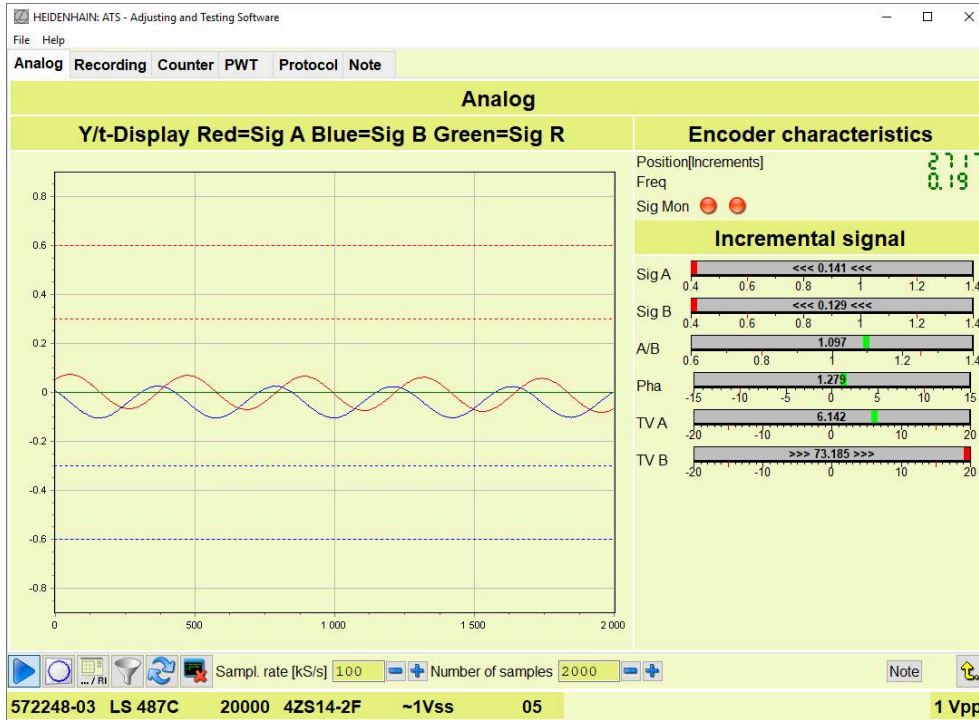



Figure 41: Analog view with Y/t graph

9.2.4 Checking the reference signal (Analog view)

You can display the reference signal in the **Analog** view to check the signal quality and the position of the reference marks. The reference signal is displayed graphically in the Y/t diagram.

 The following information refers to the signal diagrams in the document "Interfaces of HEIDENHAIN Encoders".

Further information: "Opening documentation", Page 47

Recommended sampling rate

Select the sampling rate according to the required display accuracy.

Sampling rate = Maximum frequency · 360° / Display accuracy in degrees

Recommended value: 1°

Further information: "Sampling rate", Page 101

Recommended number of samples

The signal evaluation is based on the values that are displayed in the Y/t diagram. Therefore, select the number of samples such that one complete reference pulse is visible in the diagram when a reference mark is traversed.



Figure 42: Complete reference pulse including quiescent value and usable component

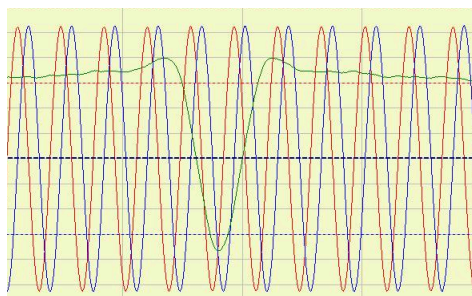

Figure 43: Incomplete reference pulse; correct evaluation is not possible

Further information: "Number of samples", Page 102



For encoders with selectable reference mark (via magnet or selector plate), the quiescent value "H" must also be visible in the diagram.



▶ Click **Switch to Y/t graph**



▶ Click **Show reference signal**

> The **Reference signal** section is shown

▶ Enter the desired value in the **Sampling rate** field

▶ Enter the desired value in the **Number of samples** field

▶ Traverse the reference mark

> As soon as the reference signal crosses the trigger line, the reference pulse is shown in the Y/t diagram

> The **Reference signal** section shows the values of the traversed reference mark

▶ Traverse further reference marks, if required

> The Y/t graph and the values in the **Reference signal** section are updated each time a reference mark is traversed



The Adjusting and Testing Software records a reference pulse as soon as the reference signal crosses the trigger line. In the diagram, you can adapt the threshold value for reference mark detection by holding the mouse button and dragging the trigger line to the desired position.

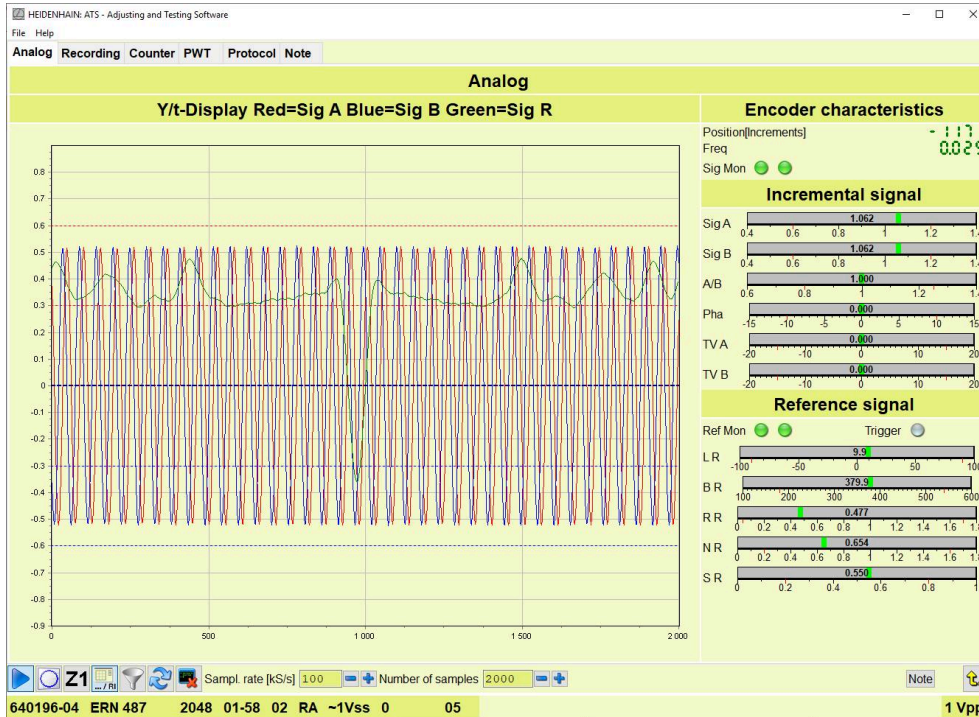

Figure 44: Incremental signal function with reference signal

Depiction	Description
X axis (t)	Number of samples
Y axis	Signal amplitude Unit: volts or microamperes (depending on the interface)
Red curve	Signal A
Blue curve	Signal B
Green curve	Reference signal
Dashed lines in the color of the signals	Tolerance limits of the respective signal
Dark blue dashed line	Trigger line

Reference signal section

Depiction	Description
Ref Mon	Status displays of reference signal monitoring <ul style="list-style-type: none"> ■ Green: no status message available ■ Red: status message available The left status display shows the current status. When a status message is recorded, the status display remains red for about 5 seconds. The right status display shows the overall status of the measurement. When a status message is recorded, the status display remains permanently red.

Depiction	Description
Trigger	Status display of reference mark detection <ul style="list-style-type: none"> ■ Gray: no reference mark was detected ■ Green: a reference mark was detected When a reference mark was detected, the status display changes back to gray color after 5 seconds. If several reference marks follow each other, the status display may be permanently green.
LR	Position of the reference pulse Formula: $(K - L) / 2$
BR	Width of the reference pulse Formula: $K + L$
RR	Quiescent value H of the reference pulse
NR	Usable component G of the reference pulse
SR	Switching threshold of the reference pulse Formula: E / G

i Traverse the reference mark(s) in both directions. Perform spot checks on encoders with distance-coded reference marks and check defective areas several times.

i You can transfer the displayed data to the **Protocol** screen and save them later on as a log file (PDF format).
Further information: "Transferring data to the Protocol view", Page 108

9.2.5 Checking commutation signals C and D (Analog view)

The incremental signals A and B are generated by the incremental track Zn. Some encoders feature an additional incremental track Z1, providing one sine signal (C) and one cosine signal (D) per revolution. For electronic commutation, the rotor position can thus already be determined before the motor is started.

Incremental track	Characteristics
Zn: signals A and B	High resolution: One revolution corresponds to e.g. 2048 signal periods (depends on encoder)
Z1: signals C and D	Low resolution: One revolution corresponds to one signal period

You can check the commutation signals C and D in the **Analog** view.

Preconditions:

- The encoder was connected to the Adjusting and Testing Software by entering the encoder ID
or
- The interface type **1 V_{pp} + Z1** was selected during manual connection

Recommended sampling rate and number of samples

The signal evaluation is based on the values that are displayed in the diagram. One complete signal amplitude must be recorded in order that PHA, TV A and TV B can be calculated. Select the sampling rate and the number of samples such that a full circle is displayed in the X/Y diagram when the encoder is traversed.

Check of commutation signals

Z1

- ▶ Click **Check commutation signals** in the control bar
- The diagram and the displays show the measured values and tolerances of the signals C and D

i The further procedure is the same as for checking the incremental signals A and B. Below you will find a description of the differences in diagrams and displays.

X/Y graph

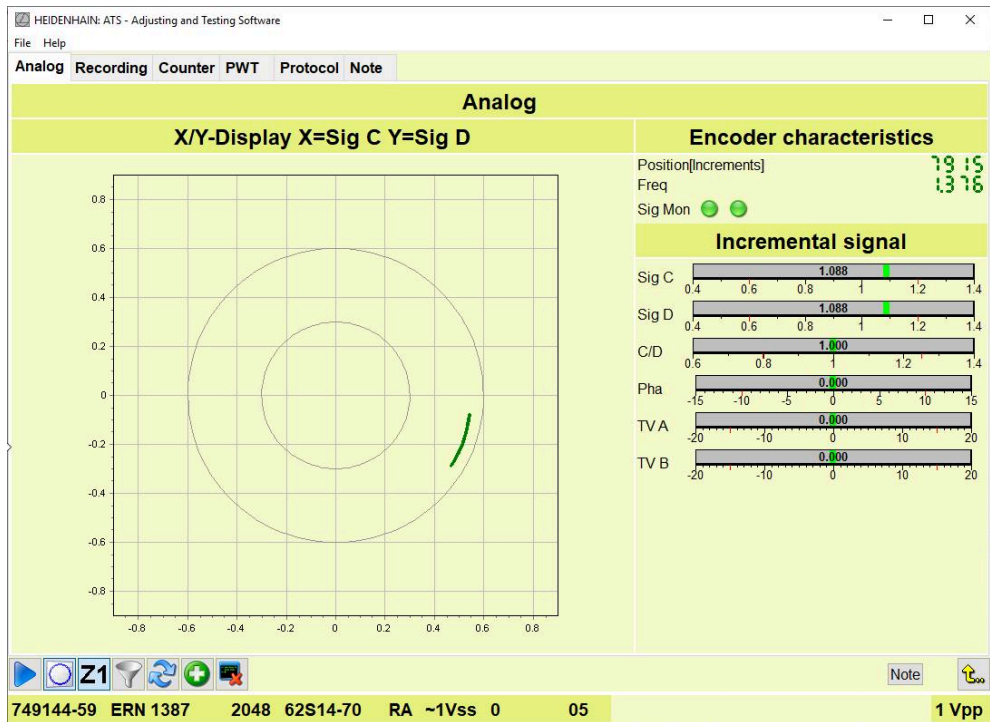

Figure 45: X/Y graph when checking the commutation signals C and D

Depiction	Description
X axis	Amplitude of signal C Unit: volts
Y axis	Amplitude of signal D Unit: volts
Inner and outer circle	Tolerance limits of signals C and D
Green circle	Signal circle of signals C and D

Incremental signal section

Depiction	Description
Sig C	Amplitude of signal C Unit: volts
Sig D	Amplitude of signal D Unit: volts
C/D	Signal ratio of signal C to signal D Signal ratio = C / D Optimum condition: Signal ratio = 1

Y/t graph and Z1/Zn graph

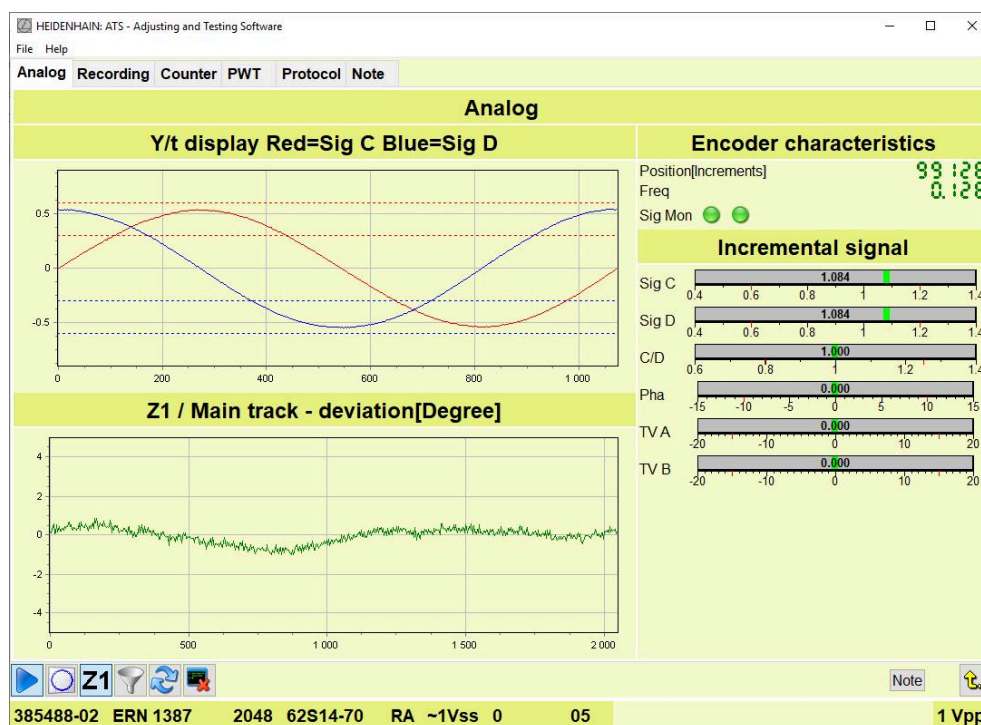

Figure 46: Y/t graph and Z1/Zn graph when checking the commutation signals C and D

The Z1/Zn graph is displayed in addition to the Y/t graph. The Z1/Zn graph shows the deviations between the calculated position values of Z1 track and Zn track. In optimum condition, the curve is close to the zero line.

Depiction	Description
X axis	Line count of the encoder per revolution
Y axis	Angle deviation Unit: degrees



The scale corresponds to the maximum deviation for HEIDENHAIN rotary encoders.

9.2.6 Counter view

In the **Counter** view, you can check the counting function and the reference function of incremental encoders. The **Counter** view shows the distances between the reference marks as the encoder moves.

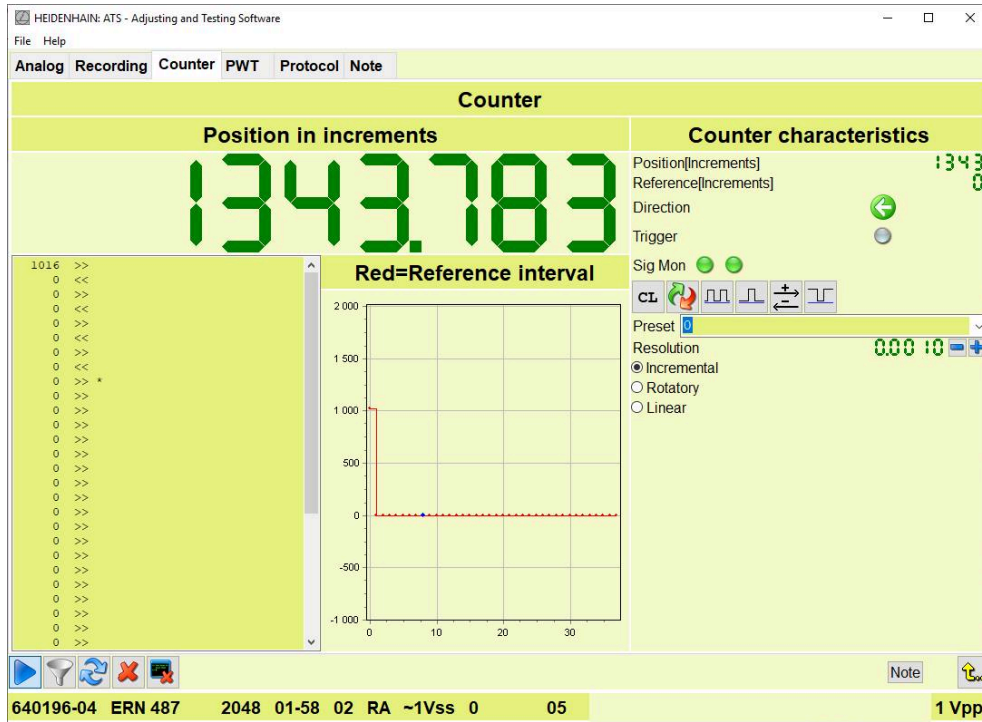

Figure 47: Counter view of the Incremental signal function

Table

When a reference mark is passed over, the distance to the preceding reference mark is determined and an entry added to the table. The table contains the following information:

- The asterisk marks the count value at the current position
- The arrows show the direction of traverse
- With distance-coded reference marks, the nominal increment is shown in addition to the count values

Bar graph

Depiction	Description
X axis	Number of captured reference marks
Y axis	Number of signal periods
Red	Reference mark spacing
Blue	Current position

Counter section

Display	Description
Position in [unit]	Current count of the incremental counter Unit: Depends on the settings in the Counter characteristics section

Counter characteristics section















Display	Description
Position [increments]	Current count Unit: increments
Reference [increments]	Distance between the two reference marks traversed last Unit: increments
Direction	The arrow shows the traverse direction <ul style="list-style-type: none"> ■ Arrow to the right: positive count value recorded ■ Arrow to the left: negative count value recorded
Trigger	Status display of reference mark detection <ul style="list-style-type: none"> ■ Gray: no reference mark was detected ■ Green: a reference mark was detected <p>When a reference mark was detected, the status display changes back to gray color after 5 seconds. If several reference marks follow each other, the status display may be permanently green.</p>
Sig Mon	Status display of signal monitoring <ul style="list-style-type: none"> ■ Green: The signal amplitudes are within the tolerance range ■ Red: The signal amplitudes exceed at least one tolerance limit <p>The left status display shows the current status. When a tolerance limit is exceeded, the status display turns red for about 5 seconds.</p> <p>The right status display shows the overall status of the measurement. When a tolerance limit is exceeded, the status display is permanently red.</p>

Settings in the Counter characteristics section

In the **Counter characteristics** section you can adjust the settings for the counter value display **Position in [unit]**. The position value is calculated according to these settings.

Display	Description
Preset	Input field for presetting a count value
Resolution	Counter resolution
<ul style="list-style-type: none"> ■ Incremental ■ Rotatory ■ Linear 	Type of incremental counter The count value is converted into the corresponding unit as per the selection: <ul style="list-style-type: none"> ■ Incremental: Measuring steps ■ Rotatory: Selected unit (see below); Standard setting: Degrees ■ Linear: Micrometers Depending on the selection, the following settings are displayed.
Line count	Input field for the encoder line count per revolution to calculate the count value
<ul style="list-style-type: none"> ■ Degrees ■ Radian measure ■ DMS 	Unit of the incremental counter The value of the incremental counter is converted into the selected unit. <ul style="list-style-type: none"> ■ Degrees ■ Radian measure ■ DMS: Degrees, minutes, seconds
Signal period	Input field for the length of a signal period to calculate the count value

Operating elements

Icon	Function
	Stop the measurement Interrupts the measurement and shows the last measured values in the diagram and the displays
	Measurement stopped Indicates that the measurement has been stopped
	Activate a filter Suppresses interfering signals ≥ 100 kHz
	Reset status displays Resets the status displays of signal monitoring (Sig Mon) back to "green"
	Delete measured values Deletes the measured values recorded from the table and graphics
	Transfer data to Protocol view Transfers the displayed data to the Protocol view
	Deactivate HSP Deactivates the HEIDENHAIN Signal Processing (HSP) function
	Clear the counter Sets the counter to zero
	Preset the count value Loads the value from the Set field as new count value
	Clear the counter with every reference mark Activates zero reset of count value and position each time a reference mark is traversed
	Clear the counter and start with next reference mark Sets counter and position to zero and starts capture when the next reference mark is traversed
	Clear the counter and determine the position again Sets counter and position to zero and redetermines the position via the distance-coded reference marks
	Invert counting direction Inverts the positive or negative counting direction
	Evaluate the inverted reference pulse Inverts the evaluation of the reference pulse
	Notes Indicates that there is new information on the current measurement

9.2.7 Checking the counting function (Counter view)



- ▶ Double-click **Incremental signal** in the function menu
- ▶ Click the **Counter** tab to switch to the **Counter** view

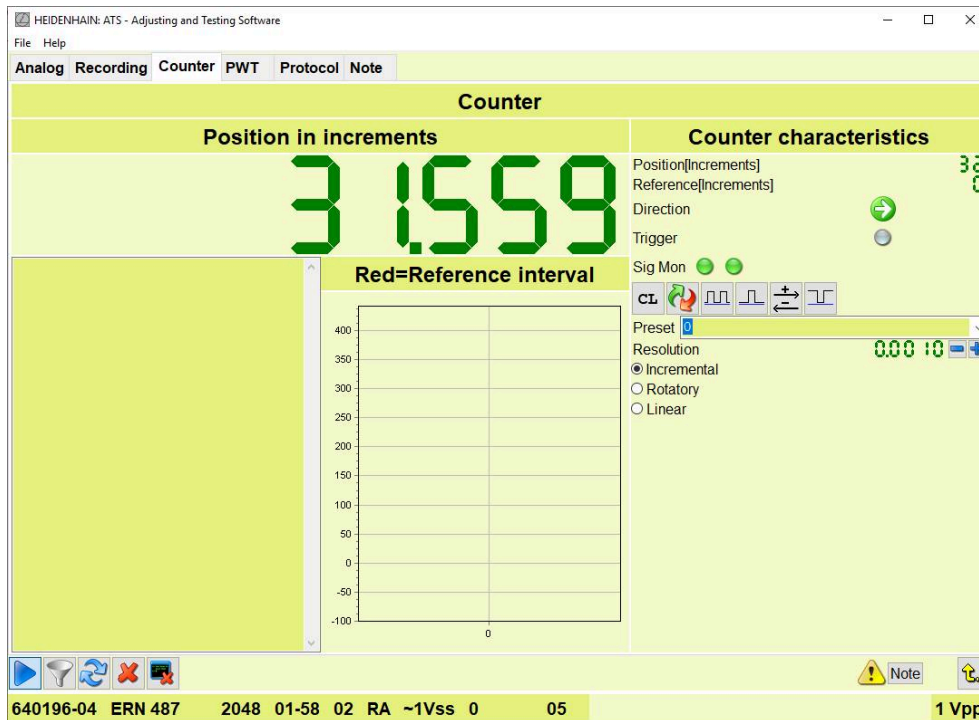

Figure 48: Counter view of the Incremental signal function



The further procedure depends on the type of reference marks the encoder features.

Procedure with one reference mark

- ▶ Traverse the reference mark
- ▶ Traverse the reference mark in the opposite direction
- ▶ Repeat the procedure several times
- ▶ A measured value is added to the table and the diagram each time the reference mark is traversed

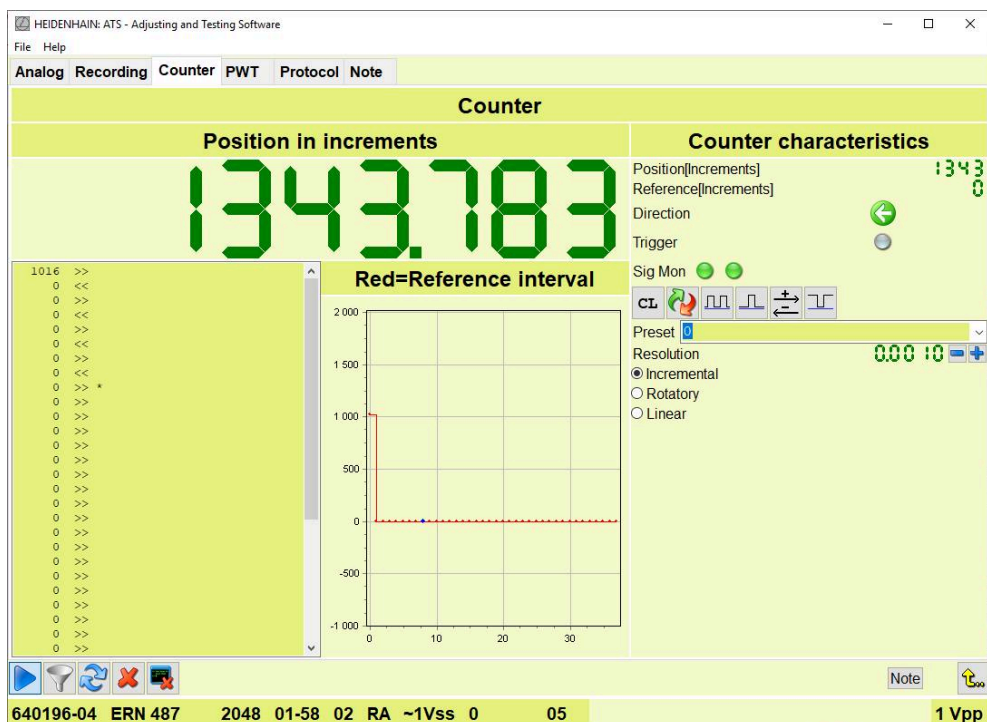

Figure 49: **Counter** view when examining an encoder with one reference mark

i Counter and reference functions are error-free if the distance is "0" each time the reference mark is traversed.

i You can transfer the displayed data to the **Protocol** screen and save them later on as a log file (PDF format).

Further information: "Transferring data to the Protocol view", Page 108

Procedure with multiple reference marks without distance coding

- ▶ Traverse several reference marks
- A measured value is added to the table and the diagram each time a reference mark is traversed
- ▶ Traverse the reference marks in the opposite direction
- When the direction is reversed, the value "0" is added to the table and the diagram

i Counter and reference functions are error-free if the spacing is the same between all reference marks.

i You can transfer the displayed data to the **Protocol** screen and save them later on as a log file (PDF format).

Further information: "Transferring data to the Protocol view", Page 108

Procedure with distance-coded reference marks

When you examine encoders with distance-coded reference marks, the Adjusting and Testing Software first determines the nominal increment.

- ▶ Traverse several reference marks to determine the nominal increment
- ▶ If the traverse path of the encoder is short, you may need to traverse it in both directions repeatedly
- ▶ After the Adjusting and Testing Software has determined the nominal increment, the table also includes the nominal increment and the position

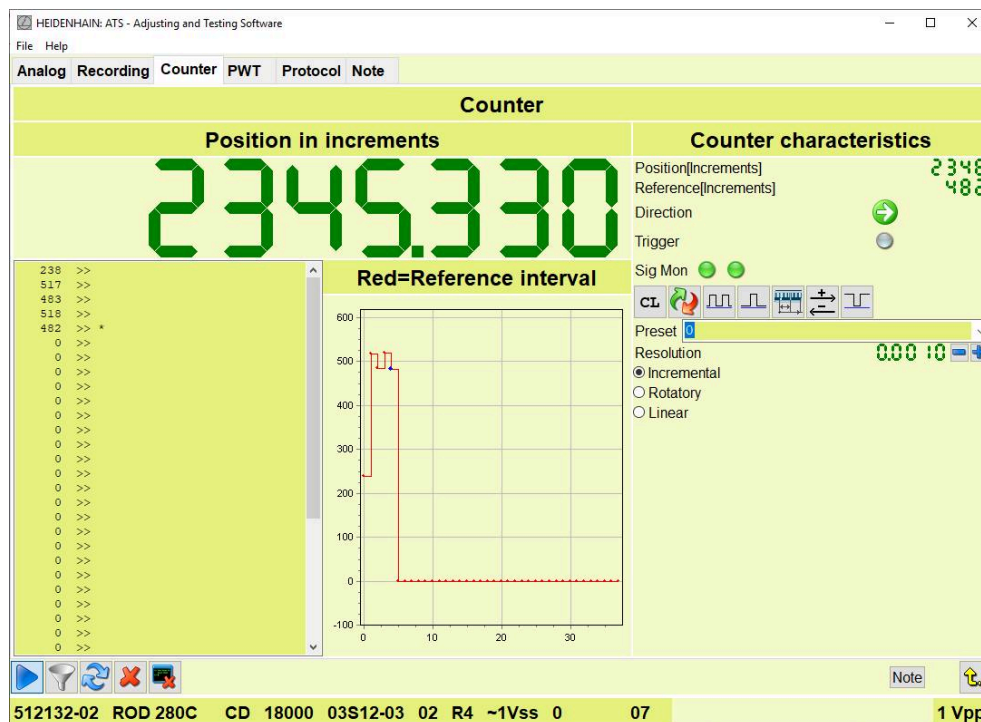

Figure 50: Display during determination of nominal increment

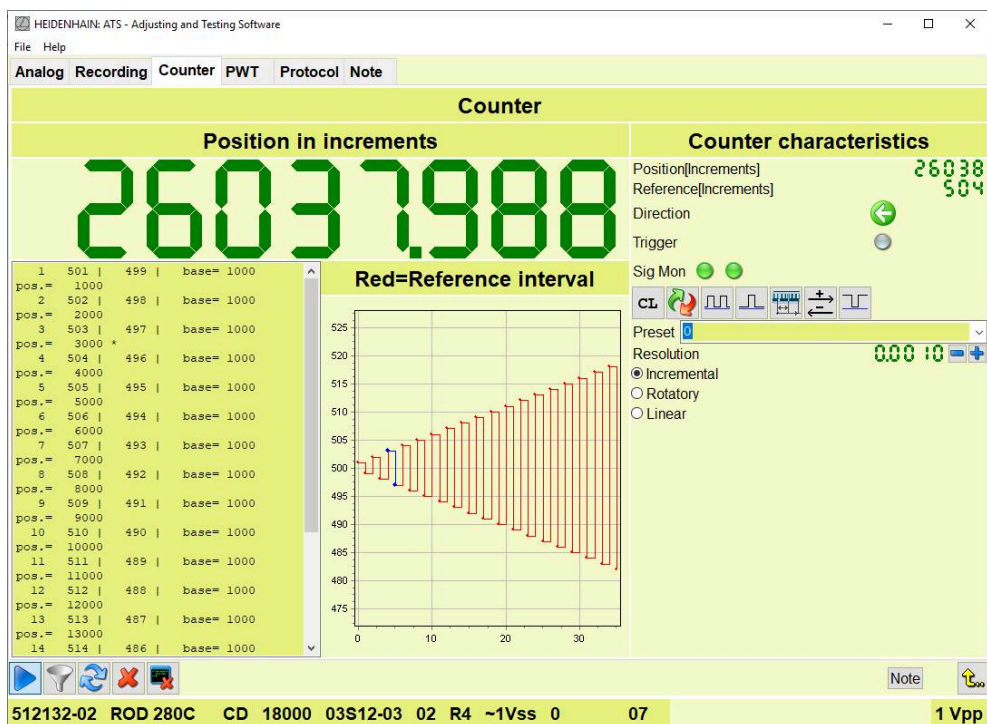

Figure 51: Display after the nominal increment has been determined

Column	Description
1	Reference mark spacing 1
2	Reference mark spacing 2
3	base: Nominal increment
4	pos.: Position determined from distance coding
5	Value "Direction!": Appears if the counting direction determined from the incremental signals differs from the sequence of reference mark spacings 1,2

- ▶ Traverse the entire measuring range
- A measured value is added to the table and the diagram each time a reference mark is traversed
- ▶ Traverse the reference marks in the opposite direction
- When the direction is reversed, the value "0" is added to the table and the diagram

i Counter and reference functions are error-free if the determined distances are the same as the actual distance coding of the encoder. The sum of the values in the columns 1 and 2 must correspond to the nominal increment (value in column 3).

i Deviations indicate a malfunction or improper mounting of the encoder.

i If the value "Direction!" is shown in the last column, check the counting direction and the encoder wiring.

i You can transfer the displayed data to the **Protocol** screen and save them later on as a log file (PDF format).

Further information: "Transferring data to the Protocol view", Page 108

Adjusting the counter display

The counter display can be adjusted in the **Counter characteristics** section.

- ▶ Set the desired counter resolution with the plus and minus buttons
- ▶ Select desired display options:
 - **Incremental**: Count value is displayed in increments
 - **Rotatory**: Count value is displayed in the selected angle unit
 - **Degrees**
 - **Radian measure**
 - **DMS** (degrees, arc minutes, arc seconds)
 - **Linear**: Count value is displayed in micrometers
- ▶ If you select **Rotatory**, enter the line count per encoder revolution in the **Line count** field
- ▶ If you select **Linear**, enter the length of a signal period in micrometers in the **Signal period** field
- ▶ The count value is converted and displayed according to the setting



A warning symbol appears in the control bar when there are notes. Delete existing notes before you start the examination.

Further information: "Displaying and deleting notes (Note view)", Page 136

Presetting the count value

To compare the counter e.g. with the counter of the subsequent electronics, you can preset a certain count value at the current position.



- ▶ Enter the desired position value in the **Preset** field
- ▶ Click **Preset count value** in the control bar
- ▶ The entered count value is adopted as the new position

Clearing the counter



- ▶ Click **Clear counter** in the control bar
- ▶ The counter is set to zero

Clearing the counter with every reference mark



- ▶ To start counting at every reference mark, click **Clear counter with every reference mark** in the control bar
- ▶ The counter is set to zero each time a reference mark is traversed

Clearing the counter and starting with next reference mark



- ▶ Click **Clear counter and start with next reference mark** in the control bar
- ▶ The counter is set to zero and will start counting when the next reference mark is traversed

Inverting the counting direction

The counting direction of some encoders can be configured. You can adapt the counting direction to the encoder in the Adjusting and Testing Software.



- ▶ Click **Invert counting direction** in the control bar to adapt the counting direction
- > The Adjusting and Testing Software inverts the positive or negative counting direction

Clearing the counter and determining the position again

For encoders with distance-coded reference marks, you can set the position and the counter to zero and then determine the position again.



- ▶ Click **Clear counter and determine position again** in the control bar
- > The counter is set to zero
- ▶ Traverse several reference marks
- > The position is determined again

Evaluating the inverted reference pulse

The reference signal of some encoders is inverted. In order that inverted reference pulses can be detected and correctly evaluated, you need to adapt the evaluation logic of the Adjusting and Testing Software.



- ▶ Click **Evaluate inverted reference pulse** in the control bar
- > The Adjusting and Testing Software inverts the evaluation logic

Deleting measured values

For a new examination you can delete the recorded measured values from the table and from the diagram.



- ▶ Click **Delete measured values** in the control bar
- > The table and the diagram are reset

9.2.8 PWT view

The **PWT** view allows for a rapid test of incremental signals and reference mark signals. The results are displayed graphically as bar graphs.

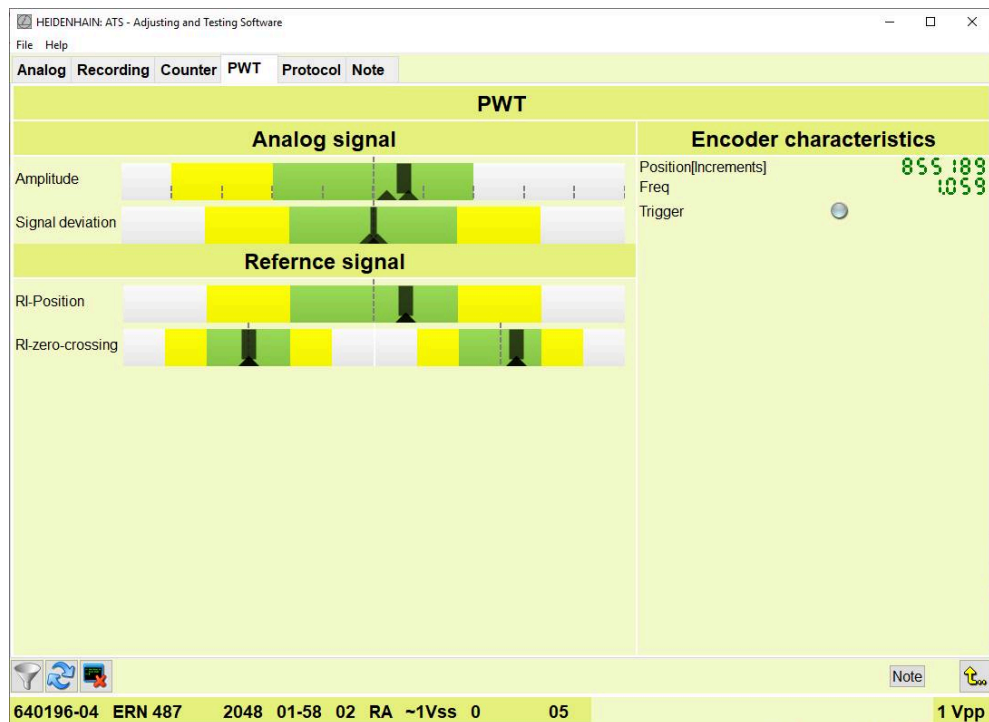

Figure 52: **PWT** view of the **Incremental signal** function

The following signal characteristics are evaluated in the bar graphs:

- Signal amplitude
- Signal deviation
- RI position: Reference mark position
- RI zero crossing: Zero crossovers of reference-mark signal



The tolerance ranges are indicated by color in the bar graphs:

Image	Tolerance range	Description
Green	Pass	Measured values are within the restricted tolerance range
Yellow	Adequate	Measured values are within tolerance
Gray	Not adequate	Measured values are outside the tolerance range
<<	Out of scale	At least one measured value is beyond the tolerance range and out of scale. The direction of the arrow shows the direction where the measured value lies.
>>		



The shown tolerances are HEIDENHAIN standard values! In certain cases, the tolerance limits of the encoder may differ from the tolerance limits displayed.



Note the tolerances specified in the documentation of the encoder.

Depiction	Description
	The bar shows the current measured value.
	The drag indicators show the minimum and maximum measured values of the measurement.

Depiction	Description
Position [increments]	Count value of incremental counter Unit: Increments
Freq	Input frequency Unit: kHz
Trigger	Status display of reference mark detection <ul style="list-style-type: none"> ■ Gray: no reference mark was detected ■ Green: a reference mark was detected When a reference mark was detected, the status display changes back to gray color after 0.5 seconds. If several reference marks follow each other, the status display may be permanently green.

Signal amplitude bar graph



The position of the black bar indicates the signal amplitude.

Depiction	Description
	Optimum signal amplitude
	Minimum signal amplitude
	Maximum signal amplitude

Signal deviation bar graph

Signal deviations are errors in the signal ratio, on-off ratio and phase shift. The larger the signal deviation is, the broader the black bar becomes.

Optimum condition: The black bar is as narrow as possible and is positioned within the green area.

Depiction	Description
	Optimum condition
	Signal deviation at the tolerance limit
	Signal deviation too large

RI position bar graph

The reference mark signal is at a specified nominal position. The position of the black bar indicates the deviation from the optimum position.







Depiction	Description
	Deviation of reference mark position at the tolerance limit

RI zero crossover bar graph

The positions of two black bars show the deviation of the zero crossovers from the nominal values.

Depiction	Description
	Deviations of the reference pulse zero crossovers within the tolerance range

Operating elements

Icon	Function
	Stop the measurement Interrupts the measurement and shows the last measured values in the diagram and the displays
	Measurement stopped Indicates that the measurement has been stopped
	Activate a filter Suppresses interfering signals ≥ 100 kHz
	Delete measured values Deletes the measured values for a new measurement
	Transfer data to Protocol view Transfers the displayed data to the Protocol view
	Deactivate HSP Deactivates the HEIDENHAIN Signal Processing (HSP) function
	Notes Indicates that there is new information on the current measurement

9.2.9 Running a rapid test with the PWT test function (PWT view)



- ▶ Double-click **Incremental signal** in the function menu
- ▶ Click the **PWT** tab to switch to the **PWT** view

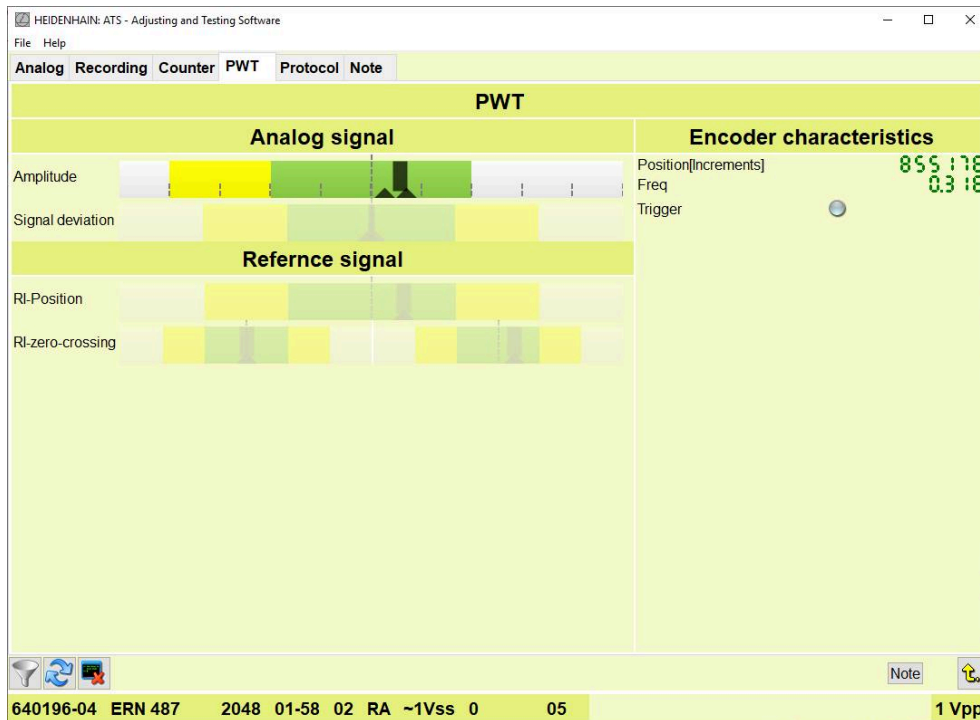

Figure 53: **PWT** view of the **Incremental signal** function

i A warning symbol appears in the control bar when there are notes. Delete existing notes before you start the examination.
Further information: "Displaying and deleting notes (Note view)", Page 136

- ▶ Traverse the entire measuring range
- ▶ The **Signal deviation** bar graph is activated
- ▶ When a reference mark is traversed, the bar graphs **RI position** and **RI zero crossing** are activated
- ▶ The bar graphs show the current measured values
- ▶ To reset the minimum and maximum value for a new measurement, click **Delete measured values** in the control bar
- ▶ The drag indicators are reset to the current measured value



i If the encoder stops for several seconds, the bar graphs for **Signal deviation**, **RI position** and **RI zero crossing** become inactive again.

i You can transfer the displayed data to the **Protocol** screen and save them later on as a log file (PDF format).
Further information: "Transferring data to the Protocol view", Page 108

9.2.10 Homing – Limit view

The **Homing – Limit** view provides a functional check of limit switching signals.

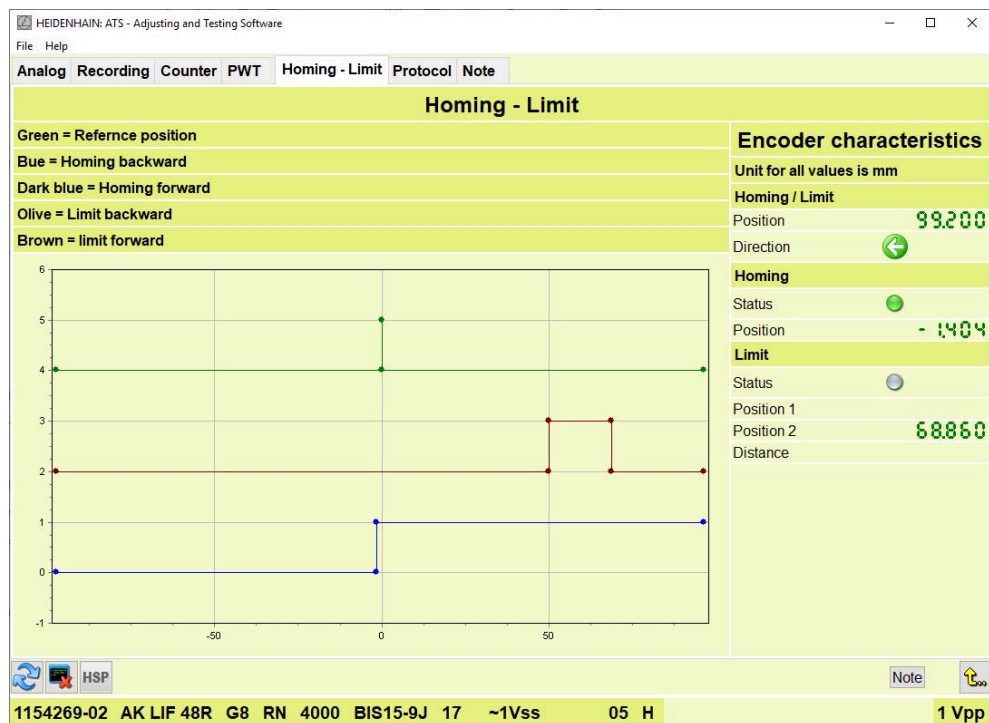

Figure 54: **Homing – Limit** view of the **Incremental signal** function

Bar graph

In the diagram, the signals with their respective traverse directions are color-coded.

Depiction	Description
Green	Reference signal
Blue	Homing backward
Dark blue	Homing forward
Olive green	Limit backward
Brown	Limit forward

Encoder characteristics section

All values in mm

Depiction	Description
Position	Count value of incremental counter Unit: millimeters
Direction	The arrow symbol shows the traverse direction <ul style="list-style-type: none"> ■ Arrow to the right: positive count value recorded ■ Arrow to the left: negative count value recorded





Homing/L1/Pin 6 (depending on encoder)

Depiction	Description
Status	Status display of the homing level <ul style="list-style-type: none"> ■ Gray: low level ■ Green: high level
Position	Distance between homing edge and reference mark R Unit: millimeters

Limit/L2/Pin 8 (depending on encoder)

Depiction	Description
Status	Status display of the limit level <ul style="list-style-type: none"> ■ Gray: low level ■ Green: high level
Position 1	Distance between limit edge 1 and reference mark R Unit: millimeters
Position 2	Distance between limit edge 2 and reference mark R Unit: millimeters
Distance	Distance between limit edge 1 and limit edge 2 Distance = Limit edge 1 + Limit edge 2

Operating elements

Icon	Function
	Delete measured values Deletes the measured values for a new measurement
	Transfer data to Protocol view Transfers the displayed data to the Protocol screen
	Deactivate HSP Deactivates the HEIDENHAIN Signal Processing (HSP) function
	Notes Indicates that there is new information on the current measurement

9.2.11 Checking Limit switching signals (Homing – Limit view)

Preconditions:

- The encoder features limit switching signals
- The encoder is correctly mounted and electrically adjusted according to the mounting instructions
- The encoder was connected to the Adjusting and Testing Software by entering the encoder ID



For detailed information on the availability and function of switching signals, refer to the encoder documentation or the brochure "Interfaces of HEIDENHAIN Encoders".

Further information: "Opening documentation", Page 47



- ▶ Double-click **Incremental signal** in the function menu
- ▶ Click the **Homing – Limit** tab to switch to the **Homing – Limit** view

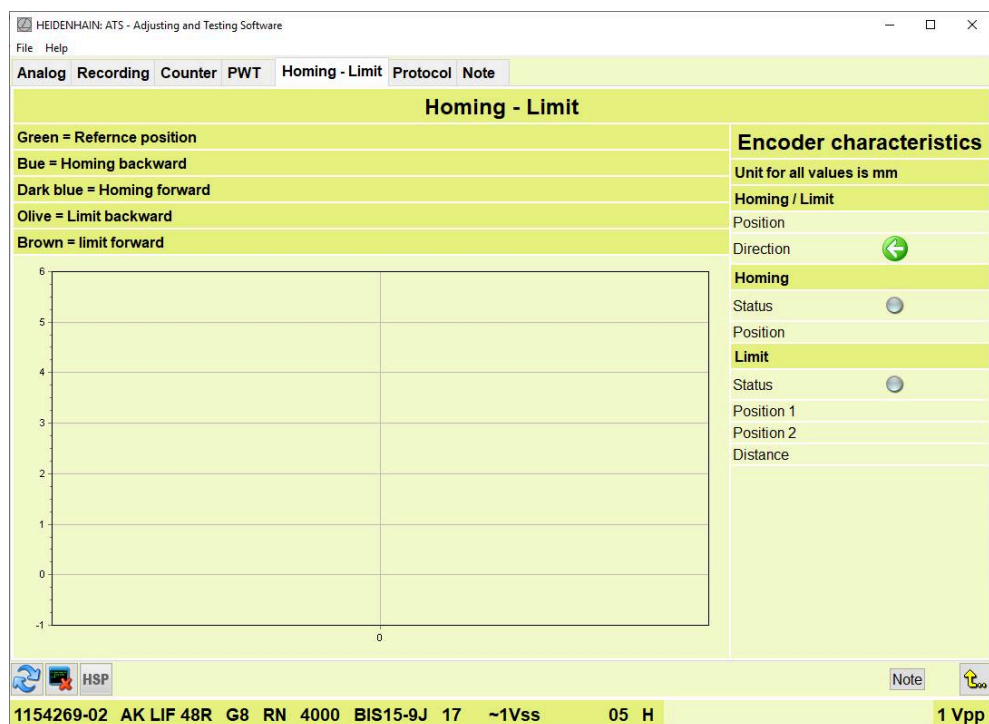

Figure 55: **Homing – Limit** view of the **Incremental signal** function

- ▶ Traverse the entire measuring range
- Recording of the measured values in the diagram starts as soon as the first reference mark is traversed.
- When the last reference mark is traversed, the entire measuring range is displayed in the diagram with homing and limit switching edges (depending on the encoder)

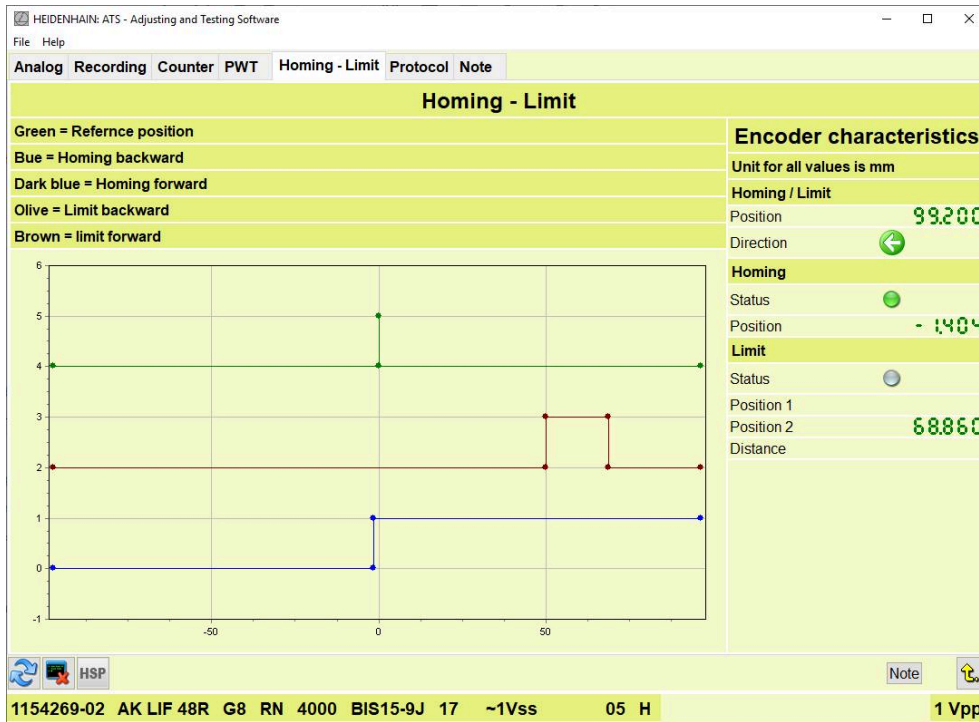

Figure 56: **Homing – Limit** with reference mark and switching edges

i You can transfer the displayed data to the **Protocol** screen and save them later on as a log file (PDF format).
Further information: "Transferring data to the Protocol view", Page 108

i You can save and print the active diagram.
Further information: "Adjusting, exporting and printing diagrams", Page 48



► To reset the diagram for a new measurement, click **Delete measured values** in the control bar

9.2.12 Protocol view

You can transfer data from the views of the **Incremental signal** function to the **Protocol** view.

Further information: "Transferring data to the Protocol view", Page 108

The data recorded in the **Protocol** view can be saved to a PDF file. In the **Selection** field, the **Protocol** view shows the data according to the view in which the data was captured. In the **Comment** field, you can enter notes that will be transferred to the PDF file.



The data are temporarily retained in the **Protocol** view until you exit the **Incremental signal** function.



If there are any test limits for the signal then they are saved to the protocol.

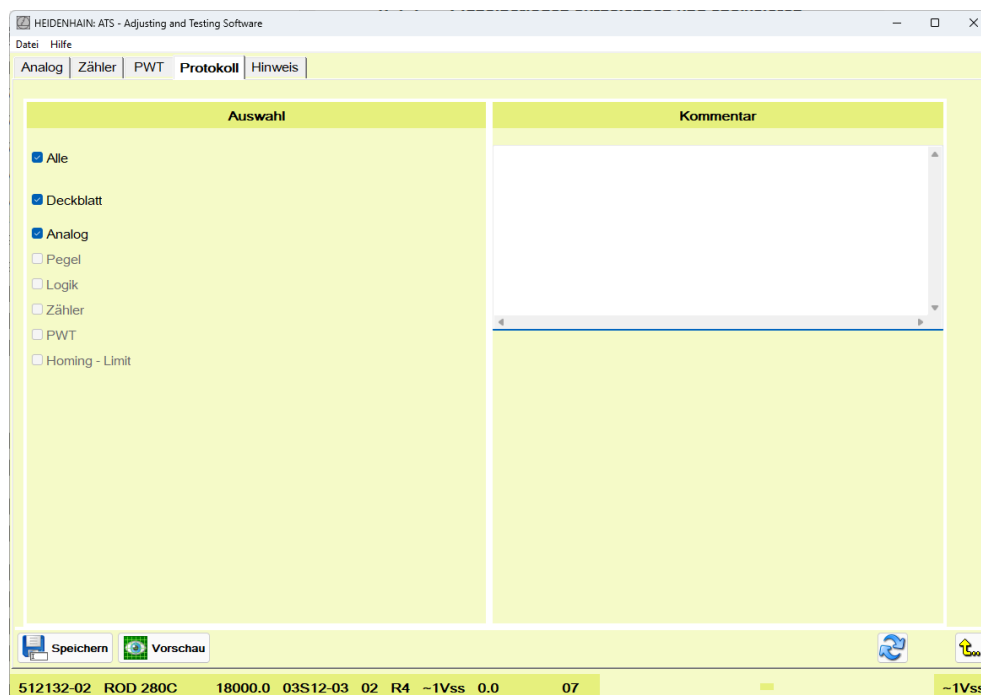

Operating elements

Icon	Function
	Save log Opens the Save file dialog
	Preview Displays a log preview
	Reset a comment Deletes the text in the Comment field

9.2.13 Saving log data (Protocol view)

You can save the test results in a PDF file.

- ▶ Click the **Protocol** tab to switch to the **Protocol** view
- > The selection of the available contents is displayed in the **Selection** field.

Displaying the log preview



- ▶ Click **Preview** to open a preview of the PDF file
- > A new **Preview** window opens and shows the preview
- ▶ Close the **Preview** window to return to the Adjusting and Testing Software

Saving the log



- ▶ Click **Save log**
- ▶ Click **Save** in the dialog box
- ▶ Select the desired storage location
- ▶ Enter the file name
- ▶ Click **Save**
- > The file is saved



In the Adjusting and Testing Software, you can add an individual header and details on the examiner to the logs.

Further information: "Saving log information", Page 57



To display the PDF contents correctly, the font "Arial Unicode MS" must be installed on the computer.

9.2.14 Note view

The **Note** screen contains information on the current measurement.

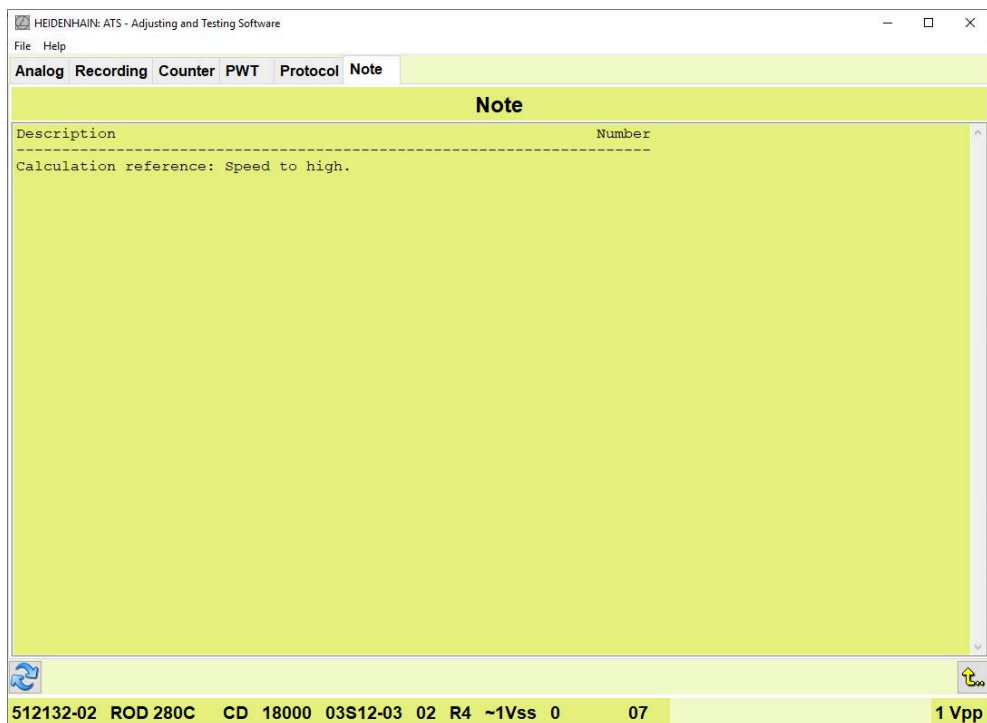



Figure 57: **Note** view of the **Incremental signal** function

The notes refer to problems with signal calculation, e.g.:

- Signal frequencies are too high, e.g. due to excessive traversing speed or shaft speed
- Signal frequency fluctuates
- Displayed signal detail is too small to calculate the reference mark correctly

Operating elements

Icon	Function
	Delete notes Deletes the notes for a new measurement

9.2.15 Displaying and deleting notes (Note view)



A warning symbol appears in the control bar when there is a new note. Go to the **Note** view to read the note.

- ▶ Click **Note** in the control bar
- The **Note** view shows a list of all notes



Notes are retained until you exit the **Incremental signal** function or delete the notes by hand.

Deleting notes



- ▶ Click **Delete notes** in the control bar to delete all notes

9.3 Recording and analyzing incremental signals

9.3.1 Recording function

With the **Recording** function, you can record several signal periods of the incremental signals and analyze them using the diagram view. You can individually define the number of signal periods to be recorded per measurement and the sampling rate for recording.

i Some functions of the Adjusting and Testing Software are only available if you connect the encoder through its encoder ID (recommended procedure).

i The displayed tolerances are the HEIDENHAIN standard values (depending on the encoder).
Further information: "Units and tolerances", Page 36



► To call this function, double-click **Recording** in the function menu

9.3.2 Recording view

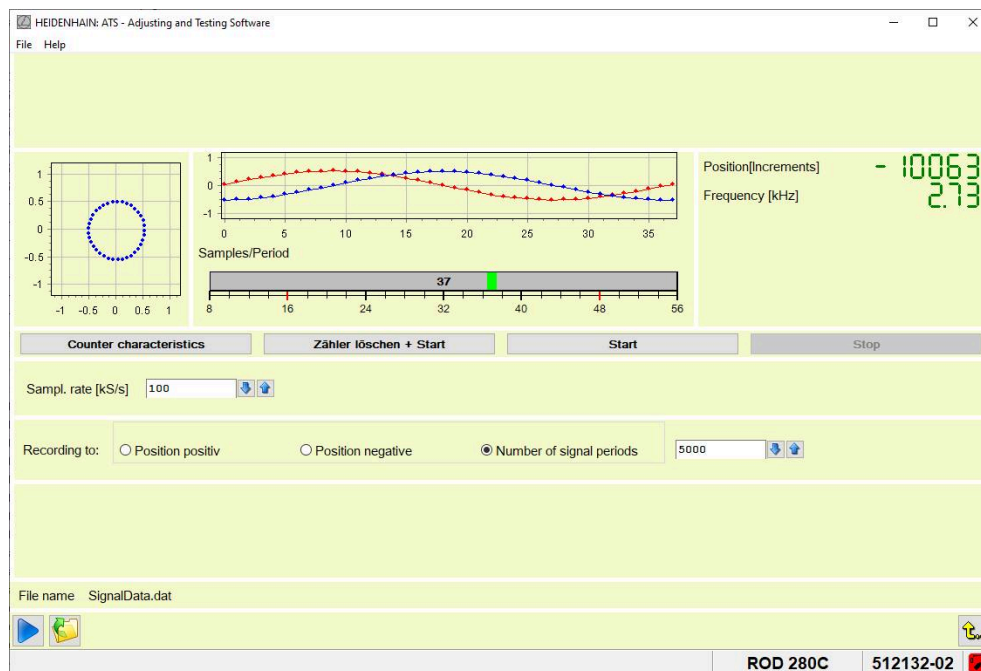

Figure 58: **Recording** function

X/Y graph

Figure 59: X/Y graph

Depiction	Description
X axis	Amplitude of signal A Unit: volts or microamperes (depending on the interface)
Y axis	Amplitude of signal B Unit: volts or microamperes (depending on the interface)
Blue circle	Signal circle of signals A and B

Y/t graph

Figure 60: Y/t graph

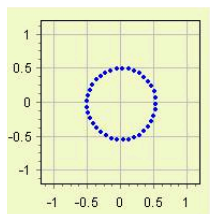
Depiction	Description
X axis (t)	Number of samples
Y axis	Signal amplitude Unit: volts or microamperes (depending on the interface)
Red curve	Signal A
Blue curve	Signal B

Samples/Period

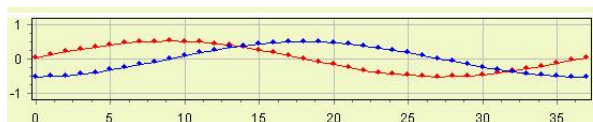
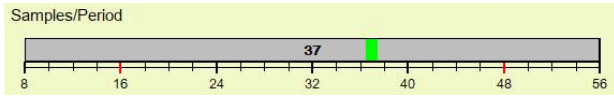

Figure 61: **Samples/Period** bar graph

The bar graph shows the current number of samples per signal period.

- Optimum value:** 32 samples per signal period
- Recommended range:** 16 to 48 samples per signal period

You can see from the color and position of the display element whether the current value is within the recommended range:

Color	Description
Green	The value is within the recommended range
Red	The value is below or above the recommended range

i If the values fall below or significantly exceed the recommended values (from 1,000 sampling points per signal period), the signal deviations cannot be calculated anymore or not with sufficient accuracy.

i High values for the sampling rate or the number of periods can result in long processing times. Use the following formula to assess the amount of data generated during recording:
File size [bytes] = Sampling rate x Recording time x 12 bytes
 Example:
 Sampling rate = 1,000 [kS/s]
 Recording time = 100 [s]
 File size [bytes] = 1,000 x 1,000 x 12 bytes = approx. 1.2 GB

Encoder characteristics



Figure 62: Position display and frequency display

Display	Description
Position [increments]	Current count of the position display Unit: increments
Freq	Input frequency Unit: kHz

Sampling rate

The value in the **Sampling rate** field defines the clock rate at which the analog signals are measured and converted.

Unit: Kilosamples per second (kS/s)
 1 kS/s = 1,000 signal conversions per second

Default setting: 100 kS/s

Setting range: 1 ... 1,800 kS/s

i The optimum sampling rate depends on the signal frequency (see **Freq** value in the **Encoder characteristics** section). The signal frequency increases with the traversing speed or shaft speed of the encoder.

Recommended value: **Sampling rate = 32 · maximum signal frequency**

If the sampling rate is too low, the original signal will be distorted:

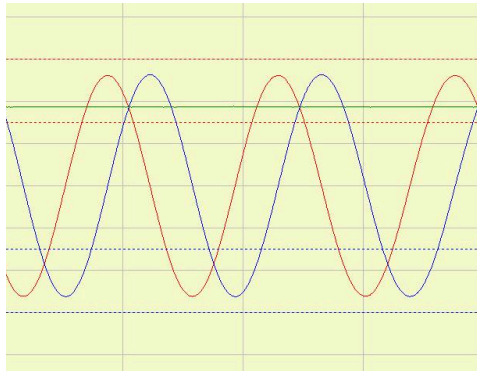

Sufficiently high sampling rate with correct signal shape

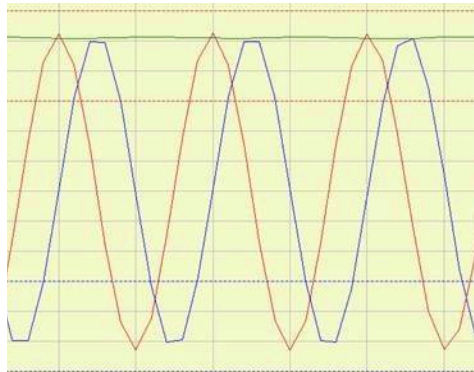

Sampling rate too low with falsified signal shape; correct evaluation is not possible

i When you exit the **Recording** function, the **sampling rate** is reset to default.

Recording to:



Recording to: Position positiv Position negative Number of signal periods

Figure 63: Position display and frequency display

The selection in the **Recording to:** section determines the point at which the recording will end automatically.

Options	Description
Position positive	The input field to the right defines a position in positive direction. Recording ends as soon as the position is reached.
Position negative	The input field to the right defines a position in negative direction. Recording ends as soon as the position is reached.
Number of signal periods	The input field to the right defines the number of signal periods to be recorded. Recording ends as soon as the number is reached, irrespective of the traverse direction. Changes of direction are permitted.

Operating elements

Operating element	Function
Clear counter	Sets the Position [increments] counter to zero
Reset counter + start	Sets the Position [increments] counter to zero and starts the measurement
Start	Starts the measurement from the current value of the Position [increments] counter
Stop	Stops the measurement
Icon	Function
	Stop the measurement Interrupts the measurement and shows the last measured values in diagrams and displays
	Open file Opens the dialog for reloading saved records from a DAT file

9.3.3 Recording and analyzing signal periods



- ▶ Double-click **Recording** in the function menu

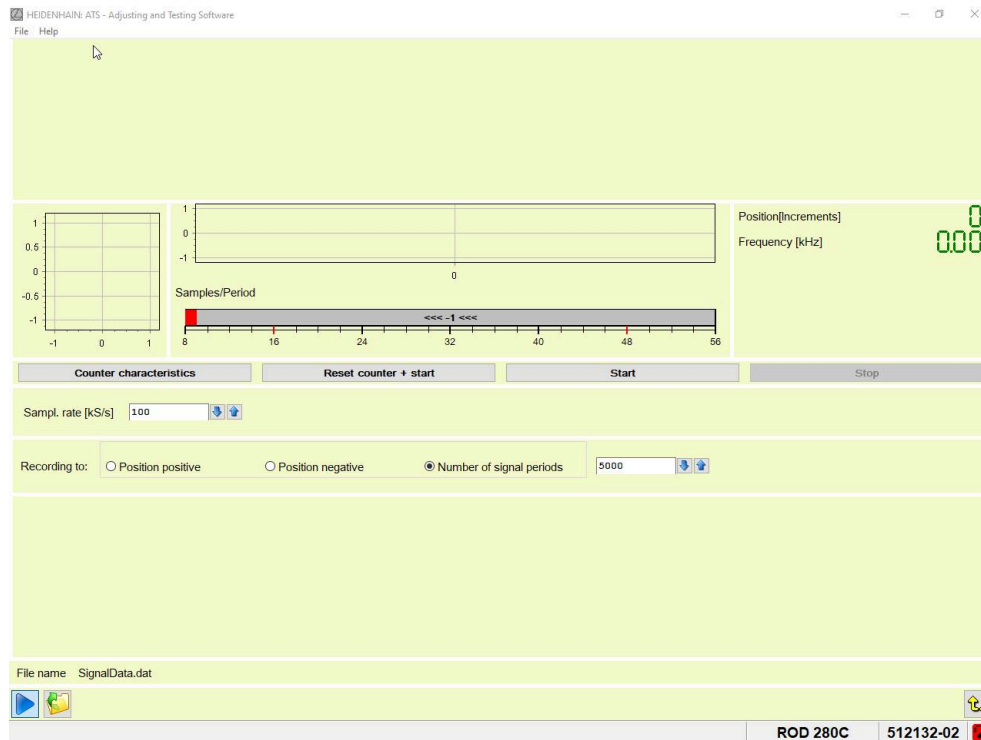

Figure 64: **Recording** function

- ▶ Enter the desired value in the **Sampling rate** field
- ▶ Make the desired selection in the **Recording to** field
- ▶ Click **Start**
- > The values are recorded
- ▶ Traverse the desired measuring range; observe the recommended number of samples
- > The signal periods are recorded at the specified sampling rate
- > Recording ends automatically as soon as the specified number of signal periods has been reached
- or
- ▶ Click **Stop** to stop the measurement manually
- > The result of the recording is displayed

9.3.4 Display of measurement results

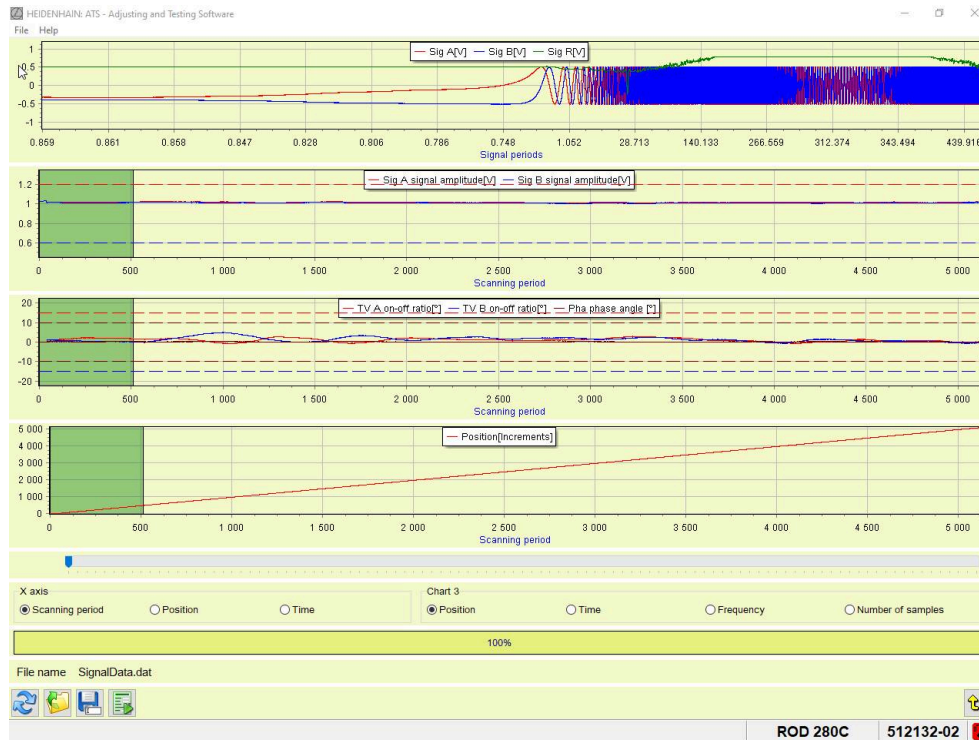

Figure 65: **Recording** function with measurement results

Diagram 1

Diagram 1 shows a section of the recorded signal periods. This section corresponds to the area marked in green in the diagrams 2, 3, and 4.

Depiction	Description
X axis	<p>Depending on the option selected in the X Axis section:</p> <ul style="list-style-type: none"> ■ Scanning period (number of signal periods) If the encoder is in motion, the sampling period equals the number of signal periods. If the encoder is at a standstill: The signal periods are adjusted such that the standstill periods of the encoder can be displayed consistently in the diagrams. Since the values for the signal periods or the position do not change when the encoder is at a standstill, an additional signal period is inserted after 1,000 samples (see Sampling rate). The sum of the actual signal periods of the encoder and the inserted signal periods is referred to as the sampling period. The inserted signal periods are not counted for the recording, but only the actual signal periods of the encoder. ■ Position (increments) ■ Time (unit: seconds)
Y axis	<p>Signal amplitude Unit: volts or microamperes (depending on the encoder)</p>
Red	Signal A
Blue	Signal B
Green	Reference signal

Optimum condition: The amplitudes are symmetrical to the X axis.

Diagram 2

Diagram 2 shows the signal amplitude of all recorded signal periods.

Depiction	Description
X axis	Depending on the option selected in the X Axis section: <ul style="list-style-type: none"> ■ Sampling period (number of signal periods, see "Diagram 1", Page 144) ■ Position (increments) ■ Time (unit: seconds)
Y axis	Signal amplitude Unit: volts or microamperes (depending on the encoder)
Red	Signal A
Blue	Signal B
Dashed lines	Tolerance limits (in the color of the associated curve)

Optimum condition: The amplitudes are at the nominal value or in the tolerance range (dashed lines).

Diagram 3

Diagram 3 shows the on-off ratio and the phase shift all recorded signal periods.

Depiction	Description
X axis	Depending on the option selected in the X Axis section: <ul style="list-style-type: none"> ■ Sampling period (number of signal periods, see "Diagram 1", Page 144)) ■ Position (increments) ■ Time (unit: seconds)
Y axis	Measurement error Unit: degrees
Red	On-to-off ratio of signal A
Blue	On-to-off ratio of signal B
Brown	Phase shift of signals A and B
Dashed lines	Tolerance limits (in the color of the associated curve)

Optimum condition: The values are symmetrical around the zero line or within the tolerance range (dashed lines).





Diagram 4

Diagram 4 can be configured individually.

Depiction	Description
X axis	Depending on the option selected in the X Axis section: <ul style="list-style-type: none"> ■ Sampling period (number of signal periods, see "Diagram 1", Page 144)) ■ Position (increments) ■ Time (unit: seconds)
Y axis	Depending on the option selected in the Chart 3 section: <ul style="list-style-type: none"> ■ Position (increments) ■ Time (unit: seconds) ■ Frequency (unit: kilohertz) ■ Number of samples
Red	Depending on the option selected in the Chart 3 section: <ul style="list-style-type: none"> ■ Position ■ Time ■ Frequency ■ Number of samples
Dashed lines Displayed if the Samples option is selected in the Chart 3 section	Recommended number of samples: <ul style="list-style-type: none"> ■ Green: recommended range ■ Red: functional limit of the Adjusting and Testing Software <div style="border: 1px solid black; padding: 5px; margin-top: 10px;"> <p>i If the function limits are exceeded, the correct calculation of the signal deviations is not guaranteed.</p> </div>

i If the **Signal periods** or **Position** option is selected in the **X Axis** section, the diagrams for the encoder standstill periods show constant values. This allows for a consistent representation throughout all diagrams.

Operating elements

Symbol	Function
	Reset diagram view Resets all diagrams to default view
	Open file Opens the dialog for reloading saved records from a DAT file
	Save file Opens the dialog for saving records to a DAT file
	Export data Opens the dialog for exporting records to a TXT file

9.3.5 Adjusting the diagram view

Configuring the X axis

- ▶ To change the reference of the X axis, select the desired option in the **X Axis** field
 - **Sampling period**
 - **Position**
 - **Time**

Configuring the Y axis of diagram 4

- ▶ To change the reference of the Y axis of diagram 4, select the desired option in the **Chart 3** field
 - **Position**
 - **Time**
 - **Frequency**
 - **Number of samples**

Navigating through recorded data

Use the slider to navigate through the recorded data.



- ▶ Hold the mouse button and drag the slider to the desired position
- > Diagram 1 shows the selected detail of the recorded data
- > In the diagrams 2, 3, and 4, the blue section is moved to the selected position



You can save and print the active diagram.

Further information: "Adjusting, exporting and printing diagrams", Page 48



To examine a section more closely, you can zoom in on the diagram view.

Further information: "Magnifying the diagram view", Page 48



- ▶ Click **Reset diagram view** in the control bar to restore the default view
- > The blue section is shifted left to the beginning
- > Zooming is reset

9.3.6 Saving recorded data to a file

The Adjusting and Testing Software saves the recorded data in the file "SignalData.dat".

Path: C: ► Users ► ... ► AppData ► Roaming ► HEIDENHAIN ► ATS

When you make a new recording, the file contents are overwritten. If you want to preserve the recorded data permanently, you can save the data under a different file name.



- Click **Save file** in the control bar
- Select the desired storage location in the dialog
- Enter the desired file name
- Click **Save**
- The file is saved



You can reload recorded data in DAT format in the Adjusting and Testing Software.

9.3.7 Loading recorded data from a file

Preconditions: The recorded data are available in a DAT file.



- Click **Open file** in the control bar
- Select the storage location in the dialog
- Click **Open**
- The diagrams show the recorded data from the file

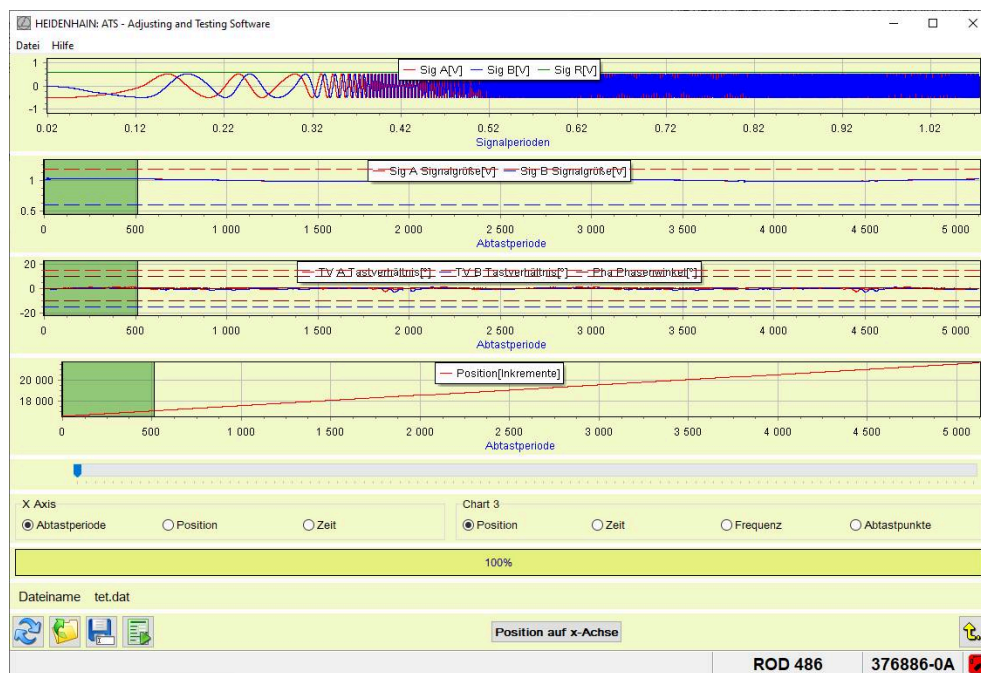



Figure 66: Recorded data loaded from a file



The Adjusting and Testing Software displays the name of the called file below the diagrams.

9.3.8 Exporting recorded data

For further processing in other programs, you can export the recorded data to a TXT file.

 It is not possible to reload the recorded data from a TXT to the Adjusting and Testing Software.



- ▶ Click **Export file** in the control bar
- ▶ Select the desired storage location in the dialog
- ▶ Enter the desired file name
- ▶ Click **Save**
- > The file is saved

 The sampling rate and the column designations of the measured values are also indicated in the two header lines of the TXT file,

9.4 Checking voltage supply

9.4.1 Voltage display function

The **Voltage display** function shows the measured values and status of the voltage supply. The display depends on the operating mode of the testing device.

Operating mode of the testing device	Displayed voltage values
Encoder diagnostics	Encoder powered by the PWM
Monitoring operation with signal adapter	Signal adapter powered by the PWM
Monitoring operation without signal adapter	Encoder powered by the subsequent electronics



► Double-click **Voltage display** in the function menu

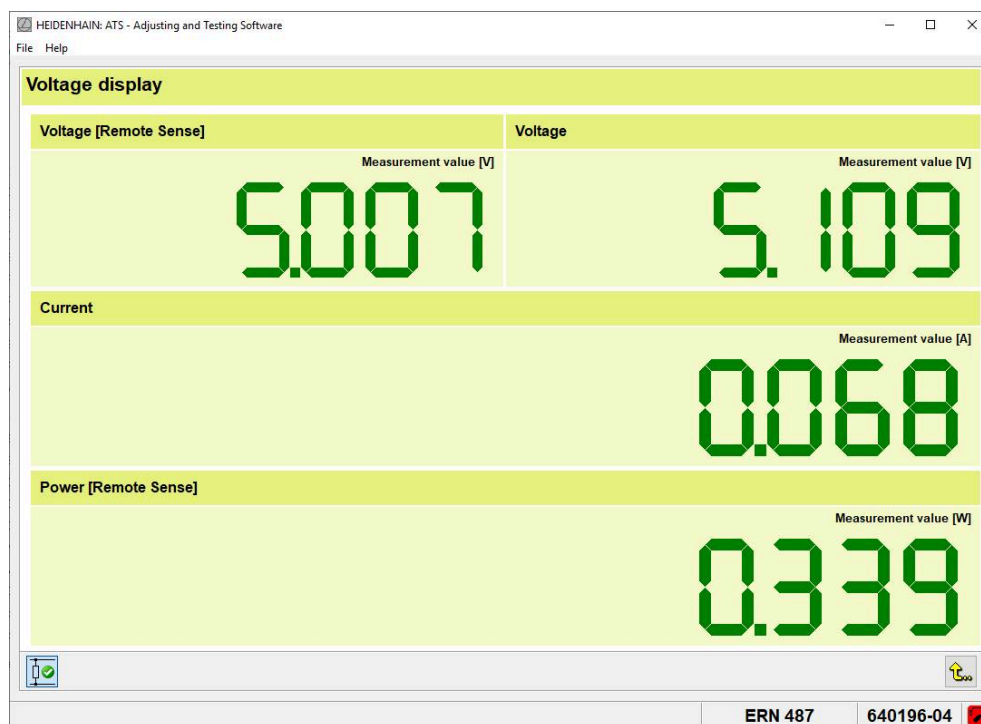

Figure 67: **Voltage display** function

Display	Description
Voltage [Remote Sense]	Operating voltage at the encoder Voltage drops on the encoder supply lines are taken into account. [Remote Sense] : Indicates that voltage readjustment is active
Voltage	Voltage output by the PWM or the downstream electronics
Current	Current consumption of the encoder or the signal adapter <div style="border: 1px solid black; padding: 5px; margin-top: 10px;">i If the encoder does not consume any current, the measured value is displayed in red.</div>
Power [Remote Sense]	Power consumption of the encoder [Remote Sense] : Indicates that voltage readjustment is active

Operating elements

Icon	Function
	Deactivate terminating resistor Switches the terminating resistor off
	Activate terminating resistor Switches the terminating resistor on

9.4.2 Deactivating the terminating resistor

In the Encoder Diagnostics mode, the terminating resistor is activated by default. You can deactivate the terminating resistor to check whether the current consumption of the encoder corresponds to the technical specifications (e.g., the typical current consumption).

- ▶ Click **Deactivate terminating resistor** in the control bar
- > The operating element indicates that the terminating resistor is inactive
- ▶ Click **Activate terminating resistor** to reactivate the terminating resistor
- > The operating element indicates that the terminating resistor is active

i When you exit the function view, the terminating resistor is automatically reactivated.

i In the monitoring mode, the terminating resistor is inactive and cannot be switched on.

9.5 Displaying and copying encoder information

9.5.1 Encoder information function

With the **Encoder information** function you can view information on the connected encoder and copy it to the clipboard to reuse the texts in other applications.



Some functions of the Adjusting and Testing Software are only available if you connect the encoder through its encoder ID (recommended procedure).



► To call this function, double-click **Encoder information** in the function menu

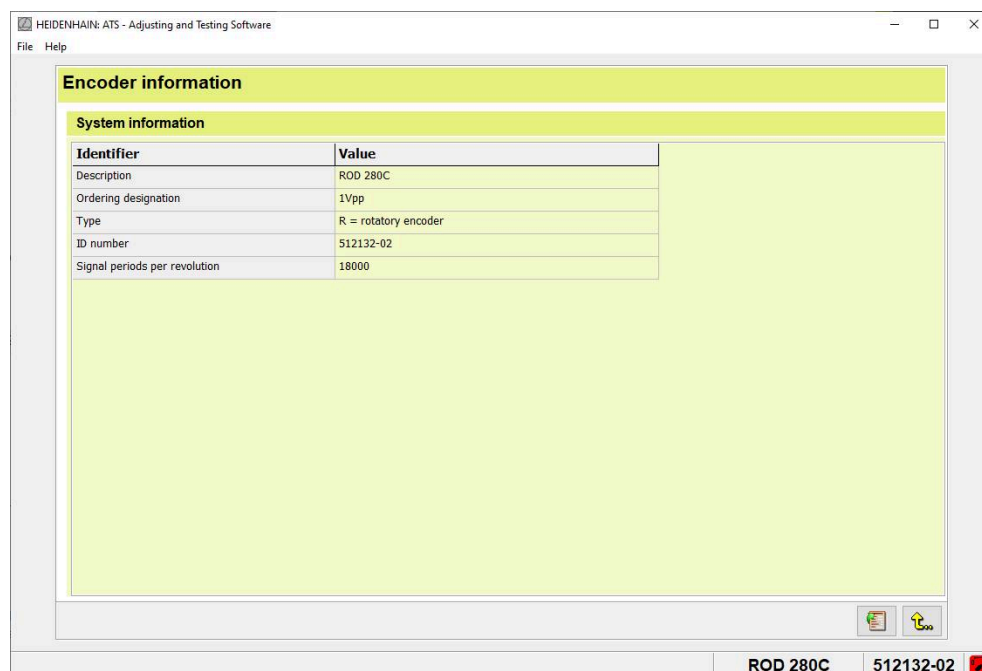

Figure 68: **Encoder information** function

Operating elements

Symbol



Function

Copy encoder information



Copies the displayed encoder information to the clipboard as text

10

**Inspecting encoders
with square-wave
incremental signals**

10.1 Overview

The Adjusting and Testing Software features the following functions for inspecting encoders with square-wave output signals (e.g. HTL or TTL):

Icon	Function	Description
	Incremental signal	Functions for testing incremental signals, if necessary including tolerance check
	Voltage display	Measured values of voltage and current supply
	Encoder information	Display of encoder information

i The displays and the scope of functions of the Adjusting and Testing Software depend on the connected encoder and on the software configuration. When you establish the connection to the encoder, the function menu shows the available functions and operating elements.

i Some encoders also feature the option to switch the sinusoidal incremental signals to the output by means of PWT switch-over ("PWT test function"), so that the encoder mounting can be checked and optimized. For a detailed description of how to examine incremental signals refer to the sections "Analog view", Page 94 and "PWT view", Page 126.

The 11 μ App signals of the PWT test function are designed exclusively for HEIDENHAIN inspection and testing devices. As regards the reference mark signal, square-wave signals with a larger usable component (max. 16 μ App) are also possible here. Please refer to the encoder documentation.

i The views of the **Incremental signal** function have been revised regarding the display layout. Since the graphics have been changed only slightly and the functionality basically remains the same, the screenshots in the documentation will be updated only for significant changes.

10.2 Checking incremental signals

10.2.1 Incremental signal function

Depending on the connected encoder, the **Incremental signal** function includes the following displays:

- **Level:** Examine incremental signals
- **Logic:** Record and analyze incremental signals
- **Counter:** Test counting and reference functions
- **Protocol:** Create logs
- **Note:** Display information on the current measurement

Additionally for encoders that switch the analog incremental signals to the output via PWT switch-over:

- **Analog:** Examine incremental signals
- **PWT:** Examine incremental signals using bar displays

 Some encoders also feature the option to switch the sinusoidal incremental signals to the output by means of PWT switch-over, so that the encoder mounting can be checked and optimized. For a detailed description of how to examine incremental signals refer to the sections "Analog view" and "PWT view".

 Some functions of the Adjusting and Testing Software are only available if you connect the encoder through its encoder ID (recommended procedure).



- ▶ To call this function, double-click **Incremental signal** in the function menu
- > The Adjusting and Testing Software displays the **Level** view

10.2.2 Level view

The **Level** view allows you to check the levels of the following signals:

- Incremental signals and inverted incremental signals
- Reference signal and inverted reference signal
- Fault-detection signal

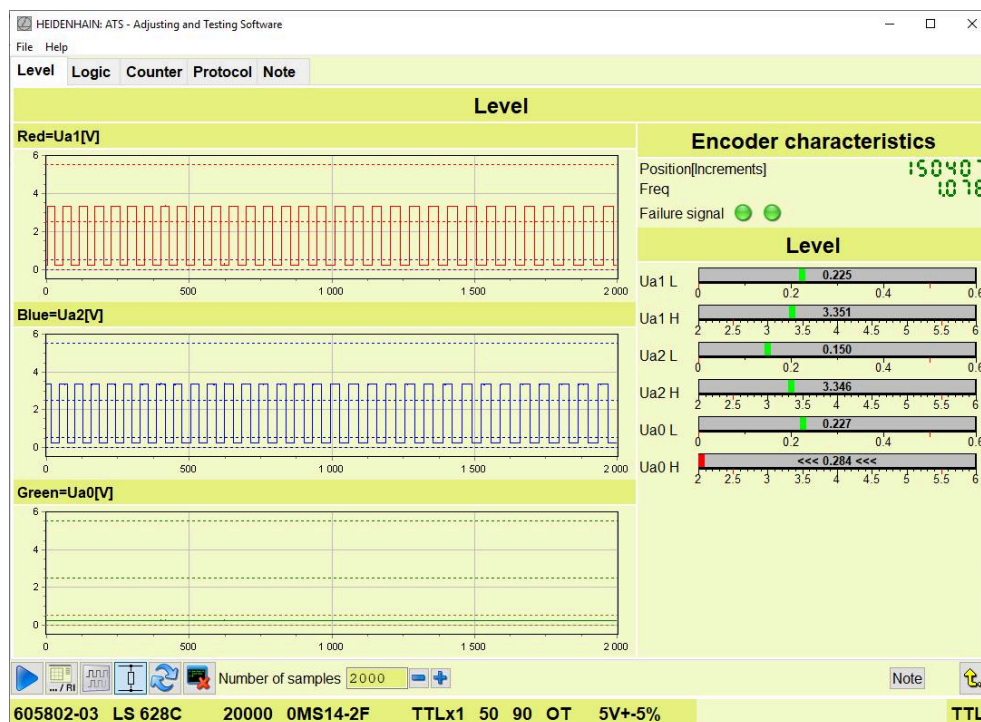

Figure 69: **Level** view of the **Incremental signal** function

Diagrams

The diagrams show the signal levels.

Depiction	Description
X axis	Number of samples
Y axis	Signal amplitude Unit: volts
Red curve	Incremental signal Ua1
Blue curve	Incremental signal Ua2
Green curve	Reference signal Ua0
Dashed lines	Tolerance limits

Encoder characteristics section

Display	Description
Position [increments]	Count value of the position display Unit: Increments
Freq	Input frequency Unit: Kilohertz
Failure signal	Status displays of signal monitoring <ul style="list-style-type: none"> Green: High level of UaS fault-detection signal Red: Low level of UaS fault-detection signal The left status display shows the current status. When the fault-detection signal is at low level, the status display turns red for about 5 seconds. The right status display shows the overall status of the measurement. When the fault-detection signal is at low level, the status display is permanently red.

Level display

When the encoder is traversed, the Adjusting and Testing Software captures the high levels (H) and the low levels (L) of signal and inverted signal. The bars show the measured values and the results of the tolerance check.

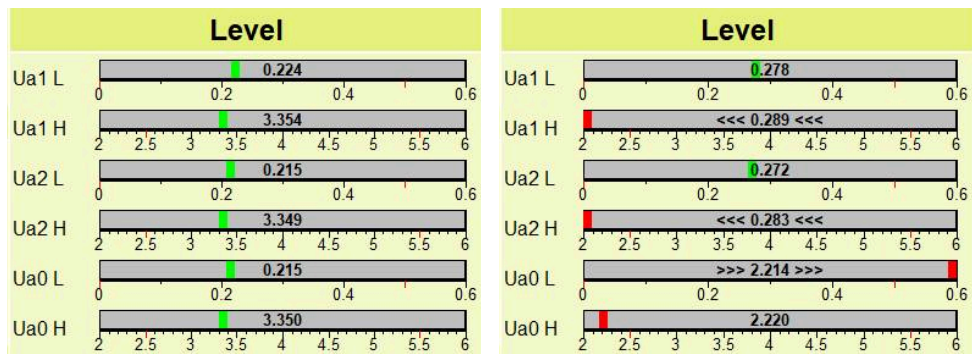

Measured values are within tolerance

Several measured values are outside the tolerance limits

Depiction	Description
	The indicator shows the measured value. The color of the indicator shows the result of the tolerance check: <ul style="list-style-type: none"> Green: Measured value is within the tolerance range Red: Measured value is outside the tolerance range
	The red markings mark the tolerance limits.
<< >>	The arrow symbols indicate that the measured value is beyond the scale. The direction of the arrow shows the direction where the measured value lies.



The Adjusting and Testing Software captures the signal levels, but does not evaluate the differences in the levels. The shown tolerances are HEIDENHAIN standard values! In certain cases, the tolerance limits of the encoder may differ from the tolerance limits displayed.

Note the tolerances specified in the documentation of the encoder.



The following information refers to the signal diagrams in the document **Interfaces of HEIDENHAIN Encoders**.

Further information: "Opening documentation", Page 47

Display	Description
Ua1 L	Low level of incremental signal Ua1 Unit: volts
Ua1 H	High level of incremental signal Ua1 Unit: volts
Ua2 L	Low level of incremental signal Ua2 Unit: volts
Ua2 H	High level of incremental signal Ua2 Unit: volts
Ua0 L	Low level of reference signal Ua0 Unit: volts
Ua0 H	High level of reference signal Ua0 Unit: volts

Operating elements

Icon	Function
	Stop the measurement Interrupts the measurement and shows the last measured values in the diagram and the displays
	Measurement stopped Indicates that the measurement has been stopped
	Evaluate the reference signal Shows the Trigger status display and switches the diagrams to reference pulse detection
	Switch the signal display Switches to the measured values of the inverted signals
	Reset status displays Resets the Failure signal status displays to green
	Deactivate the terminating resistor Switches the terminating resistor off
	Transfer data to Protocol view Transfers the displayed data to the Protocol screen

Icon	Function
	<p>Show notes</p> <p>Indicates that there is new information on the current measurement</p>

Number of samples

The value in the **Number of samples** field determines how many measured values are displayed in the diagram.

Default setting: 2,000
 Setting range: 2,000 ... 100,000

 The optimum value depends on the signal frequency (see **Freq** value in the **Encoder characteristics** section). The signal frequency increases with the traversing speed or shaft speed of the encoder. The higher the signal frequency, the lower a value you should select in the **Number of samples** field. For level evaluation, a maximum of ten signal periods should be shown in the diagram.

 When you exit the **Incremental signal** function, the value in the **Number of samples** field is reset to default.

10.2.3 Checking incremental signals (Level view)

To detect signal interruptions or short-circuits, check both the incremental signals and the inverted incremental signals, each with the terminating resistor active and inactive.

 A warning symbol appears in the control bar when there are notes. Delete existing notes before you start the examination.

Further information: "Displaying and deleting notes (Note view)", Page 188

Checking incremental signals



- ▶ Click **Reset status displays** in the control bar to reset the signal monitoring status
- The **Failure signal** status displays are green
- ▶ Enter the desired value in the **Number of samples** field
- ▶ Traverse the entire measuring range
- The diagram and the bar display show the measured values and tolerances of the incremental signals

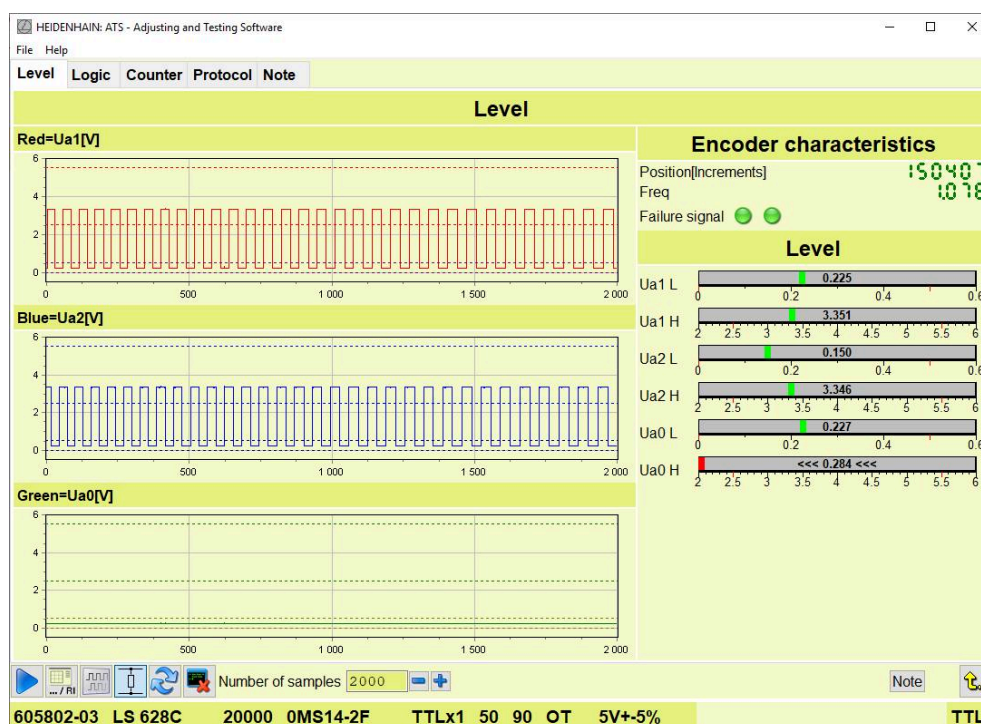

Figure 70: Level view of the Incremental signal function



You can save and print the active diagram.

Further information: "Adjusting, exporting and printing diagrams", Page 48



To examine a section more closely, you can zoom in on the diagram view.

Further information: "Magnifying the diagram view", Page 48



Repeat the examination with the terminating resistor inactive.

Further information: "Deactivating the terminating resistor", Page 161

Checking inverted incremental signals



- ▶ Click **Switch signal display** in the control bar to display the inverted signals
- ▶ Traverse the entire measuring range
- ▶ The diagram and the bar display show the measured values and tolerances of the inverted signals

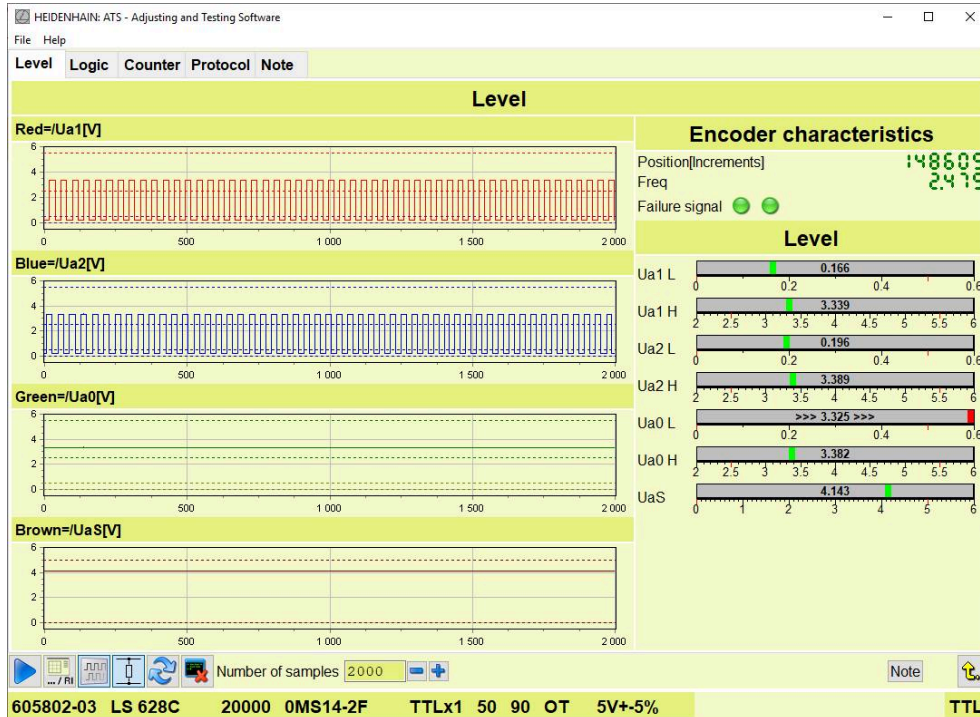
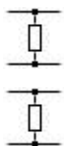

Figure 71: **Level** view when evaluating inverted signals

i The Adjusting and Testing Software displays the fault-detection signal UaS in an additional diagram and an additional bar graph. During fault-free operation the high level is shown. In the event of error the fault-detection signal switches to low level.

i Repeat the examination with the terminating resistor inactive.
Further information: "Deactivating the terminating resistor", Page 161

Deactivating the terminating resistor



- ▶ Click **Deactivate terminating resistor** in the control bar
- ▶ The terminating resistor is deactivated
- ▶ Click the operating element again to reactivate the terminating resistor

i When you exit the function view, the terminating resistor is automatically reactivated.

i In the monitoring mode, the terminating resistor is inactive and cannot be switched on.

Stopping the measurement

You can stop the measurement to analyze a specific point or take a screenshot.



- ▶ Click **Stop measurement** in the control bar
- > The diagram and the displays hold the last measured values



- ▶ Click the operating element again to continue the measurement

Transferring data to the Protocol view

You can transfer the displayed data to the **Protocol** view and save them later on as a log file (PDF format).



The data are temporarily retained in the **Protocol** view until you exit the **Incremental signal** function.



- ▶ To store data temporarily, click on **Transfer data to the Protocol view**
- > The Adjusting and Testing Software displays the **Protocol** view with the buffered values

Further information: "Protocol view", Page 134

10.2.4 Checking the reference signal (Level view)

The **Level** view allows you to check the levels of the reference signal.



- ▶ Click **Evaluate reference signal** in the control bar
- The **Reference trigger** status display is shown
- ▶ Enter the desired value in the **Number of samples** field
- ▶ Traverse the reference mark
- The diagram **Ua0** shows the reference pulse
- The **Reference signal** section shows the values of the traversed reference mark
- ▶ Traverse further reference marks, if required
- The diagrams are refreshed each time a reference mark is traversed

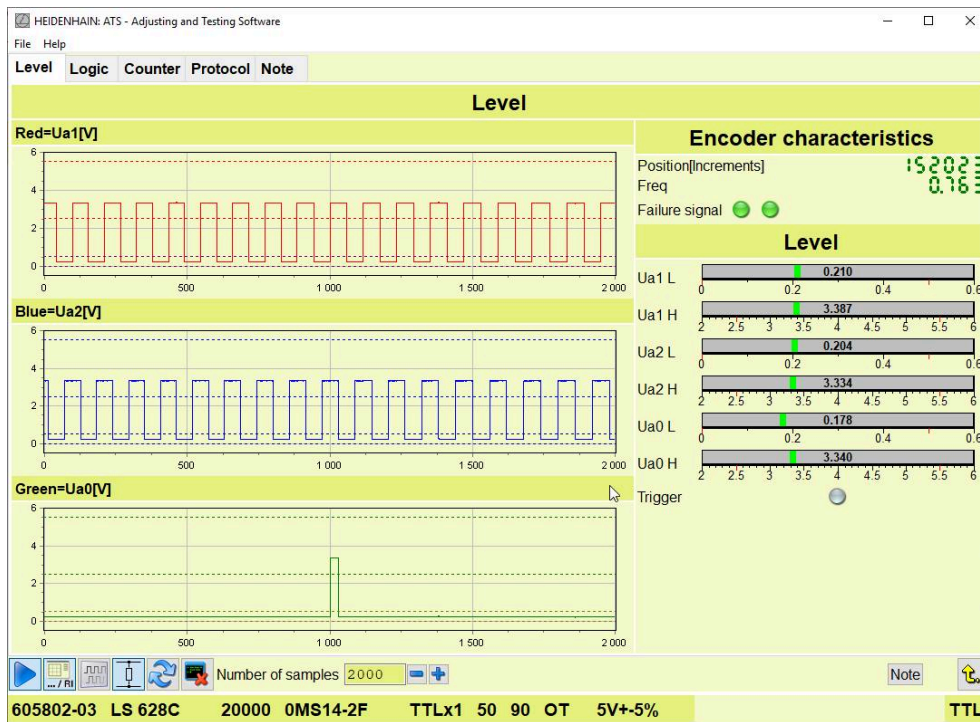

Figure 72: Incremental signal function when evaluating the reference signal

Depiction	Description
X axis (t)	Number of samples
Y axis	Signal amplitude Unit: volts
Red curve	Incremental signal Ua1
Blue curve	Incremental signal Ua2
Green curve	Reference signal Ua0
Dashed lines in the color of the signals	Tolerance limits of the respective signal

Trigger status display

Depiction	Description
Trigger	<p>Status display of reference mark detection</p> <ul style="list-style-type: none"> ■ Gray: no reference mark was detected ■ Green: a reference mark was detected <p>When a reference mark was detected, the status display changes back to gray color after 0.5 seconds. If several reference marks follow each other, the status display may be permanently green.</p>



You can transfer the displayed data to the **Protocol** screen and save them later on as a log file (PDF format).

Further information: "Transferring data to the Protocol view", Page 108

10.2.5 Logic view

In the **Logic** view, you can perform a logic analysis and check the signal quality and the position of the reference marks.

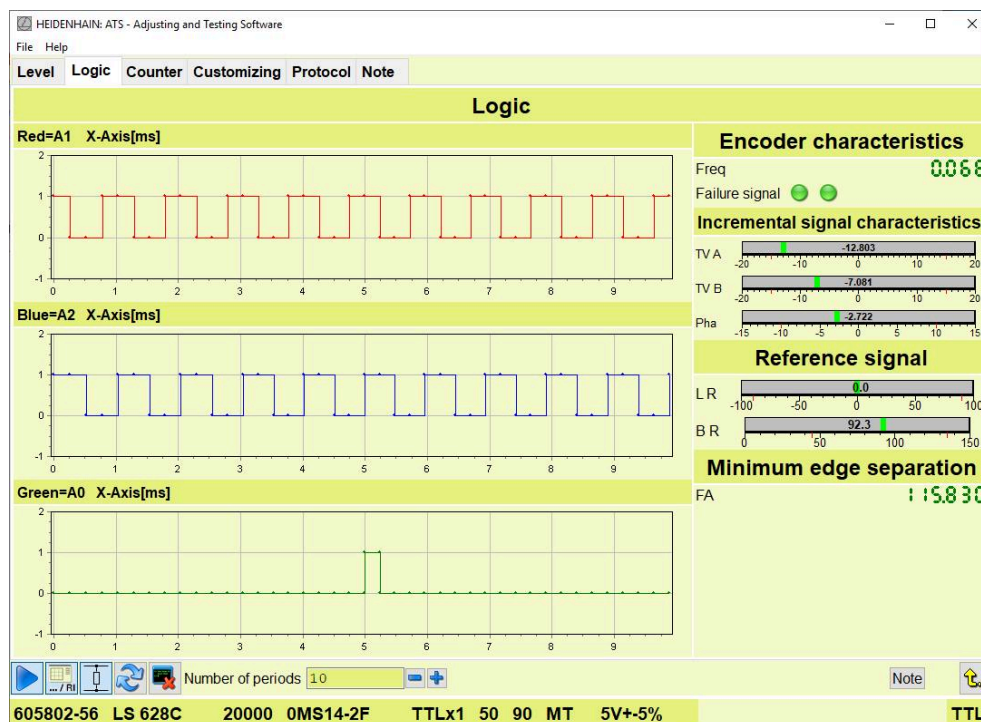

Figure 73: **Logic** view of the **Incremental signal** function



In the **Logic** function, the measured values are recorded at a sampling rate of 200 MS/s.

Diagrams

The diagrams show the signal levels.

Depiction	Description
X axis	Time Unit: milliseconds
Y axis	Level <ul style="list-style-type: none"> ■ 1= high level ■ 0= low level
Red curve	Incremental signal Ua1
Blue curve	Incremental signal Ua2
Green curve	Reference signal Ua0

Encoder characteristics section

Display	Description
Position [increments]	Count value of the position display Unit: Increments
Freq	Input frequency Unit: kilohertz
Failure signal	Status displays of signal monitoring <ul style="list-style-type: none"> ■ Green: High level of UaS fault-detection signal ■ Red: Low level of UaS fault-detection signal The left status display shows the current status. When the fault-detection signal is at low level, the status display turns red for about 5 seconds. The right status display shows the overall status of the measurement. When the fault-detection signal is at low level, the status display is permanently red.

Characteristics of the incremental signals section

The bars show the measured values and the results of the tolerance check.

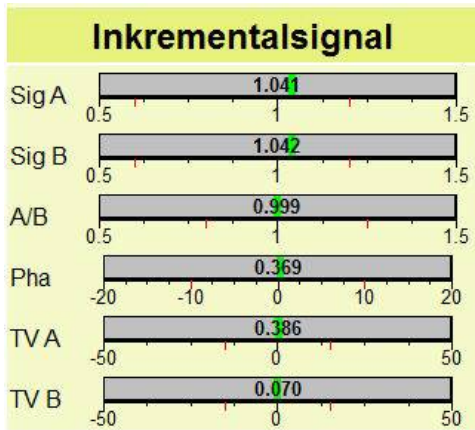

Measured values are within tolerance

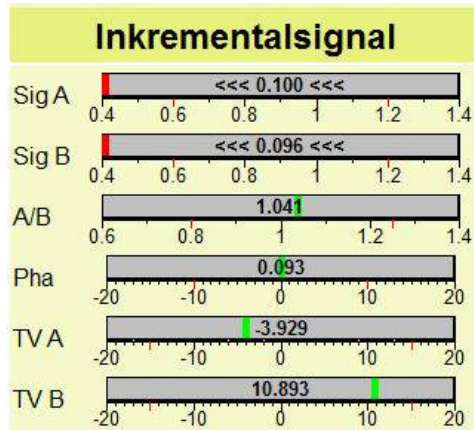

Several measured values are outside the tolerance limits

Depiction**Description**

The indicator shows the measured value.

The color of the indicator shows the result of the tolerance check:

- Green: Measured value is within the tolerance range
- Red: Measured value is outside the tolerance range



The red markings mark the tolerance limits.



The arrow symbols indicate that the measured value is beyond the scale. The direction of the arrow shows the direction where the measured value lies.



The following information refers to the signal diagrams in the document **Interfaces of HEIDENHAIN Encoders**.

Further information: "Opening documentation", Page 47



The following figures illustrate the description using sinusoidal signals. The information is equally valid for square-wave signals.

Display**Description**

Pha

Phase shift of signals A and B

Optimum condition:

Signal A precedes signal B by 90°.

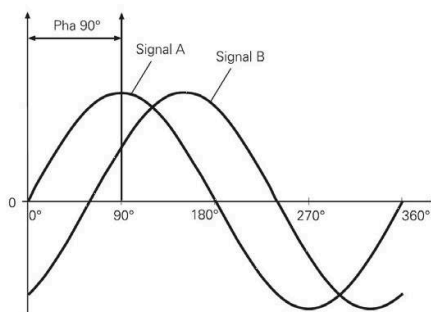

Phase shift = 90°

Phase shift error = 0°

The Adjusting and Testing Software displays the phase shift error—i.e. the deviation from the optimum condition—in degrees.

Calculation: **Pha = |φA + φB| / 2**

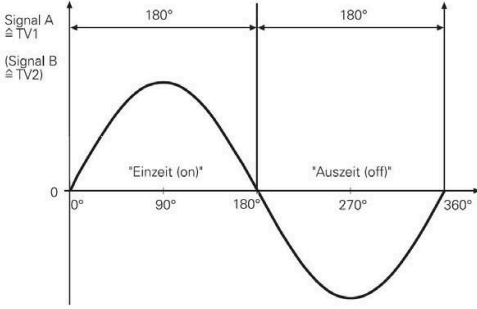
Display	Description
TV A	<p>On-off ratio of signal A</p> <p>The signals are triggered at zero crossover. A signal period consists of the high time plus the low time of the square-wave signal and is subdivided into 360°.</p> <p>Optimum condition: High time and low time of a signal period are equally long.</p>  <p>High time = Low time = 180°</p> <p>On-off ratio error = 0°</p> <p>The Adjusting and Testing Software displays the on-off ratio error—i.e. the deviation from the optimum condition—in degrees.</p> <p>In the documentation, the ratio of high time to low time may also be specified as symmetry deviation (SYM) in radians.</p> <div style="border: 1px solid black; padding: 5px; margin-top: 10px;"> <p>i In contrast to the definition of the symmetry (SYM), the algebraic sign of the deviation is also output. This simplifies application cases, such as mounting an encoder.</p> </div> <p>Calculation:</p> <p>SYM = P - N / 2 · M</p> <p>TV = 2 · 180 / π · sin (2 · SYM)</p>

TV B	<p>On-off ratio of signal B</p> <p>Description see "TV A"</p> <div style="border: 1px solid black; padding: 5px; margin-top: 10px;"> <p>i The measurement results for Pha, TV A and TV B are particularly significant with non-clocked interpolators. In the case of clocked interpolators, the interpolator considerably influences the measurement results.</p> </div>
------	---

Reference signal section

Depiction	Description
LR	Position of the reference pulse Formula: $(K - L) / 2$
BR	Width of the reference pulse Formula: $K + L$







 The measurement results for LR and BR are particularly significant with non-clocked interpolators. In the case of clocked interpolators, the interpolator considerably influences the measurement results.

Minimum edge separation section

Depiction	Description
FA	Minimum edge separation of the overall measurement Unit: microseconds

 The edge separation depends on the frequency of the output signal: The higher the frequency of the output signal, the shorter the edge separation.

Operating elements

Icon	Function
	Start recording Starts recording with the specified number of periods
	Measurement stopped Indicates that the measurement has been stopped
	Hold the reference pulse Freezes the diagram view when reference marks are traversed
	Reset the edge separation Resets the FA counter and restarts determination of the edge separation
	Transfer data to Protocol view Transfers the displayed data to the Protocol screen
	Notes Indicates that there is new information on the current measurement

Number of periods

The value in the **Number of periods** field determines how many signal periods are displayed in the diagram.

Default setting: 10

 When you exit the **Incremental signal** function, the value in the **Number of periods** field is reset to default.

10.2.6 Performing logic analysis (Logic view)



A warning symbol appears in the control bar when there are notes. Delete existing notes before you start the examination.

Further information: "Displaying and deleting notes (Note view)", Page 188



- ▶ Double-click **Incremental signal** in the function menu
- ▶ Click the **Logic** tab to switch to the **Logic** view

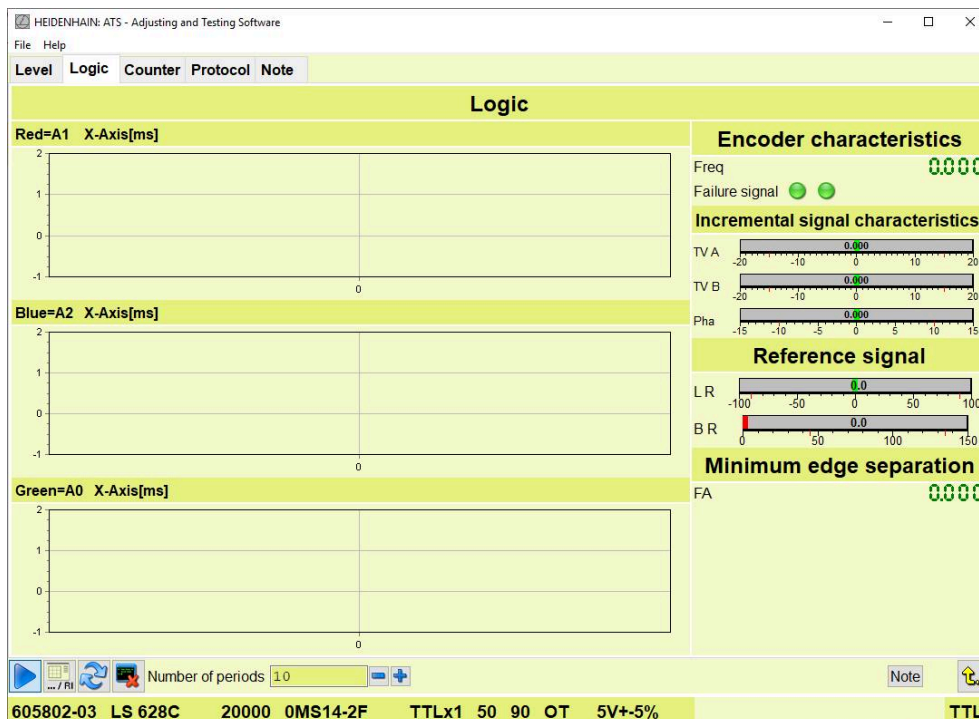
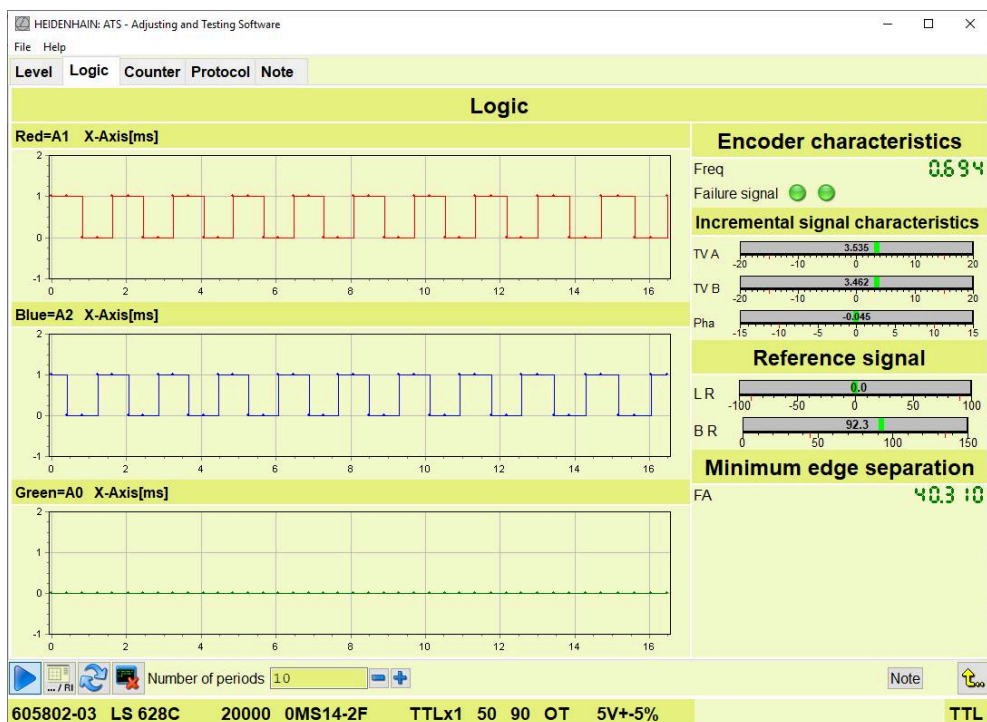

Figure 74: **Logic** view of the **Incremental signal** function

- ▶ Enter the desired value in the **Number of periods** field
- ▶ Traverse the entire measuring range
- ▶ The diagrams and the bar displays show the measured values and tolerances
- ▶ The **FA** counter displays the minimum edge separation

Figure 75: **Logic** view with measured values

You can save and print the active diagram.

Further information: "Adjusting, exporting and printing diagrams", Page 48



To examine a section more closely, you can zoom in on the diagram view.

Further information: "Magnifying the diagram view", Page 48

Checking the reference signal

You can record the reference pulses in the diagram view to check the position of the reference marks. The diagram view is then refreshed each time a reference mark is traversed.



- ▶ Click **Hold the reference pulse** in the control bar
- ▶ Traverse the reference mark
- ▶ The diagram shows the reference pulse
- ▶ The diagram view will be refreshed when the next reference mark is traversed

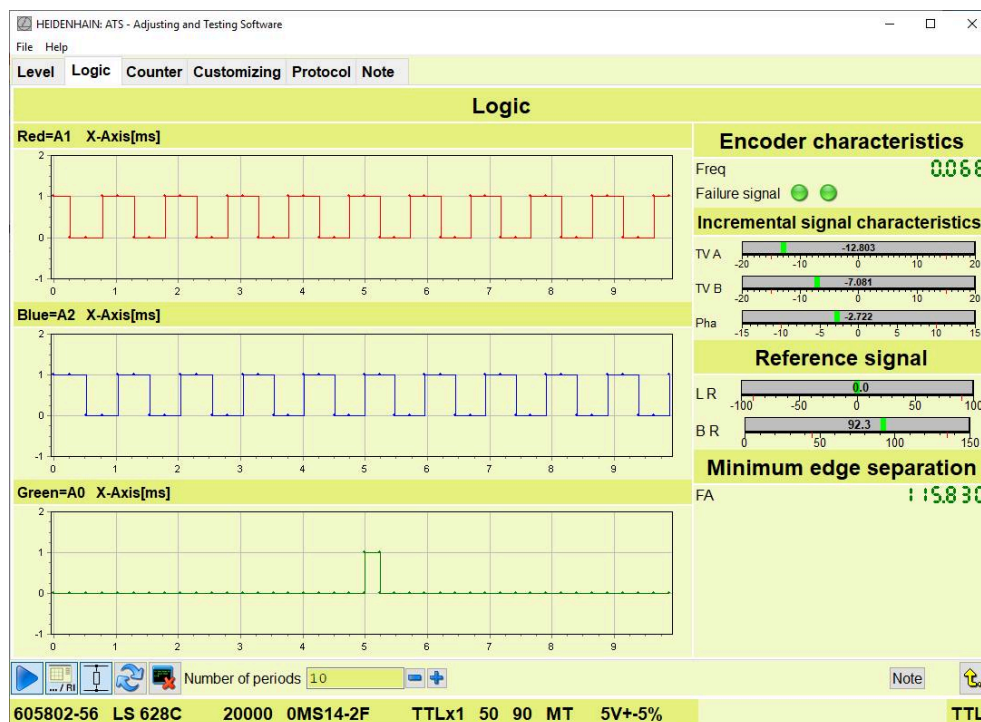

Figure 76: **Logic** view with measured values

Stopping the measurement

You can stop the measurement to analyze a specific point or take a screenshot.



- ▶ Click **Stop measurement** in the control bar
- ▶ The diagram and the displays hold the last measured values
- ▶ Click the operating element again to continue the measurement



You can transfer the displayed data to the **Protocol** screen and save them later on as a log file (PDF format).

Further information: "Transferring data to the Protocol view", Page 108

Resetting the Minimum edge separation counter

To repeat the measurement, you can reset the value of the Minimum edge separation counter.



- ▶ Click **Reset edge separation** in the control bar
- ▶ The **FA** counter displays the value "0"

10.2.7 Counter view

In the **Counter** view, you can check the counting function and the reference function of incremental encoders. The **Counter** view shows the distances between the reference marks as the encoder moves.

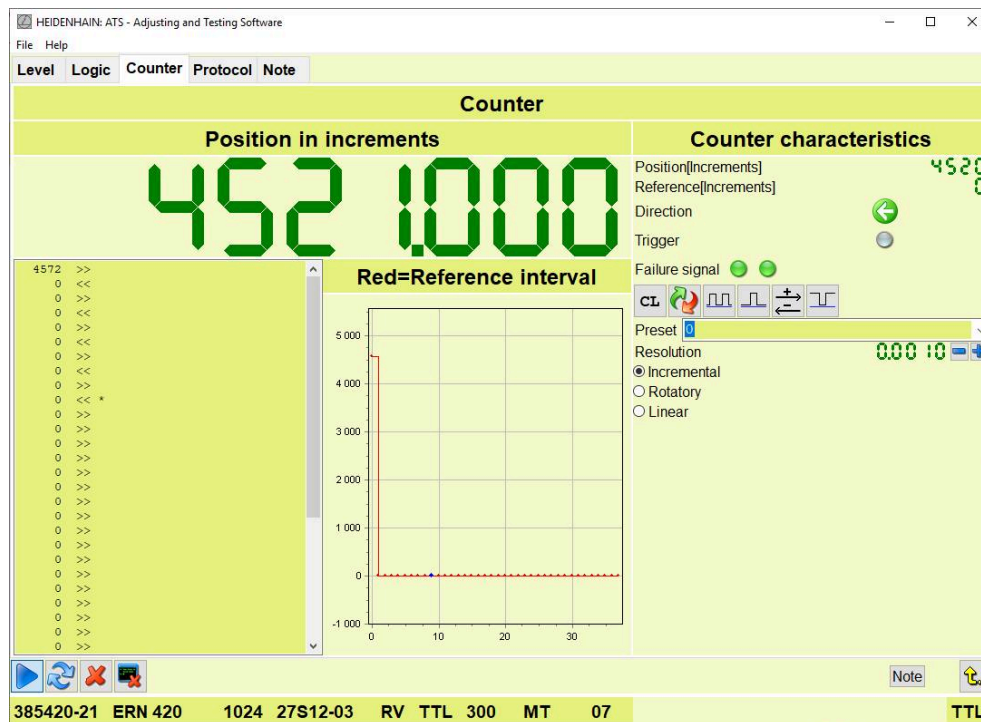

Figure 77: **Counter** view of the **Incremental signal** function

Table

When a reference mark is passed over, the distance to the preceding reference mark is determined and an entry added to the table. The table contains the following information:

- The asterisk marks the count value at the current position
- The arrows show the direction of traverse
- With distance-coded reference marks, the nominal increment is shown in addition to the count values

Bar graph

Depiction	Description
X axis	Number of captured reference marks
Y axis	Number of signal periods
Red	Reference mark spacing
Blue	Current position

Counter section

Display	Description
Position in [unit]	Current count of the incremental counter Unit: Depends on the settings in the Counter characteristics section

Counter characteristics section







Display	Description
Position [increments]	Current count Unit: increments
Reference [increments]	Distance between the two reference marks traversed last Unit: increments
Direction	The arrow shows the traverse direction <ul style="list-style-type: none"> ■ Arrow to the right: positive count value recorded ■ Arrow to the left: negative count value recorded
Trigger	Status display of reference mark detection <ul style="list-style-type: none"> ■ Gray: no reference mark was detected ■ Green: a reference mark was detected <p>When a reference mark was detected, the status display changes back to gray color after 0.5 seconds. If several reference marks follow each other, the status display may be permanently green.</p>
Failure signal	Status display of signal monitoring <ul style="list-style-type: none"> ■ Green: High level of UaS fault-detection signal ■ Red: Low level of UaS fault-detection signal <p>The left status display shows the current status. When the fault-detection signal is at low level, the status display turns red for about 5 seconds.</p> <p>The right status display shows the overall status of the measurement. When the fault-detection signal is at low level, the status display is permanently red.</p>

Settings in the Counter characteristics section

In the **Counter characteristics** section you can adjust the settings for the counter value display **Position in [unit]**. The position value is calculated according to these settings.

Display	Description
Preset	Input field for presetting a count value
Resolution	Counter resolution
<ul style="list-style-type: none"> ■ Incremental ■ Rotatory ■ Linear 	<p>Type of incremental counter</p> <p>The count value is converted into the corresponding unit as per the selection:</p> <ul style="list-style-type: none"> ■ Incremental: Measuring steps ■ Rotatory: Selected unit (see below); Standard setting: Degrees ■ Linear: Micrometers <p>Depending on the selection, the following settings are displayed.</p>
Line count	Input field for the encoder line count per revolution to calculate the count value
<ul style="list-style-type: none"> ■ Degrees ■ Radian measure ■ DMS 	<p>Unit of the incremental counter</p> <p>The value of the incremental counter is converted into the selected unit.</p> <ul style="list-style-type: none"> ■ Degrees ■ Radian measure ■ DMS: Degrees, minutes, seconds
Signal period	Input field for the length of a signal period to calculate the count value

Operating elements

Icon	Function
	<p>Stop the measurement</p> <p>Interrupts the measurement and shows the last measured values in the diagram and the displays</p>
	<p>Measurement stopped</p> <p>Indicates that the measurement has been stopped</p>
	<p>Reset status displays</p> <p>Resets the Failure signal status displays to green</p>
	<p>Delete measured values</p> <p>Deletes the measured values recorded from the table and graphics</p>
	<p>Transfer data to Protocol view</p> <p>Transfers the displayed data to the Protocol view</p>
	<p>Notes</p> <p>Indicates that there is new information on the current measurement</p>

10.2.8 Checking the counting function (Counter view)



A warning symbol appears in the control bar when there are notes. Delete existing notes before you start the examination.

Further information: "Displaying and deleting notes (Note view)", Page 188



- ▶ Double-click **Incremental signal** in the function menu
- ▶ Click the **Counter** tab to switch to the **Counter** view

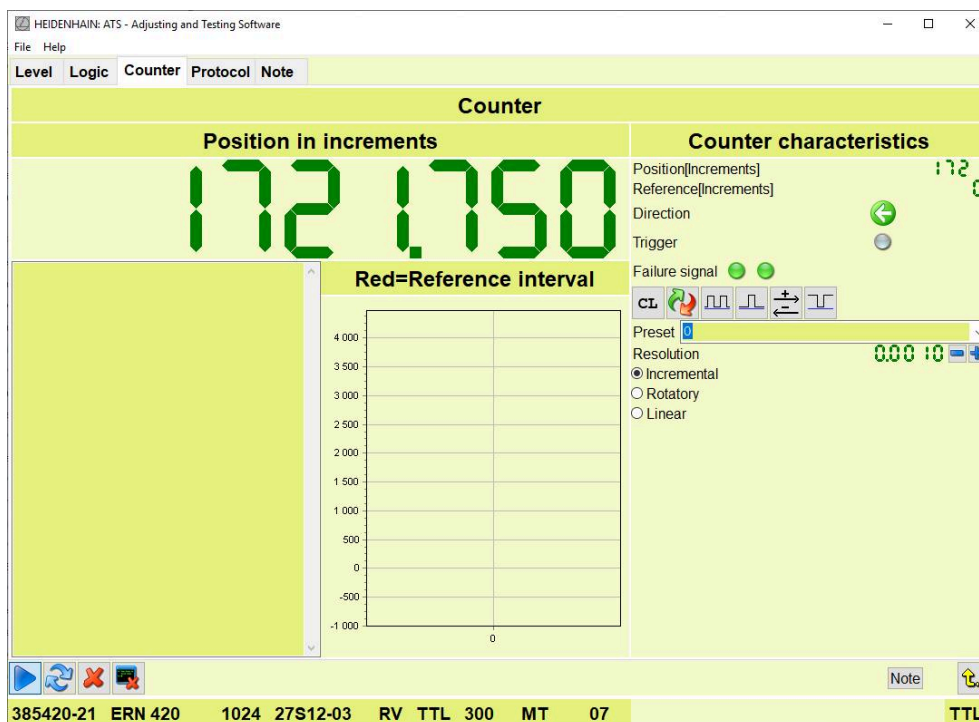

Figure 78: **Counter** view of the **Incremental signal** function



The further procedure depends on the type of reference marks the encoder features.

Procedure with one reference mark

- ▶ Traverse the reference mark
- ▶ Traverse the reference mark in the opposite direction
- ▶ Repeat the procedure several times
- A measured value is added to the table and the diagram each time the reference mark is traversed

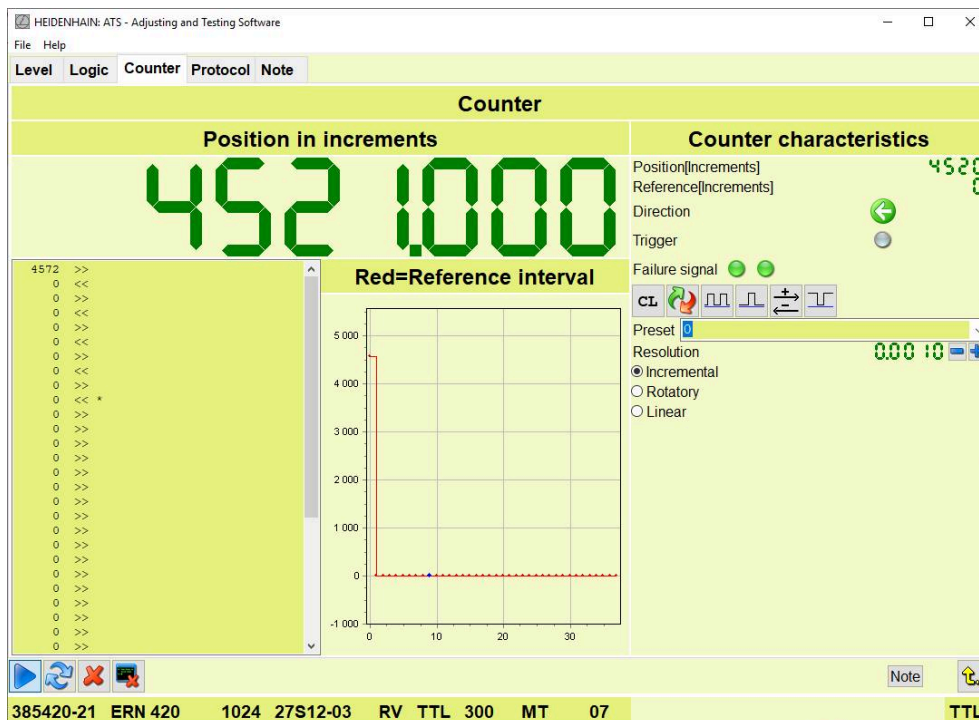

Figure 79: **Counter** view when examining an encoder with one reference mark

i Counter and reference functions are error-free if the distance is "0" each time the reference mark is traversed.

i You can transfer the displayed data to the **Protocol** screen and save them later on as a log file (PDF format).

Further information: "Transferring data to the Protocol view", Page 108

Procedure with multiple reference marks without distance coding

- ▶ Traverse several reference marks
- A measured value is added to the table and the diagram each time a reference mark is traversed
- ▶ Traverse the reference marks in the opposite direction
- When the direction is reversed, the value "0" is added to the table and the diagram

i Counter and reference functions are error-free if the spacing between all reference marks is the same.

i You can transfer the displayed data to the **Protocol** screen and save them later on as a log file (PDF format).

Further information: "Transferring data to the Protocol view", Page 108

Procedure with distance-coded reference marks

When you examine encoders with distance-coded reference marks, the Adjusting and Testing Software first determines the nominal increment.

- ▶ Traverse several reference marks to determine the nominal increment
- ▶ If the traverse path of the encoder is short, you may need to traverse it in both directions repeatedly
- After the Adjusting and Testing Software has determined the nominal increment, the table also includes the nominal increment and the position

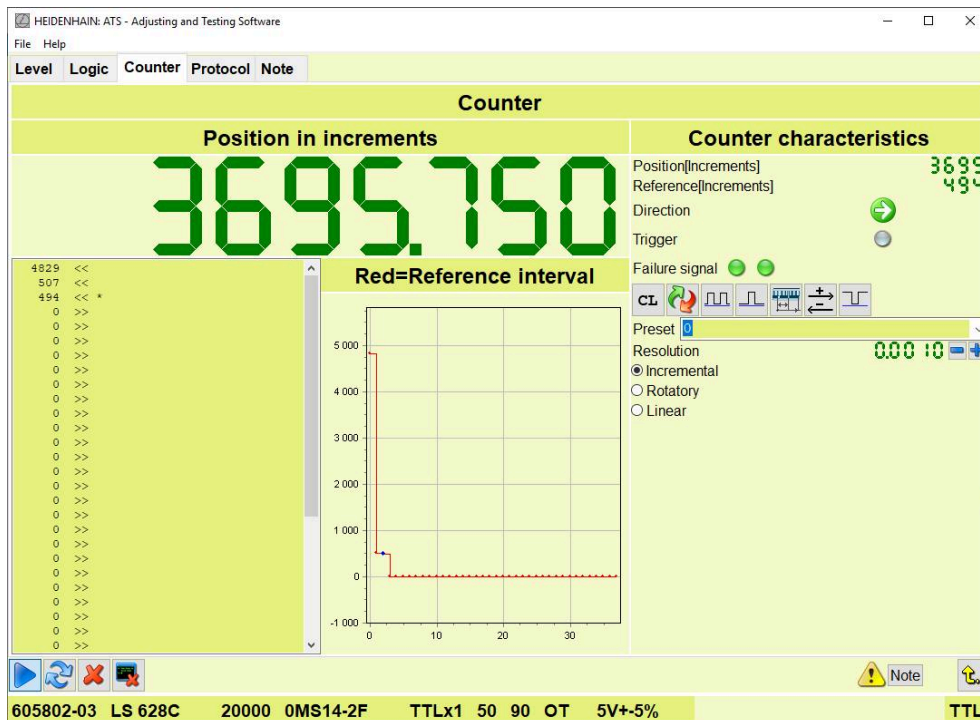

Figure 80: Display during determination of nominal increment

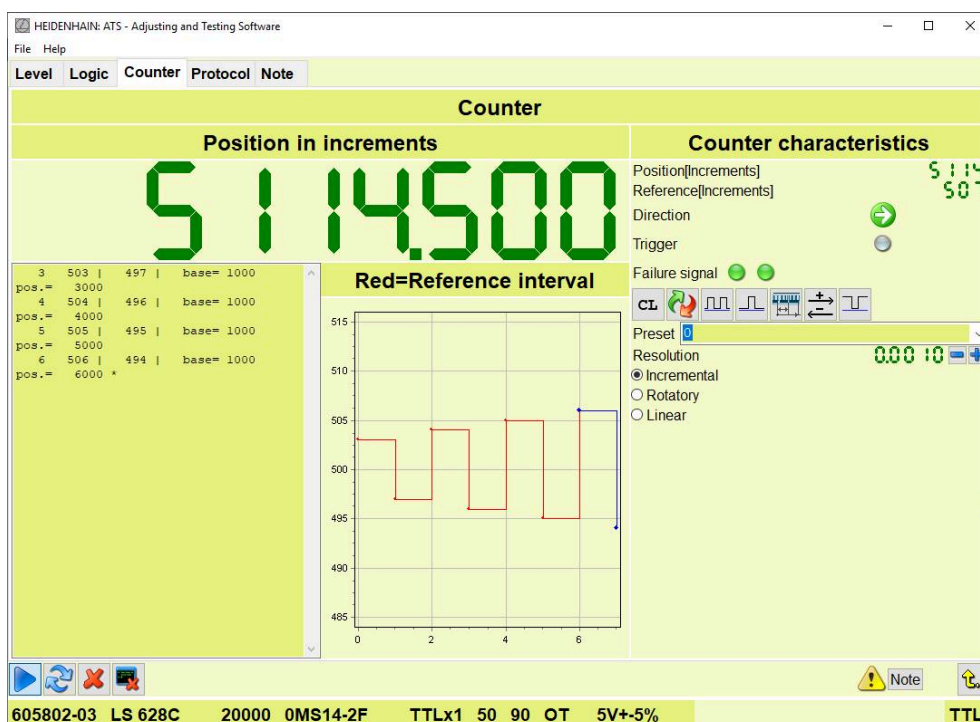

Figure 81: Display after the nominal increment has been determined

Column	Description
1	Reference mark spacing 1
2	Reference mark spacing 2
3	base: Nominal increment
4	pos.: Position determined from distance coding
5	Value "Direction!": Appears if the counting direction determined from the incremental signals differs from the sequence of reference mark spacings 1,2 <ul style="list-style-type: none"> ▶ Traverse the entire measuring range > A measured value is added to the table and the diagram each time a reference mark is traversed ▶ Traverse the reference marks in the opposite direction > When the direction is reversed, the value "0" is added to the table and the diagram

i Counter and reference functions are error-free if the determined distances are the same as the actual distance coding of the encoder. The sum of the values in the columns 1 and 2 must correspond to the nominal increment (value in column 3).

i If the value "Direction!" is shown in the last column, check the counting direction and the encoder wiring.

i Deviations indicate a malfunction or improper mounting of the encoder.

i You can transfer the displayed data to the **Protocol** screen and save them later on as a log file (PDF format).

Further information: "Transferring data to the Protocol view", Page 108

Adjusting the counter display

The counter display can be adjusted in the **Counter characteristics** section.

- ▶ Set the desired counter resolution with the plus and minus buttons
- ▶ Select desired display options:
 - **Incremental**: Count value is displayed in increments
 - **Rotatory**: Count value is displayed in the selected angle unit
 - **Degrees**
 - **Radian measure**
 - **DMS** (degrees, arc minutes, arc seconds)
 - **Linear**: Count value is displayed in micrometers
- ▶ If you select **Rotatory**, enter the line count per encoder revolution in the **Line count** field
- ▶ If you select **Linear**, enter the length of a signal period in micrometers in the **Signal period** field
- ▶ The count value is converted and displayed according to the setting

Presetting the count value

To compare the counter e.g. with the counter of the subsequent electronics, you can preset a certain count value at the current position.



- ▶ Enter the desired position value in the **Preset** field
- ▶ Click **Preset count value** in the control bar
- ▶ The entered count value is adopted as the new position

Clearing the counter

CL

- ▶ Click **Clear counter** in the control bar
- ▶ The counter is set to zero

Clearing the counter with every reference mark



- ▶ To start counting at every reference mark, click **Clear counter with every reference mark** in the control bar
- ▶ The counter is set to zero each time a reference mark is traversed

Clearing the counter and starting with next reference mark



- ▶ Click **Clear counter and start with next reference mark** in the control bar
- ▶ The counter is set to zero and will start counting when the next reference mark is traversed

Inverting the counting direction

The counting direction of some encoders can be configured. You can adapt the counting direction to the encoder in the Adjusting and Testing Software.



- ▶ Click **Invert counting direction** in the control bar to adapt the counting direction
- ▶ The Adjusting and Testing Software inverts the positive or negative counting direction

Clearing the counter and determining the position again

For encoders with distance-coded reference marks, you can set the position and the counter to zero and then determine the position again.



- ▶ Click **Clear counter and determine position again** in the control bar
- The counter is set to zero
- ▶ Traverse several reference marks
- The position is determined again

Evaluating the inverted reference pulse

The reference signal of some encoders is inverted. In order that inverted reference pulses can be detected and correctly evaluated, you need to adapt the evaluation logic of the Adjusting and Testing Software.



- ▶ Click **Evaluate inverted reference pulse** in the control bar
- The Adjusting and Testing Software inverts the evaluation logic

Deleting measured values

For a new examination you can delete the recorded measured values from the table and from the diagram.



- ▶ Click **Delete measured values** in the control bar
- The table and the diagram are reset

10.2.9 Homing – Limit view

The **Homing – Limit** view provides a functional check of limit switching signals.

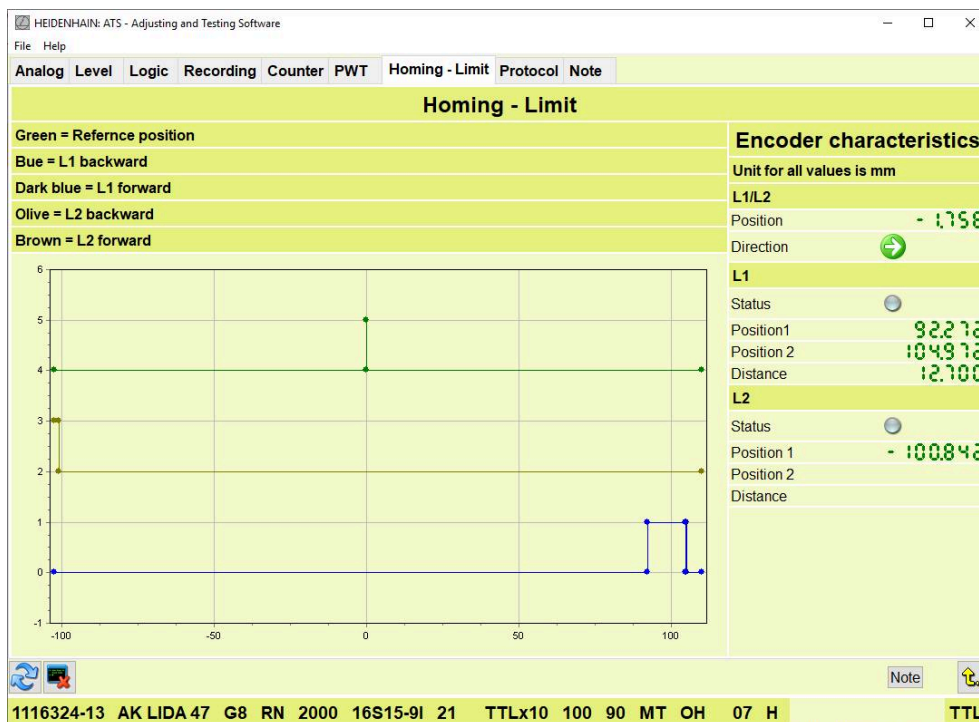

Figure 82: **Homing – Limit** view of the **Incremental signal** function

Bar graph

In the diagram, the signals with their respective traverse directions are color-coded.

Depiction	Description
Green	Reference signal
Blue	Homing backward
Dark blue	Homing forward
Olive green	Limit backward
Brown	Limit forward

Encoder characteristics section

All values in mm

Depiction	Description
Position	Count value of incremental counter Unit: millimeters
Direction	The arrow symbol shows the traverse direction <ul style="list-style-type: none"> ■ Arrow to the right: positive count value recorded ■ Arrow to the left: negative count value recorded



Homing/L1/Pin 6 (depending on encoder)

Depiction	Description
Status	Status display of the homing level <ul style="list-style-type: none"> ■ Gray: low level ■ Green: high level
Position	Distance between homing edge and reference mark R Unit: millimeters

Limit/L2/Pin 8 (depending on encoder)

Depiction	Description
Status	Status display of the limit level <ul style="list-style-type: none"> ■ Gray: low level ■ Green: high level
Position 1	Distance between limit edge 1 and reference mark R Unit: millimeters
Position 2	Distance between limit edge 2 and reference mark R Unit: millimeters
Distance	Distance between limit edge 1 and limit edge 2 Distance = Limit edge 1 + Limit edge 2

Operating elements

Icon	Function
	Delete measured values Deletes the measured values for a new measurement
	Transfer data to Protocol view Transfers the displayed data to the Protocol view
	Notes Indicates that there is new information on the current measurement

10.2.10 Checking limit switching signals (Homing – Limit view)

Preconditions:

- The encoder features limit switching signals
- The encoder is correctly mounted and electrically adjusted according to the mounting instructions
- The encoder was connected to the Adjusting and Testing Software by entering the encoder ID



For detailed information on the availability and function of switching signals, refer to the encoder documentation or the brochure "Interfaces of HEIDENHAIN Encoders".

Further information: "Opening documentation", Page 47



- ▶ Double-click **Incremental signal** in the function menu
- ▶ Click the **Homing – Limit** tab to switch to the **Homing – Limit** view

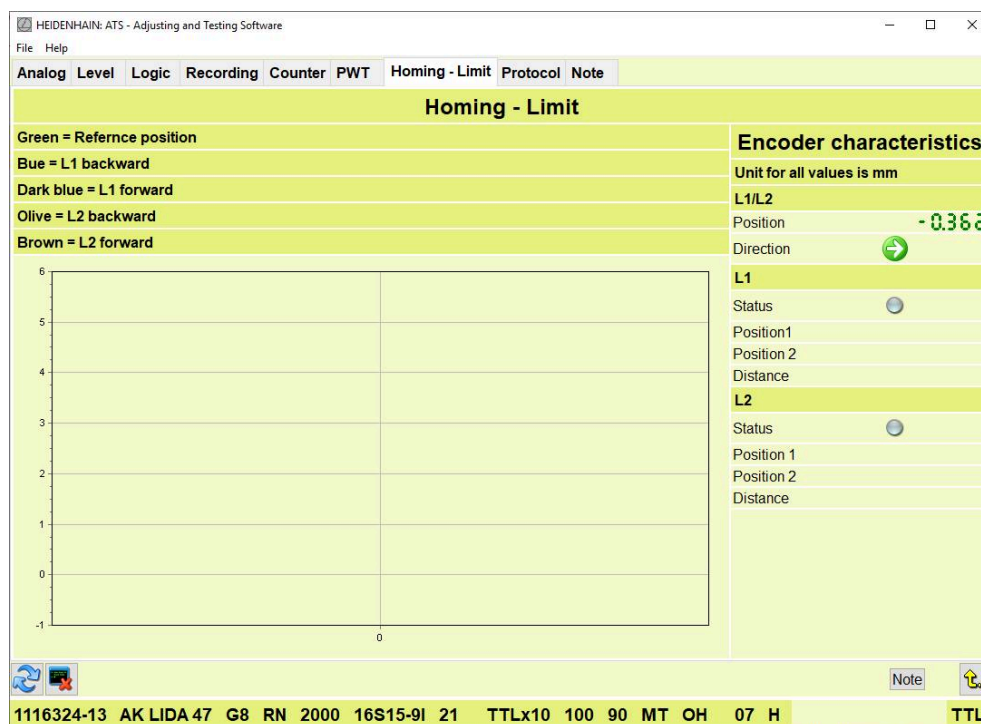

Figure 83: **Homing – Limit** view of the **Incremental signal** function

- ▶ Traverse the entire measuring range
- Recording of the measured values in the diagram starts as soon as the first reference mark is traversed
- When the last reference mark has been traversed, the entire measuring range is displayed in the diagram with homing and limit switching edges (depending on the encoder)

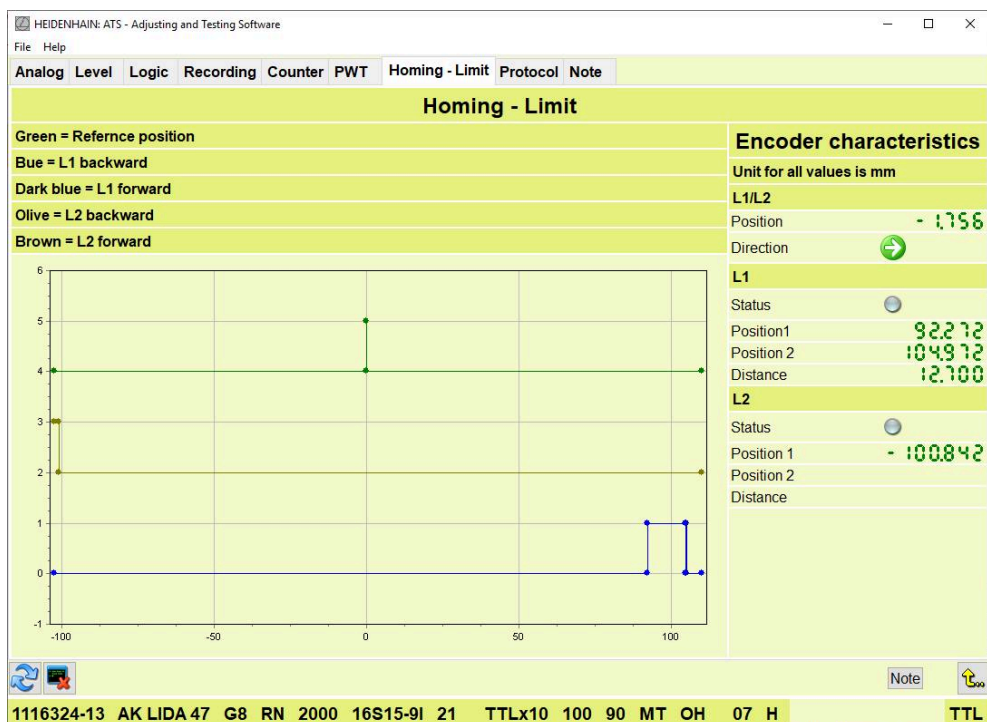

Figure 84: **Homing – Limit** with reference mark and switching edges



You can save and print the active diagram.

Further information: "Adjusting, exporting and printing diagrams", Page 48



You can transfer the displayed data to the **Protocol** screen and save them later on as a log file (PDF format).

Further information: "Transferring data to the Protocol view", Page 108



- ▶ To reset the diagram for a new measurement, click **Delete measured values** in the control bar

10.2.11 Protocol view

You can transfer data from the views of the **Incremental signal** function to the **Protocol** view.

Further information: "Transferring data to the Protocol view", Page 108



The data recorded in the **Protocol** view can be saved to a PDF file. In the **Selection** field, the **Protocol** view shows the data according to the view in which the data was captured. In the **Comment** field, you can enter notes that will be transferred to the PDF file.

 The data are temporarily retained in the **Protocol** view until you exit the **Incremental signal** function.

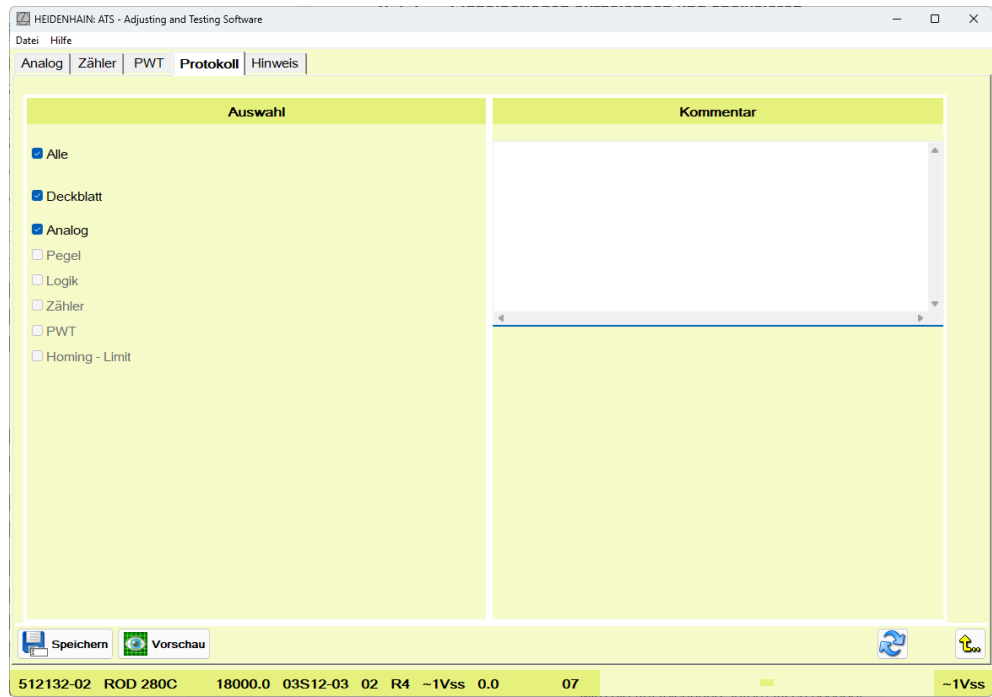
 If there are any test limits for the signal then they are saved to the protocol.



Operating elements

Icon	Function
	Save log Opens the Save file dialog
	Preview Displays a log preview
	Reset a comment Deletes the text in the Comment field

10.2.12 Saving log data (Protocol view)

You can save the test results in a PDF file.

- ▶ Click the **Protocol** tab to switch to the **Protocol** view
- > The selection of the available contents is displayed in the **Selection** field.

Displaying the log preview



- ▶ Click **Preview** to open a preview of the PDF file
- > A new **Preview** window opens and shows the preview
- ▶ Close the **Preview** window to return to the Adjusting and Testing Software

Saving the log



- ▶ Click **Save log**
- ▶ Click **Save** in the dialog box
- ▶ Select the desired storage location
- ▶ Enter the file name
- ▶ Click **Save**
- > The file is saved



In the Adjusting and Testing Software, you can add an individual header and details on the examiner to the logs.

Further information: "Saving log information", Page 57



To display the PDF contents correctly, the font "Arial Unicode MS" must be installed on the computer.

10.2.13 Note view

The **Note** view contains information on the current measurement.

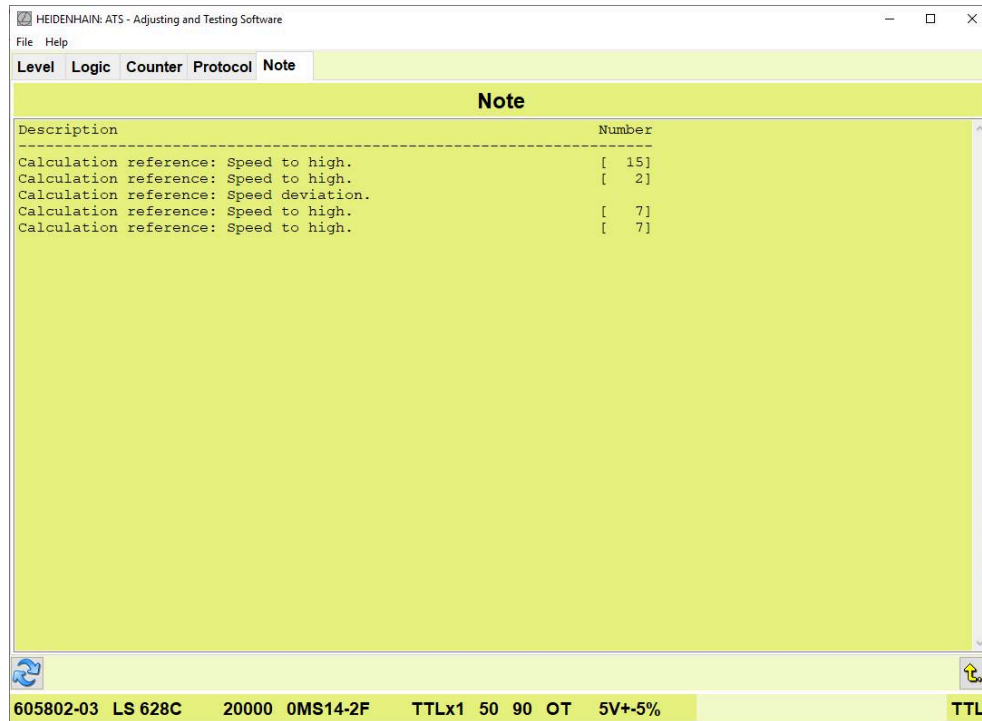



Figure 85: **Note** view of the **Incremental signal** function

The notes refer to problems with signal calculation, e.g.:

- Signal frequencies are too high, e.g. due to excessive traversing speed or shaft speed
- Signal frequency fluctuates
- Displayed signal detail is too small to calculate the reference mark correctly

Operating elements

Icon	Function
	Delete notes Deletes the notes for a new measurement

10.2.14 Displaying and deleting notes (Note view)



A warning symbol appears in the control bar when there is a new note. Go to the **Note** view to read the note.

- ▶ Click **Note** in the control bar
- > The **Note** view shows a list of all notes



Notes are retained until you exit the **Incremental signal** function or delete the notes by hand.

Deleting notes



- ▶ Click **Delete notes** in the control bar to delete all notes

10.3 Checking voltage supply

10.3.1 Voltage display function

The **Voltage display** function shows the measured values and status of the voltage supply. The display depends on the operating mode of the testing device.

Operating mode of the testing device	Displayed voltage values
Encoder diagnostics	Encoder powered by the PWM
Monitoring operation with signal adapter	Signal adapter powered by the PWM
Monitoring operation without signal adapter	Encoder powered by the downstream electronics



▶ Double-click **Voltage display** in the function menu

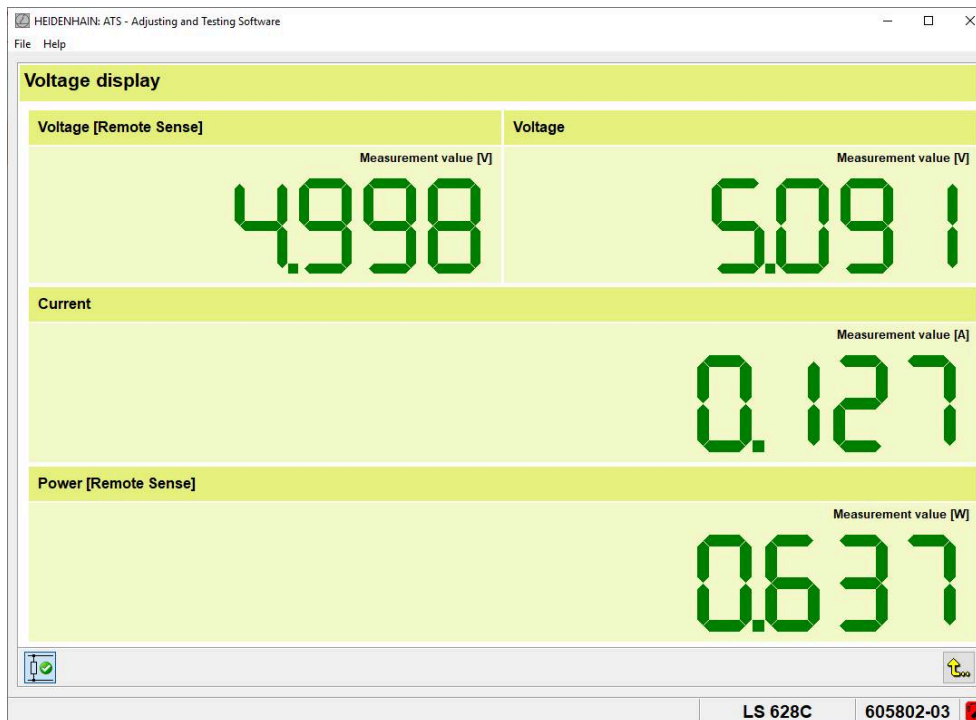



Figure 86: **Voltage display** function





Display	Description
Voltage [Remote Sense]	Operating voltage at the encoder Voltage drops on the encoder supply lines are taken into account. [Remote Sense] : Indicates that voltage readjustment is active
Voltage	Voltage output by the PWM or the downstream electronics
Current	Current consumption of the encoder or the signal adapter <div style="border: 1px solid black; padding: 5px; margin: 5px 0;"> <p>i If the encoder does not consume any current, the measured value is displayed in red.</p> </div>
Power [Remote Sense]	Power consumption of the encoder [Remote Sense] : Indicates that voltage readjustment is active

Operating elements

Icon	Function
	Deactivate terminating resistor Switches the terminating resistor off
	Activate terminating resistor Switches the terminating resistor on

10.3.2 Deactivating the terminating resistor

In the Encoder Diagnostics mode, the terminating resistor is activated by default. You can deactivate the terminating resistor to check whether the current consumption of the encoder corresponds to the technical specifications (e.g., the typical current consumption).

-  ▶ Click **Deactivate terminating resistor** in the control bar
-  > The operating element indicates that the terminating resistor is inactive
-  ▶ Click **Activate terminating resistor** to reactivate the terminating resistor
-  > The operating element indicates that the terminating resistor is active

i When you exit the function view, the terminating resistor is automatically reactivated.

i In the monitoring mode, the terminating resistor is inactive and cannot be switched on.

10.4 Displaying and copying encoder information

10.4.1 Encoder information function

With the **Encoder information** function you can view information on the connected encoder and copy it to the clipboard to reuse the texts in other applications.

 Some functions of the Adjusting and Testing Software are only available if you connect the encoder through its encoder ID (recommended procedure).



► To call this function, double-click **Encoder information** in the function menu

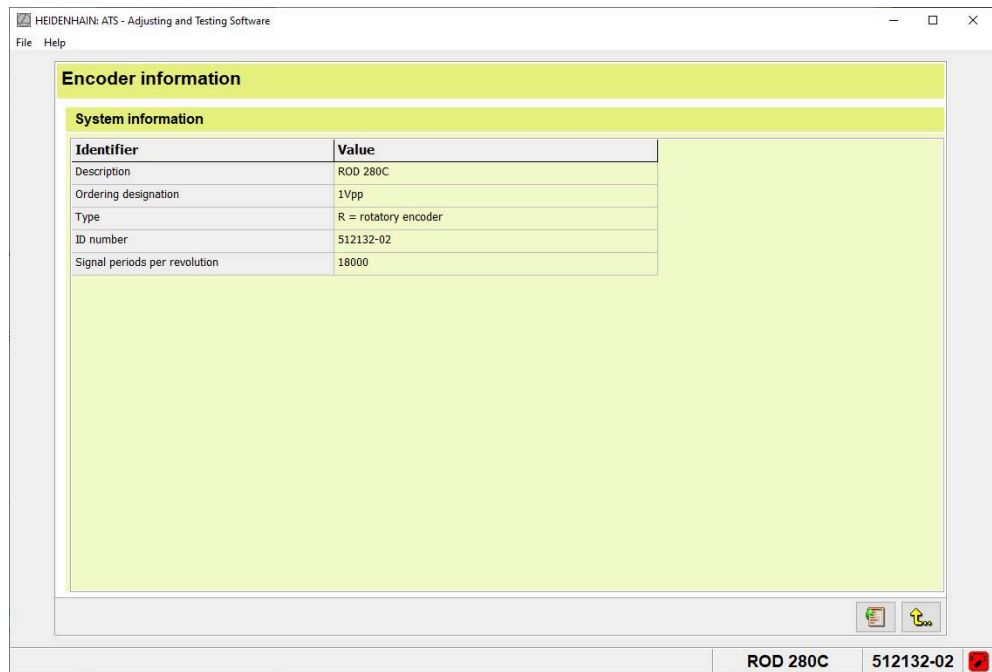



Figure 87: **Encoder information** function

Operating elements

Symbol	Function
	<p>Copy encoder information</p> <p>Copies the displayed encoder information to the clipboard as text</p>

11

**Inspecting encoders
with serial interface
(EnDat 2.1 EnDat
2.1,
EnDat 2.2 and
proprietary
interfaces)**

11.1 Overview



In this chapter, the procedure and user interface are described using the EnDat 2.2 interface as an example.

For differences and special functions of other serial interfaces, refer to the chapter "Special interface-specific functions".

The procedure and user interface for encoders with EnDat 3 interface are in the chapter "Inspecting encoders with serial interface of the EnDat 3 type".

The Adjusting and Testing Software features the following functions for inspecting encoders with serial interface:

Icon	Function	Description
	Position display	Current encoder position and status information
	Incremental signal display	Tolerance check of the incremental signals
	Voltage display	Measured values of voltage and current supply
	Absolute to incremental deviation	Check agreement of absolute track and incremental track
	Online diagnostics	Determine the function reserves of the encoder based on valuation numbers
	Functional-safety encoder check	Check safety-relevant encoder functions
	Display encoder memory	Load the encoder configuration from the encoder, edit the configuration and transmit it to the encoder; save the encoder configuration to a file
	Compare contents of encoder memories	Compare encoder configurations to each other
	Additional information Position value 2	Display of position values 1 and 2



The displays and the scope of functions of the Adjusting and Testing Software depend on the connected encoder and on the software configuration. When you establish the connection to the encoder, the function menu shows the available functions and operating elements.

11.2 Checking position values, transmission and encoder status

11.2.1 Position display function

For linear and rotary encoders, the position display shows the current encoder position.

For touch probes, the position display shows information on the trigger information and the status of the touch probe.

Depending on the encoder model, information on encoder alarms and warnings and on the quality of the incremental signals are available in addition.



► To call this function, double-click **Position display** in the function menu

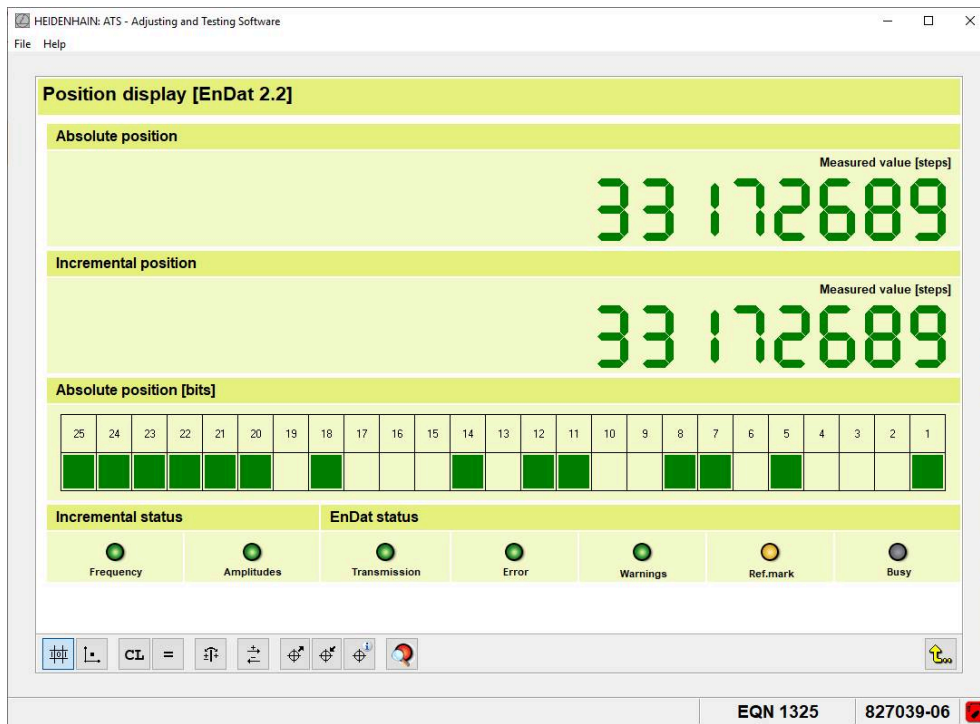

Figure 88: **Position display** function









Display	Description
Absolute position	<p><i>For linear and rotary encoders:</i> Absolute encoder position Unit: increments</p> <p><i>For encoders with strain sensor:</i> Absolute encoder position Unit: nano-epsilon</p>
Incremental position	<p><i>For linear and rotary encoders:</i> Count value of incremental counter Unit: increments</p>

Display	Description
Absolute position [bits]	<p><i>For linear and rotary encoders:</i> Binary display of the absolute encoder position The number of bits depends on the encoder. Bit 1 = LSB (Least Significant Bit)</p> <p><i>For touch probes:</i> The binary display provides information on the following signals:</p> <ul style="list-style-type: none"> ■ Bit 1: Trigger state ■ Bit 2: Trigger state valid ■ Bit 3: Sensor is ready ■ Bit 4: Touch probe is ready ■ Bit 5: Battery warning ■ Bit 6: Collision <p>Correct behavior of the touch probe: If there is no probing event and if the battery voltage is within the tolerance range, then the bits 2, 3 and 4 are set.</p>
Frequency	<p>Status display of signal frequency</p> <ul style="list-style-type: none"> ■ Green: Signal frequency is within tolerance ■ Red: Signal frequency is outside the tolerance range
Amplitudes	<p>Status display of signal amplitudes</p> <ul style="list-style-type: none"> ■ Green: The signal amplitudes are within the tolerance range ■ Red: The signal amplitudes exceed at least one tolerance limit
Transmission	<p>Status display of data transfer between encoder and testing device</p> <ul style="list-style-type: none"> ■ Green: No status message available ■ Red: Status message available
Fault	<p>Status display of encoder errors</p> <ul style="list-style-type: none"> ■ Green: No status message available ■ Red: Status message available
Warnings	<p>Status display of encoder warnings</p> <ul style="list-style-type: none"> ■ Green: No status message available ■ Red: Status message available
Ref.mark	<p>Status display of reference mark detection</p> <ul style="list-style-type: none"> ■ Gray: No reference mark was detected ■ Yellow: Reference mark detected or absolute encoder
Busy	<p>Status display of memory access</p> <ul style="list-style-type: none"> ■ Gray: No access to encoder memory detected ■ Yellow: Access to encoder memory detected





At this point, access to the encoder memory suggests an encoder error.

Operating elements

Icon	Function
	Show measured values Displays the measured value in increments
	Show position values Converts the measured value into a position value Unit: micrometers, degrees, or nano-epsilons (depending on the encoder)
	Display in degrees Converts the measured value into degrees
CL	Clear counter Sets the incremental position to zero
=	Equate counter Sets the incremental position to the absolute position value
	Synchronize counter Synchronizes the counters at zero position
	Invert counting direction Inverts the positive or negative counting direction
	Set datum shift Opens the dialog for setting the datum shift
	Cancel datum shift Opens the dialog for deleting the datum shift
	Show datum shift Displays information on existing datum shift
	Show status information Displays a list of errors and warnings

11.2.2 Classification of the status messages

Status report	Description
Warnings	<p>Warnings indicate that certain tolerance limits of the encoder have been reached or exceeded.</p> <p>Examples of encoder warnings that may be displayed by encoders with EnDat interface:</p> <ul style="list-style-type: none"> ■ Bit 0 – Frequency exceeded ■ Bit 1 – Temperature exceeded ■ Bit 2 – Light source control reserve <p>Encoder warnings do not indicate whether the transmitted position values are correct.</p>
Errors	<p>Errors indicate a malfunction of the encoder.</p> <p>Examples of encoder errors that may be displayed by encoders with EnDat interface:</p> <ul style="list-style-type: none"> ■ Bit 0 – Light source failure ■ Bit 1 – Signal amplitude faulty ■ Bit 2 – Position faulty ■ Bit 3 – Overvoltage ■ Bit 4 - Undervoltage supply ■ Operating status error sources <div data-bbox="576 1133 1216 1263" style="border: 1px solid black; padding: 5px; margin-top: 10px;"> <p> If there are status messages on encoder errors, the transmitted position values are not reliable.</p> </div>
Transmission	<p>Transmission errors indicate communication errors that may be caused by EMC influences, for example.</p> <p>Examples of transmission errors that may be displayed by encoders with EnDat interface:</p> <ul style="list-style-type: none"> ■ Timeout ■ CRC error

 The **Encoder status** dialog shows the errors and warnings transmitted by the encoder and the status messages on transmission.
Further information: "Displaying status messages", Page 209

 To see which status messages the encoder supports, refer to the encoder configuration.
Further information: "Overview of supported error messages and warnings", Page 261

11.2.3 Switching between measured values view and position view

You can switch the counter display between measured values view and position view.

Measured values view

The **Measured values view** shows the count value in increments.

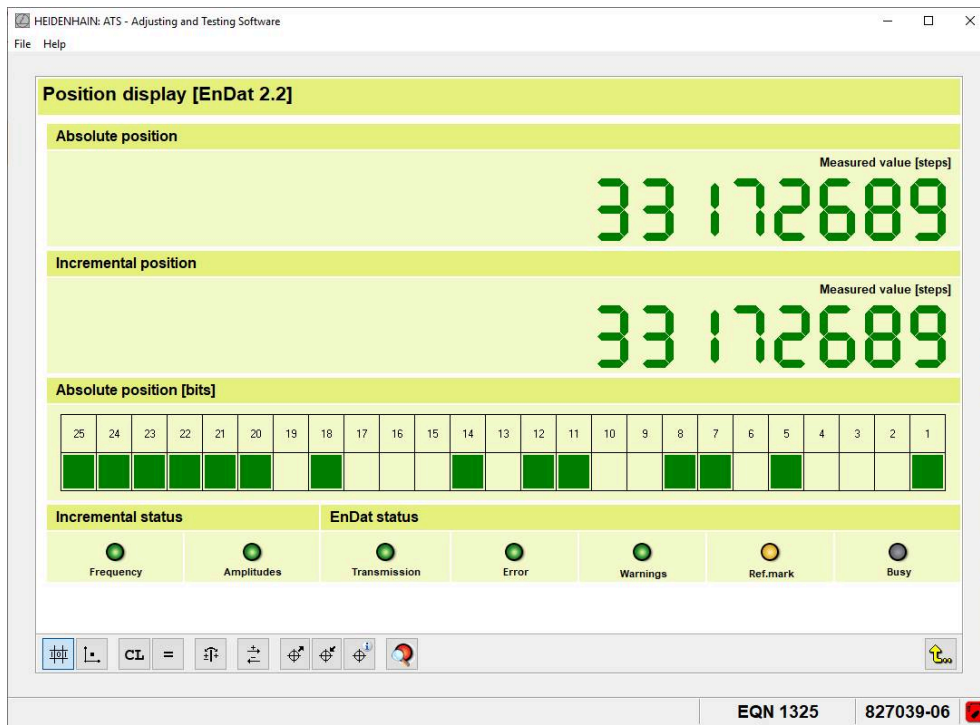

Figure 89: **Measured values view** of the **Position display** function

Position view

In the **Position view**, the Adjusting and Testing Software converts the count value into a position value. The position value is displayed in micrometers, degrees, or increments (depending on the encoder).

For multiturn rotary encoders, the Adjusting and Testing Software in addition displays the number of revolutions in the **Position display**.

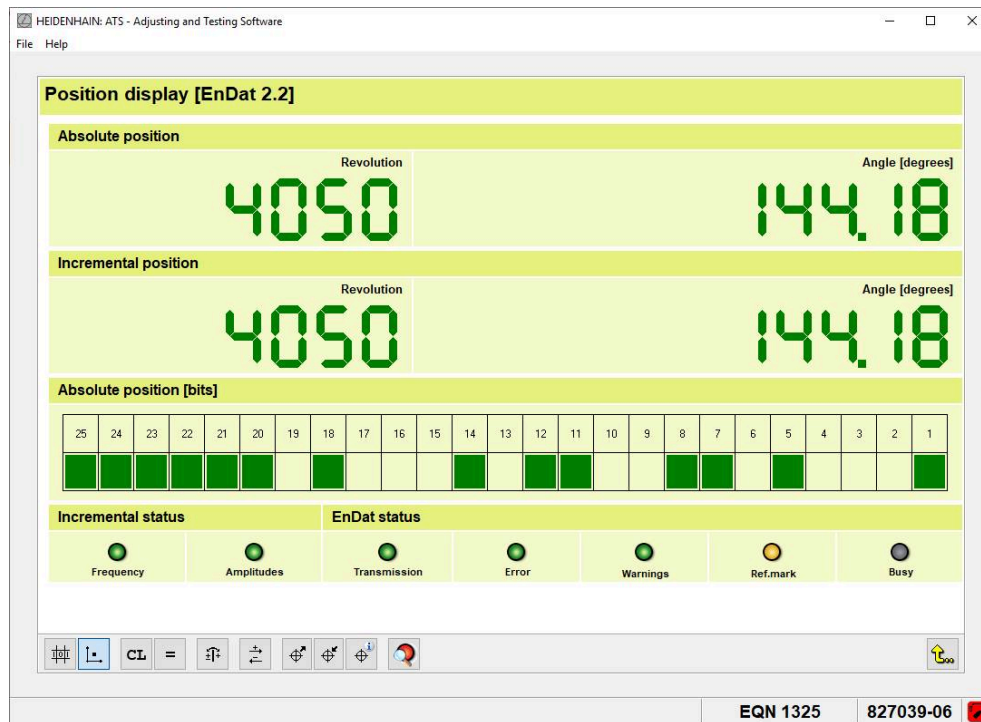

Figure 90: **Position view** of the **Position display** function

Switching between the views



- ▶ Click **Show measured values** in the control bar to switch to the measured values view



- ▶ Click **Show position values** in the control bar to switch to the position view

11.2.4 Converting the measured value into degrees

For linear encoders designed to scan a segment of a circle, you can switch the measured value display to degrees.

Precondition: The encoder was connected to the Adjusting and Testing Software by entering the encoder ID. The software uses the ID to determine the encoder scanning diameter required for the calculation.



- ▶ Click **Display in degrees** in the control bar to show the calculated angular value



The displayed value can be outside the value range $0^\circ \dots 360^\circ$, since the angle is calculated directly from the measured linear value.

11.2.5 Clearing the incremental counter

CL

- ▶ Click **Clear counter** in the control bar to delete the incremental counter
- > The incremental counter is set to zero

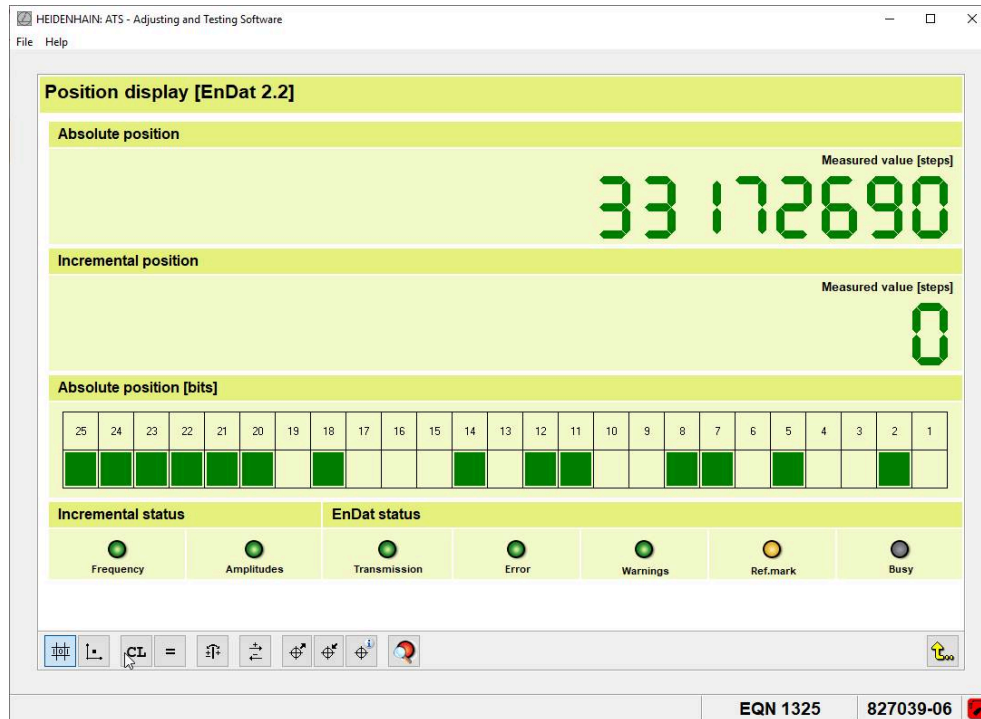

Figure 91: Position display after clearing the incremental counter

11.2.6 Equating the incremental counter with the absolute position



- ▶ Click **Equate counter** in the control bar to equate the count values
- The incremental counter assumes the count value of the absolute position

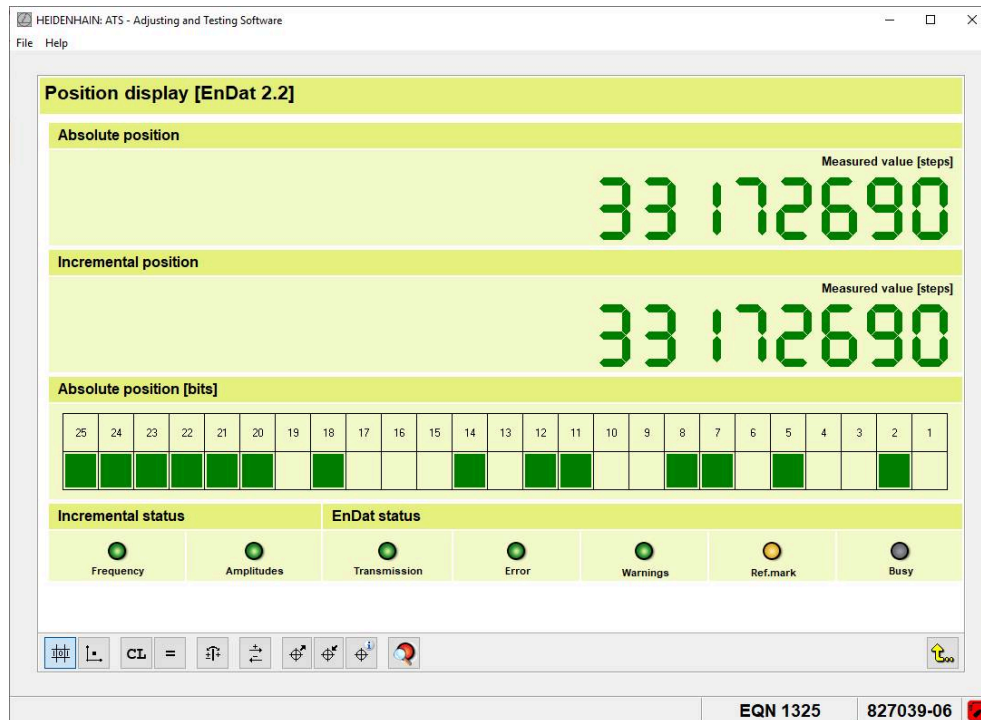

Figure 92: Position display with incremental and absolute positions set equal

11.2.7 Synchronizing the counters

When an encoder passes zero crossover in negative direction, the counters behave as follows:

- The **Absolute position** counter jumps to the highest position value, in the example 8191
- The **Incremental position** counter jumps to -1

... 8189, 8190, 8191 1, 2, 3, ...
 ... -3, -2, -1 1, 2, 3, ...

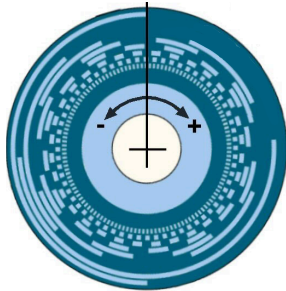

Figure 93: Counter limit of a 13-bit rotary encoder

When you activate the synchronization mode, both counters jump to the highest position value when the zero crossover is passed.



- ▶ Click **Synchronize counters** in the control bar to switch the counting logic of the incremental counter

11.2.8 Inverting the counting direction of the incremental counter

On some encoders, the counting direction of the incremental counter can be configured. You can adapt the counting direction to the encoder in the Adjusting and Testing Software.



- ▶ Click **Invert counting direction** in the control bar to adapt the counting direction
- > The Adjusting and Testing Software inverts the positive or negative counting direction

11.2.9 Setting datum shift

In the **Position display** function, you can shift the datum of the connected encoder. The datum shift enables you to adapt the encoder to the machine for each individual axis (e.g., for measuring the rotor position on synchronous motors).

Precondition: The encoder supports datum shift.

A license key (software option) is required to set the datum shift.

Further information: "Enabling software options", Page 53

⚠ WARNING

Danger of uncontrolled axis movements due to datum shift

If you select an incorrect value for datum shift, uncontrolled movements of the machine axes may occur. This may result in death, serious injuries, or damage to equipment.

- ▶ Observe the manufacturer's documentation of the machine tool and the encoder
- ▶ Shift the datum only if absolutely necessary (e.g., if the encoder is exchanged)
- ▶ Shift the datum only while the encoder is at a standstill
- ▶ Leave the traverse range of the machine before setting a datum shift
- ▶ Cancel any datum shift before setting a new one
- ▶ Only execute datum shifts in the **Position display** function
- ▶ Do not manually change the "Zero point" value in the encoder configuration

⚠ WARNING

Danger from falling machine axes

Non-secured vertical or hanging machine axes may fall down due to datum shift. This may result in death or serious injuries.

Before setting a datum shift:

- ▶ Secure the machine axes
- ▶ Leave the traverse range of the machine

i Linear encoders with EnDat interface do not support negative position values. Instead of the negative sign, the following position value is output:
2Number of clock pulses for transfer of position value

- ▶ For linear encoders with EnDat interface, select the datum such that only position values > 0 are output

i A datum shift may require a new acceptance test (e.g., in the case of functionally safe applications).

i First check whether a datum shift is active and reset it if necessary.
Further information: "Checking the datum shift", Page 208
Further information: "Resetting a datum shift", Page 209

The following options are available for setting a datum shift:

- **Set datum to current position:**
Approach the desired position and adopt this position as zero point
- **Set datum to absolute position:**
Enter the desired position value manually

i Which options are available for the datum shift depends on the connected encoder.

Setting the datum to current position



- ▶ Move to the desired position
- ▶ Click **Set datum shift** in the control bar
- ▶ The Adjusting and Testing Software displays information on the datum shift
- ▶ Click **Yes**
- ▶ The **Datum shift** dialog is displayed

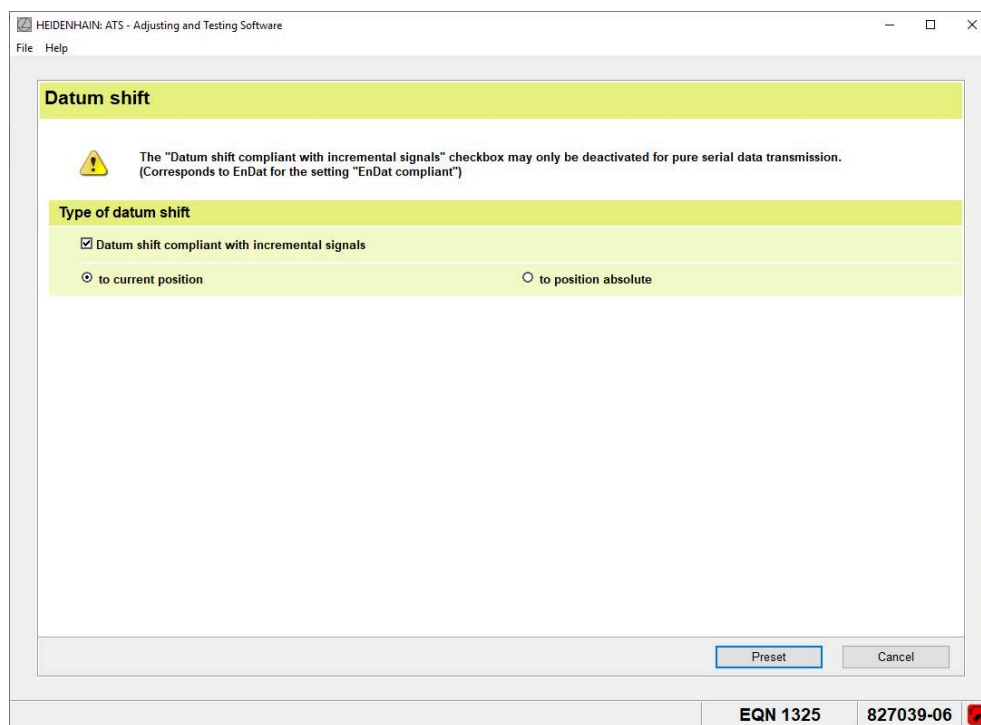

Figure 94: **Datum shift** dialog

- ▶ For encoders with incremental signals, place a check mark at **Datum shift compliant with incremental signals**

i If the check mark is set, the Adjusting and Testing Software calculates the new zero point such that it is as close as possible to the desired position and in accordance with the EnDat specification.

- ▶ In the **Type of datum shift** section, select the option **to current position**
- ▶ Click **Set**
- ▶ The current position is saved in the encoder as the new datum

Setting the datum to absolute position



- ▶ Click **Set datum shift** in the control bar
- The Adjusting and Testing Software displays a note
- ▶ Click **Yes**
- The **Datum shift** dialog is displayed

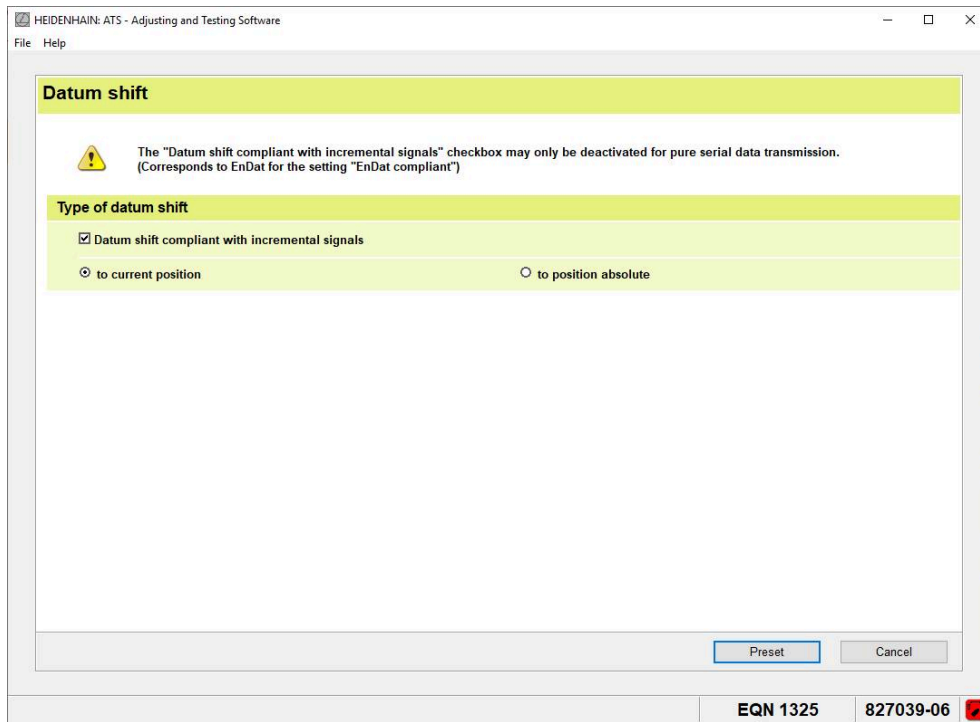

Figure 95: **Datum shift** dialog

- ▶ For encoders with incremental signals, place a check mark at **Datum shift compliant with incremental signals**

i If the check mark is set, the Adjusting and Testing Software calculates the new zero point such that it is as close as possible to the desired position and in accordance with the EnDat specification.

- ▶ In the **Type of datum shift** section, select the option **to absolute position**
- The **Set to absolute position** section is displayed
- The values in the **Position** field are displayed in increments
- ▶ To change the unit of the **Position** field to micrometers or degrees (depending on the encoder), remove the check mark at **Datum shift in steps**
- The values in the **Position** field are displayed in the respective unit

Set to absolute position

Datum shift in steps

Position [steps]

Figure 96: **Position** input field in increments

Set to absolute position

Datum shift in steps

Position of current Revolution [Revolutions]

Position within the revolution [degrees]

Figure 97: **Position** input field in degrees

- ▶ Enter the desired position value
- ▶ Click **Set**
- The entered position value is saved in the encoder as the new datum

11.2.10 Checking the datum shift

In the **Position display** function you can check whether a datum shift is active.

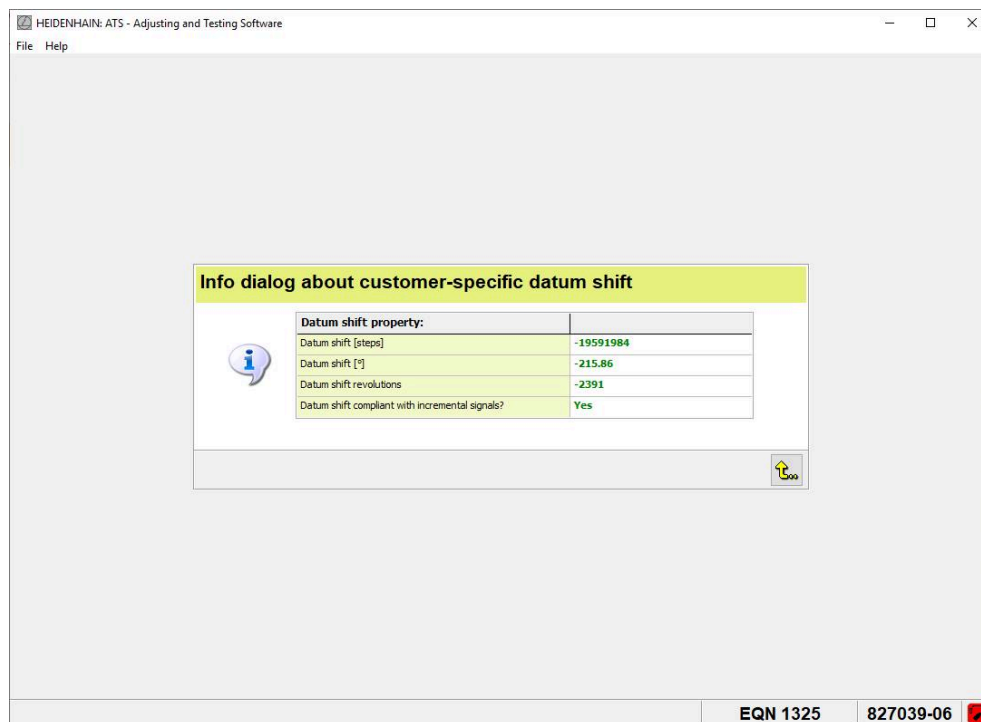

- ▶ Click **Show datum shift** in the control bar
- The **Info dialog about customer-specific datum shift** is displayed

Figure 98: **Info dialog about customer-specific datum shift**

- If a datum shift is active, the **Info dialog about customer-specific datum shift** contains the following information:
 - Datum shift in steps
 - Datum shift in micrometers or degrees (depending on the encoder)
 - Datum shift in revolutions (depending on the encoder)
 - Datum shift compliant with incremental signals

11.2.11 Resetting a datum shift

You can reset the datum to the factory default setting of the encoder.



- ▶ Click **Cancel datum shift** in the control bar
- > The **Cancel datum shift** dialog is displayed
- ▶ Click **Yes**
- > The datum shift is reset

11.2.12 Displaying status messages

The **Encoder status** dialog shows the errors and warnings transmitted by the encoder and the status messages on transmission.



To see which status messages the encoder supports, refer to the encoder configuration.

Further information: "Overview of supported error messages and warnings", Page 261



- ▶ Click **Show status information** in the control bar to show the **Encoder status** dialog

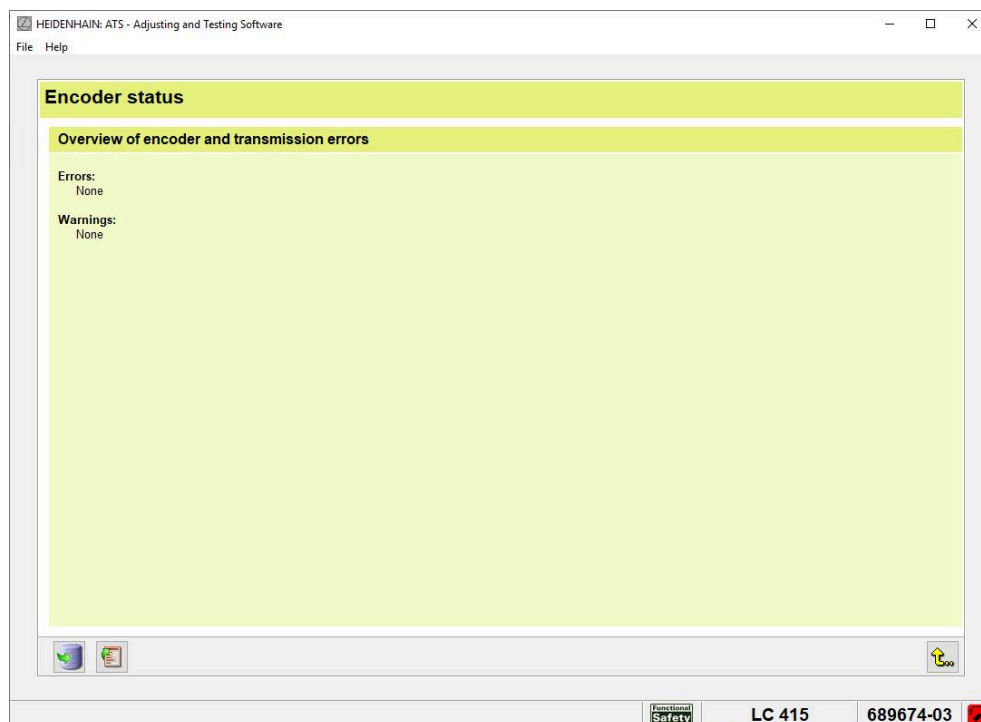

Figure 99: **Encoder status** screen

11.2.13 Displaying operating status error sources

The operating status error sources are an expansion of the EnDat 2.2. error register. They provide detailed information on the encoder errors that have occurred.



To see which operating status error sources the encoder supports, refer to the encoder configuration.

Further information: "Overview of supported operating status error sources", Page 262



- ▶ Click **Show status information** in the control bar to show the **Encoder status** dialog

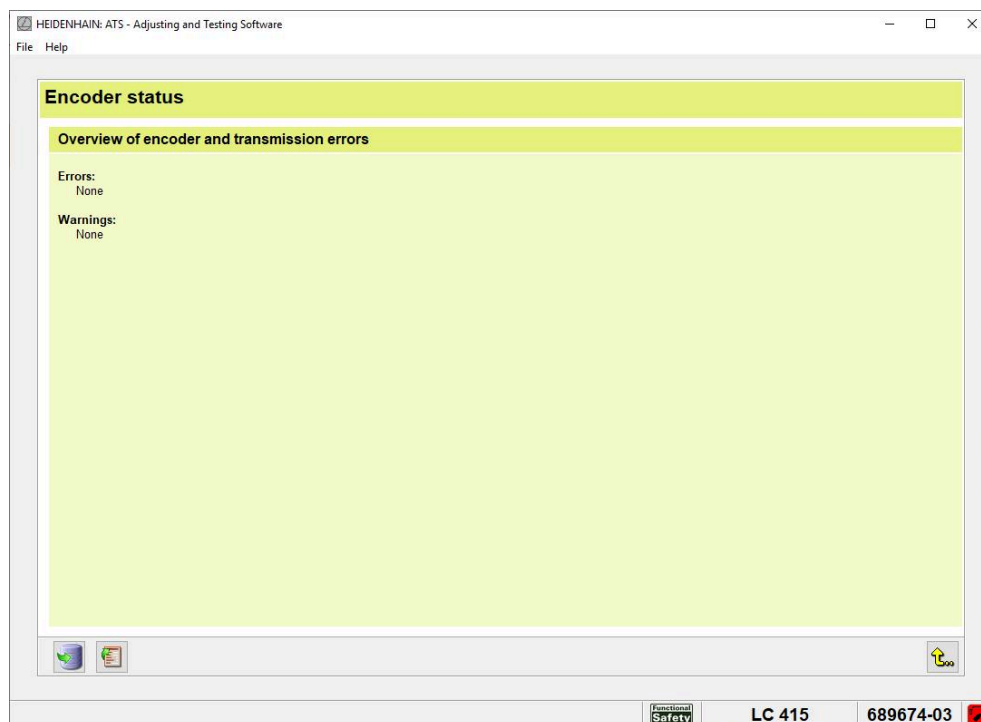

Figure 100: **Encoder status** screen



- ▶ Click **Read operating status error sources**
- ▶ The **Encoder status** screen displays the **Overview of operating status error sources**

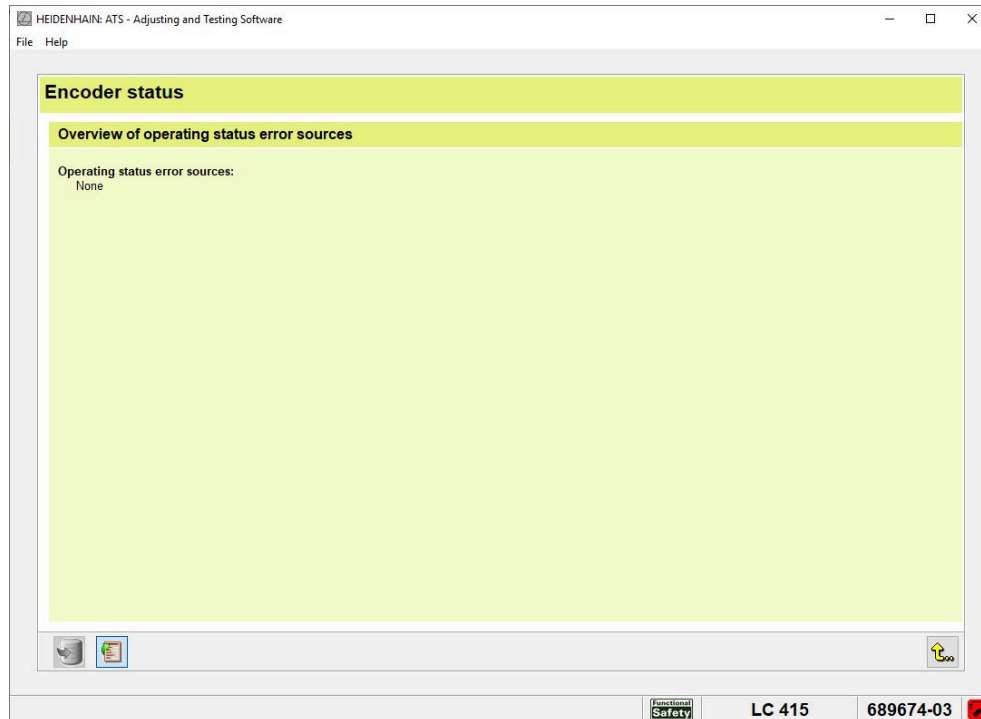

Figure 101: **Encoder status** screen with the **Overview of operating status error sources**

11.2.14 Resetting status messages

You should delete any existing status messages before each check.



- ▶ Click **Show status information** in the control bar to show the **Encoder status** dialog



- ▶ Click **Delete status messages**
- > The status messages are deleted



If there are still status messages in the **Encoder status** detail view, this indicates that the corresponding errors are still present.

11.3 Checking incremental signals

11.3.1 Incremental signal function

If the encoder provides incremental signals, you can examine these signals with the **Incremental signal** function. The procedure is the same as for checking incremental encoders.

More information on checking sinusoidal incremental signals:

"Incremental signal function", Page 93

More information on checking square-wave incremental signals:

"Incremental signal function", Page 155

11.4 Checking voltage supply

11.4.1 Voltage display function

The **Voltage display** function shows the measured values and status of the voltage supply. The display depends on the operating mode of the testing device.

Operating mode of the testing device	Displayed voltage values
Encoder diagnostics	Encoder powered by the PWM
Monitoring operation with signal adapter	Signal adapter powered by the PWM
Monitoring operation without signal adapter	Encoder powered by the subsequent electronics



► Double-click **Voltage display** in the function menu

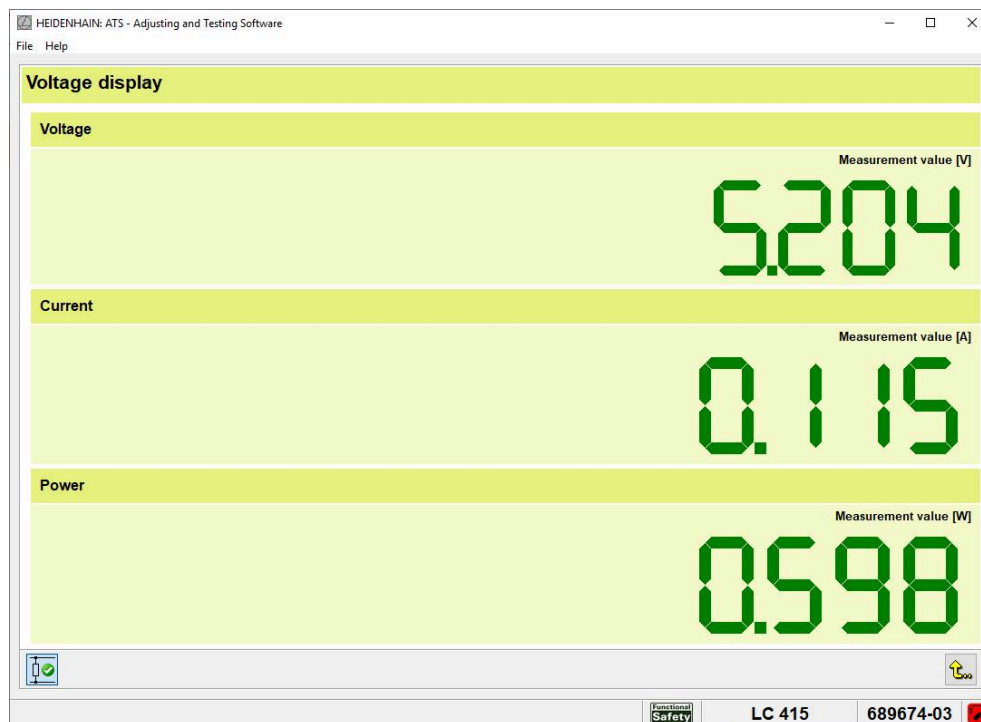

Figure 102: **Voltage display** function

Display	Description
Voltage [Remote Sense]	Operating voltage at the encoder Voltage drops on the encoder supply lines are taken into account. [Remote Sense] : Indicates that voltage readjustment is active
Voltage	Voltage output by the PWM or the downstream electronics
Current	Current consumption of the encoder or the signal adapter <div style="border: 1px solid black; padding: 5px; margin-top: 10px;">i If the encoder does not consume any current, the measured value is displayed in red.</div>
Power [Remote Sense]	Power consumption of the encoder [Remote Sense] : Indicates that voltage readjustment is active

Operating elements

Icon	Function
	Deactivate terminating resistor Switches the terminating resistor off
	Activate terminating resistor Switches the terminating resistor on

11.4.2 Deactivating the terminating resistor

In the Encoder Diagnostics mode, the terminating resistor is activated by default. You can deactivate the terminating resistor to check whether the current consumption of the encoder corresponds to the technical specifications (e.g., the typical current consumption).

- ▶ Click **Deactivate terminating resistor** in the control bar
- > The operating element indicates that the terminating resistor is inactive
- ▶ Click **Activate terminating resistor** to reactivate the terminating resistor
- > The operating element indicates that the terminating resistor is active

i When you exit the function view, the terminating resistor is automatically reactivated.

i In the monitoring mode, the terminating resistor is inactive and cannot be switched on.

11.5 Displaying and copying encoder information

11.5.1 Encoder information function

With the **Encoder information** function you can view information on the connected encoder and copy it to the clipboard to reuse the texts in other applications.



Some functions of the Adjusting and Testing Software are only available if you connect the encoder through its encoder ID (recommended procedure).



► To call this function, double-click **Encoder information** in the function menu

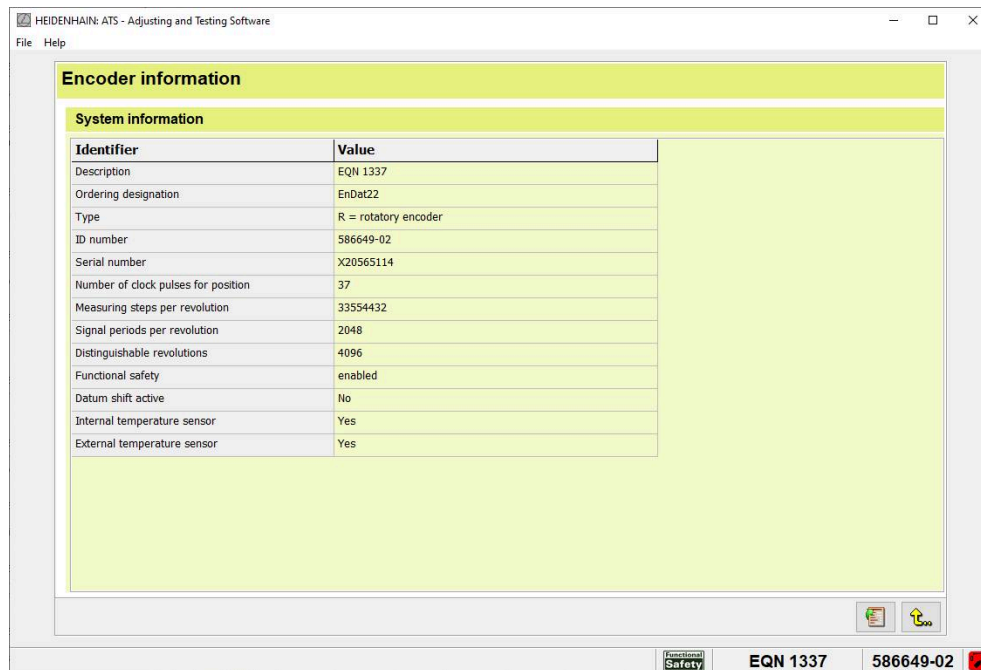

Figure 103: **Encoder information** function

Operating elements

Symbol



Function

Copy encoder information

Copies the displayed encoder information to the clipboard as text

11.6 Checking the agreement of absolute track and incremental track

11.6.1 Absolute to incremental deviation function

With the **absolute to incremental deviation** function you can check whether the deviation between the absolute position and the incremental position is within the tolerance range.

Description of function:

The different signal paths and propagation times result in differences between the absolute and the incremental position values. The Adjusting and Testing Software compares the position values and displays the difference as deviation span. The deviation span is determined for different speed ranges and must not exceed the specified tolerance limits (accuracy ranges).



► To call this function, click **Absolute to incremental deviation** in the function menu

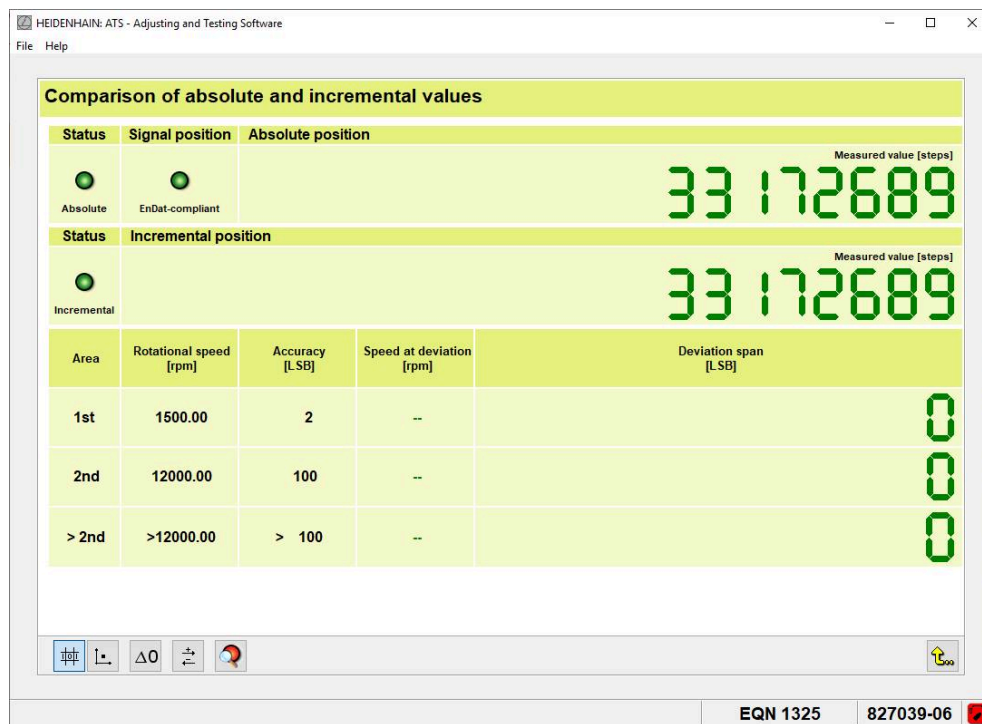

Figure 104: **Absolute to incremental deviation** function

Depiction	Description
Status – Absolute	Status display of encoder errors and encoder warnings for the absolute value <ul style="list-style-type: none"> ■ Green: No status message available ■ Red: Status message available Further information: "Classification of the status messages", Page 198
Status – Incremental	Status display of encoder errors and encoder warnings for the incremental value Description see "Status – Absolute"





Depiction	Description
Signal position – EnDat-compliant	<p>Status display of signal position</p> <p>The Adjusting and Testing Software checks whether the position of the incremental signal corresponds to the EnDat specification, i.e. whether the correct relation can be established between the relative and the absolute position values.</p> <ul style="list-style-type: none"> ■ Green: Signal position is EnDat-compliant; zero position is assigned to the signal period ■ Yellow: Signal position not EnDat-compliant <p>Further information: "Setting datum shift", Page 205</p> <div style="border: 1px solid black; padding: 5px; margin-top: 10px;"> <p>i Depending on the signal resolution, an EnDat non-compliant datum shift may result in a dimensional error that is outside the machine's accuracy specifications.</p> </div>
Absolute position	<p>Current count of the position display</p> <p>Unit: increments</p>
Incremental position	<p>Count value of incremental counter</p> <p>Unit: increments</p>
Range	<p>Linear or rotational velocity range</p>
Speed [m/min]	<p>Display for linear encoders:</p> <p>Speed in the respective speed range</p> <p>Unit: m/min</p>
Rotational speed [rpm]	<p>Display for rotatory encoders:</p> <p>Rotational speed in the respective speed range</p> <p>Unit: rpm</p>
Accuracy [LSB]	<p>Permissible deviation in the respective speed range</p> <p>Unit: LSB¹</p>
Speed at deviation [m/min]	<p>Display for linear encoders:</p> <p>Speed when determining the deviation span</p> <p>If a dash is displayed instead of a value, the encoder does not support the corresponding speed range.</p>
Speed at deviation [rpm]	<p>Display for rotatory encoders:</p> <p>Rotational speed when determining the deviation span</p> <p>If a dash is displayed instead of a value, the encoder does not support the corresponding speed range.</p>

Depiction	Description
Deviation span [LSB]	<p>Determined deviation span Unit: LSB¹</p> <p>The color of the value indicates whether or not the value is within tolerance:</p> <ul style="list-style-type: none"> ■ Green: Deviation span is within the tolerance range ■ Red: Deviation span is outside the tolerance range <div style="border: 1px solid black; padding: 5px; margin-top: 10px;"> <p>i If the deviation span is outside the tolerance limits, check whether the counting direction of the incremental counter corresponds to that of the encoder.</p> <p>Further information: "Inverting the counting direction of the incremental counter", Page 204</p> </div>

¹ LSB = Least significant bit

Example: For a linear encoder with a resolution of 10 nm, 1 LSB corresponds to a measuring distance of 10 nm.

Operating elements

Icon	Function
	<p>Show measured values</p> <p>Displays the measured value in increments</p>
	<p>Show position values</p> <p>Converts the measured value into a position value Unit: micrometers or degrees (depending on the encoder)</p>
	<p>Reset deviation span</p> <p>Equates the incremental position with the absolute position, thus resetting the deviation span to zero</p>
	<p>Invert counting direction</p> <p>Inverts the positive or negative counting direction</p>
	<p>Show status information</p> <p>Displays a list of errors and warnings</p>

11.6.2 Running the inspection

- ▶ Traverse the entire measuring range several times, if possible at different speeds
- The Adjusting and Testing Software determines the deviation span and displays the result of the tolerance check

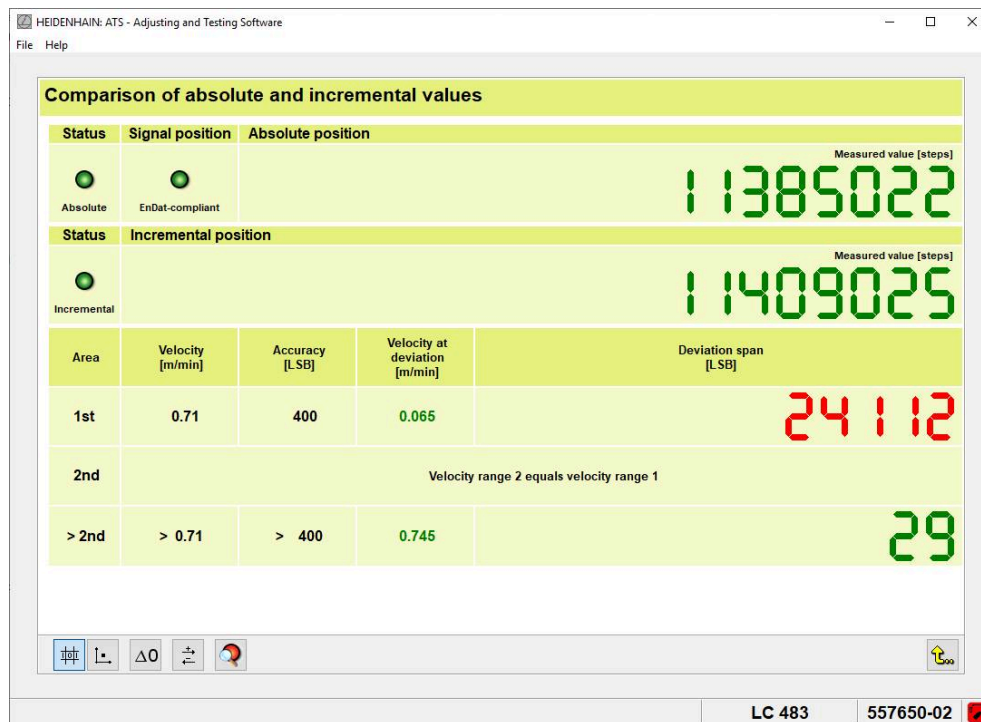

Figure 105: **Absolute to incremental deviation** function when the tolerance limits are exceeded (red value)

i You can switch the counter display between measured values view and position view.

Further information: "Switching between measured values view and position view", Page 199

i On the **Encoder status** screen, you can view status messages and delete them if necessary.

Further information: "Displaying status messages", Page 209

11.6.3 Inverting the counting direction of the incremental counter

On some encoders, the counting direction of the incremental counter can be configured. You can adapt the counting direction to the encoder in the Adjusting and Testing Software.



- ▶ Click **Invert counting direction** in the control bar to adapt the counting direction
- > The Adjusting and Testing Software inverts the positive or negative counting direction

11.6.4 Resetting the deviation span

You can reset the deviation span to repeat the examination.



- ▶ Click **Reset deviation span** in the control bar
- > The count value of the incremental counter is set equal to the absolute position
- > The deviation span is set to zero

11.7 Evaluating the encoder status with the online diagnostics

11.7.1 Online diagnostics function

You can monitor the encoder status with the **Online diagnostics** function.

The Adjusting and Testing Software records valuation numbers, which are transmitted together with the position value when the encoder is traversed. On the basis of these valuation numbers, the Adjusting and Testing Software determines the current function reserves of the encoder.

The **Online diagnostics** functions comprises:

- the **Protocol** view for entry of log data
- the **Measurement** view to determine the function reserves
 - Bar graph
 - X/Y display

Protocol view

In the **Protocol** view, you can enter additional log data. After the measurement, you can save the log as a PDF file.

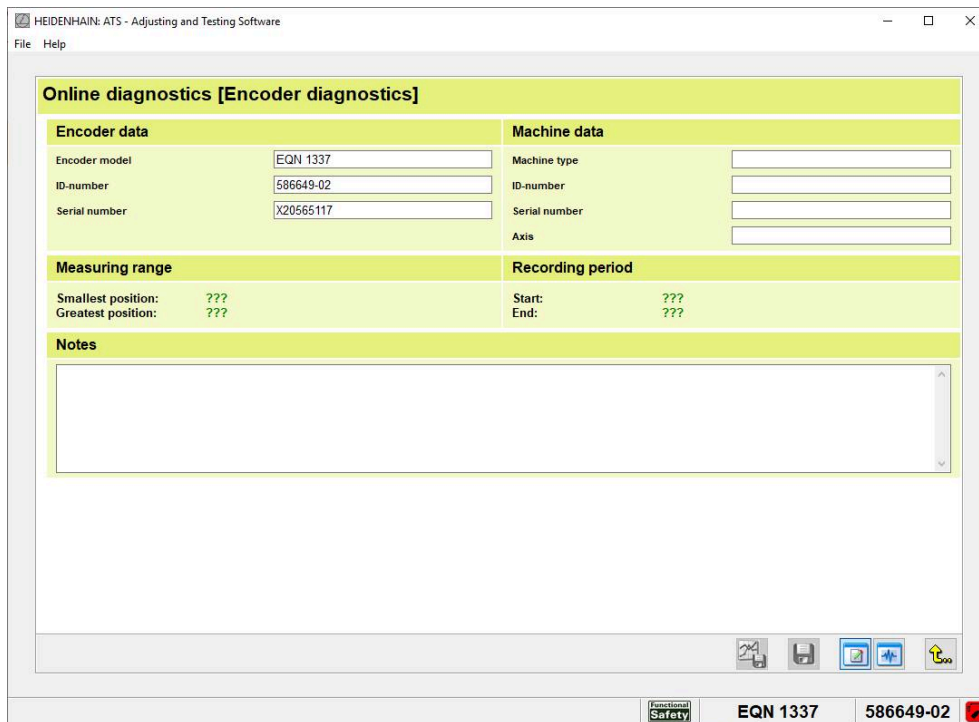





Figure 106: **Protocol** view of the **Online diagnostics** function

Depiction	Description
Encoder data	The fields are filled automatically; the data are adopted from the encoder memory
Machine data	Fields for entering machine data
Measuring range	The fields are filled automatically at the end of the measurement
Recording period	The fields are filled automatically at the end of the measurement
Notes	Field for entering notes

Operating elements

Icon	Function
	Export data Opens the dialog for exporting records to a TXT file
	Save file Opens the dialog for saving the log to a PDF file
	Switch to Protocol view Shows the screen for entering log data
	Switch to Measurement view Shows the screen for running measurements

Measurement screen

In the **Measurement** view, you can monitor the status of the encoder.

The Adjusting and Testing Software records valuation numbers, which are transmitted together with the position value when the encoder is traversed. On the basis of these valuation numbers, the Adjusting and Testing Software determines the current function reserves of the encoder.

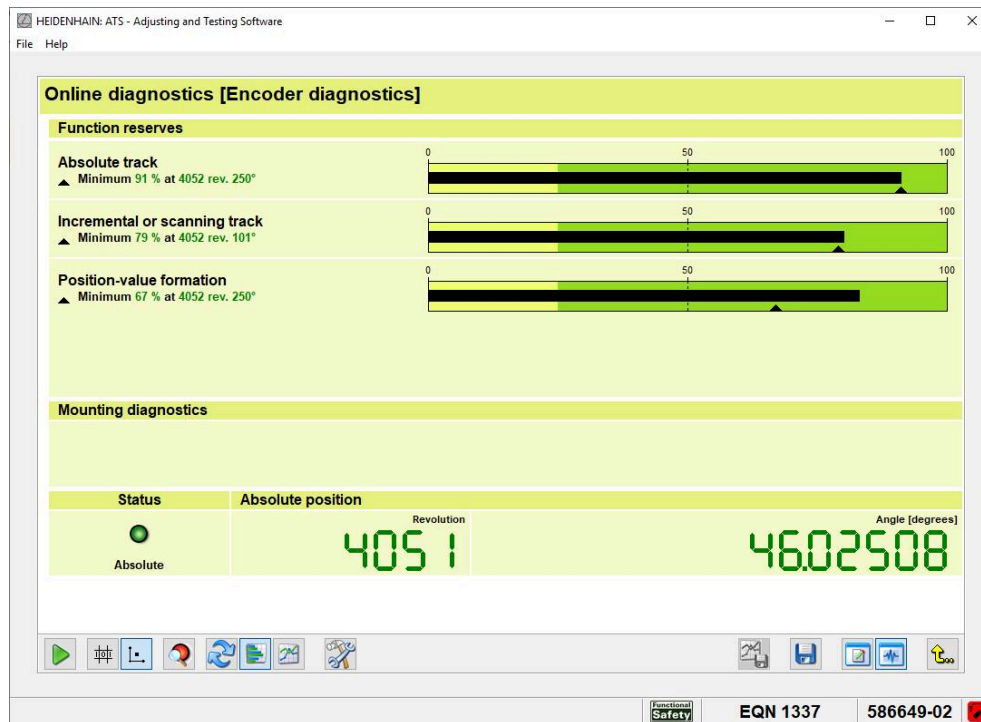

Figure 107: Measurement view of the Online diagnostics function

Display	Description
Functional reserves	<p>The following valuation numbers are transferred and displayed, depending on the connected encoder:</p> <ul style="list-style-type: none"> ■ Valuation number 1: Evaluation of the incremental or scanning track ■ Valuation number 3: <ul style="list-style-type: none"> ■ For absolute encoders: Evaluation of the absolute track ■ For incremental encoders: Evaluation of the reference pulse width or sum ■ Valuation number 4: Evaluation of position value formation/reference pulse position <ul style="list-style-type: none"> ■ For absolute encoders: Evaluation of position value formation ■ For incremental encoders: Evaluation of the reference pulse position ■ Valuation number 5: Evaluation of the battery voltage of touch probes ■ Valuation number 6: Evaluation of the transmission quality of touch probes

Display	Description
Mounting parameters	<p>Display of the mounting clearance (e.g., for rotary encoders without integral bearing)</p> <ul style="list-style-type: none"> ■ Mounting clearance: Distance at the current position ■ Minimum: Smallest distance in the traversed area ■ Maximum: Greatest distance in the traversed area ■ Current internal temperature: Measured value from the sensor in the encoder
<div style="background-color: #0070C0; color: white; padding: 5px; font-weight: bold;">NOTICE</div> <p>If the mounting parameters are not displayed although they are supported by the encoder, it may be necessary to activate them. The button with hammer and wrench is used for activation, see fig. 107</p> <ul style="list-style-type: none"> ■ To activate the mounting parameters, click the "Hammer + Wrench" icon <p>Further information: "", Page 226</p>	
Status – Absolute	<p>Status display of encoder errors and encoder warnings for the absolute value</p> <ul style="list-style-type: none"> ■ Green: No status message available ■ Red: Status message available <p>Further information: "Classification of the status messages", Page 198</p>
Status – Incremental	<p>Status display of encoder errors and encoder warnings for the incremental value</p> <p>Description see "Status – Absolute"</p>
Absolute position	<p>Absolute encoder position (position value 1)</p> <p>Unit: micrometers or degrees (depending on the encoder)</p> <p>For multiturn rotary encoders, the Adjusting and Testing Software in addition displays the number of revolutions</p>

Display	Description
Incremental position	Count value of incremental counter Unit: increments

i To see which valuation numbers the encoder supports, refer to the encoder configuration.
Further information: "Overview of supported valuation numbers", Page 264

i The **evaluation of the reference pulse sum** (valuation number 3) refers to the function reserve during the acquisition and evaluation of the reference pulse by the signal converter or the encoder. Thus, it does not evaluate the reference pulse itself (e.g., its position and width), but its entire evaluation function including the characteristic properties of the reference pulse and the signal converter or encoder. With the components "Incremental signal" and "Evaluation of the reference pulse sum", the online diagnostics thus allows for diagnosing during operation and supports regular functional checks.

i If a valuation number cannot be determined during operation, it is marked as invalid in the overview. A description of the possible causes can be found in the encoder documentation.

Bar graph

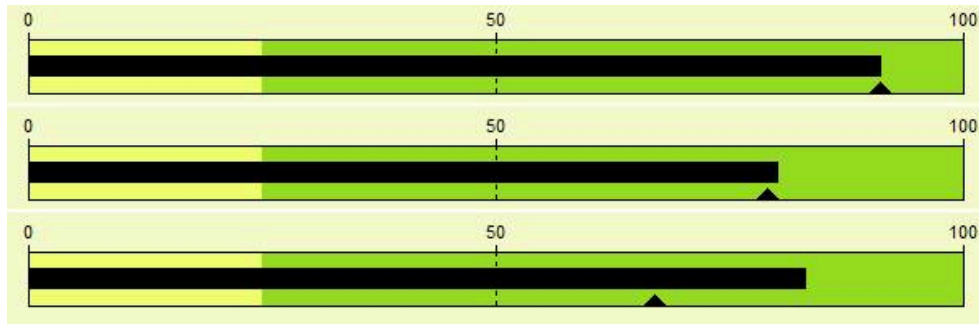

Figure 108: Bar graph of the **Online diagnostics** function

The bar display of the Adjusting and Testing Software shows each valuation number in a bar graph. The scale of the bar corresponds to the maximum function reserve of the encoder. The minimum, i.e. the smallest value within the traversed range, is determined for each valuation number. The drag indicator marks the minimum. The black bar shows the value transferred last.

The tolerance ranges are indicated by color in each bar graph:

Display	Function reserve	Description
Yellow	0 – 25 %	<ul style="list-style-type: none"> ■ Minimum is outside the specification ■ Encoder maintenance recommended
Green	26 – 100 %	<ul style="list-style-type: none"> ■ Minimum is within the specification ■ Encoder function reserves are sufficient

X/Y display

The X/Y display may be additionally available, depending on the encoder. It shows the course of the function reserves over the entire traverse path.

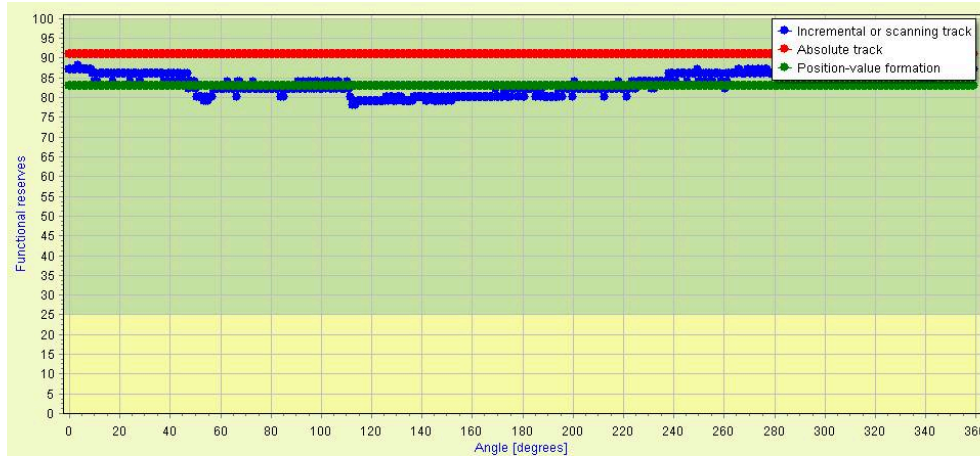















Figure 109: X/Y display of the **Online diagnostics** function

Depiction	Description
X axis	Position Input: millimeters or degrees (depending on the encoder)
Y axis	Function reserve

Operating elements

Icon	Function
	Start recording Starts recording of the measured values
	Stop recording Terminates recording and freezes the last view
	Show measured values Displays the measured value in increments
	Show position values Converts the measured value into a position value Unit: micrometers or degrees (depending on the encoder)
	Show status information Displays a list of errors and warnings
	Delete values Deletes the recorded values and resets the drag indicators to 100%
	Switch to bar display Shows the bar graphs
	Switch to X/Y display Shows the X/Y display
	Export data Opens the dialog for exporting records to a TXT file
	Save file Opens the dialog for saving the log to a PDF file
	Switch to Protocol view Shows the screen for entering log data
	Switch to Measurement view Shows the screen for running measurements
	Activate or deactivate mounting parameters The mounting parameters must be activated to be displayed.

11.7.2 Performing online diagnostics

Preconditions:

- The encoder was connected to the Adjusting and Testing Software by entering the encoder ID
- In the monitoring mode: The subsequent electronics supports the diagnostic function (request of diagnostic data); the diagnostic function is active in the subsequent electronics



- ▶ To call this function, double-click **Online diagnostics** in the function menu

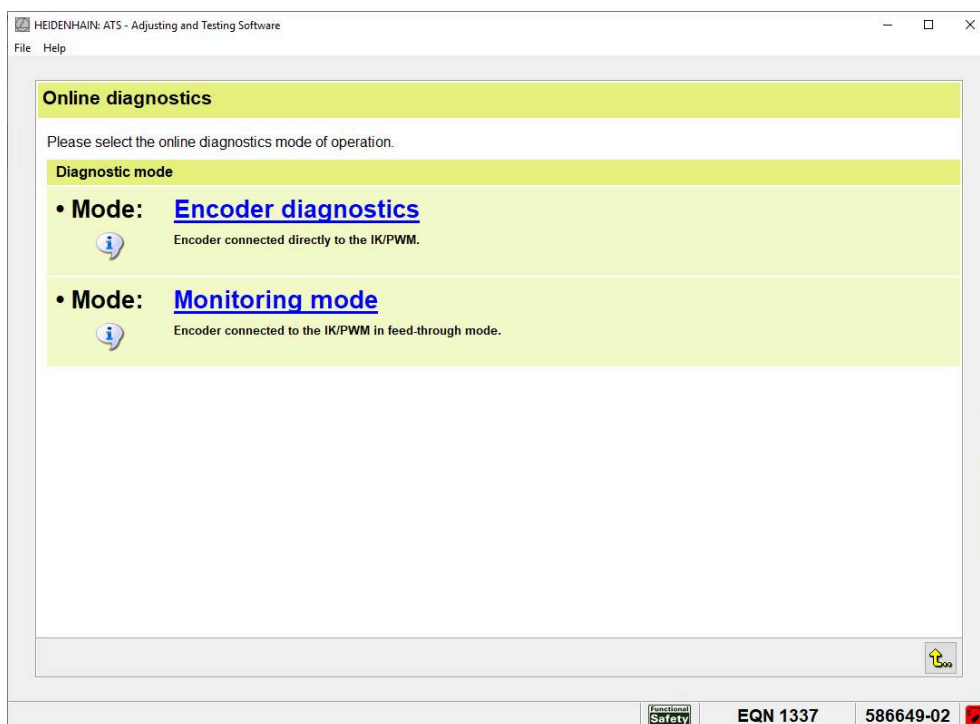

Figure 110: **Online diagnostics** function

- ▶ In the **Diagnostics mode** section, select the option that corresponds to the operating mode of the testing device:
 - Encoder diagnostics
 - Monitoring mode
- ▶ **Further information:** "Operating modes of the testing device", Page 26
- > The **Protocol** screen is shown

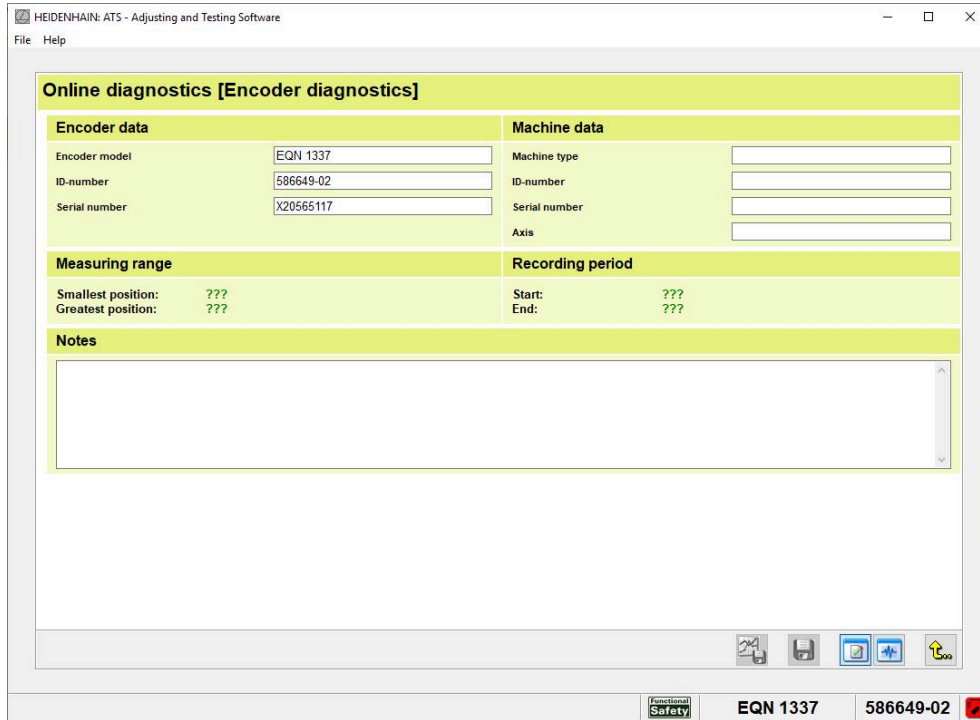

Figure 111: Protocol view of the Online diagnostics function

- ▶ Add log data, if necessary



- ▶ Click **Show measurement view** in the control bar
- ▶ The **Measurement** view shown

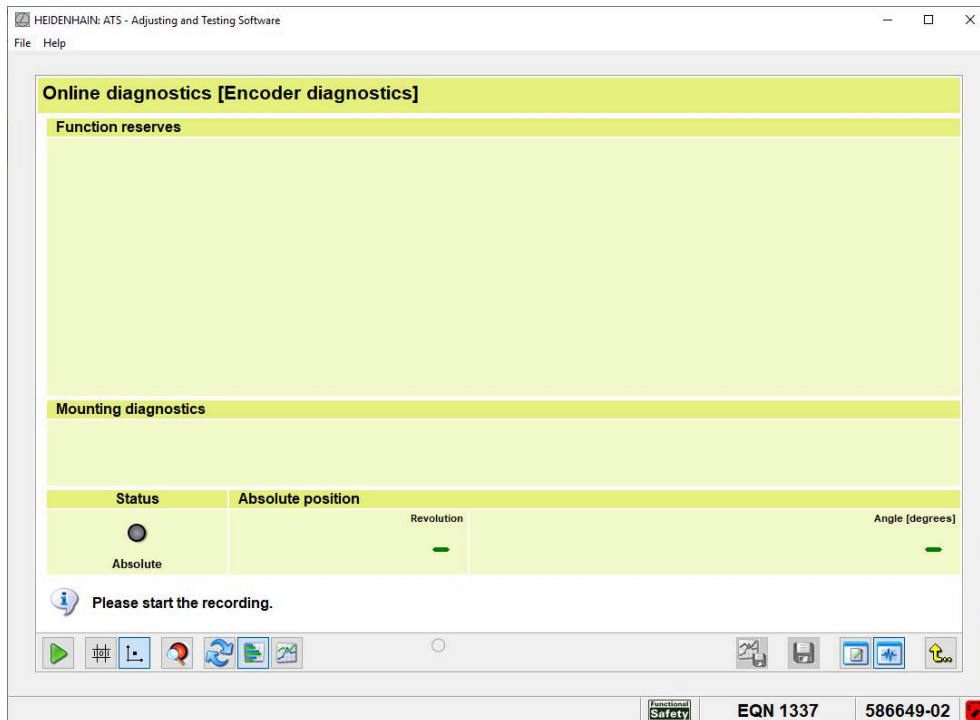

Figure 112: Measurement view of the Online diagnostics function

Running the measurement with bar display



- ▶ If necessary, click **Switch to bar display** in the control bar



- ▶ Click **Start measurement**
- ▶ Traverse the entire measuring range
- ▶ The valuation numbers are recorded
- ▶ The minimum is displayed for each valuation number



- ▶ Click **Terminate measurement**
- ▶ The displays show the last view

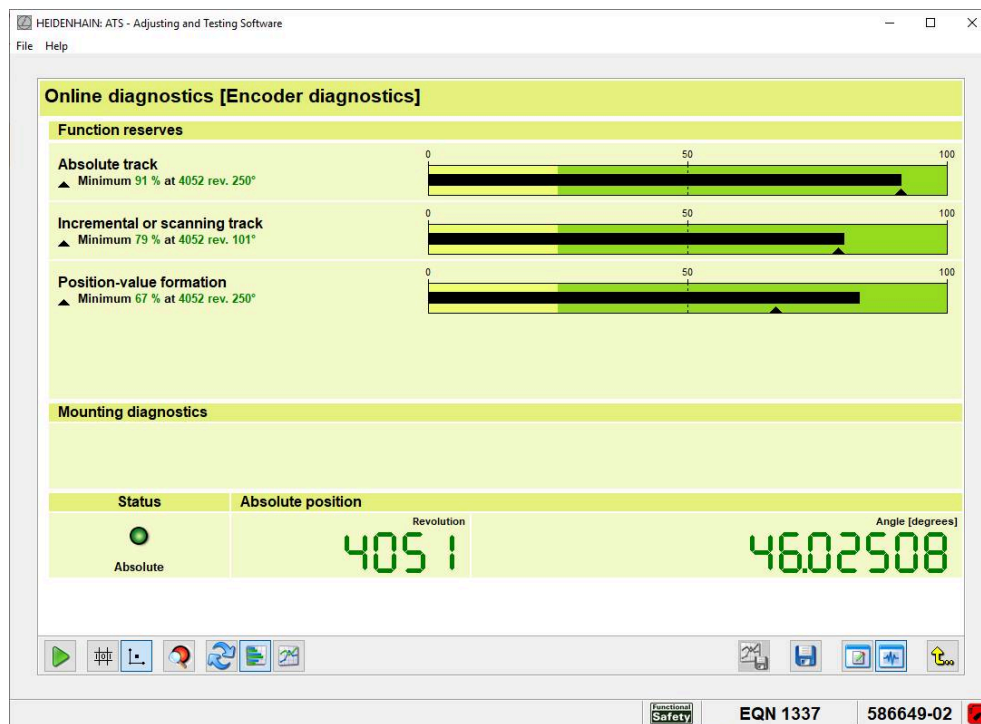

Figure 113: Result of the online diagnostics in the bar display



You can switch the counter display between measured values view and position view.

Further information: "Switching between measured values view and position view", Page 199



On the **Encoder status** screen, you can view status messages and delete them if necessary.

Further information: "Displaying status messages", Page 209



You can save the measuring result to a log file.

Further information: "Saving the log", Page 232

Running the measurement in the X/Y display

Precondition for incremental encoders: The encoder reference run has been completed; otherwise the X/Y display may show position jumps when reference marks are crossed over



- ▶ If necessary, click **Switch to X/Y display** in the control bar

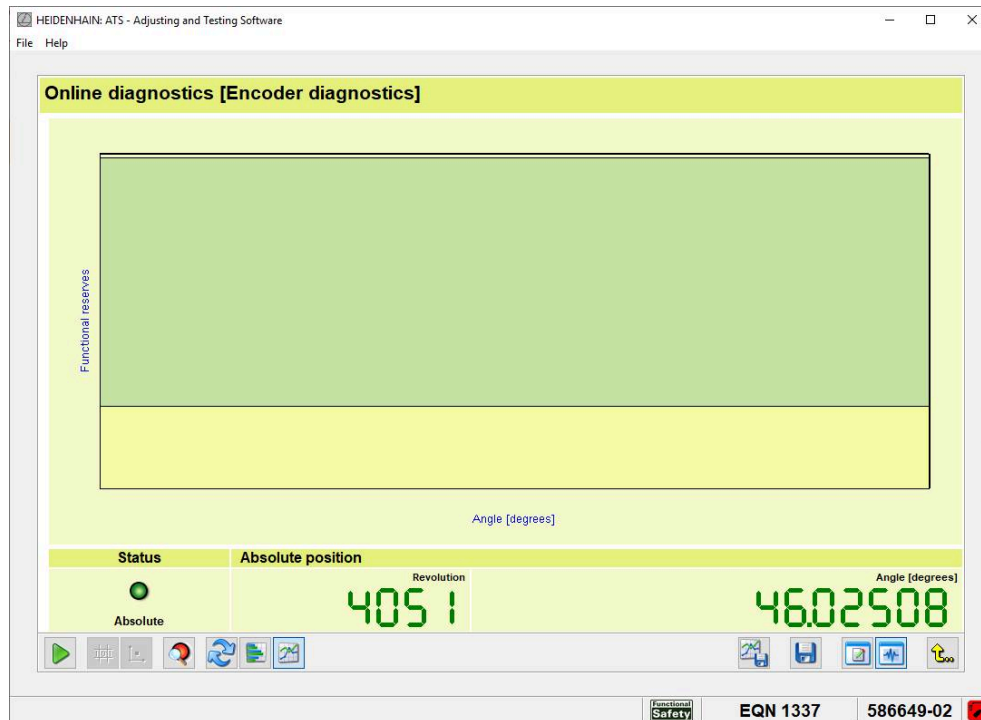

Figure 114: **Measurement** view with X/Y display



- ▶ Click **Start measurement**
- ▶ Traverse the entire measuring range
- > The valuation numbers are recorded
- > The diagram shows the function reserve at the respective position



- ▶ Click **Terminate measurement**
- > The displays show the last view

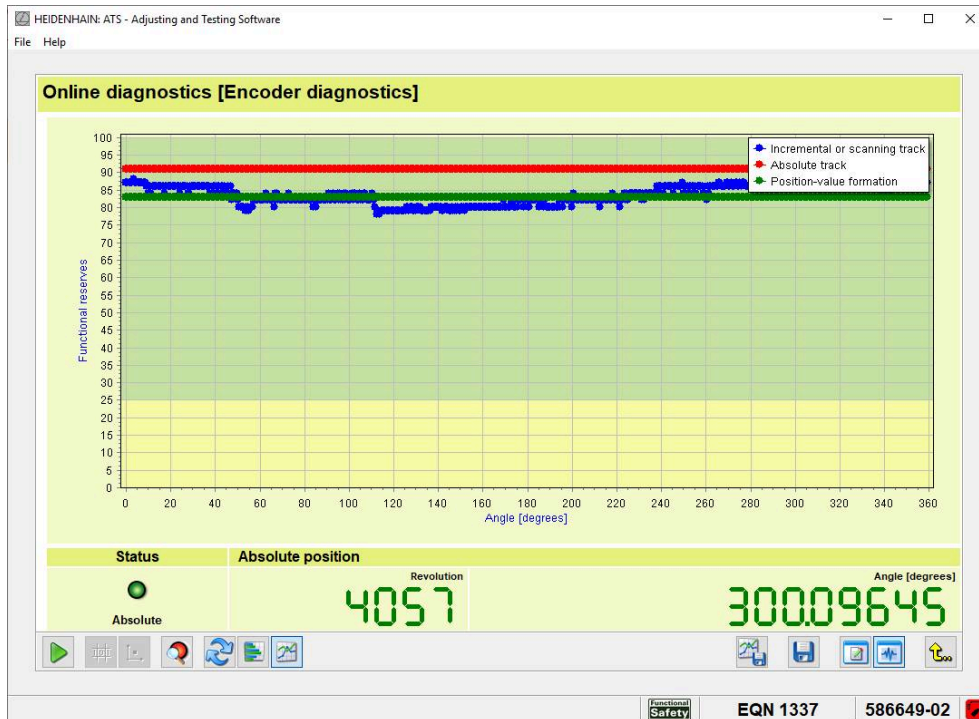

Figure 115: Result of the online diagnostics in the X/Y display

i If you position the mouse pointer on a point in the diagram, a mouseover text appears with brief information, e.g. the number of revolutions of a multiturn encoder.

i On the **Encoder status** screen, you can view status messages and delete them if necessary.

Further information: "Displaying status messages", Page 209

i You can export the data shown in the diagram to a TXT file.

Further information: "Exporting data", Page 232

i You can save and print the active diagram.

Further information: "Adjusting, exporting and printing diagrams", Page 48

i To examine a section more closely, you can zoom in on the diagram view.

Further information: "Magnifying the diagram view", Page 48

11.7.3 Saving the log

You can save the results of the online diagnostics in a PDF file.



- ▶ Click **Switch to Protocol view** in the control bar
- ▶ Complete the log data, if necessary



- ▶ Click **Save log**
- ▶ Select the desired storage location in the dialog
- ▶ Enter the file name
- ▶ Click **Save**
- > The input field **Comment in inspection report** is displayed
- ▶ If necessary, enter a comment
- ▶ Click **OK**
- > The file is saved



In the Adjusting and Testing Software, you can add an individual header and details on the examiner to the logs.

Further information: "Saving log information", Page 57



To display the PDF contents correctly, the font "Arial Unicode MS" must be installed on the computer.

11.7.4 Exporting data

You can save the recorded data to a TXT file.



- ▶ Click **Export data** in the control bar
- ▶ Select the desired storage location in the dialog
- ▶ Enter the file name
- ▶ Click **Save**
- > The file is saved

11.7.5 Deleting values

You can delete the recorded values to perform a new measurement.



- ▶ Click **Delete values** in the control bar
- > The **Minimum** value of each valuation number is deleted



The bar display is reset as soon as you start a new measurement.

11.8 Checking the functional safety of the encoder

11.8.1 Functional-safety encoder check

The functional-safety encoder check serves to check safety-relevant functions of encoders. A software wizard will guide you through the required steps.

Preconditions:

- The encoder supports the functional-safety encoder check
- The encoder was connected to the Adjusting and Testing Software by entering the encoder ID

 Encoders with Functional Safety can typically be identified by the word "Safety" printed on the ID label.

 If the functional-safety encoder check results in errors, the encoder does not comply with the functional safety specifications. Repairs may be carried out only by the HEIDENHAIN Service department.

 After installing and exchanging functional safety components, repeat the acceptance test according to the specifications of the machine tool builder.

Description of function:

The safety strategy of the position encoder is based on two mutually independent position values and additional error bits (error 1 and error 2) produced in the encoder and transmitted over the EnDat 2.2 protocol. The subsequent electronics compares the two position values and checks the error bits. In addition, the protocol structure of EnDat transmission provides the subsequent electronics with further monitoring information. The internal failure mechanisms of the encoder are also tested for proper functioning at specified intervals; this is called forced dynamic sampling.



- ▶ To call this function, double-click **Functional-safety encoder check** in the function menu
- > The dialog **Manual entry of measuring length** may be displayed (depending on the encoder)
- ▶ Enter the measuring length in millimeters
- ▶ Confirm the entry with **Accept**
- > The software wizard shows a list of the supported diagnostic functions

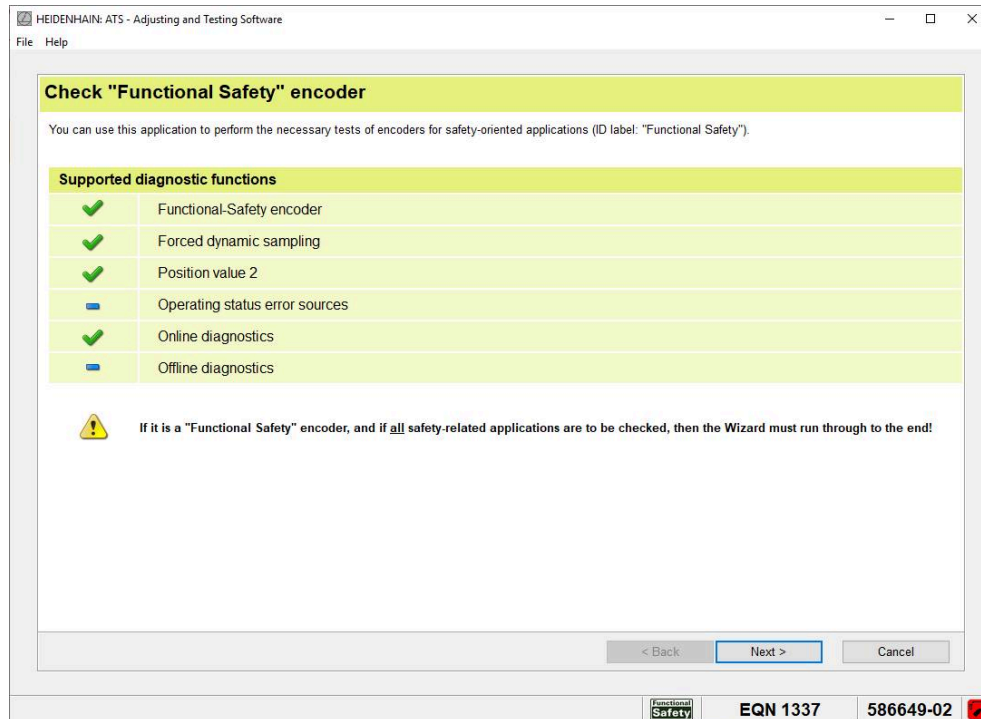

Figure 116: Overview of supported diagnostic functions

The overview shows the diagnostic functions the encoder supports.

Depiction	Description
	Functional-Safety encoder
	Forced dynamic sampling
	Position value 2
	Operating status error sources
	Online diagnostics
	Offline diagnostics

Icon	Description
	Diagnostic function is supported
	Diagnostic function is not supported; diagnostic function is not mandatory for the functional-safety encoder check
	Diagnostic function is not supported; functional-safety encoder check cannot be performed

Checking safety-relevant memory areas

The Adjusting and Testing Software checks the safety-relevant memory parameters for consistency with the encoder database.

- ▶ Click **Next** to check the safety-relevant memory areas
- > The Adjusting and Testing Software compares the memories
- > The software wizard shows the result of the comparison

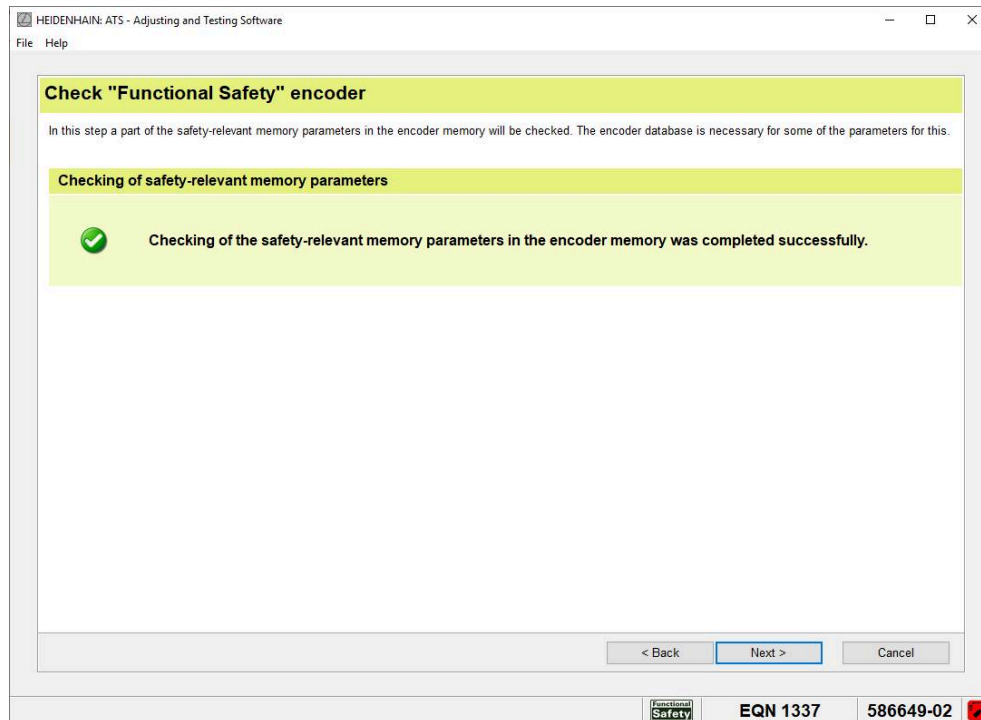

Figure 117: Result of the comparison of encoder memory and encoder database

- ▶ Click **Next** to continue
- > The software wizard shows information on **forced dynamic sampling**

Forced dynamic sampling

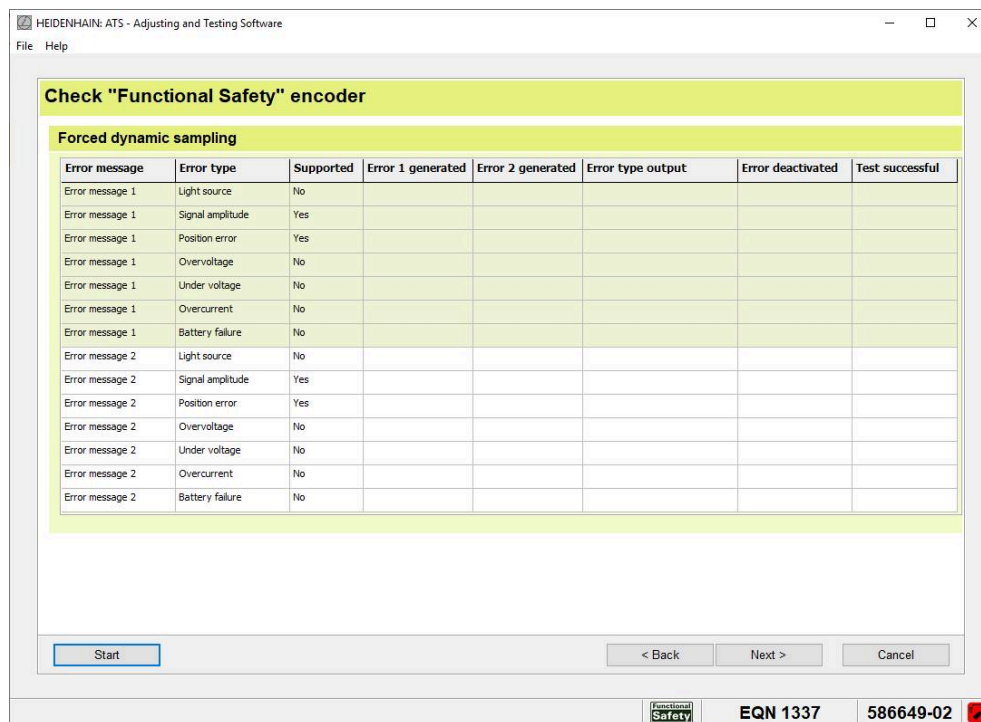

Figure 118: **Forced dynamic sampling** screen with supported error types

During forced dynamization, the internal failure mechanisms of the encoder are tested for proper functioning. The monitoring is divided into two groups (error message 1 and error message 2). Each group supports seven error types.

The table shows the error types the encoder supports. In forced dynamic sampling, the error types are stimulated individually and the response of the encoder is evaluated. Supported error types must generate a corresponding error 1 or error 2. Error types that are not supported must not generate an error when stimulated. The error type read out must correspond to the stimulated error type. Moreover, it must be possible to deactivate the error after stimulation.

- ▶ Click **Start** to start forced dynamic sampling
- > A message appears if error messages already exist
- ▶ Click **Yes** to confirm the deletion of existing error messages
- > Forced dynamic sampling is performed
- > The table contains the test result



Red entries in the table indicate faulty behavior of the encoder.

Inspecting encoders with serial interface (EnDat 2.1/EnDat 2.1, EnDat 2.2 and proprietary interfaces) | Checking the functional safety of the encoder

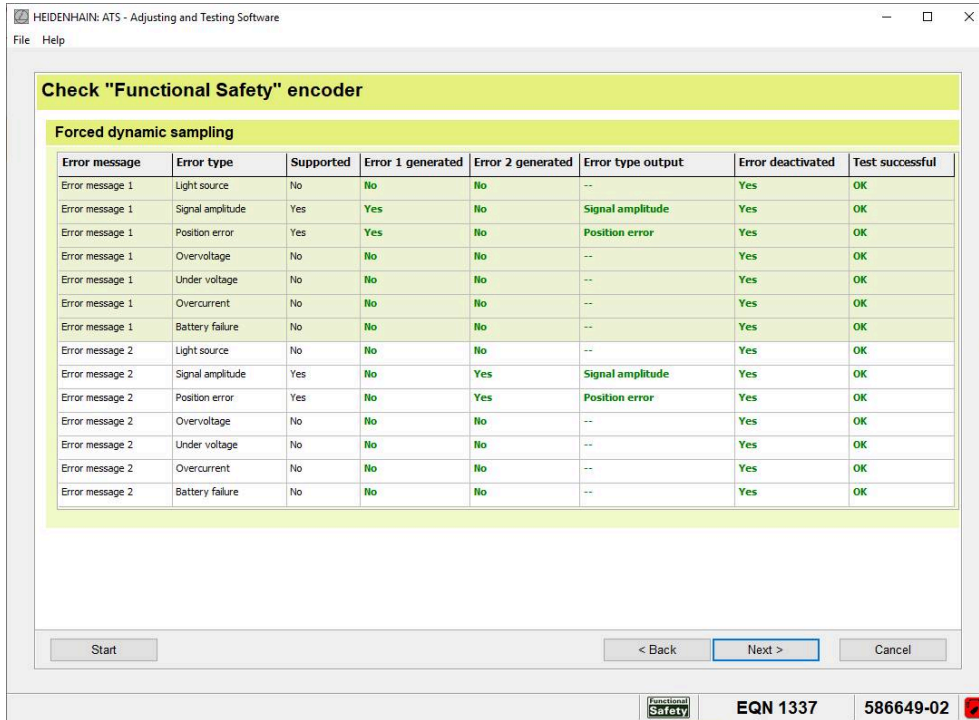

Figure 119: Result for correct behavior of the encoder

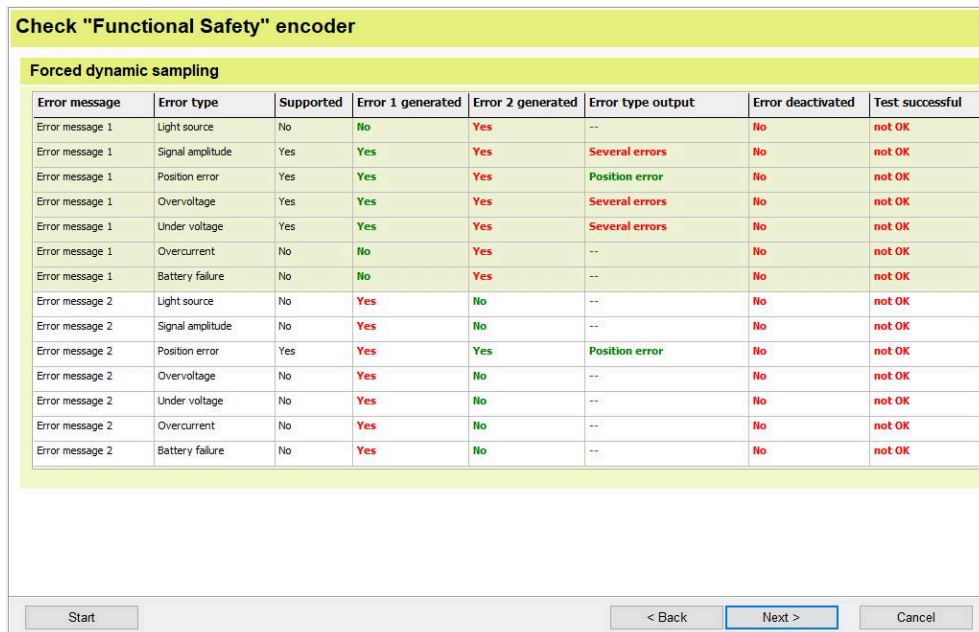

Figure 120: Result for faulty behavior of the encoder

- ▶ Click **Next** to continue
- > The software wizard shows information on the **test for consistency**

Test for consistency

Encoders supporting functional safety output two position values: the high-resolution position 1 and a lesser resolved position 2. During the test for consistency, the Adjusting and Testing Software scales the position value 1 to the resolution of position value 2 and checks position value 2 for consistency. The test is considered passed if the maximum position jump results in a deviation ≤ 3 .

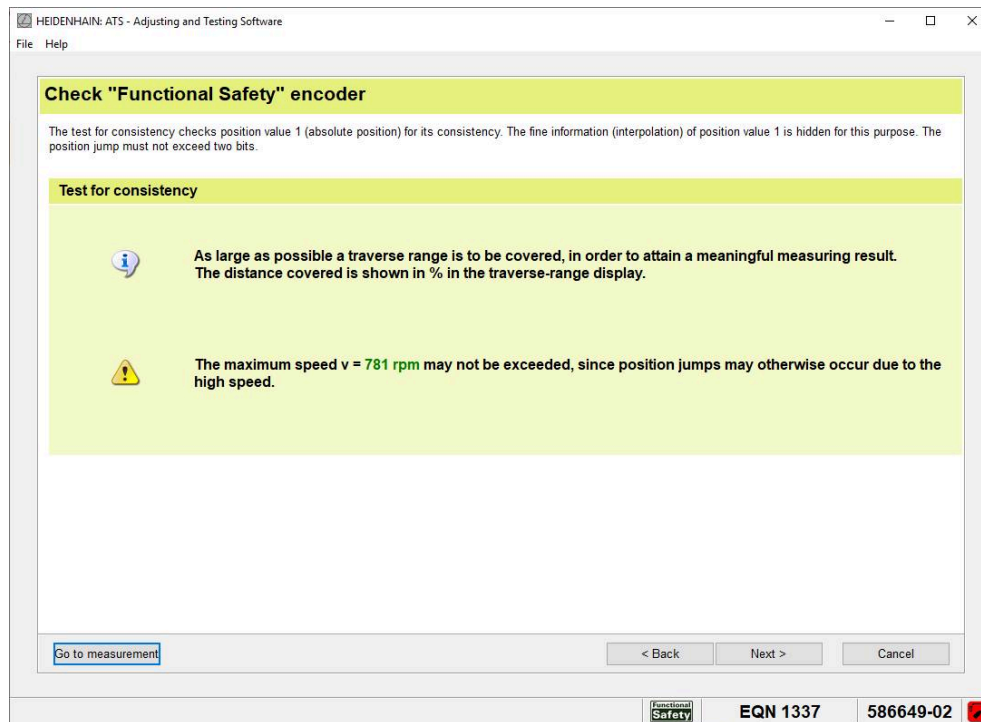

Figure 121: Information on the test for consistency

- ▶ Click **Go to measurement** to run the test for consistency
- > The **Measurement** screen is shown

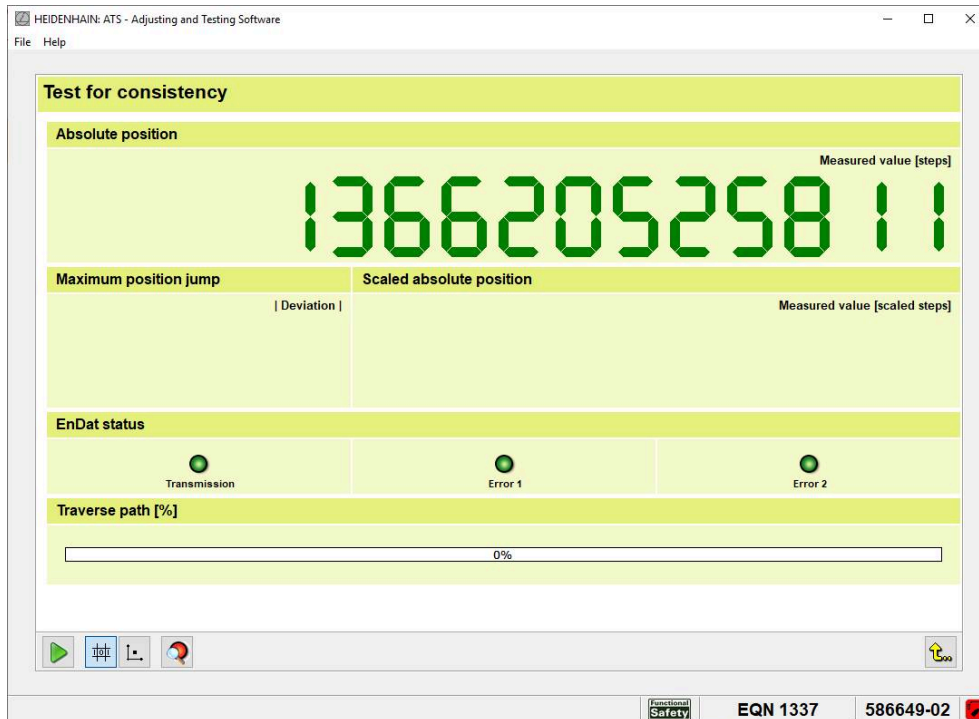







Figure 122: Measurement screen of the test for consistency

Depiction	Description
Absolute position	Absolute position 1 Unit: increments
Maximum position jump	Deviation of scaled position value 1
Scaled absolute position	Position value 1, scaled to resolution of position value 2
EnDat status	Status displays <ul style="list-style-type: none"> ■ Status display of data transfer between encoder and testing device (CRC test) <ul style="list-style-type: none"> ■ Green: No status message available ■ Red: Status message available ■ Error 1: Status display of the encoder error group 1 <ul style="list-style-type: none"> ■ Green: No status message available ■ Red: Status message available ■ Error 2: Status display of the encoder error group 2 <ul style="list-style-type: none"> ■ Green: No status message available ■ Red: Status message available
Traverse path	Traversed measuring distance in percent The traverse path is read out from the encoder memory or the encoder database (depending on the encoder).

Operating elements

Icon	Function
	Start recording Starts recording and evaluation of the measured values
	Stop recording Terminates recording and freezes the evaluation of the measured values
	Show measured values Displays the measured value in increments
	Show position values Converts the measured value into a position value Unit: micrometers or degrees (depending on the encoder)
	Show status information Displays a list of errors and warnings

- ▶ Click **Start measurement** in the control bar
- ▶ Traverse the entire measuring range
- > The progress bar shows the traversed distance in percent



The traverse path of encoders mounted to a machine may be limited such that the progress bar cannot reach 100%.

- ▶ Click **Terminate measurement**
- > The Adjusting and Testing Software shows the result of the test for consistency

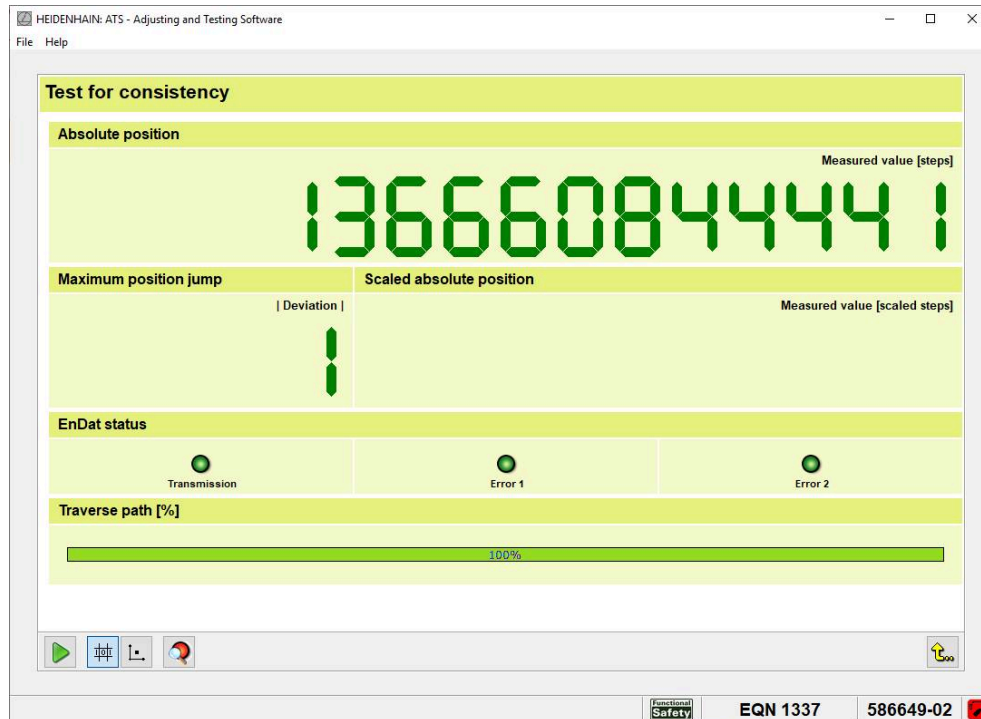

Figure 123: Result of the test for consistency



You can switch the counter display between measured values view and position view.

Further information: "Switching between measured values view and position view", Page 199



On the **Encoder status** screen, you can view status messages and delete them if necessary.

Further information: "Displaying status messages", Page 209



▶ Click **Return to last view** to return to the software wizard

▶ Click **Next** to continue

▶ The software wizard shows information on the **Comparison of position values**

Comparison of position values

The Adjusting and Testing Software scales the position value 1 to position value 2 and checks both position values. The position values must not differ by more than 1 bit. An active datum shift and other offset parameters are taken into account.

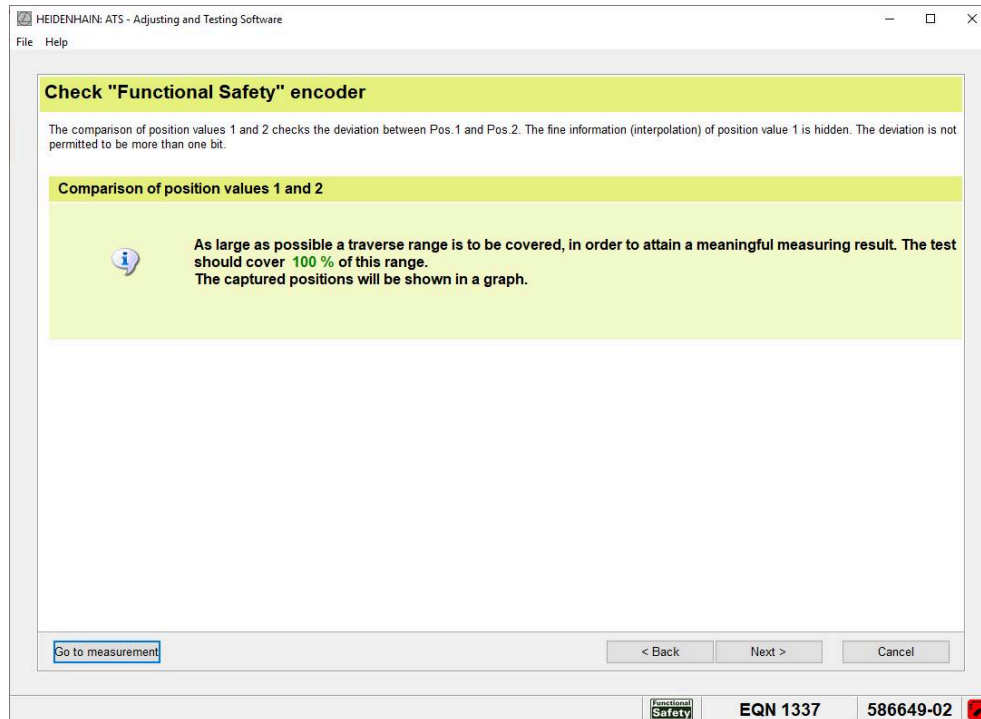

Figure 124: Information on comparison of position values

- ▶ Click **Go to measurement** to run the comparison of position values
- > The **Measurement** screen is shown

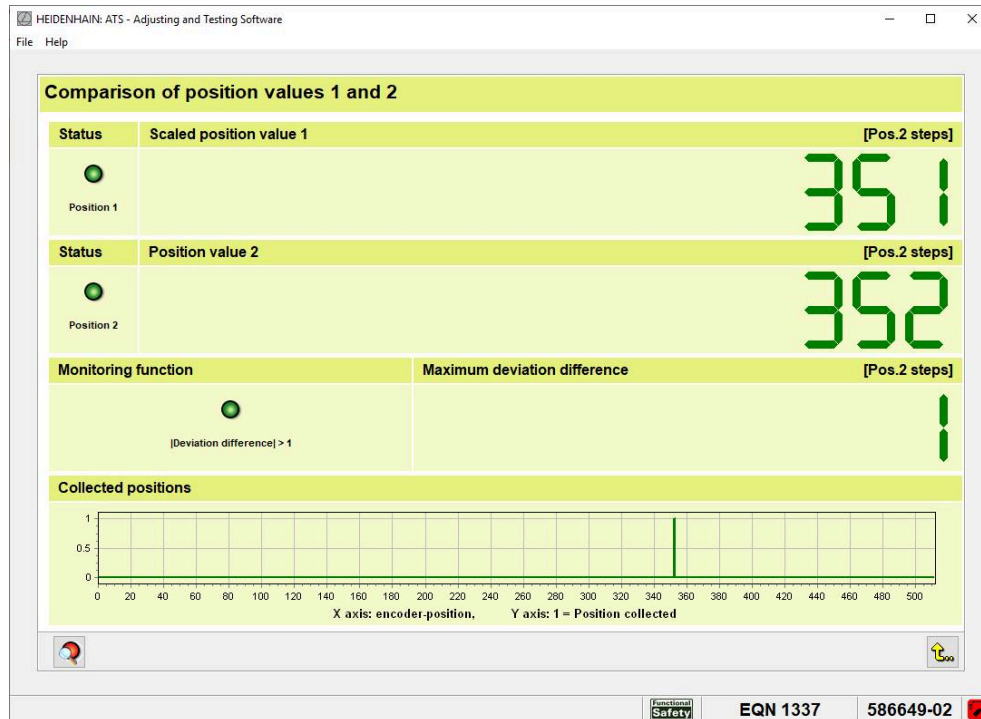

Figure 125: **Measurement** screen of the comparison of position values

Depiction	Description
Position 1	Status display of absolute position 1 The status display comprises the data transfer between the encoder and the testing device (CRC test) as well as the error group 1 and the error group 2. <ul style="list-style-type: none"> ■ Green: No status message available ■ Red: Status message available
Scaled position value 1	Position value 1, scaled to resolution of position value 2 Unit: increments
Position 2	Status display of absolute position 2 The status display comprises the data transfer between the encoder and the testing device (CRC test) as well as the error group 1 and the error group 2 <ul style="list-style-type: none"> ■ Green: No status message available ■ Red: Status message available
Position value 2	Position value 2 output by the encoder Unit: increments
Monitoring function	Status display of comparison of position values <ul style="list-style-type: none"> ■ Green: Maximum deviation ≤ 1 ■ Red: Maximum deviation > 1

Depiction	Description
-----------	-------------

Maximum deviation difference	Maximum deviation of the scaled position value 1 from position value 2
------------------------------	--



If the maximum deviation is > 1, the value is displayed in red color.

Collected positions diagram

The position values for the comparison of position values are captured by traversing the encoder. The Adjusting and Testing Software displays positions not yet captured as edges. Once all positions have been captured, a continuous line is displayed at Y = 1.

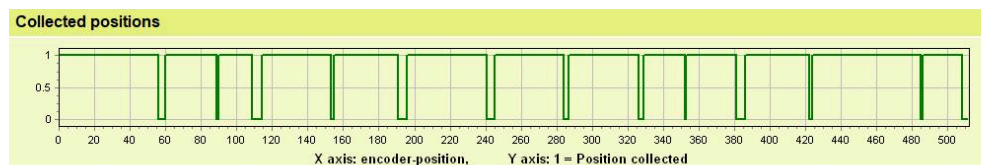

Figure 126: Collected positions diagram

Depiction	Description
-----------	-------------

X axis	Encoder position
Y axis	<ul style="list-style-type: none"> ■ Value 0 = Position not captured ■ Value 1 = Position captured

Operating elements

Icon	Function
------	----------



Show status information

Displays a list of errors and warnings

- ▶ Traverse the entire measuring range several times until the **Collected positions** diagram contains no more edges
- The Adjusting and Testing Software shows the **maximum deviation difference** of the collected position values

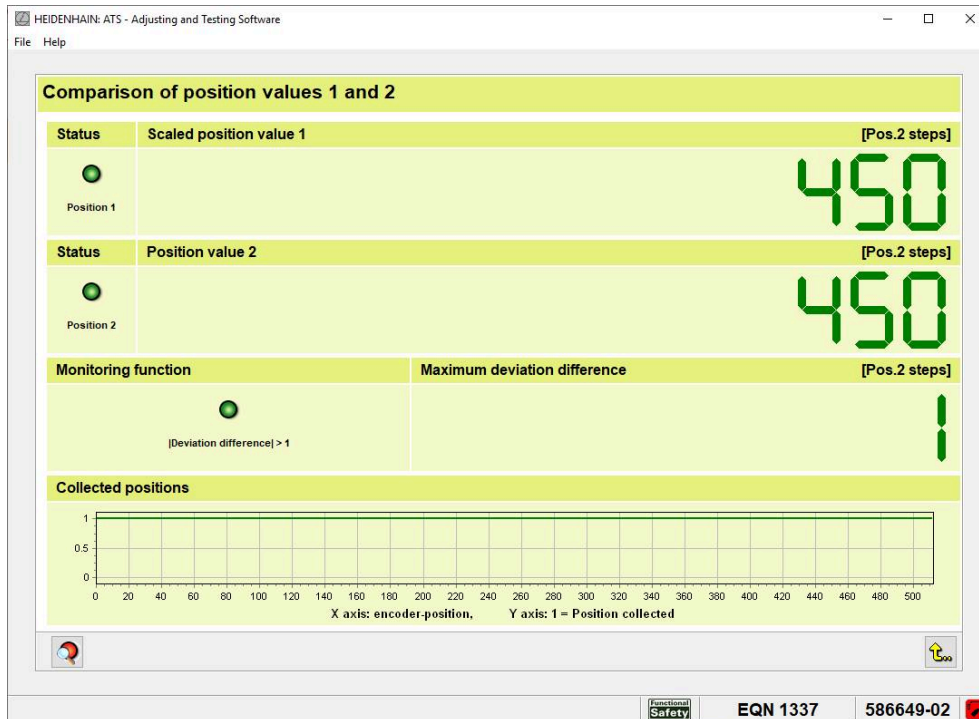

Figure 127: Result of comparison of position values

i The encoder is working correctly, if the determined deviation difference is no more than 1.

i On the **Encoder status** screen, you can view status messages and delete them if necessary.

Further information: "Displaying status messages", Page 209



- ▶ Click **Return to last view** in the control bar to return to the software wizard
- ▶ Click **Next** to continue
- ▶ The software wizard displays the results of the functional-safety encoder check

Results overview of the functional-safety encoder check

The overview shows the results of the functional-safety encoder check.

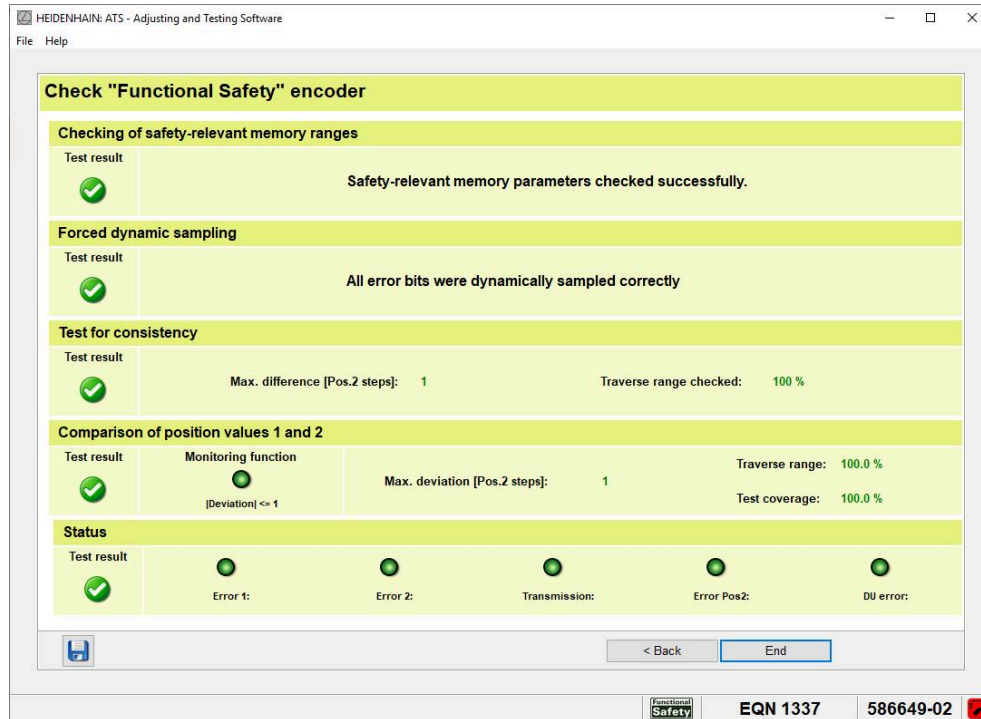



Figure 128: Results overview of the functional-safety encoder check





Red values or status displays indicate a malfunction of the encoder.

Depiction	Description
Checking of safety-relevant memory ranges	Result of memory comparison
Forced dynamic sampling	Result of forced dynamic sampling
	If the test returned errors, an overview of the error types concerned is displayed.
Test for consistency	Result of the test for consistency <ul style="list-style-type: none"> ■ Max. difference: Maximum deviation of scaled position value 1 ■ Traverse range checked: Measuring distance traversed during the test Unit: Percent

Depiction	Description
Comparison of position values	<p>Result of comparison of position values</p> <ul style="list-style-type: none"> Monitoring function: Status display of comparison of position values <ul style="list-style-type: none"> Green: Maximum deviation ≤ 1 Red: Maximum deviation > 1 Max. deviation: Maximum deviation of the scaled position value 1 from position value 2 Traverse range: Measuring distance traversed during the test Unit: Percent Test coverage: Position values captured in the traversed path Unit: Percent <div style="border: 1px solid black; padding: 5px; margin-top: 10px;"> <p> If the captured area is less than 5%, the result is displayed in red. However, for an evaluation of the encoder in the specific application, the maximum traversing range needs to be examined.</p> </div>

Status	<p>Status displays:</p> <ul style="list-style-type: none"> Error 1: Error group 1 Error 2: Error group 2 Transmission: Data transfer between encoder and testing device (CRC test) Error Pos2: Error of position value 2 DU error: Internal safety-relevant encoder errors <p>Status:</p> <ul style="list-style-type: none"> Green: No status message available Red: Status message available
--------	--

The symbol in column 1 indicates whether and with which result a test was performed.

Icon	Description
	<ul style="list-style-type: none"> Test performed Test completed without error
	<ul style="list-style-type: none"> Test not performed <p>or</p> <ul style="list-style-type: none"> Test found errors

Operating elements

Icon	Function
	<p>Save file</p> <p>Opens the dialog for saving the log to a TXT file</p>

Procedure in the event of errors

If the functional-safety encoder check returns errors, proceed as follows:

- ▶ Abort the functional-safety encoder check
- ▶ Reset status messages
Further information: "Resetting status messages", Page 211
- ▶ Repeat the functional-safety encoder check
- ▶ If errors are found again, contact the HEIDENHAIN Service

11.8.2 Saving the log

You can save the results of the functional-safety encoder check in a PDF file.



- ▶ Click **Save log** in the control bar
- ▶ Select the desired storage location in the dialog
- ▶ Enter the file name
- ▶ Click **Save**
- > The file is saved



In the Adjusting and Testing Software, you can add an individual header and details on the examiner to the logs.

Further information: "Saving log information", Page 57



To display the PDF contents correctly, the font "Arial Unicode MS" must be installed on the computer.

11.9 Loading and editing the encoder configuration

Encoders with EnDat interface feature an internal encoder memory. You can access the encoder memory via the Adjusting and Testing Software. Thus you have the following options:

- Load encoder configuration from encoder
- Save encoder configuration to a file
- Load encoder configuration from a file
- Edit encoder configuration and transfer it to the encoder



A detailed description of the memory areas and data words can be found in the document "Bidirectional synchronous serial interface for position encoders" with the document ID D297403 (available on request).

11.9.1 Display encoder memory function

With the **Display encoder memory** function you can load the encoder configuration from the connected encoder to the Adjusting and Testing Software and navigate in the folder structure.



- ▶ To call this function, double-click **Display encoder memory** in the function menu

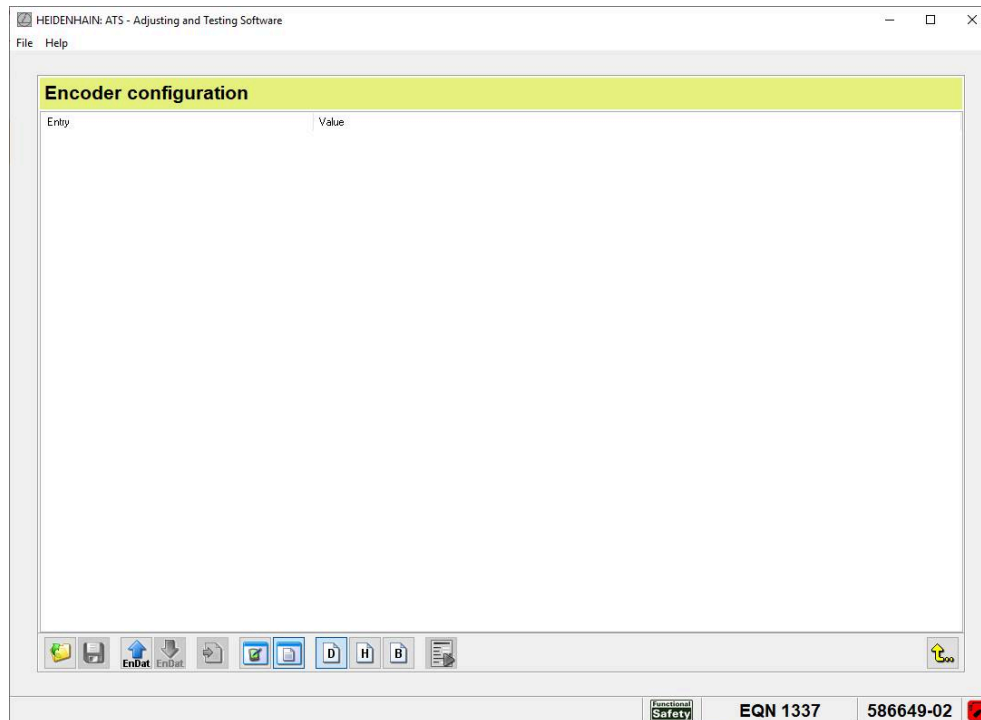













Figure 129: **Display encoder memory** function

Operating elements

Icon	Function
	<p>Load file</p> <p>Opens the dialog for selecting the file containing the encoder configuration</p>
	<p>Save file</p> <p>Opens the dialog for saving the encoder configuration to an ECF file</p>
	<p>Load encoder memory</p> <p>Starts the export of the encoder memory</p>
	<p>Save in encoder</p> <p>Opens the dialog for overwriting selected memory areas in the encoder</p>
	<p>Close all folders</p> <p>Reduces folder display to the first level</p>
	<p>Display functions</p> <p>Shows the encoder data in functions</p>
	<p>Display data words</p> <p>Displays the encoder data in data words</p>
	<p>Decimal format</p> <p>Shows numerical values in decimal format</p>
	<p>Hexadecimal format</p> <p>Shows numerical values in hexadecimal format</p>
	<p>Binary format</p> <p>Shows numerical values in binary format</p>
	<p>Save encoder information</p> <p>Opens the dialog for saving the encoder information to a TXT file</p>

11.9.2 Loading the encoder configuration from the encoder memory



- ▶ Click **Load encoder memory** in the control bar
- > The encoder memory is read out
- > The folder structure of the encoder configuration is displayed

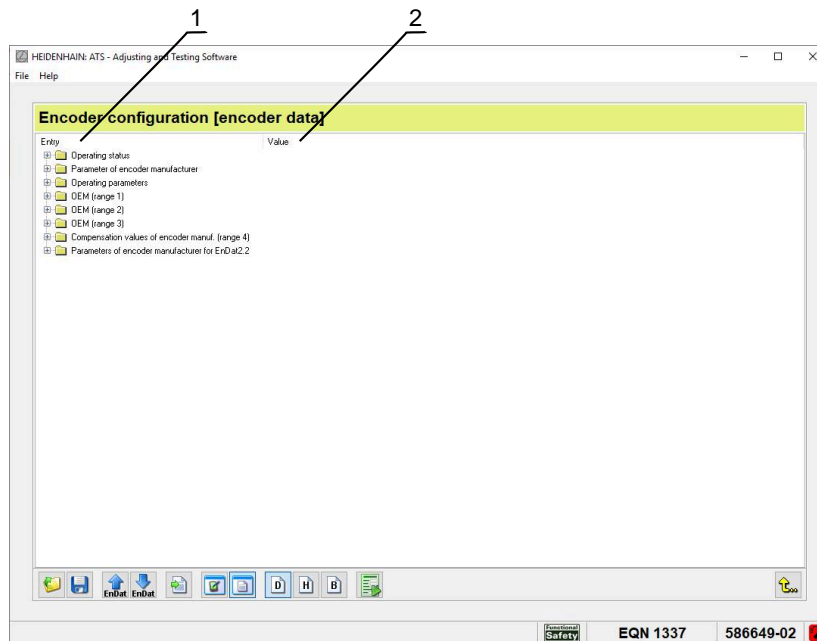



Figure 130: Folder structure of the encoder configuration for EnDat 2.2 interface (example)

- 1 Entry: Memory areas
- 2 Value: Values assigned to the memory area

 The folder structure depends on the connected encoder.

11.9.3 Adapting the encoder configuration view

Switching between data view and functions view

In the **Encoder configuration** function you can switch between the following views:

- **Data view**
- **Function view**

Data view

The Adjusting and Testing Software shows the memory contents in data words (image of the encoder memory).

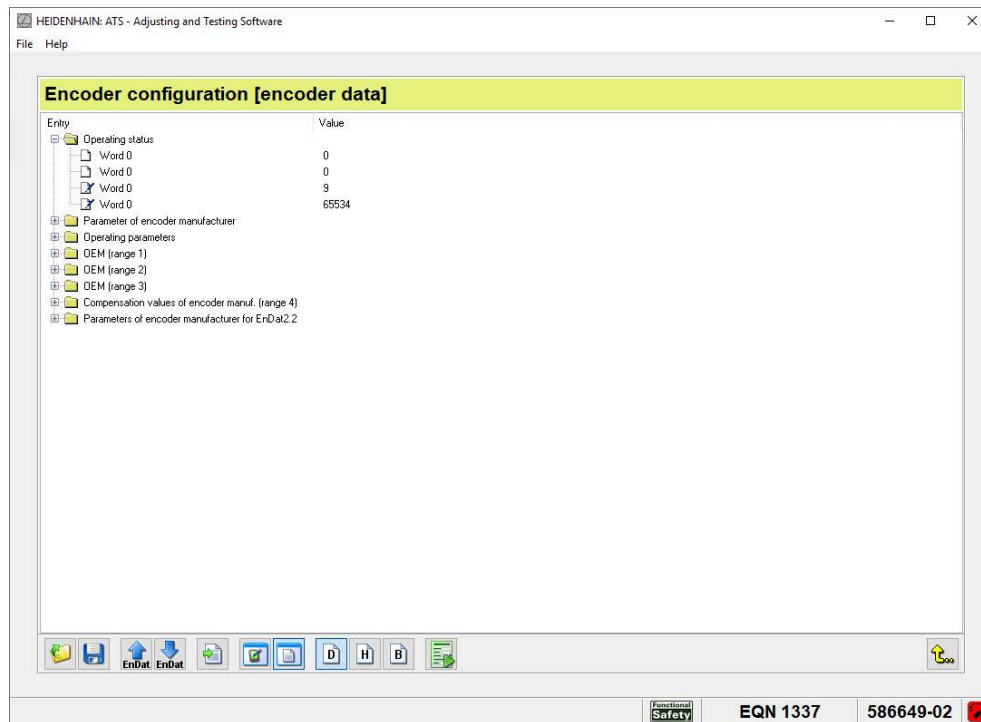

Figure 131: Data view

Function view

The Adjusting and Testing Software interprets the data words according to the EnDat specification and assigns functions to the memory contents.

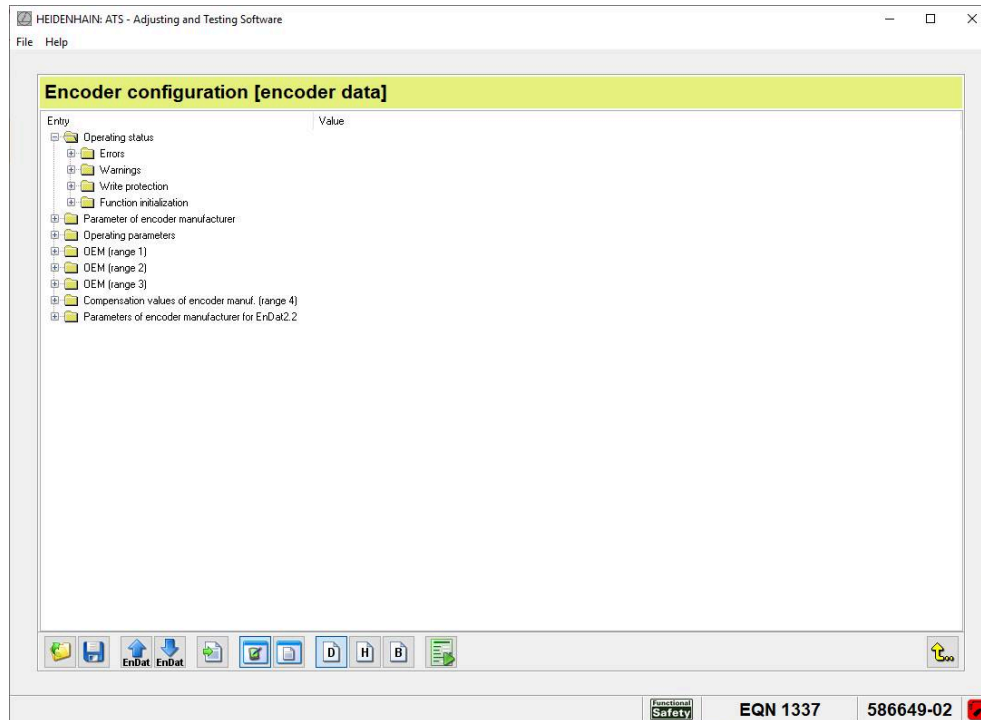

Figure 132: Function view

Switching between the views

When the **Display memory contents** function is called, the data view is displayed.



- ▶ Click **Display functions** in the control bar to switch to the function view



- ▶ Click **Display data words** in the control bar to return to the data view

Adjusting the number format

You can choose between different number formats for displaying numerical values.



- ▶ Click **Decimal format** in the control bar to display numerical values in decimal format



- ▶ Click **Hexadecimal format** in the control bar to display numerical values in hexadecimal format



- ▶ Click **Binary format** in the control bar to display numerical values in binary format

Closing all folders

You can reduce the folder structure to the top level in the **Encoder configuration** function.



- ▶ Click **Close all folders** in the control bar
- ▶ The folder structure is reduced to the top level

11.9.4 Saving the encoder configuration to a file

If you have loaded an encoder configuration in the Adjusting and Testing Software you can save this configuration in an ECF file. You can then open this file again in the Adjusting and Testing Software and transfer the data to the encoder.



- ▶ Click **Save file** in the control bar
- ▶ Select the desired storage location in the dialog
- ▶ Enter the file name
- ▶ Click **Save**
- > The file is saved

11.9.5 Saving encoder information to a file

You can save important information on the connected encoder—such as serial number, length of measuring step, datum shift—in a TXT file. Which information the TXT file comprises depends on the encoder.



- ▶ Click **Save encoder information** in the control bar
- ▶ Select the desired storage location in the dialog
- ▶ Enter the file name
- ▶ Click **Save**
- > The file is saved

11.9.6 Loading the encoder configuration from a file

You can load an encoder configuration from an ECF file in the Adjusting and Testing Software.





- ▶ Click **Load file** in the control bar
- ▶ Select the storage location of the file
- ▶ Click **Open**
- > The encoder configuration is loaded from the file
- > The folder structure of the encoder configuration is displayed
- > The file name is shown in the title bar

11.9.7 Editing the encoder configuration

You can edit individual values in the displayed encoder configuration. Afterwards you can transfer the changed encoder configuration to the encoder.

The document symbol in the line indicates whether a value can be edited:

Display	Description
	Value can be edited
	Value cannot be edited
	Value cannot be edited; the data word is the result of a calculation or consists of several data words (e.g., ID 557650-06)



Memory areas may be write-protected. You will find an overview of the write-protected memory areas in the encoder configuration.

Further information: "Overview of write-protected memory areas", Page 263

Editing values

WARNING

Danger of uncontrolled axis movements due to datum shift

Overwriting the "Zero point" value in the encoder memory can cause uncontrolled movements of the machine axes. This may result in death, serious injuries, or damage to equipment.

- ▶ Only execute datum shifts in the **Position display** function
- ▶ Do not manually change the "Zero point" value in the encoder configuration

Editing numerical values

- ▶ Click the value
- > The input field is activated
- ▶ Enter the desired value
- ▶ Confirm with **Enter**
- > The new value is shown in the encoder configuration

or

- ▶ Click the value
- > The input field is activated
- ▶ Click **Edit** next to the input field
- > The editing window is displayed

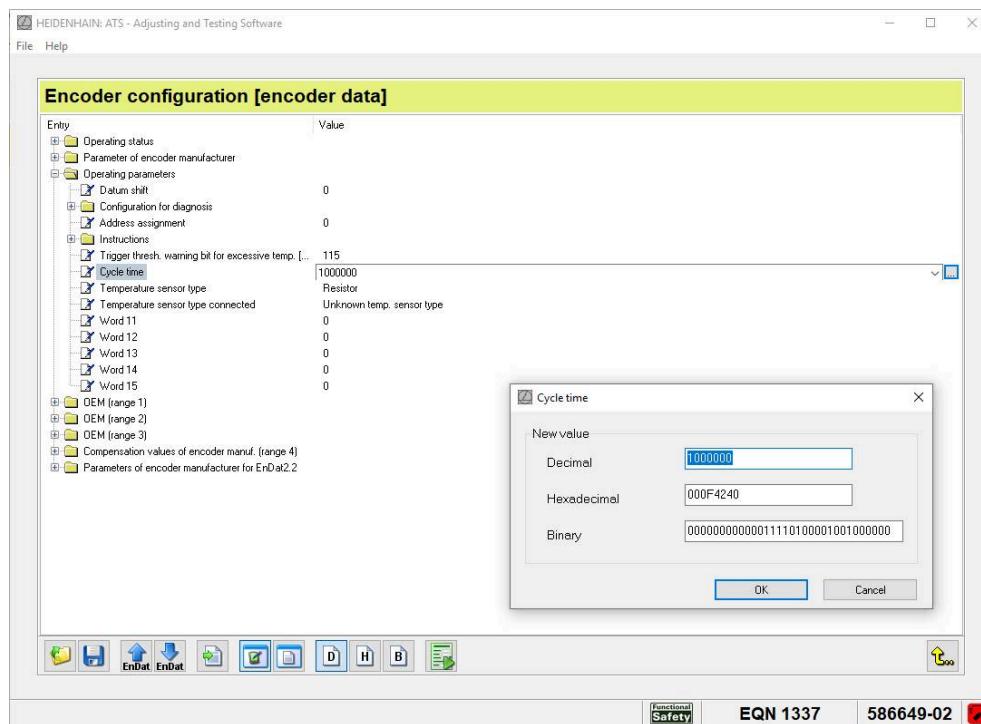
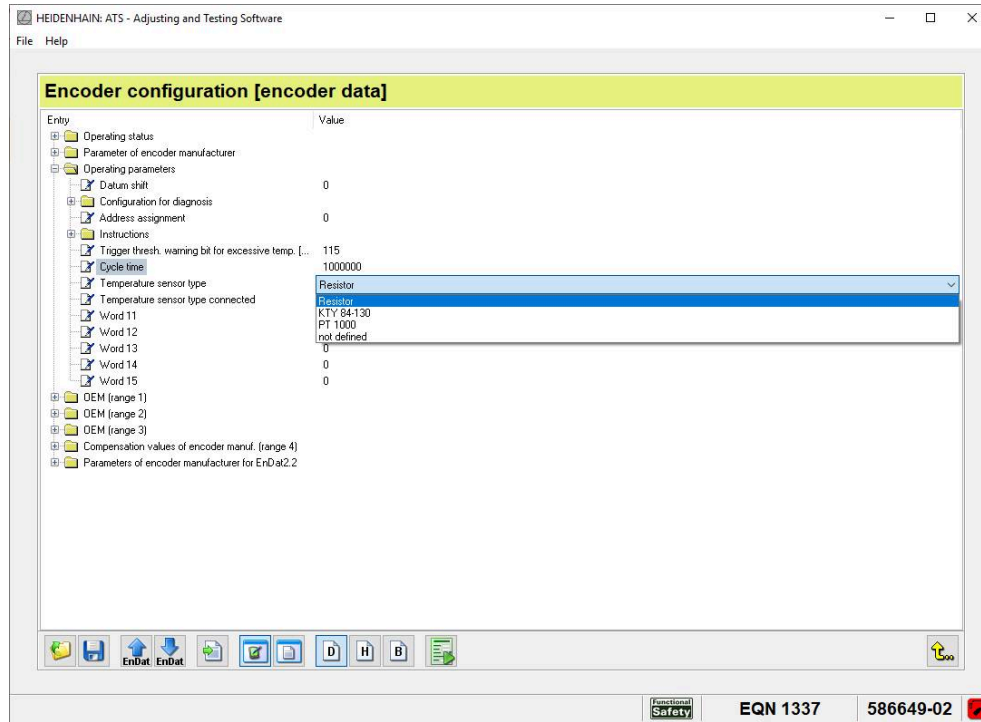

Figure 133: Encoder configuration with editing window

- ▶ Enter the value in one of the following number formats in the corresponding field
 - Decimal
 - Hexadecimal
 - Binary
- ▶ Confirm with **OK**
- > The new value is shown in the encoder configuration

Editing text values

- ▶ Click the value
- ▶ Select the desired value from the drop-down list
- ▶ The new value is shown in the encoder configuration



Editing yes/no values

- ▶ Click the value
- A check box is displayed instead of the value
- ▶ Check the box to select the value "Yes"
- ▶ Remove the tick from the checkbox to select "No"
- ▶ Confirm with **Enter**
- The new value is shown in the encoder configuration

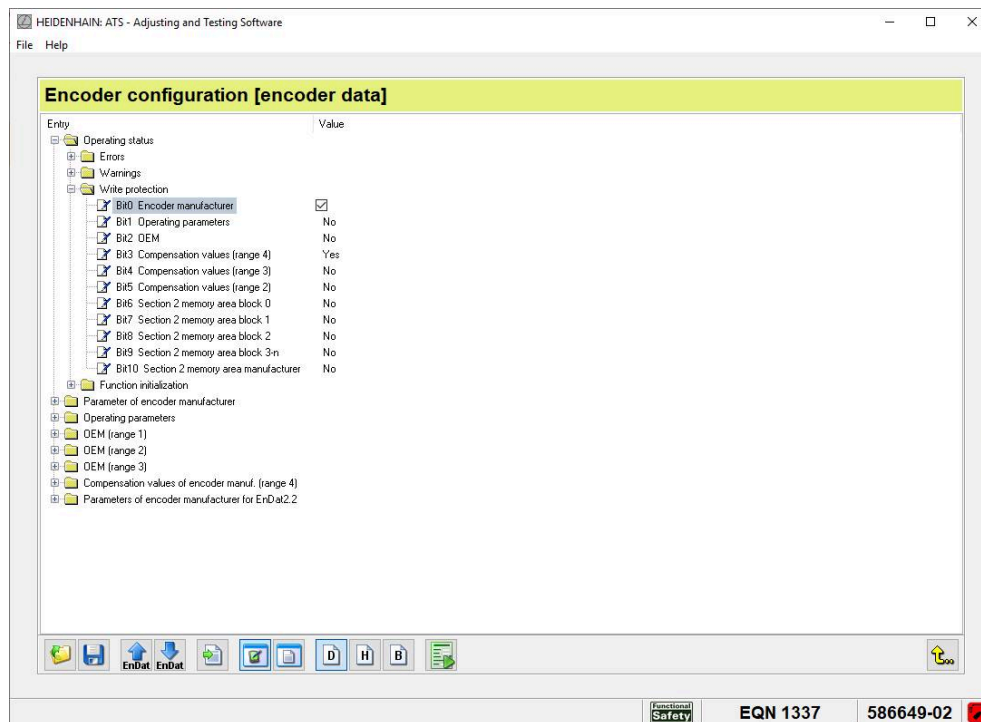

Afterwards you can transfer the changed encoder configuration to the encoder or save it to a file.

Further information: "Saving the encoder configuration in the encoder",
Page 260

Further information: "Saving the encoder configuration to a file",
Page 254

Setting write-protection

To prevent machine-relevant parameters from being changed, you can assign write protection to individual memory areas. This is necessary, particularly to ensure machine safety and system reliability.

The **Parameters of encoder manufacturer** memory area is write-protected by default.



Write protection can only be canceled by the HEIDENHAIN Service.



- ▶ Click **Load encoder memory** in the control bar
- The encoder memory is read out
- The folder structure of the encoder configuration is displayed
- ▶ Navigate to the **Write protection** folder
Path: **Operating status** ▶ **Write protection**

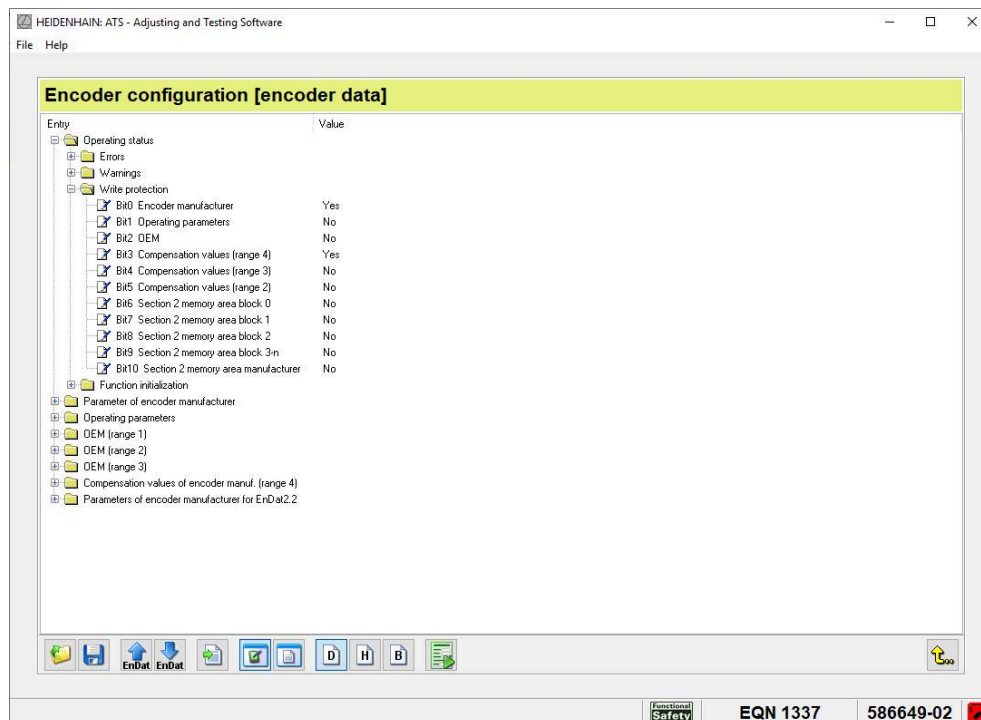

Figure 134: Function view with **Write protection** folder

- ▶ Click the value "No" in the line of the desired memory area
- A check box is displayed instead of the value
- ▶ Check the box to select the value "Yes"
- ▶ Confirm with **Enter**
- ▶ To activate write protection in the encoder, save the changed encoder configuration in the encoder
Further information: "Saving the encoder configuration in the encoder", Page 260

Saving the encoder configuration in the encoder

You can use the Adjusting and Testing Software to overwrite memory areas of the encoder, for example to restore the default configuration using a backup file.



- ▶ Click **Load file** in the control bar to load the encoder configuration you wish to save in the encoder
- ▶ Select the storage location of the file
- ▶ Click **Open**
- > The encoder configuration is loaded from the file
- > The folder structure of the encoder configuration is displayed



- ▶ Click **Save in encoder** to transfer the displayed encoder configuration to the encoder
- > The **Selection of memory area** dialog appears
- ▶ Select the memory areas you want to overwrite
- ▶ Click **Transfer**
- > The encoder configuration is transferred to the encoder
- > The selected memory areas are overwritten



Memory areas may be write-protected. You will find an overview of the write-protected memory areas in the encoder configuration.

Further information: "Overview of write-protected memory areas", Page 263

11.9.8 Overviews

Below you will find some example overviews of the encoder configuration.

Overview of supported error messages and warnings

The encoder configuration provides an overview of the error messages and warnings the encoder supports.

Path to the overview of the error messages:

Parameters of the encoder manufacturer ► Support of error messages

Path to the overview of the warnings:

Parameters of the encoder manufacturer ► Support of warnings

Supported error messages and warnings are identified by the value "Yes".

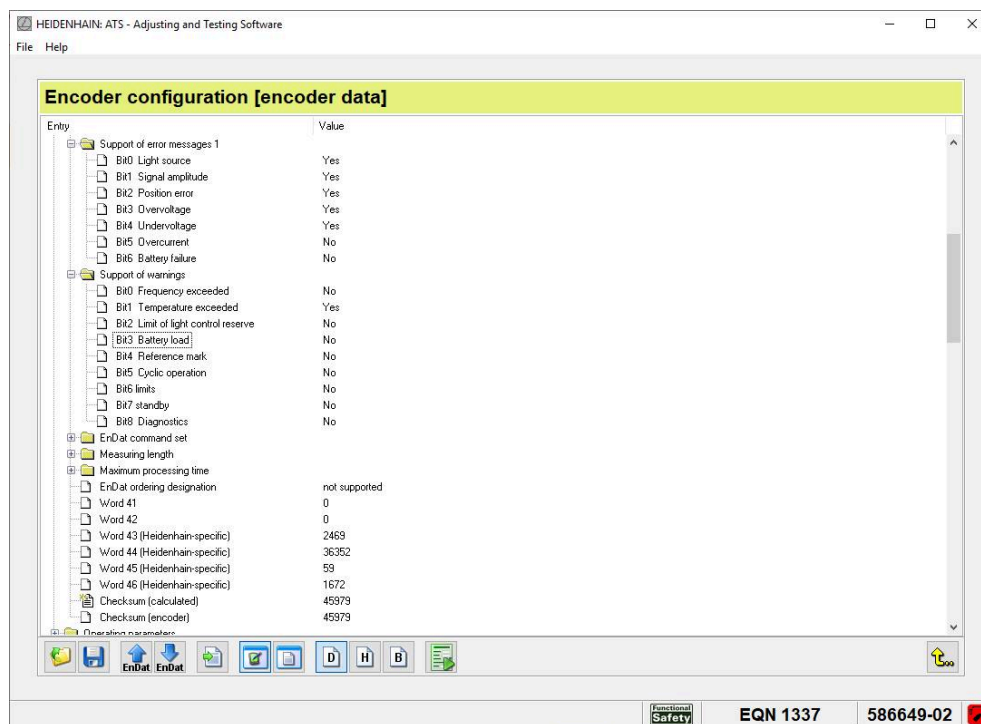

Figure 135: Function view with the folders **Support of error messages** and **Support of warnings**

Overview of supported operating status error sources

The encoder configuration of encoders with EnDat 2.2 interface provides an overview of the operating status error sources the encoder supports.

Path: **Parameters of the encoder manufacturer ▶ Manufacturer parameters EnDat 2.2 ▶ Support of operating status error sources**

Supported operating status error sources are identified by the value "Yes".

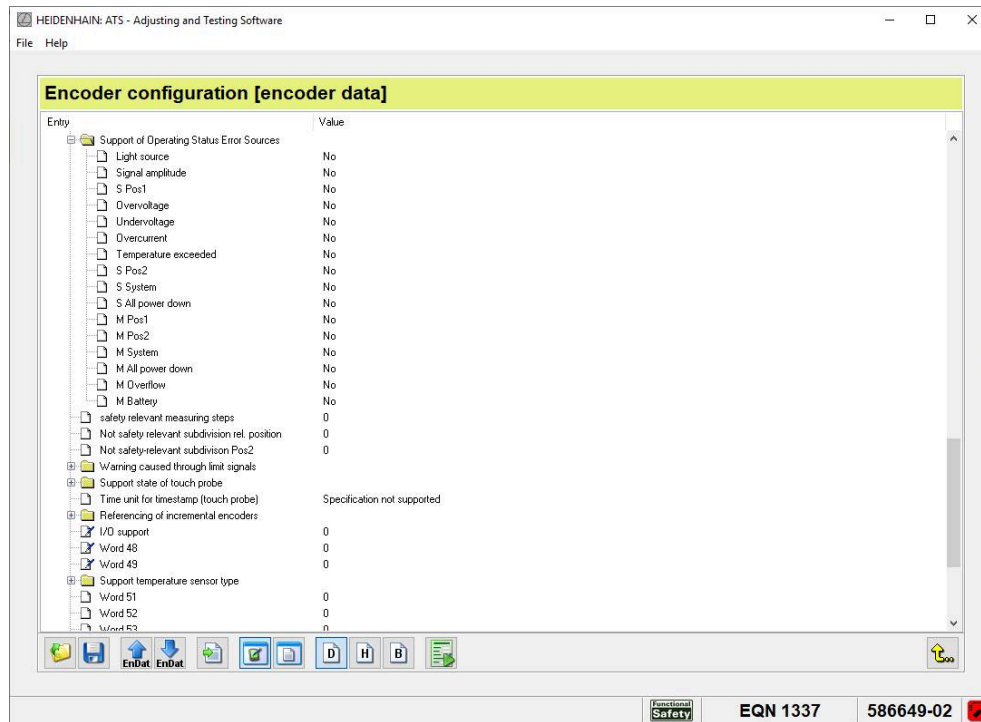

Figure 136: Function view with the folder **Support of operating status error sources**

Overview of write-protected memory areas

The encoder configuration provides an overview of the write-protected memory areas.

Path: **Operating status** ► **Write protection**

Write-protected memory areas are identified by the value "Yes".

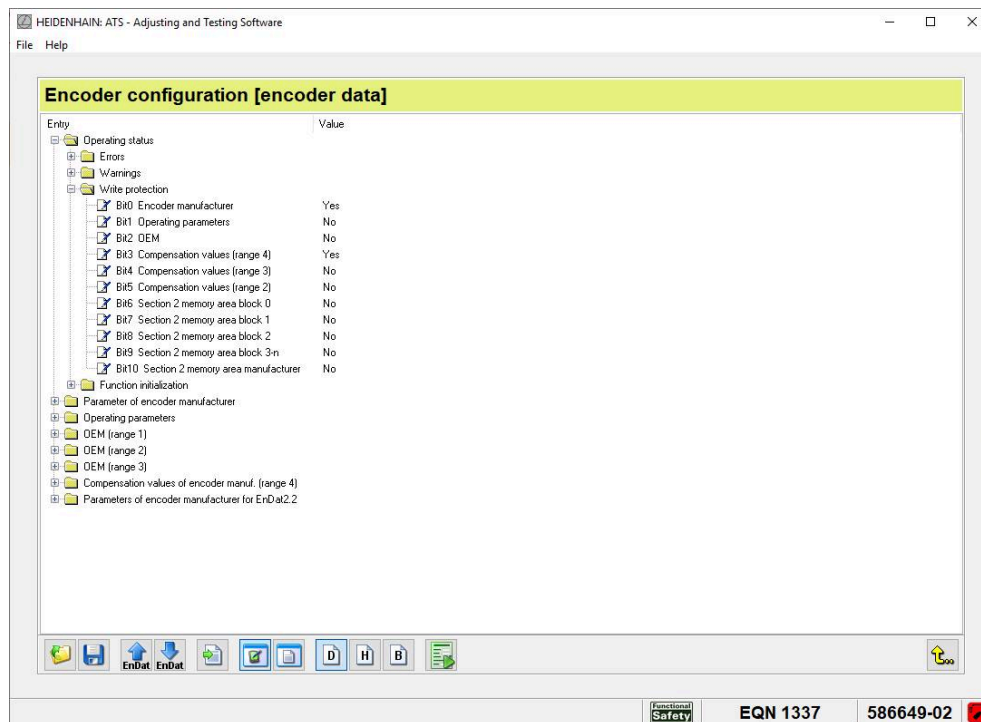

Figure 137: Function view with the folder **Write protection**

Overview of supported valuation numbers

The encoder configuration provides an overview of the valuation numbers the encoder supports.

Path: **Parameters of the encoder manufacturer for EnDat 2.2** ▶ **Diagnostic Status**

Supported valuation numbers are identified by the value "Yes".

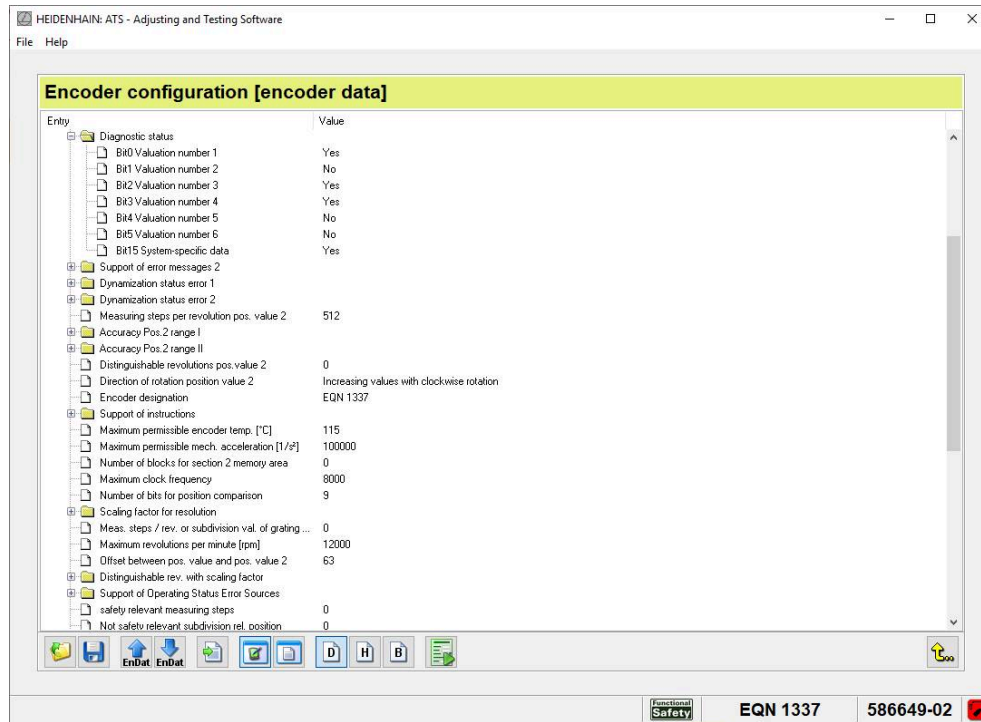

Figure 138: Function view with the folder **Diagnostic status**

11.10 Comparing encoder configurations

11.10.1 Comparison of encoder memory function

You compare two encoder configurations using the Adjusting and Testing Software. The following options are available for comparing two encoder configurations:

- Load the encoder configuration from the encoder and compare it to a file
- Load the encoder configuration from a file and compare it to another file

i If the encoder configurations differ in their EnDat command set (EnDat 2.1 and EnDat 2.2), a comparison is not possible.



- ▶ To call this function, double-click **Comparison of encoder memory contents** in the function menu

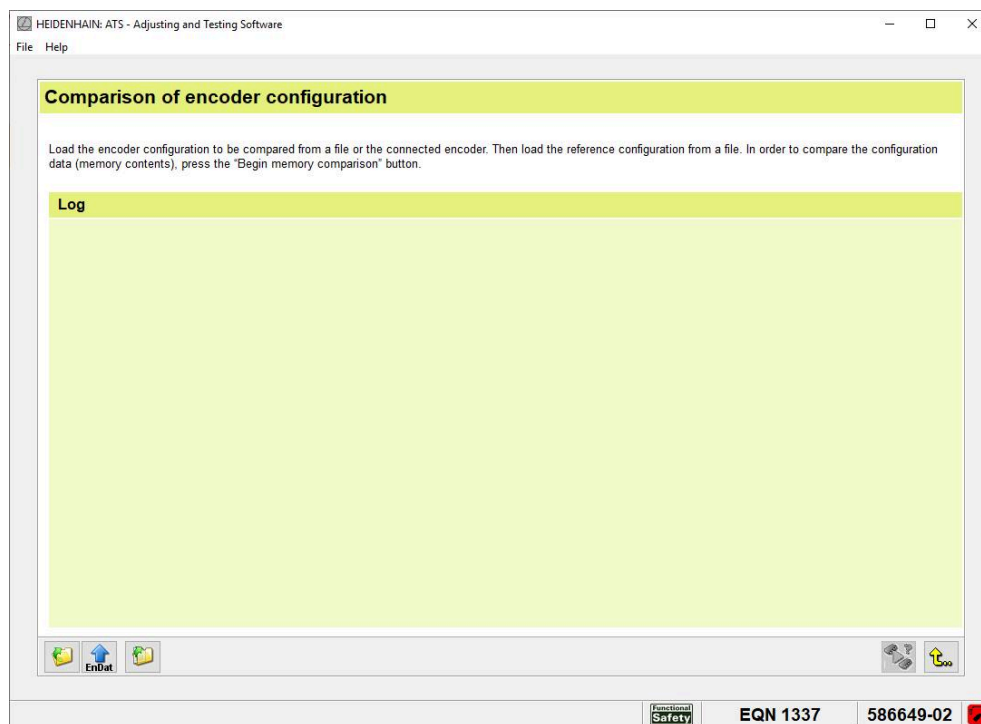





Figure 139: **Comparison of encoder memory contents** function

Operating elements

Icon	Function
	<p>Load file</p> <p>Opens the dialog for selecting the file containing the encoder configuration</p>
	<p>Load encoder memory</p> <p>Starts the export of the encoder memory</p>
	<p>Load comparison file</p> <p>Opens the dialog for selecting the file containing the encoder configuration</p>
	<p>Start comparison</p> <p>Starts the comparison of the loaded encoder configurations</p>

11.10.2 Loading and comparing encoder configurations

For comparison, load two encoder configurations in the Adjusting and Testing Software. You can load the encoder configuration 1 from the encoder or from a file. Then load the encoder configuration 2 from a file and start the comparison.

Loading encoder configuration 1 from encoder



- ▶ Click **Load encoder memory** in the control bar
- > The encoder memory is read out
- > The following message appears in the **Log** section:
Encoder configuration 1 loaded

or

Loading encoder configuration 1 from a file



- ▶ Click **Load file** in the control bar
- ▶ Select the storage location of the file
- ▶ Click **Open**
- > The following message appears in the **Log** section:
Encoder configuration 1 loaded

Loading encoder configuration 2 from a file



- ▶ Click **Load comparison file** in the control bar
- ▶ Select the storage location of the file
- ▶ Click **Open**
- > The following message appears in the **Log** section:
Encoder configuration 2 loaded

Starting the comparison

As soon as the Adjusting and Testing Software has loaded the two encoder configurations, you can start the comparison.



- ▶ Click **Start comparison** in the control bar
- ▶ The differences between the two encoder configurations are listed in a table

The screenshot shows the 'HEIDENHAIN: ATS - Adjusting and Testing Software' window. The main content area is titled 'Comparison of encoder configuration' and contains a table comparing 'Encoder data' and 'config.ecf'. The table has four columns: 'Section', 'Word', 'Config. data 1', and 'Config. data 2'. Below the table are icons for 'D' (Decimal format) and 'H' (Hexadecimal format). At the bottom of the window, there is a status bar with 'Functional Safety', 'EQN 1337', and '586649-02'.

Section	Word	Config. data 1	Config. data 2
Operating parameters	7	58208	16960
Operating parameters	8	22	15
Operating parameters	9	2	0
Operating parameters	10	2	0

Figure 140: Table with differences between the encoder configurations



There may be differences even between encoders with identical encoder ID, e.g. the serial number or signal correction values that are determined individually for every encoder.

Operating elements

Icon	Function
	Decimal format Shows numerical values in decimal format
	Binary format Shows numerical values in binary format
	Load encoder memory Shows the screen for loading encoder configurations

Adjusting the number format

You can choose between different number formats for displaying numerical values.



- ▶ Click **Decimal format** in the control bar to display numerical values in decimal format



- ▶ Click **Hexadecimal format** in the control bar to display numerical values in hexadecimal format

Repeating the comparison

In order to perform another comparison you can return to the selection of the encoder configuration.



- ▶ Click **Load encoder memory** in the control bar
- The Adjusting and Testing Software displays the **Log** section

11.11 Saving the encoder memory

11.11.1 Save encoder memory function

With the function **Save encoder memory** you can read out the memory of the connected encoder and save it as an encrypted ZIP file.

A note can be added to this file.

Only the HEIDENHAIN can read (decode) the ZIP file.

The ZIP file must be e-mailed to the HEIDENHAIN technical helpline for encoders **service.ms-support@heidenhain.de** for evaluation.



This function should not be used in general, but only in coordination with the HEIDENHAIN technical helpline (e.g., sporadic positioning errors that are not due to contamination or signal transmission).



- ▶ To call this function, double-click **Save encoder memory** in the function menu

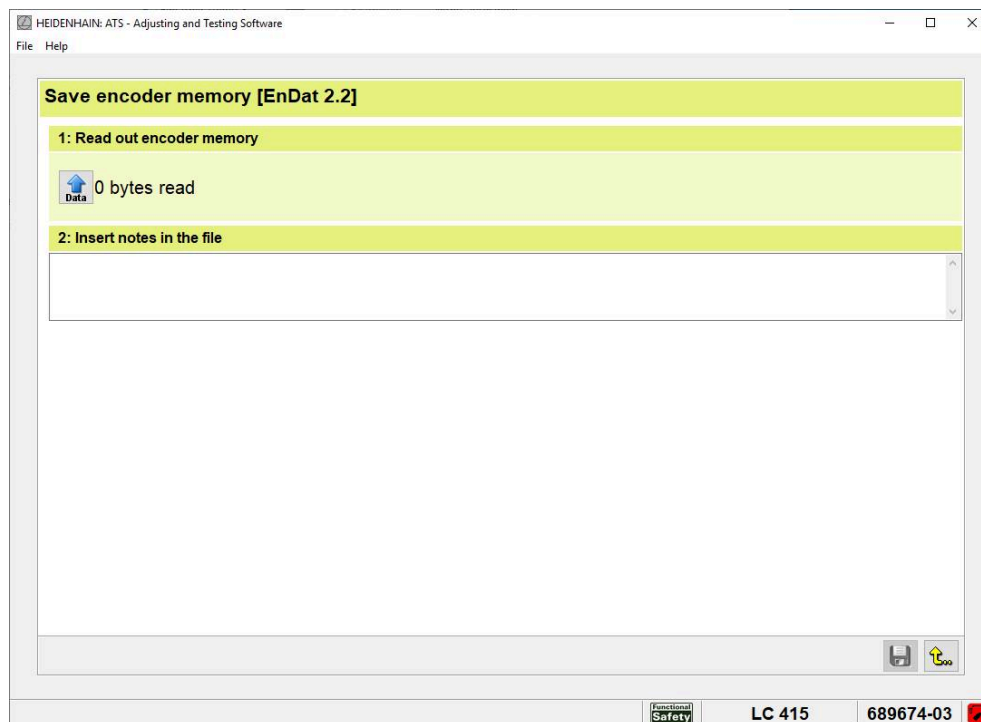



Figure 141: **Save encoder memory** function



- ▶ Click **Save** to save the data to a file

11.11.2 Saving the encoder memory

Symbol	Function
	Read encoder memory Starts the export of the encoder memory
	Save file Opens the dialog for saving the data

11.12 Additional information Position value 2

11.12.1 Function Additional information Position value 2

With safety-related position encoders (functional safety encoders) the Additional information Position value 2 function is used to display the position values 1 and 2. Incremental encoders can also transmit a second position value (depending on the encoder).

Additional information Position value 2 with safety-related position encoders



- To call this function, double-click **Additional information Position value 2** in the function menu

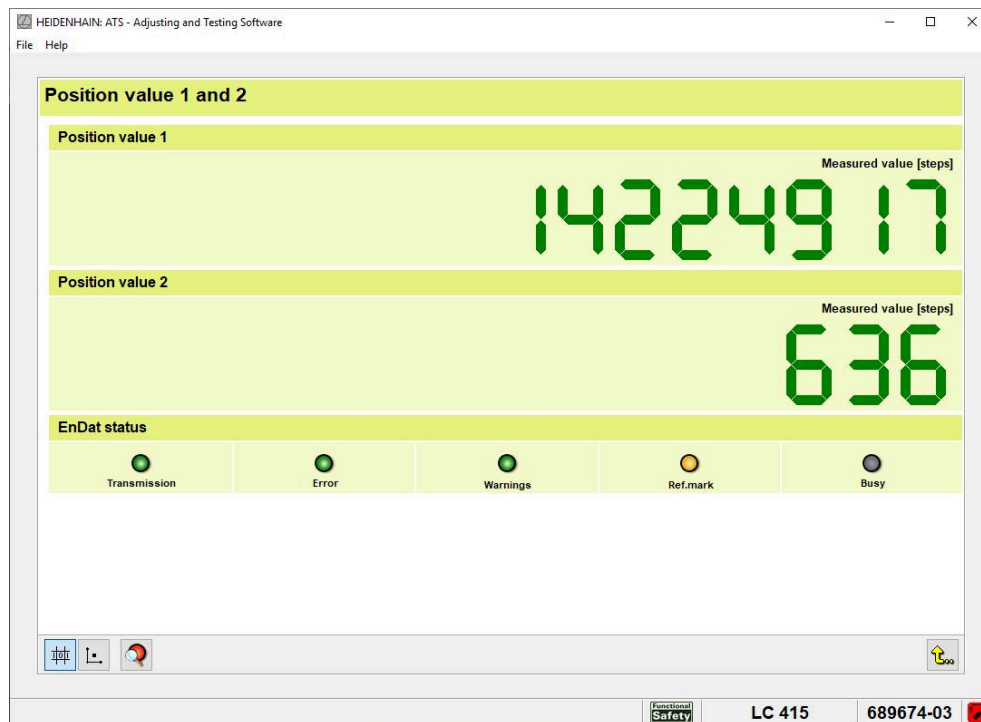

Figure 142: Function Position values 1 and 2 (safety-related position encoder)

Additional information Position value 2 with incremental encoders

- ▶ To call this function, double-click **Additional information Position value 2** in the function menu
- If the reference mark has not yet been detected, both counters display the incremental position
- ▶ Traverse the reference mark
- The **Ref.mark** status switches to yellow
- The Position value 2 counter shows the absolute position

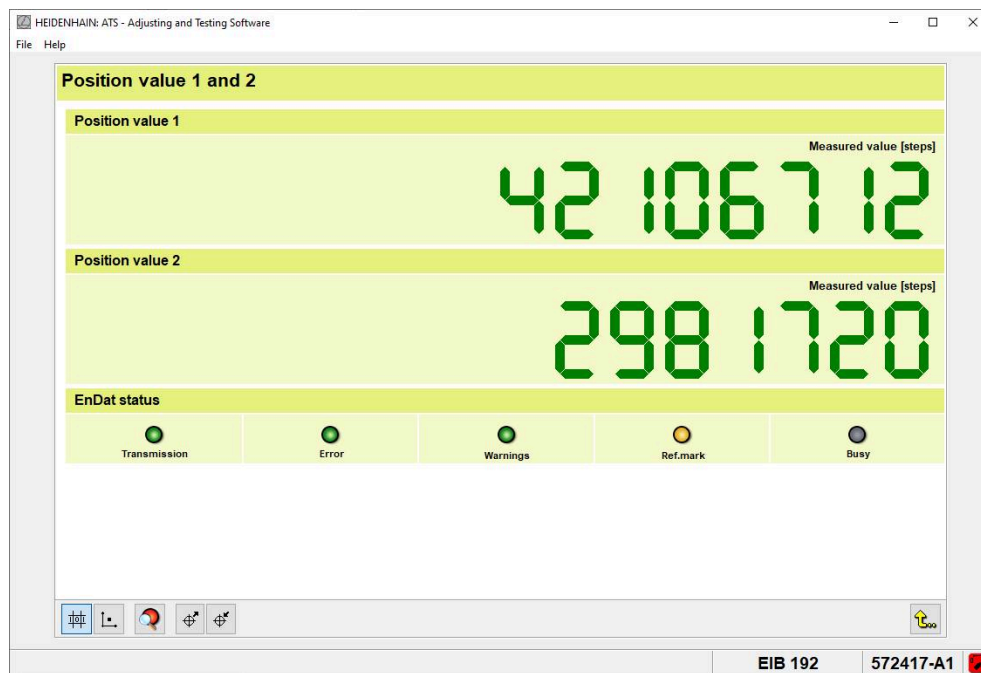







Figure 143: Function Position value 1 and 2 (incremental encoder)

Display	Description
Position value 1	With incremental encoders: incremental position With other encoders: absolute position
Position value 2	With incremental encoders: <ul style="list-style-type: none"> ■ Before referencing: incremental position ■ After referencing: absolute position For encoders that support functional safety: absolute position
Transmission	Status display of data transfer between encoder and testing device <ul style="list-style-type: none"> ■ Green: No status message available ■ Red: Status message available
Fault	Status display of encoder errors <ul style="list-style-type: none"> ■ Green: No status message available ■ Red: Status message available
Warnings	Status display of encoder warnings

Display	Description
	<ul style="list-style-type: none"> ■ Green: No status message available ■ Red: Status message available
Ref.mark	Status display of reference mark detection <ul style="list-style-type: none"> ■ Gray: No reference mark was detected ■ Yellow: Reference mark detected or absolute encoder
Busy	Status display of memory access <ul style="list-style-type: none"> ■ Gray: No access to encoder memory detected ■ Yellow: Access to encoder memory detected

 At this point, access to the encoder memory suggests an encoder error.

11.12.2 Operating elements

Symbol	Function
	Show measured values Displays the measured value in increments
	Show position values Converts the measured value into a position value Unit: micrometers or degrees (depending on the encoder)
	Show status information Displays a list of errors and warnings
	Set datum shift Opens the dialog for setting the datum shift Further information: "Setting datum shift", Page 205
	Canceling datum shift Opens the dialog for deleting the datum shift Further information: "Resetting a datum shift", Page 209

11.13 Display of additional sensors

Some encoders feature multiple sensors, e.g. temperature sensors of a direct drive. You can view the measured values of the sensors in the **Additional sensors** function.



- ▶ Double-click **Additional sensors** in the function menu
- > The Adjusting and Testing Software displays the measured values of the sensors

Operating elements

Icon	Function
	Display of measured value in Fahrenheit Switches the measured value display from Celsius to Fahrenheit

11.14 Measuring temperature

Some encoders feature temperature sensors. You can view the current temperature values in the **Temperature display** function. Depending on the encoder, internal and external temperature sensors are displayed (e.g., temperature switches or temperature-dependent resistors in the drive).



- ▶ Double-click **Temperature display** in the function menu to call the function
- The Adjusting and Testing Software displays the current temperatures

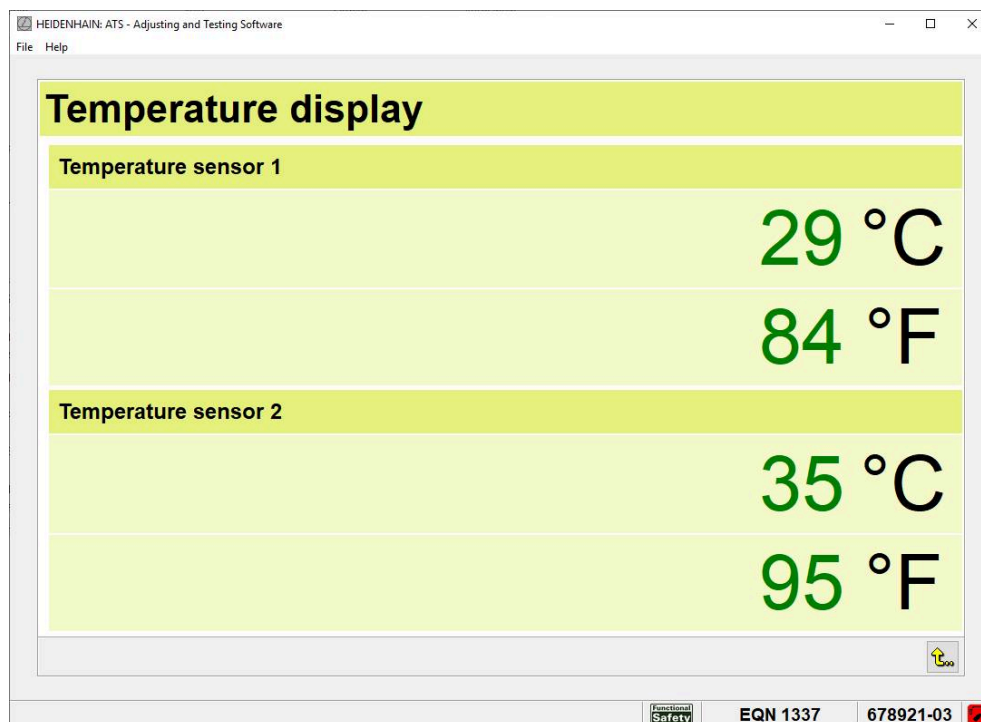

Figure 144: **Temperature display** function



Extremely high temperature values indicate that the temperature sensor is not connected, a contact is open or a cable has broken. Extremely low temperature values may suggest a short circuit.

Conversion of the temperature value for the PT 1000 temperature sensor

The internal temperature evaluation of HEIDENHAIN encoders typically refers to the **KTY 84-130** temperature sensor. For measurement with the **PT 1000** temperature sensor, the temperature value must be converted.

The conversion can be performed by the encoder, by the Adjusting and Testing Software or by the subsequent electronics (depending on the encoder). For this purpose the corresponding parameters must be configured in the encoder configuration.



A detailed description of the temperature value conversion can be found in the "**Encoders for Servo Drives**" brochure, chapter "Connectable temperature sensors".

- ▶ www.heidenhain.com/documentation
- ▶ Enter the document ID **208922**

Supported temperature sensor types (word 50)

Temperature value conversion within the encoder is only possible if the encoder supports the evaluation of the **PT 1000** temperature sensor. To see which temperature sensor types the encoder supports, refer to the encoder configuration.

Path: **Parameters of the encoder manufacturer for EnDat 2.2** ► **Support temperature sensor type** (word 50)

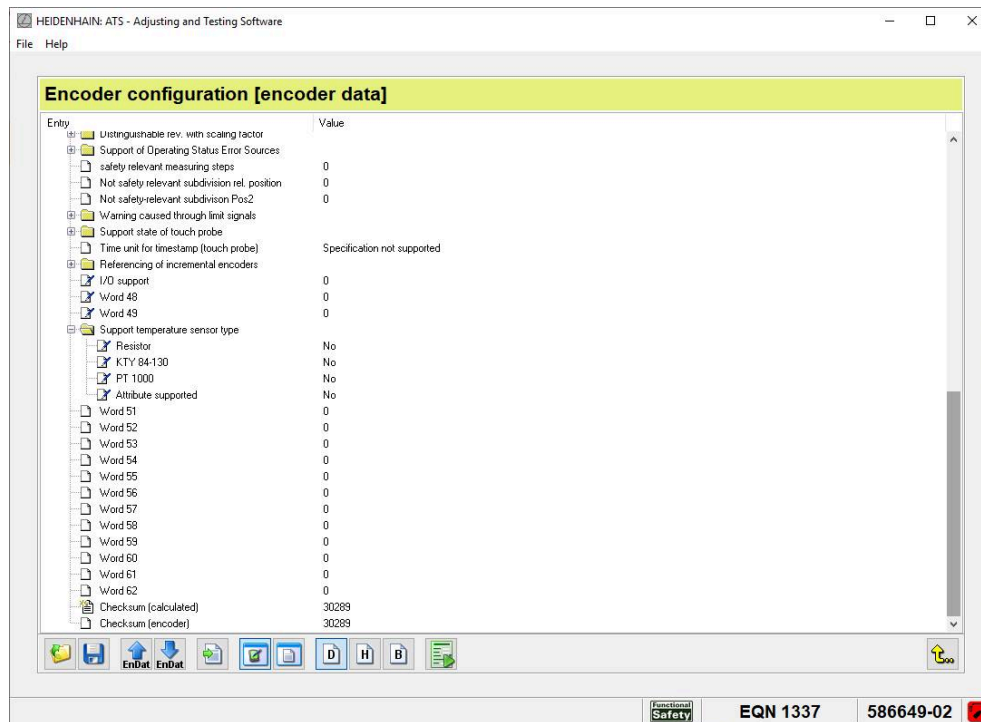

Figure 145: **Support temperature sensor type** parameter in the encoder configuration

Supported temperature sensor types are identified by the value "Yes".

Conversion of the temperature value by the encoder (word 9)

Precondition: The encoder supports the evaluation of the **PT 1000** temperature sensor.

If the value **PT 1000** is defined in the **Temperature sensor type** parameter, the conversion is performed by the encoder. The Adjusting and Testing Software displays the temperature value converted by the encoder.

Path: **Operating parameters** ► **Temperature sensor type** (word 9)

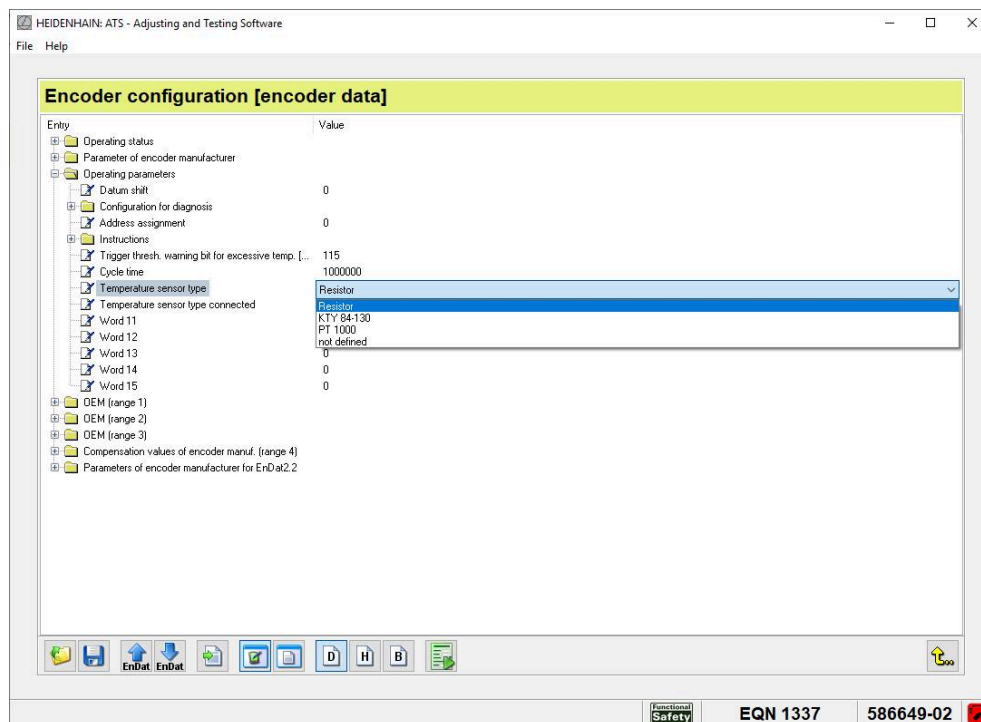

Figure 146: **Temperature sensor type** parameter in the encoder configuration

Conversion of the temperature value by the Adjusting and Testing Software (word 10)

If the encoder does not support the evaluation of the **PT 1000** temperature sensor, the conversion can be performed by the Adjusting and Testing Software. The conversion is active if the value **PT 1000** is defined for the **Temperature sensor type connected** parameter (word 10) in the encoder configuration. The setting has no effect on the internal temperature evaluation of the encoder, but can be used for display by the subsequent electronics.

Path: **Operating parameters** ▶ **Temperature sensor type connected** (word 10)

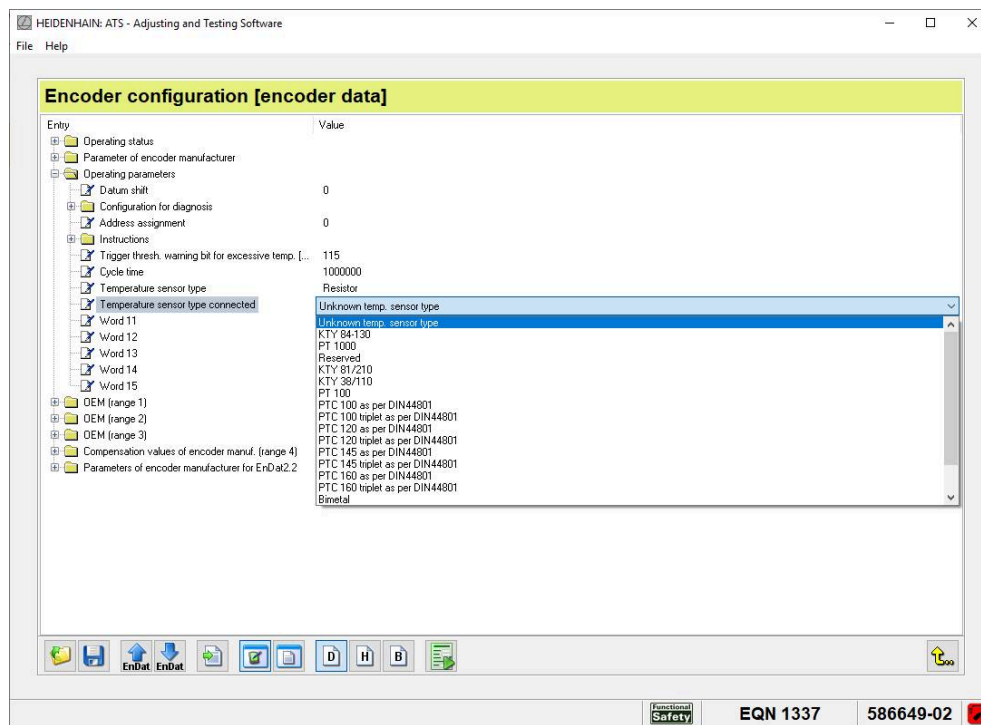



Figure 147: **Temperature sensor type connected** parameter in the encoder configuration

12

**Inspecting encoders
with serial interface
of the EnDat 3 type**

12.1 Overview

The Adjusting and Testing Software features the following functions for inspecting encoders with EnDat 3 interface:

Symbol	Function	Description
	EnDat 3	Tests for encoders with interfaces of the EnDat 3 type
	Voltage display	Measured values of voltage and current supply

i The displays and the scope of functions of the Adjusting and Testing Software depend on the connected encoder and on the software configuration. When you establish the connection to the encoder, the function menu shows the available functions and operating elements.

12.2 Performing EnDat 3 tests

EnDat 3 function

The **EnDat 3** function consists of the following screens, which can be displayed by clicking the tabs:

- **Position display:** Current encoder position
- **Online diagnostics:** Determine the function reserves of the encoder based on valuation numbers
- **Encoder status:** Display of current status information
- **Sensors:** Display of sensor measured values
- **ID label (EL):** Excerpt from the encoder memory
- **Configuration:** Adjust the encoder configuration in the encoder memory
- **Wizards:** Run wizard-assisted tests, e.g. Functional-safety encoder check
- **Operating status data:** Display the operating status data from the encoder memory; reset extreme values
- **Miscellaneous functions:** Display of the available additional functions



▶ Double-click **EnDat 3** in the function menu to call this function

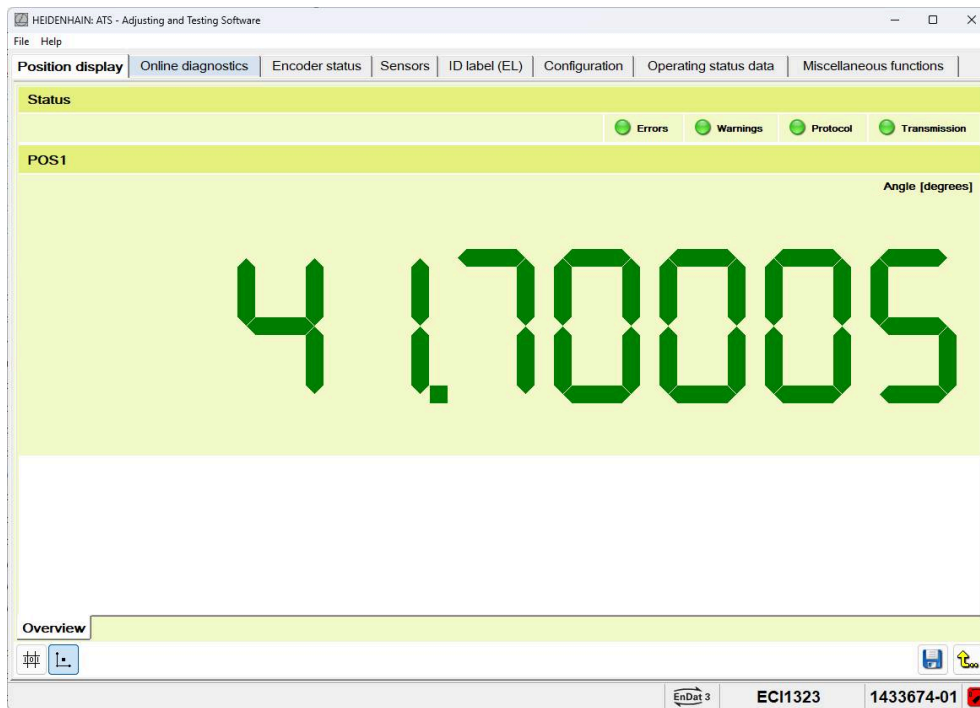

Figure 148: **EnDat 3** function

12.2.1 Position display view

The **Position display** view shows the current encoder position and the status of the connected encoder.

- ▶ Click the **Position display** tab to call this view

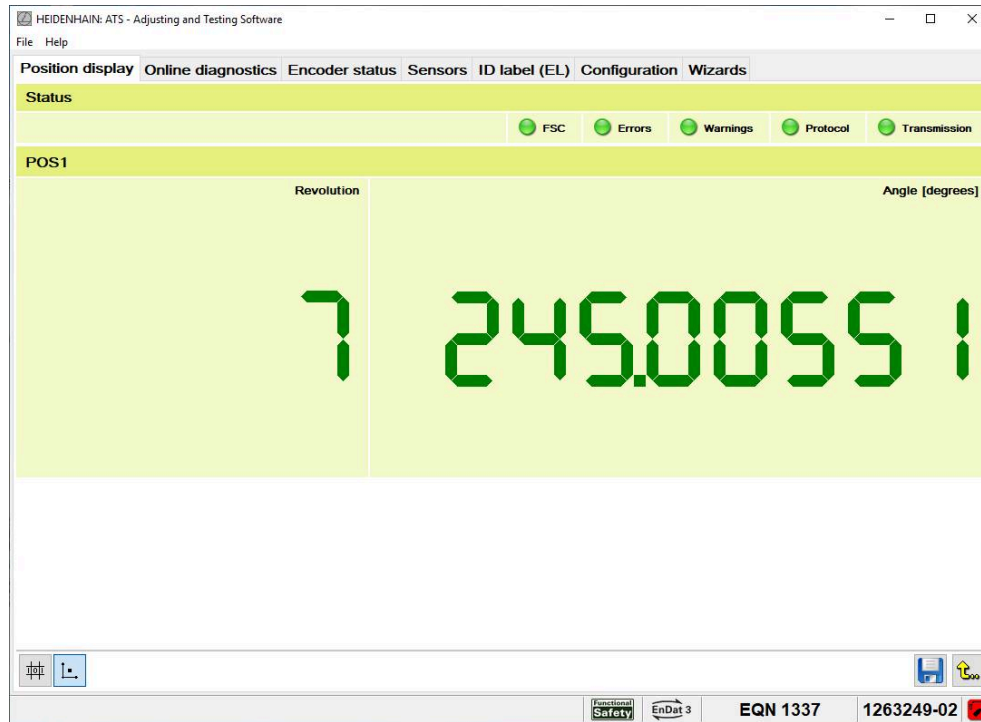

Figure 149: **Position display** view

Status section

Display	Description
Reference mark	Status display of reference mark detection <ul style="list-style-type: none"> ■ Gray: No reference mark was detected ■ Blue: A reference mark was detected
FSC	Status display of the safety-relevant functions <ul style="list-style-type: none"> ■ Green: Tests completed without errors ■ Red: At least one test returned an error ■ Blue: FDS test is running The Adjusting and Testing Software performs the following tests for each position request: <ul style="list-style-type: none"> ■ CSS test ■ SOL test ■ SF status ■ AA test ■ Data test ■ WD test The FDS test (forced dynamic sampling; cyclic testing of the monitoring function in the encoder) takes place approx. every 200 seconds and when changing to a different view.
Errors	Status display of encoder errors (evaluation of error messages and error codes according to EnDat 3 interface specification) <ul style="list-style-type: none"> ■ Green: No status message available ■ Red: Status message available
Warnings	Status display of encoder warnings (evaluation of warning according to EnDat 3 interface specification) <ul style="list-style-type: none"> ■ Green: No status message available ■ Red: Status message available
Protocol (log)	Status display of the validity of the transmitted data (log and possibly other information) <ul style="list-style-type: none"> ■ Green: No status message available ■ Red: Status marked; information identified as invalid by the encoder
Transmission	Status display of data transfer between encoder and testing device <ul style="list-style-type: none"> ■ Green: No status message available ■ Red: Status message available



The FSC status display does not comprise all safety-relevant functions. Perform a functional-safety encoder check to test all safety-relevant functions of the encoder.

Further information: "Checking the functional safety of the encoder", Page 317



For more information on EnDat and functional safety, visit: www.endat.de



If the status displays indicate errors, you can view the corresponding status messages in the **Encoder status** screen.

Further information: "Encoder status view", Page 294

POS1 section

Display	Description
POS1	<p>Absolute encoder position (position value 1)</p> <p>Unit: micrometers, degrees, or nano-epsilons (depending on the encoder)</p> <p>For multiturn rotary encoders, the Adjusting and Testing Software in addition displays the number of revolutions.</p>

Operating elements

Symbol	Function
	<p>Show measured values</p> <p>Displays the measured value in increments</p>
	<p>Show position values</p> <p>Converts the measured value into a position value</p> <p>Unit: micrometers, degrees, or nano-epsilons (depending on the encoder)</p>
	<p>Save file</p> <p>Opens the dialog for saving the log to a PDF file</p> <p>Further information: "Saving log data", Page 333</p>

Switching between measured values view and position view

You can switch the counter display between measured values view and position view.

Measured values view

The **Measured values view** shows the count value in increments.

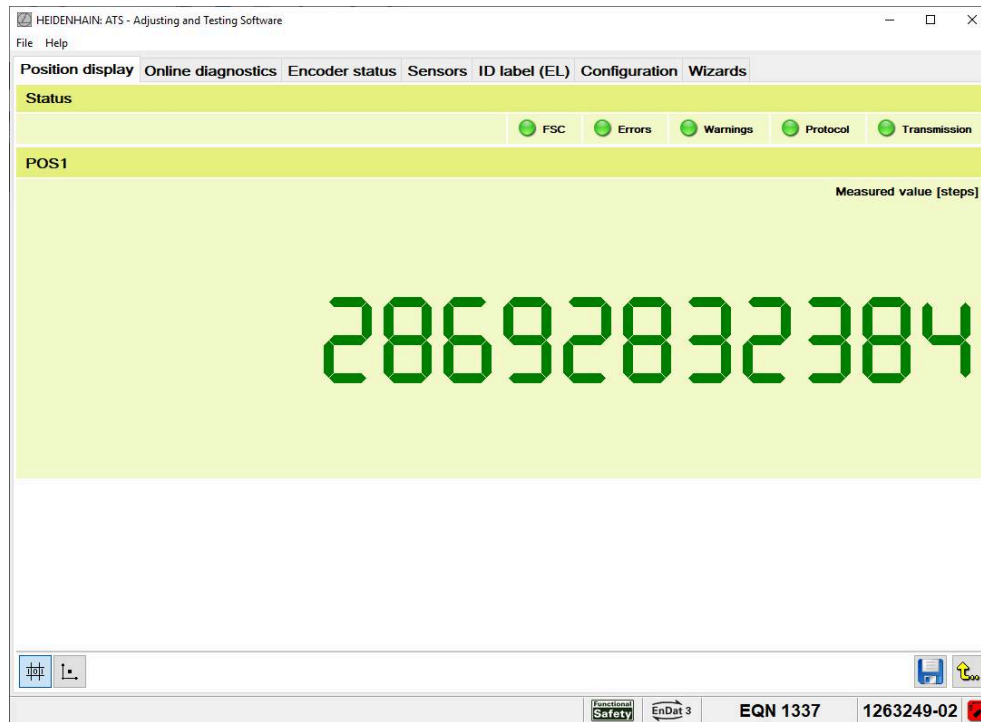

Figure 150: **Measured values view** of the **Position display** function

Position view

In the **Position view**, the Adjusting and Testing Software converts the count value into a position value. The position value is displayed in micrometers or degrees (depending on the encoder).

For multiturn rotary encoders, the Adjusting and Testing Software in addition displays the number of revolutions.

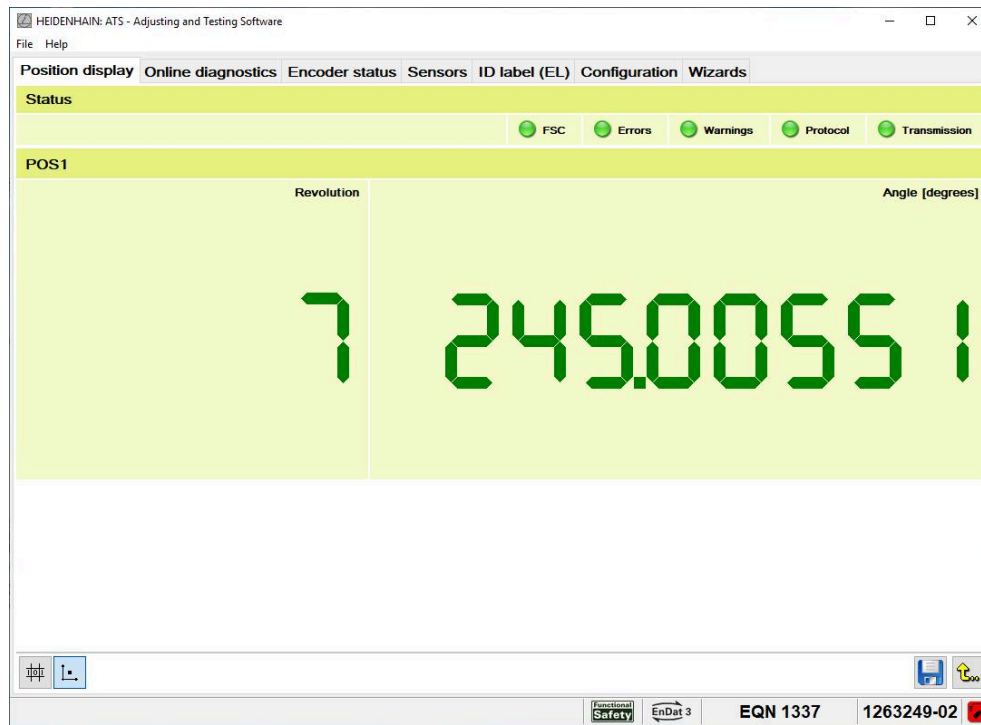

Figure 151: **Position view** of the **Position display** function

Switching between the views



- ▶ Click **Show measured values** in the control bar to switch to the measured values view



- ▶ Click **Show position values** in the control bar to switch to the position view

Position display view for multidimensional positions

The Adjusting and Testing Software supports the display of multidimensional positions.

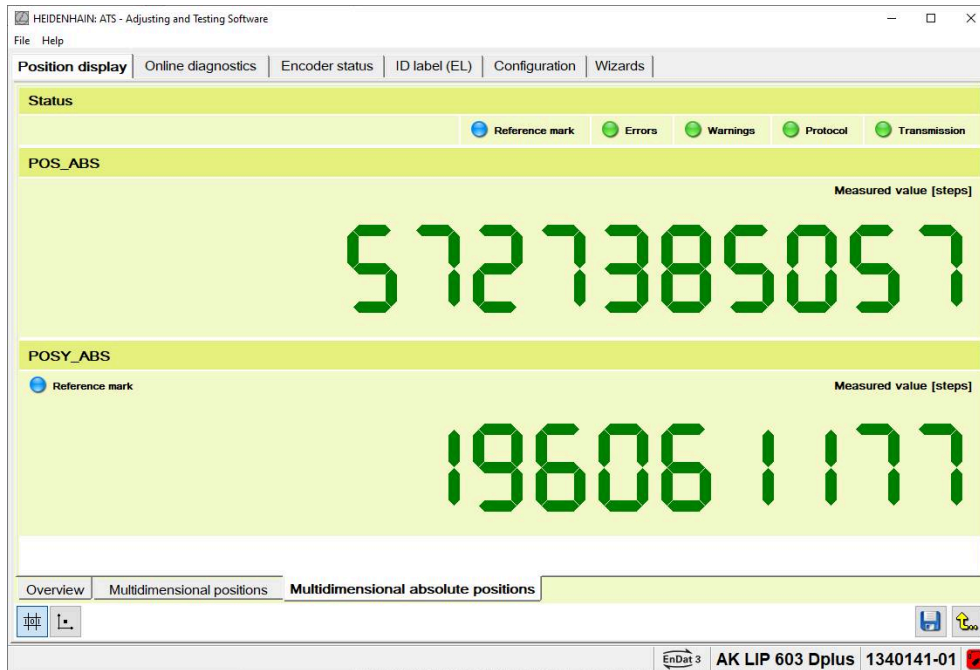

Figure 152: Position display view with multiple positions

i With incremental encoders, successful reference mark recognition is required for the absolute values to be displayed. Otherwise, all counters show the incremental position values. Each axis has its own **Reference mark** status display.

- ▶ Reference all axes to examine an encoder with multidimensional positions
- > The **Reference mark** status displays switch to blue
- > The counters for the absolute positions show the absolute values

▶ Click the desired tab in the lower navigation bar to switch between the views
 The positions that are displayed depend on the connected encoder. The encoder in the example transmits the following positions:

Display	Description
POS1	Incremental position of the principal axis (main direction of measurement)
POS_ABS	Current position of the principal axis
POSY	Incremental position of the Y axis
POSY_ABS	Absolute position of the Y axis

i POS1 is transmitted in the main frame via the HPF with each query. The other positions are transmitted via the LPF as additional information.

12.2.2 Online diagnostics screen

You can monitor the encoder status with the **Online diagnostics** screen.

The Adjusting and Testing Software records valuation numbers, which are transmitted together with the position value when the encoder is traversed. On the basis of these valuation numbers, the Adjusting and Testing Software determines the current function reserves of the encoder.

► Click the **Online diagnostics** tab to call this view

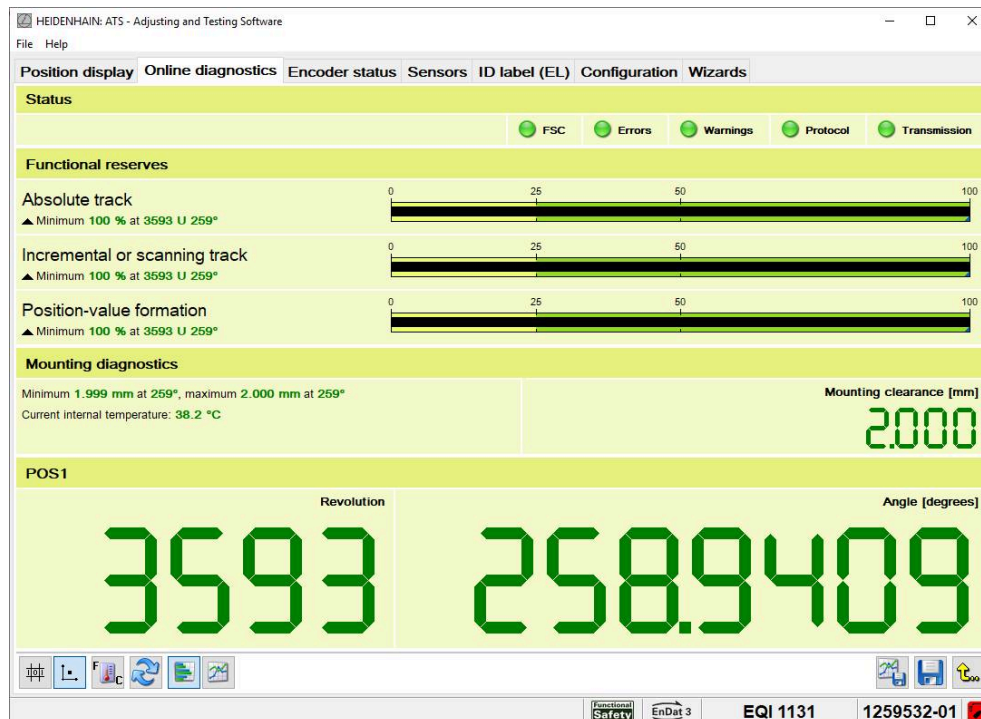

Figure 153: **Online diagnostics** screen

Display	Description
Status	<p>i The status displays correspond to those of the Position display view.</p> <p>Further information: "Status displays of the position display", Page 281</p>
Functional reserves	<p>The following valuation numbers are transferred and displayed, depending on the connected encoder:</p> <ul style="list-style-type: none"> ■ Valuation number 3: Evaluation of the absolute track or evaluation of the reference pulse width or sum ■ Valuation number 1: Evaluation of the incremental track or scanning track ■ Valuation number 4: Evaluation of the position value formation

Display	Description
Mounting parameters	<p>Display of the mounting clearance (e.g., for rotary encoders without integral bearing)</p> <ul style="list-style-type: none"> ■ Mounting clearance: Distance at the current position ■ Minimum: Smallest distance in the traversed area ■ Maximum: Greatest distance in the traversed area ■ Current internal temperature: Measured value from the sensor in the encoder
POS1	<p>Absolute encoder position (position value 1) Unit: micrometers or degrees (depending on the encoder)</p> <p>For multiturn rotary encoders, the Adjusting and Testing Software in addition displays the number of revolutions</p>

i The **evaluation of the reference pulse sum** (valuation number 3) refers to the function reserve during the acquisition and evaluation of the reference pulse by the signal converter or the encoder. Thus, it does not evaluate the reference pulse itself (e.g., its position and width), but its entire evaluation function including the characteristic properties of the reference pulse and the signal converter or encoder. With the components "Incremental signal" and "Evaluation of the reference pulse sum", the online diagnostics thus allows for diagnosing during operation and supports regular functional checks.

The **Online diagnostics** view comprises:

- Bar graph
- X/Y display

Bar graph

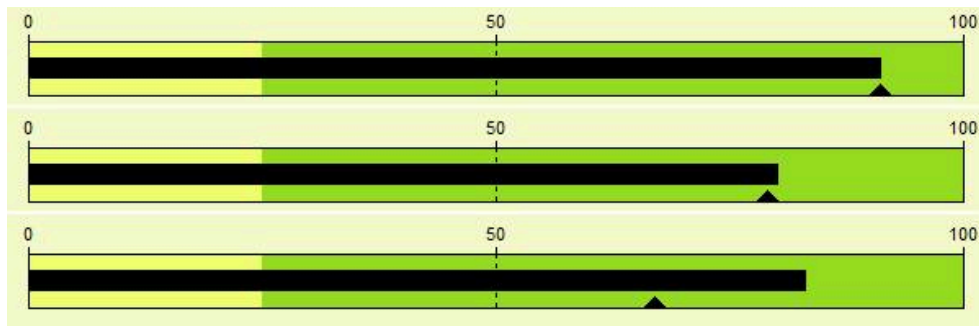

Figure 154: Bar graph of the **Online diagnostics** function

The bar display of the Adjusting and Testing Software shows each valuation number in a bar graph. The scale of the bar corresponds to the maximum function reserve of the encoder. The minimum, i.e. the smallest value within the traversed range, is determined for each valuation number. The drag indicator marks the minimum. The black bar shows the value transferred last.

The tolerance ranges are indicated by color in each bar graph:

Display	Function reserve	Description
Yellow	0 to 25%	<ul style="list-style-type: none"> ■ Minimum is outside the specification ■ Encoder maintenance recommended
Green	26 to 100%	<ul style="list-style-type: none"> ■ Minimum is within the specification ■ Encoder function reserves are sufficient

X/Y display

The X/Y display may be additionally available, depending on the encoder. It shows the course of the function reserves over the entire traverse path.

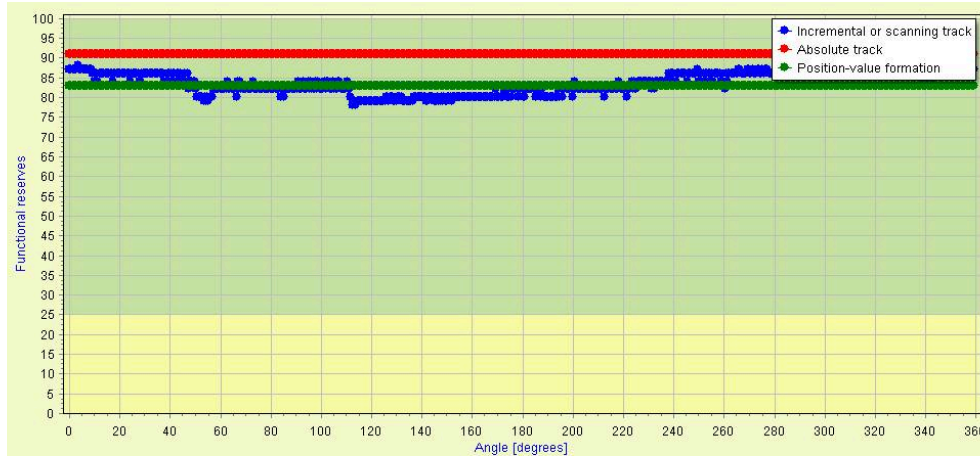









Figure 155: X/Y display of the **Online diagnostics** function

Depiction	Description
X axis	Position Input: millimeters or degrees (depending on the encoder)
Y axis	Function reserve

Operating elements

Symbol	Function
	<p>Show measured values</p> <p>Displays the measured value in increments</p>
	<p>Show position values</p> <p>Converts the measured value into a position value Unit: micrometers or degrees (depending on the encoder)</p>
	<p>Display of measured value in degrees Celsius or Fahrenheit</p> <p>Switches the measured value display from Celsius to Fahrenheit or vice versa</p>
	<p>Delete values</p> <p>Deletes the recorded values and resets the drag indicators to 100%</p>
	<p>Switch to bar display</p> <p>Shows the bar graphs</p>
	<p>Switch to X/Y display</p> <p>Shows the X/Y display</p>
	<p>Export data</p> <p>Opens the dialog for exporting records to a TXT file</p>
	<p>Save file</p> <p>Opens the dialog for saving the log to a PDF file Further information: "Saving log data", Page 333</p>

Performing online diagnostics

Running the measurement in the bar display



- ▶ If necessary, click **Switch to bar display** in the control bar
- The Adjusting and Testing Software displays the **minimum** value and the starting position of the measurement for each valuation number
- ▶ Traverse the entire measuring range
- The valuation numbers are recorded
- If one of the minimum values is not reached, the Adjusting and Testing Software updates the display

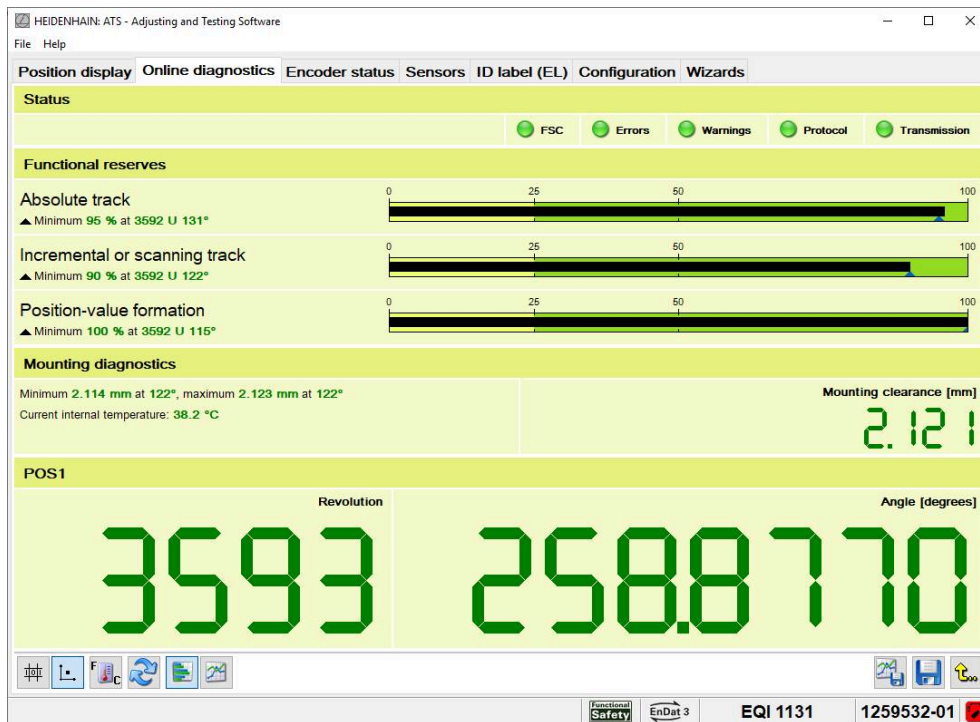

Figure 156: Result of the online diagnostics in the bar display

i You can switch the counter display between measured values view and position view.
Further information: "Switching between measured values view and position view", Page 283

Running the measurement in the X/Y display



- ▶ If necessary, click **Switch to X/Y display** in the control bar
- ▶ Traverse the entire measuring range
- ▶ The valuation numbers are recorded
- ▶ The diagram shows the function reserve at the respective position

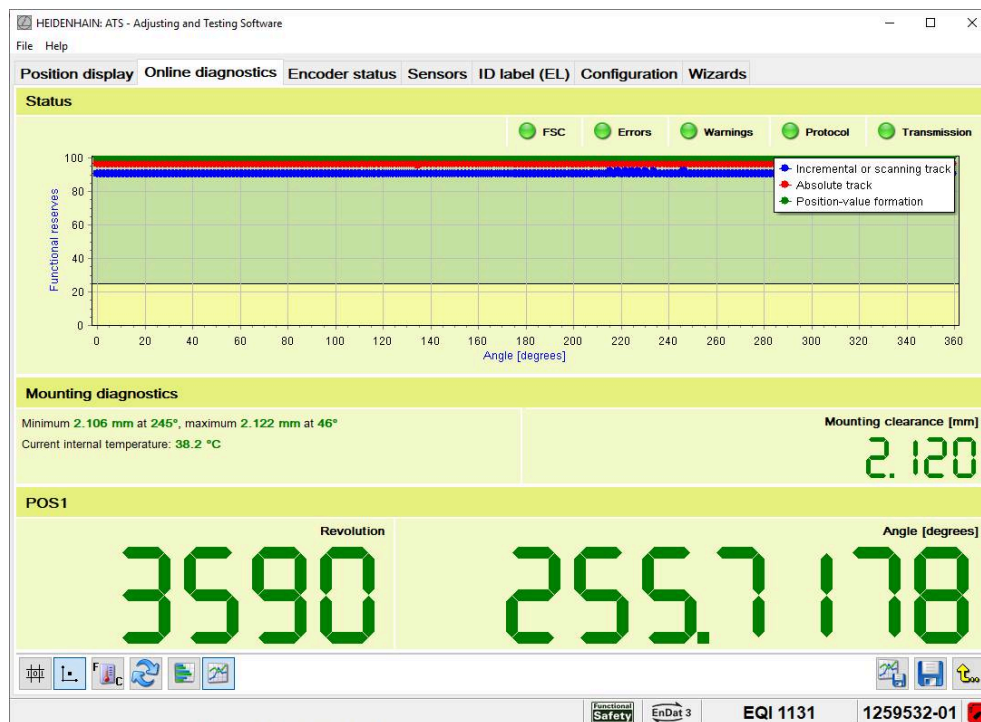

Figure 157: Result of the online diagnostics in the X/Y display



You can switch the counter display between measured values view and position view.

Further information: "Switching between measured values view and position view", Page 283



If you position the mouse pointer on a point in the diagram, a mouseover text appears with brief information (e.g., the number of revolutions of a multiturn encoder).



You can save and print the active diagram.

Further information: "Adjusting, exporting and printing diagrams", Page 48



To examine a section more closely, you can zoom in on the diagram view.

Further information: "Magnifying the diagram view", Page 48

Switching the unit



- ▶ Click **Show measured value in degrees Celsius or Fahrenheit** in the control bar to switch temperature displays between Celsius and Fahrenheit

Exporting data

You can save the recorded data to a TXT file.



- ▶ Click **Export data** in the control bar
- ▶ Select the desired storage location in the dialog
- ▶ Enter the file name
- ▶ Click **Save**
- > The file is saved

Deleting values

You can delete the recorded values to perform a new measurement.



- ▶ Click **Delete values** in the control bar
- > The **Minimum** value of each valuation number is deleted



The bar display is reset as soon as you start a new measurement.

12.2.3 Encoder status view

The **Encoder status** view shows the errors and warnings transmitted by the encoder and the status messages on transmission.

- ▶ Click the **Encoder status** tab to call this view

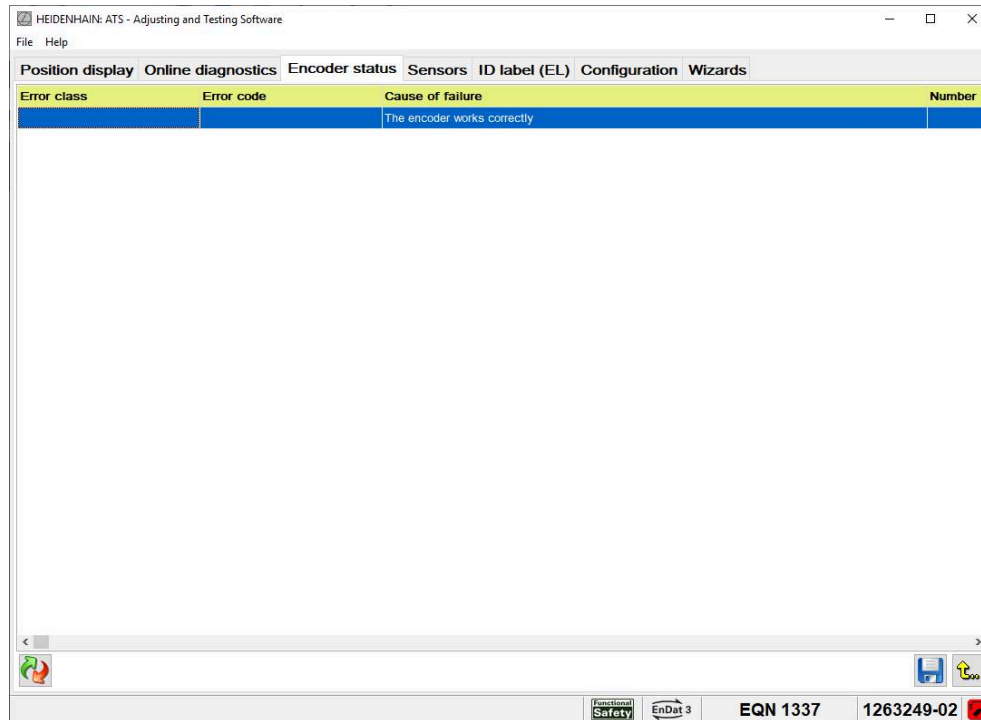





Figure 158: **Encoder status** view

Operating elements

Symbol	Function
	<p>Clear status messages</p> <p>Clears the displayed status messages and resets reference mark detection for incremental encoders</p>
	<p>Save file</p> <p>Opens the dialog for saving the log to a PDF file</p> <p>Further information: "Saving log data", Page 333</p>

Resetting status messages

You should delete any existing status messages before each check.

- 
 - ▶ Click **Delete status messages**
 - > The status messages are deleted
 - > For incremental encoders, the reference mark detection is reset



If there are still status messages in the **Encoder status** view, this indicates that the corresponding errors are still present.

12.2.4 Sensor technology view

The **Sensors** tab comprises:

- **Sensors**
- **Vibration analysis**
- ▶ Click the desired tab in the lower navigation bar to switch between the views

Sensors

In the **Sensors** view you can see the current measured values of the connected sensors. Depending on the encoder, internal and external temperature sensors are supported, such as temperature switches or temperature-dependent resistors in the drive.

- ▶ Click the **Sensors** tab to call this view

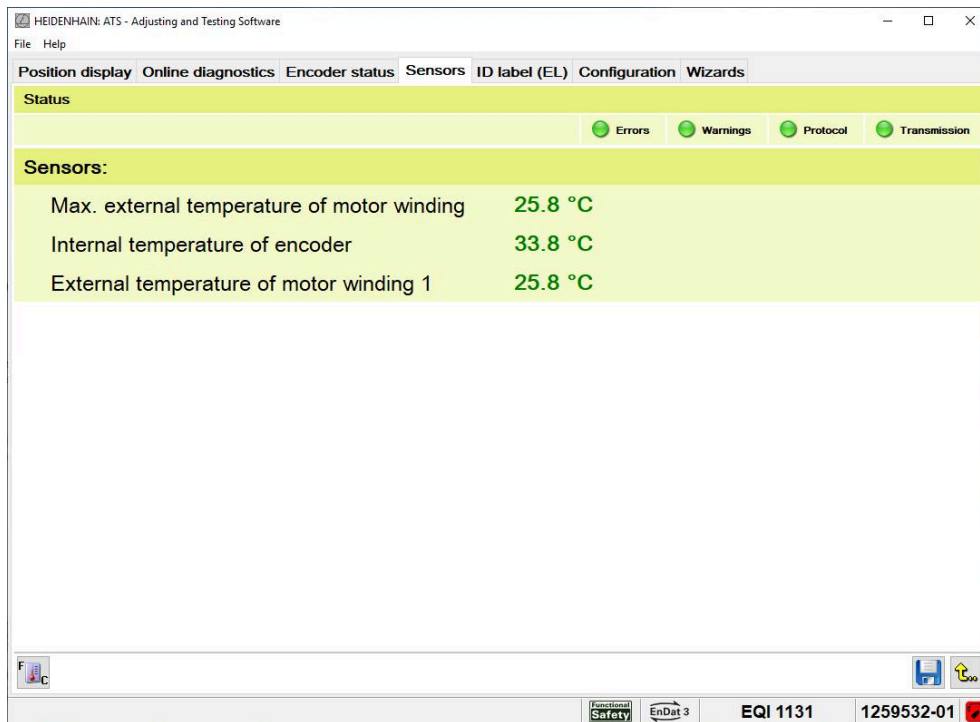

Figure 159: **Sensors** view

i Extremely high temperature values indicate that the temperature sensor is not connected, a contact is open or a cable has broken. Extremely low temperature values may suggest a short circuit.

Operating elements

Symbol	Function
	Display of measured value in degrees Celsius or Fahrenheit Switches the measured value display from Celsius to Fahrenheit or vice versa
	Save file Opens the dialog for saving the log to a PDF file Further information: "Saving log data", Page 333

Switching the unit



- ▶ Click **Show measured value in degrees Celsius or Fahrenheit** in the control bar to switch temperature displays between Celsius and Fahrenheit

12.2.5 ID label (EL) view

Encoders with EnDat interface feature an internal encoder memory. You can access the encoder memory via the Adjusting and Testing Software. The **ID label (EL)** view shows an excerpt from the configuration of the connected encoder.

- ▶ Click the **ID label (EL)** tab to call this view

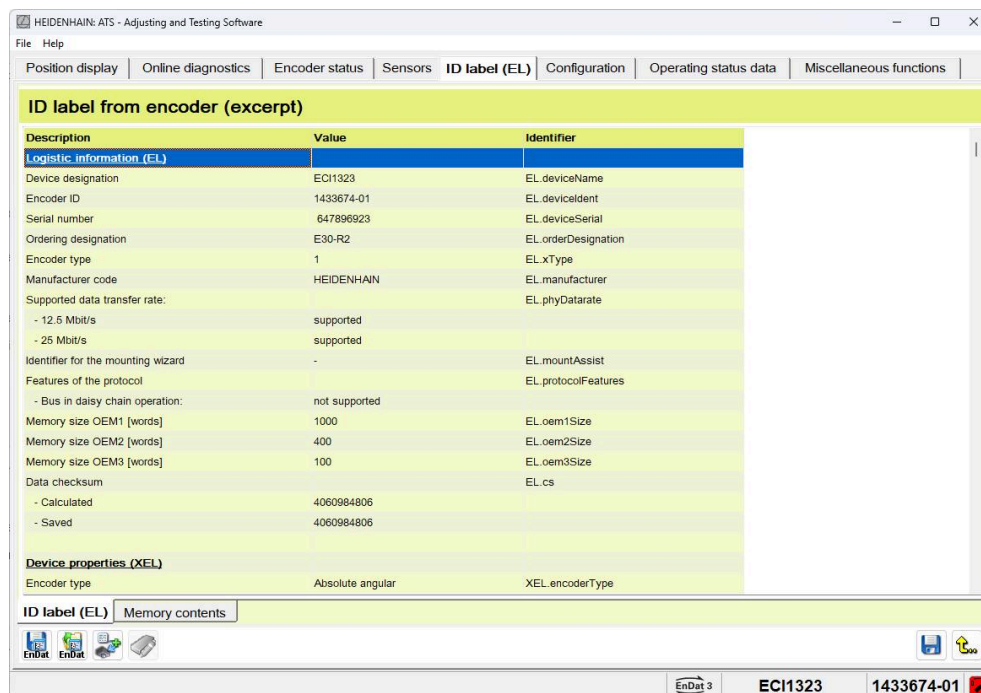

Figure 160: ID label (EL) view

The **ID label (EL)** tab comprises the following views:

- **ID label (EL)**
- **Memory contents**
- ▶ Click the desired tab in the lower navigation bar to switch between the views.

ID label (EL)

In the **ID label (EL)** view you can do the following:

- Save the entire encoder configuration to a file
- Load the encoder configuration from a file to the **ID label (EL)** screen







Values displayed in green can be edited in the **Configuration** screen.
Further information: "Configuration view", Page 299



Values displayed in orange indicate faulty structure checksums.
Further information: "Correcting structure checksums", Page 297

Operating elements

Symbol	Function
	<p>Save the encoder configuration to a file</p> <p>Opens the dialog for saving the encoder configuration to a JSON file</p>
	<p>Load the encoder configuration from a file</p> <p>Opens the dialog for selecting the JSON file containing the encoder configuration</p>
	<p>Correct the SET and XSET structure checksums</p> <p>Corrects the SET and XSET structure checksums</p>
	<p>Save file</p> <p>Opens the dialog for saving the log to a PDF file</p> <p>Further information: "Saving log data", Page 333</p>
	<p>Write OEM areas to encoder</p> <p>Opens the dialog for selecting the JSON file containing the OEM areas to be written to the encoder</p>

Saving the encoder configuration to a file

You can save the encoder configuration as a JSON file on the computer for diagnostic purposes.



- ▶ Click **Save encoder configuration to a file** in the control bar
- ▶ Select the desired storage location in the dialog
- ▶ Enter the file name
- ▶ Click **Save**
- > The complete encoder configuration is saved to the file.

Loading the encoder configuration from a file

You can load the encoder configuration from a JSON file to the **ID label (EL)** screen.



- ▶ Click **Load encoder configuration from file** in the control bar
- ▶ Select the storage location in the dialog
- ▶ Click **Open**
- > The encoder configuration is loaded from the file.
- > The **ID label (EL)** view shows an excerpt from the loaded encoder configuration.
- > The file name is shown in the title bar.
- ▶ To return to the configuration of the connected encoder, the **ID label (EL)** view must be reloaded:
 - Click any desired tab
 - Click the **ID label (EL)** tab once again

Correcting structure checksums



- ▶ Click **Correct SET and XSET structure checksums** in the control bar
- > The structure checksums are corrected.

Memory contents

You can load the encoder configuration from the encoder and save it as a ZIP file on the computer for backup or diagnostic purposes.



The ZIP file is protected by a password and can only be decoded by the den HEIDENHAIN Service.

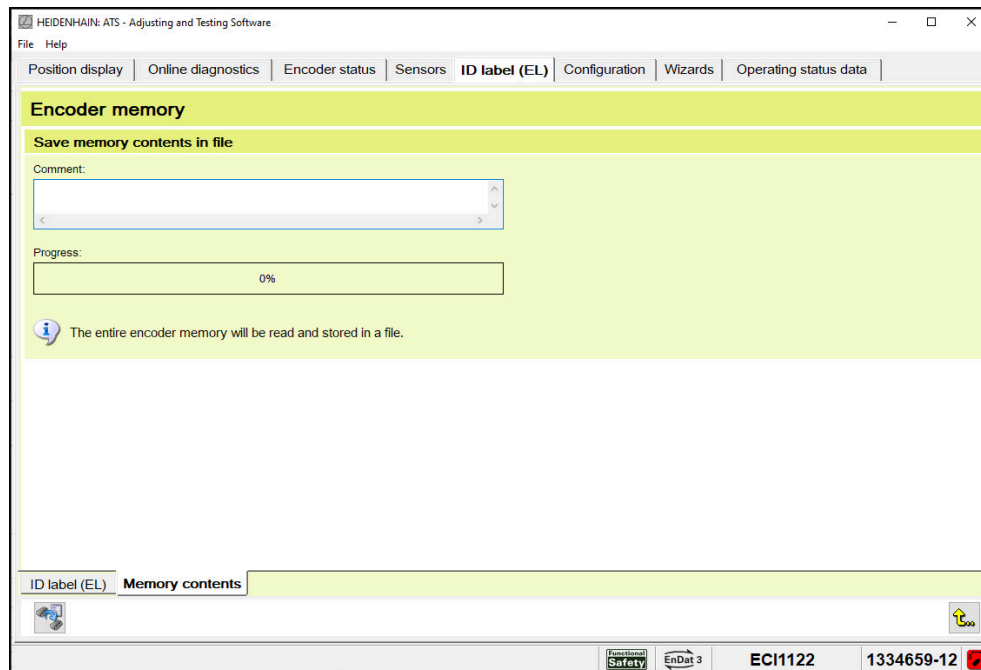

Figure 161: **Memory contents** view



- ▶ Click **Save memory contents to a file** in the control bar
- ▶ Select the desired storage location in the dialog
- ▶ Enter the file name
- ▶ Click **Save**
- > The file is saved.

12.2.6 Configuration view

You can edit individual values of displayed encoder configuration in the **Configuration** view.

- ▶ Click the **Configuration** tab to call this view

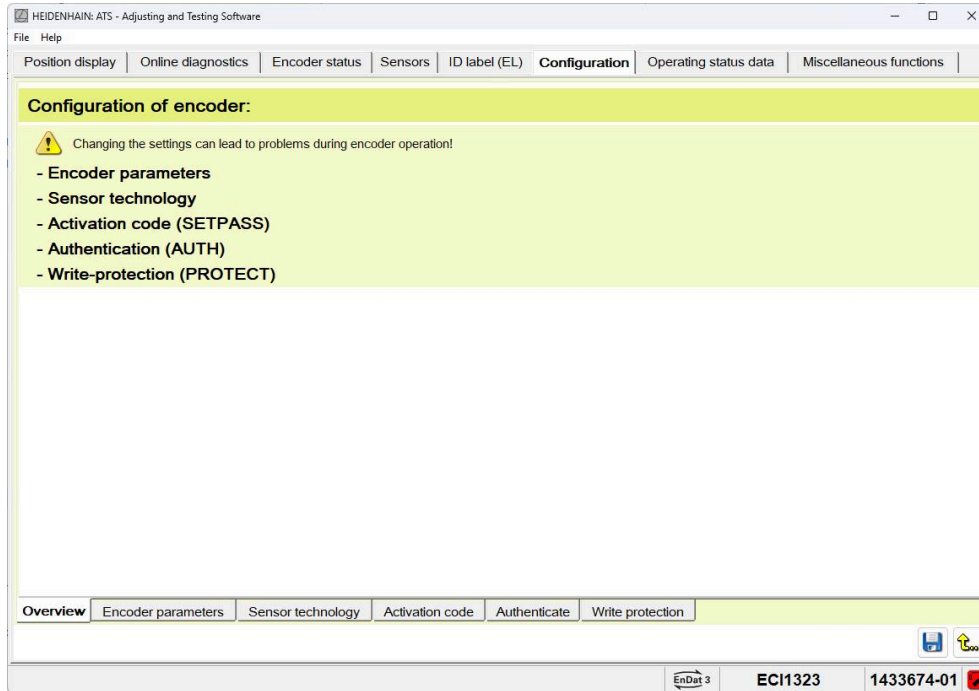





Figure 162: **Configuration** view

The editable parameters are grouped. The overview shows the available groups.

-  Switchover of data transfer rate is currently not supported.
-  Access protection (write or read protection) may be set for individual functions or values. The access rights are protected by password authentication. If the required access rights are missing, the Adjusting and Testing Software displays a corresponding message.
-  For more information on EnDat 3 visit: www.endat.de.

Operating elements

Symbol	Function
	<p>Save file</p> <p>Opens the dialog for saving the log to a PDF file</p> <p>Further information: "Saving log data", Page 333</p>

Assigning the bus address

In the **Bus operation** view, you can repeat the address assignment for the entire bus chain. If the testing device is only connected to a single encoder, you can set the bus address manually.

i Each time you connect to a bus chain with several participants, the Adjusting and Testing Software automatically repeats the automatic address assignment. Manual changes are overwritten in the encoder memory. Errors in bus addressing can be avoided this way.

- ▶ Click the **Configuration** tab to call this view
- ▶ Click the **Bus operation** tab in the lower navigation bar

Automatic address assignment

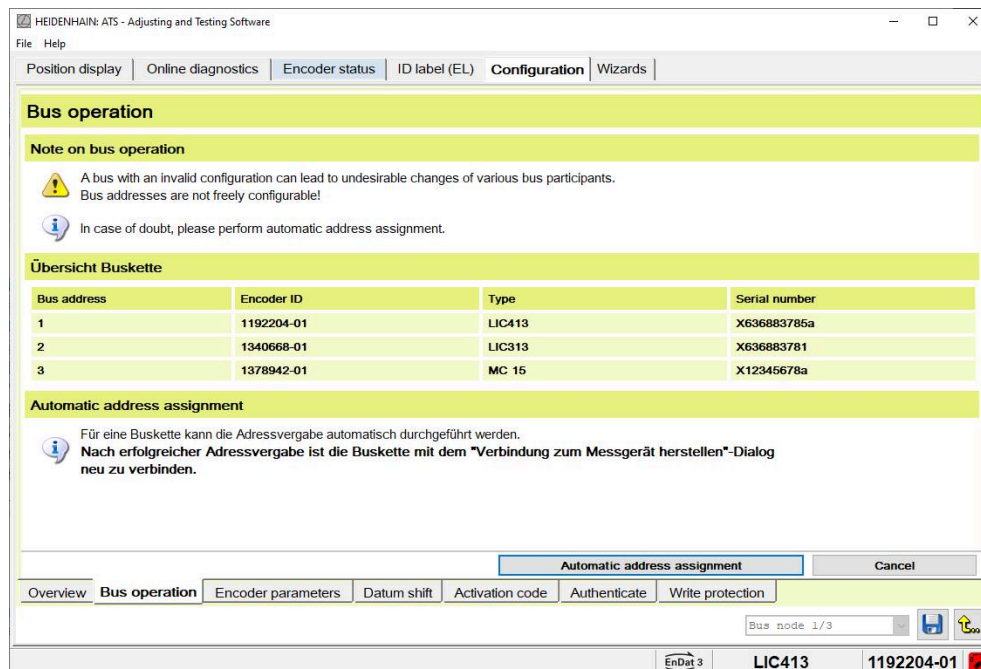

Figure 163: **Bus operation** screen with multiple participants

- ▶ Click **Automatic address assignment** to start automatic address assignment
- ▶ The bus is checked and automatic address assignment performed.
- ▶ The new bus addresses are written to the encoder memory.
- ▶ Confirm with **OK** when address assignment is complete
- ▶ The connection to the bus chain is separated automatically.

Manual address assignment

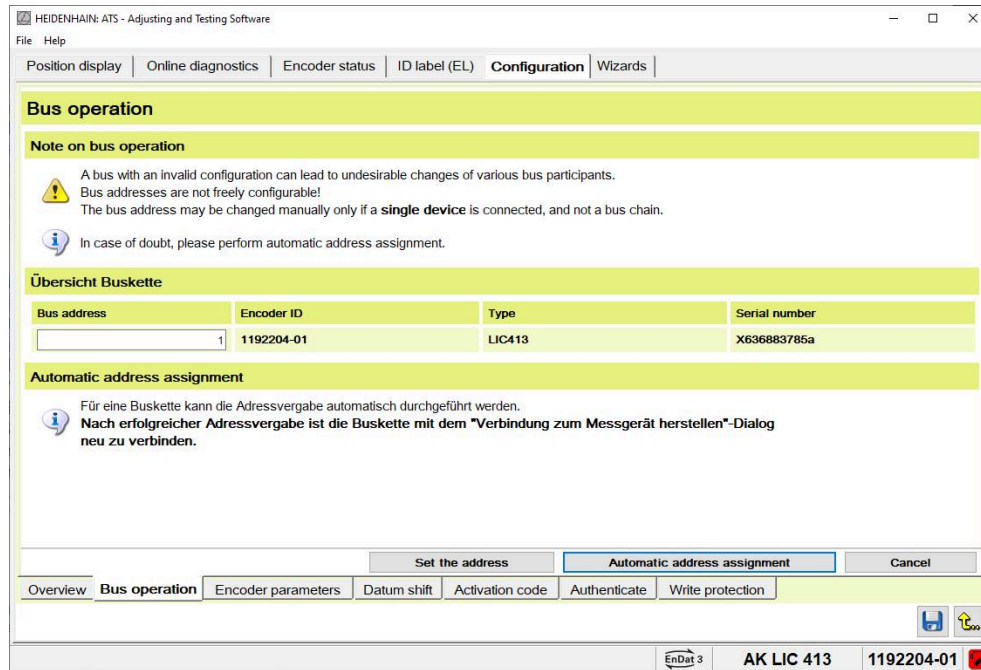

Figure 164: **Bus operation** screen with only one participant

- ▶ Enter the desired value in the **Bus address** field
- ▶ Click **Set the address**
- ▶ The new bus address is written to the encoder memory.
- ▶ Confirm with **OK**

Changing the encoder parameters

In the **Encoder parameters** view, you can check the bus address and the axis address of the connected encoder.

- ▶ Click the **Configuration** tab to call this view
- ▶ Click the **Encoder parameters** tab in the lower navigation bar

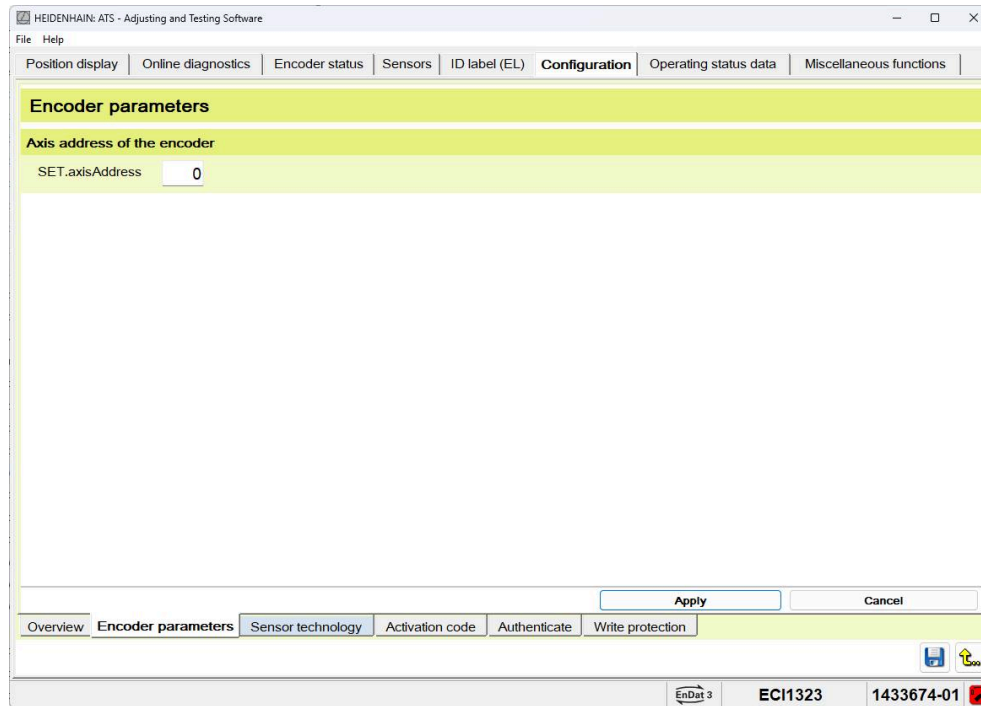

Figure 165: **Encoder parameters** view

- ▶ Enter the desired values in the input fields
- ▶ Click **Apply** to transfer the changes to the encoder

Setting a datum shift

In the **Datum shift** view, you can shift the datum of the connected encoder. The datum shift enables you to adapt the encoder to the machine for each individual axis (e.g., for measuring the rotor position on synchronous motors).

Precondition: The encoder supports datum shift.

- ▶ Click the **Configuration** tab to call this view
- ▶ Click the **Datum shift** tab in the lower navigation bar

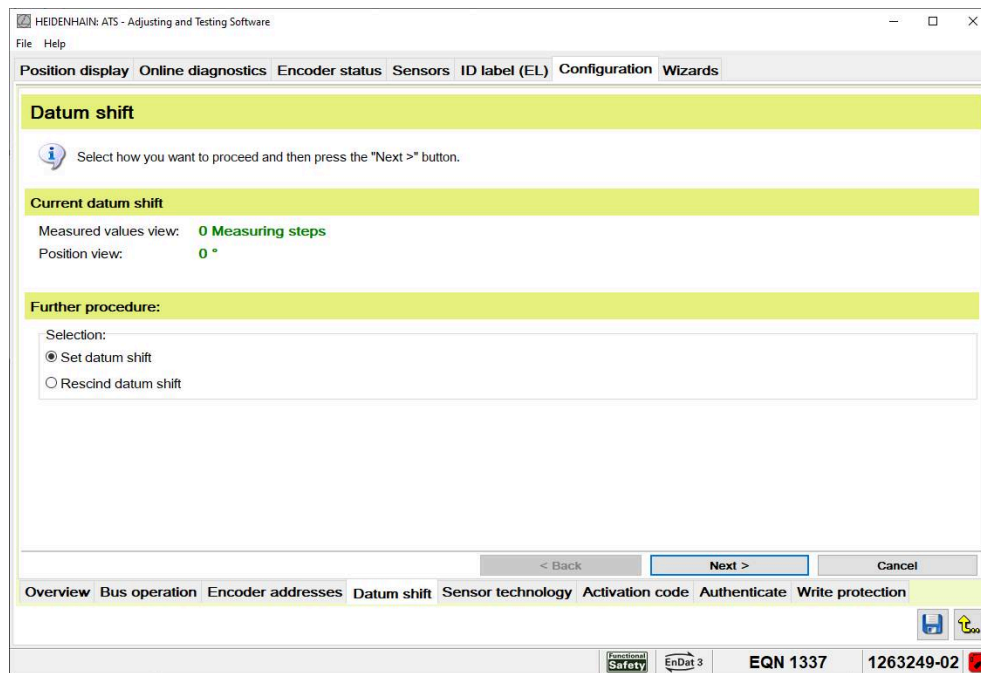

Figure 166: **Datum shift** view

WARNING

Danger of uncontrolled axis movements due to datum shift!

If you select an incorrect value for datum shift, uncontrolled movements of the machine axes may occur. This may result in death, serious injuries, or damage to equipment.

- ▶ Observe the documentation of the machine tool and the encoder
- ▶ Change the datum shift only if absolutely necessary (e.g. if the encoder is exchanged)
- ▶ Shift the datum only while the encoder is at a standstill
- ▶ Leave the traverse range of the machine before setting a datum shift
- ▶ Cancel any datum shift before setting a new one

WARNING

Danger from falling machine axes!

Non-secured vertical or hanging machine axes may fall down due to datum shift. This may result in death or serious injuries.

Before setting a datum shift:

- ▶ Secure the machine axes
- ▶ Leave the traverse range of the machine

 For linear encoders, select the datum such that only position values > 0 are output.

 A datum shift may require a new acceptance test (e.g., in the case of functionally safe applications).

 Cancel any existing datum shift before setting a new one.
Further information: "Canceling datum shift", Page 308

The following options are available for setting a datum shift:

- **Set datum to current position:**
Approach the desired position and adopt this position as zero point
- **Set datum to absolute position:**
Enter the desired position value manually

 Which options are available for the datum shift depends on the connected encoder.

Setting the datum to current position

- ▶ Click the **Datum shift** tab in the lower navigation bar
- ▶ In the **Further procedure** section, select the option **Set datum shift**
- ▶ Click **Next**
- ▶ The Adjusting and Testing Software displays information on the datum shift.
- ▶ Click **Yes**
- ▶ The Adjusting and Testing Software shows the current position in the **POS1** section.
- ▶ Move to the desired position
- ▶ In the **Type of datum shift** section, select the option **Current position**

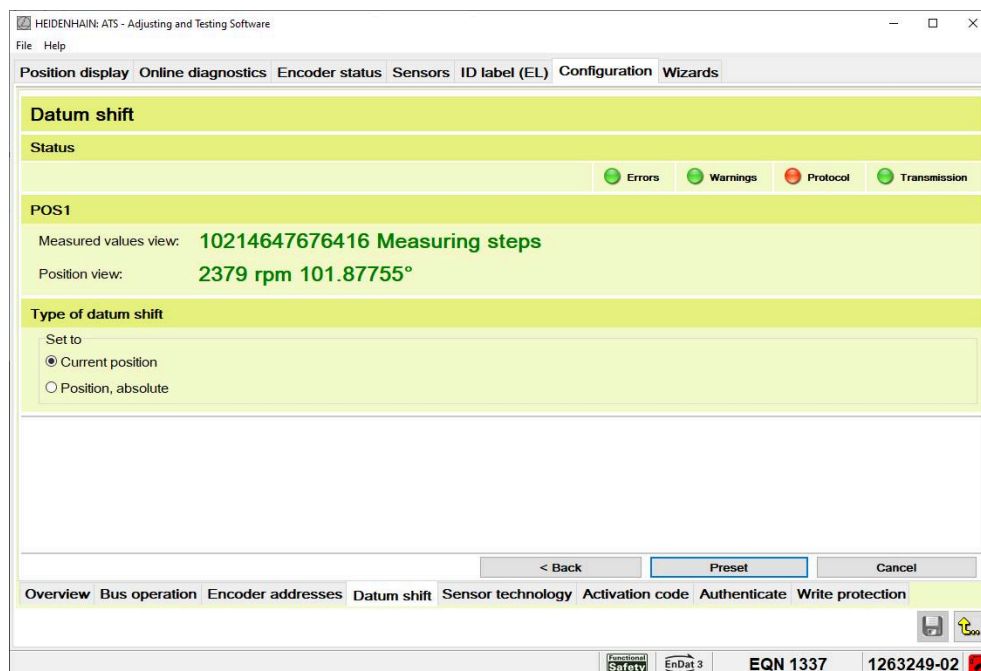

Figure 167: **Current position** option selected in the **Datum shift** view

- ▶ Click **Preset** to transfer the change to the encoder
- ▶ The current position is saved in the encoder as the new datum.

Setting the datum to absolute position

- ▶ Click the **Datum shift** tab in the lower navigation bar
- ▶ In the **Further procedure** section, select the option **Set datum shift**
- ▶ Click **Next**
- ▶ The Adjusting and Testing Software displays information on the datum shift.
- ▶ Click **Yes**
- ▶ The Adjusting and Testing Software shows the current position in the **POS1** section.
- ▶ In the **Type of datum shift** section, select the option **Position, absolute**

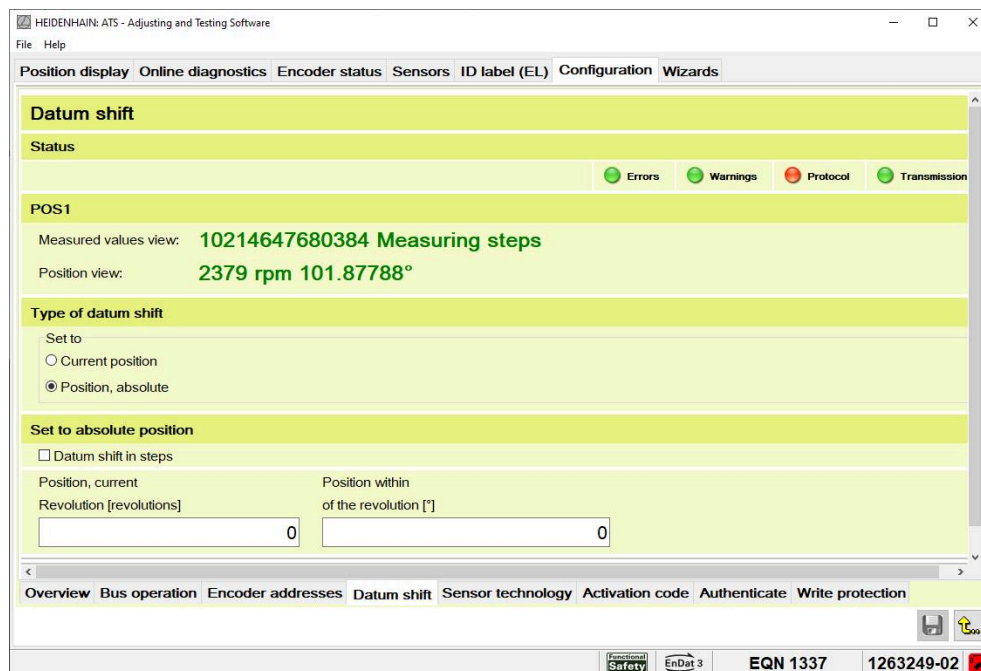

Figure 168: **Position, absolute** option selected in the **Datum shift** view

- ▶ The **Set to absolute position** section is displayed.
- ▶ The unit used in the input fields depends on the encoder: micrometers or degrees and, if necessary, revolutions.
- ▶ To change the unit to increments, set the check mark at **Datum shift in steps**

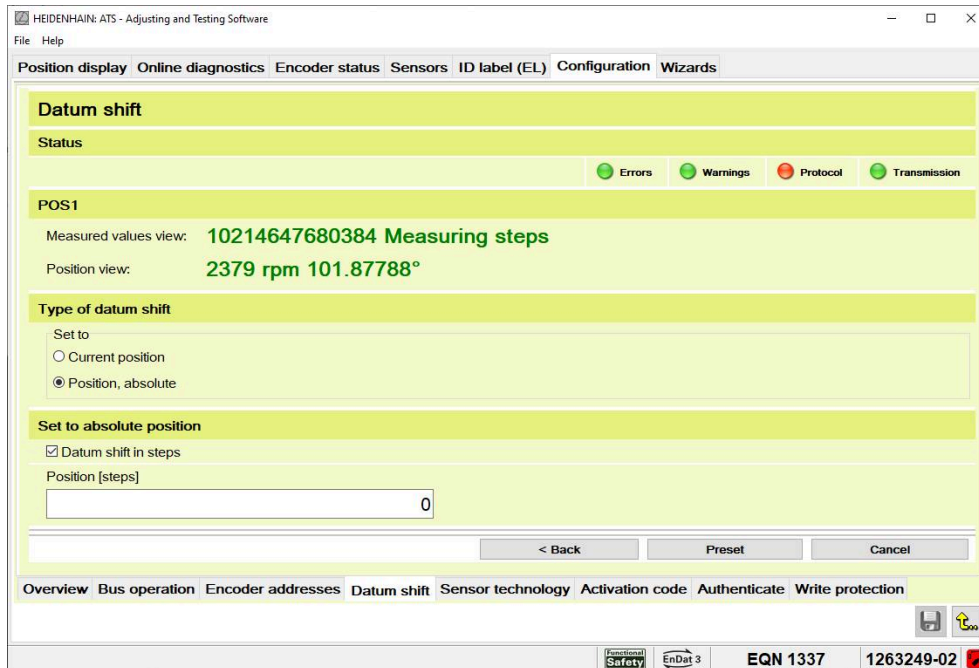



Figure 169: **Datum shift in steps** option selected in the **Datum shift** view

- ▶ Enter the position value in the correct unit
- ▶ Click **Preset** to transfer the change to the encoder
- > The current position is saved in the encoder as the new datum.

Canceling datum shift

In the **Datum shift** view, you can reset the datum to the default condition of the encoder.

- ▶ Click the **Configuration** tab to call this view
- ▶ Click the **Datum shift** tab in the lower navigation bar
- > The current datum is shown in the **Current datum shift** section.

 If the displayed value is not zero, then a datum shift is active.

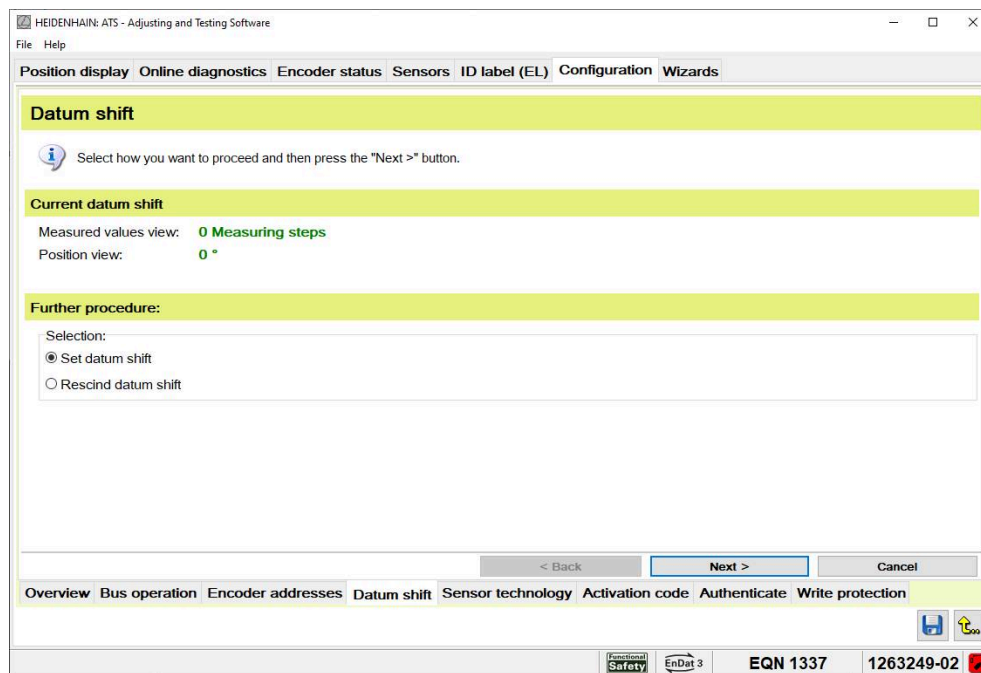

Figure 170: **Datum shift** view with active datum shift

- ▶ In the **Further procedure** section, select the option **Rescind datum shift**
- ▶ Click **Next**
- > The Adjusting and Testing Software displays information on the datum shift.
- ▶ Click **Yes**
- ▶ Click **Yes** to transfer the change to the encoder
- > The datum shift is reset.

Adapting sensor parameters

In the **Sensor technology** screen, you can adapt the sensor parameters (depending on the encoder).

- ▶ Click the **Configuration** tab to call this view
- ▶ Click the **Sensor technology** tab in the lower navigation bar

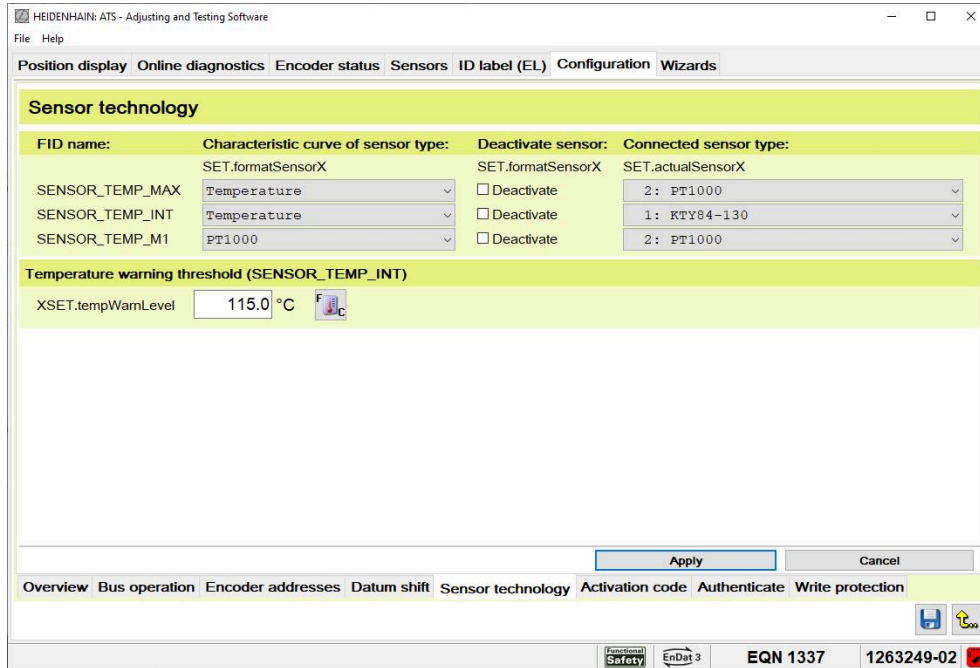



Figure 171: **Sensor technology** view

i A rotary encoder with an external and an internal temperature sensor is shown in the example. The sensors and values that are displayed in the **Sensor technology** view depend on the connected encoder.

b For more information on EnDat 3 visit: www.endat.de.

Display	Description
FID name	Sensor name (FID = Frame Identifier)
SENSOR_TEMP_MAX	Transfers the highest measured value of the sensors SENSOR_TEMP_M1, SENSOR_TEMP_M2 and SENSOR_TEMP_M3 Default setting: Temperature The setting "Reserved" is currently not supported and has no effect.
SENSOR_TEMP_INT	Transfers the measured value of an internal temperature sensor. Default setting: Temperature The setting "Reserved" is currently not supported and has effect.

Display	Description
SENSOR_TEMP_M1	Transfers the measured value of an external temperature sensor
SENSOR_TEMP_M2	
SENSOR_TEMP_M3	
	Selection of the evaluation characteristic for the temperature sensor concerned (sensor-dependent)
	<div style="border: 1px solid black; padding: 5px;">  The setting "Reserved" is currently not supported and results in the transmission of invalid data. </div>
Characteristic curve of sensor type	Selection of the evaluation characteristic supported by the sensor, for temperature sensor; examples for temperature sensors: KTY84-130 or PT 1000
Deactivate sensor	Deactivates the sensor; the encoder does not transmit values measured by the sensor. "Deactivated" is displayed for the sensor in the Sensors view and in the ID label (EL) view.
Connected sensor type	The installed sensor type is displayed. The value is for information only and has no functional effect. The value "0: Not specified" indicates that no information is available on the sensor type.
Temperature warning threshold (SENSOR_TEMP_INT)	Setting of the temperature value above which the encoder issues a warning

Operating elements

Symbol	Function
	Display of measured value in degrees Celsius or Fahrenheit Switches the measured value display from Celsius to Fahrenheit or vice versa

Adapting parameters

- ▶ For external temperature sensors, select the corresponding characteristic curve in the **Sensor type** column
- ▶ To deactivate the data transmission for individual sensors, check the box in the **Deactivate sensor** column
- ▶ If necessary, enter the desired value in the **Temperature warning threshold (SENSOR_TEMP_INT)** section
- ▶ Click **Apply** to transfer the changes to the encoder

Switching the unit

- ▶  Click **Show measured value in degrees Celsius or Fahrenheit** in the control bar to switch temperature displays between Celsius and Fahrenheit

Setting and changing the activation code (SETPASS)

In this view you can set the activation code for the authentication of a user level or change an already existing activation code. You can enter the activation code directly, or use a .BAT file for calculation. If an activation code is successfully set or changed, authentication is carried out automatically with the corresponding user level.

- ▶ Click the **Configuration** tab to call this view
- ▶ Click the **Activation code (SETPASS)** tab in the lower navigation bar

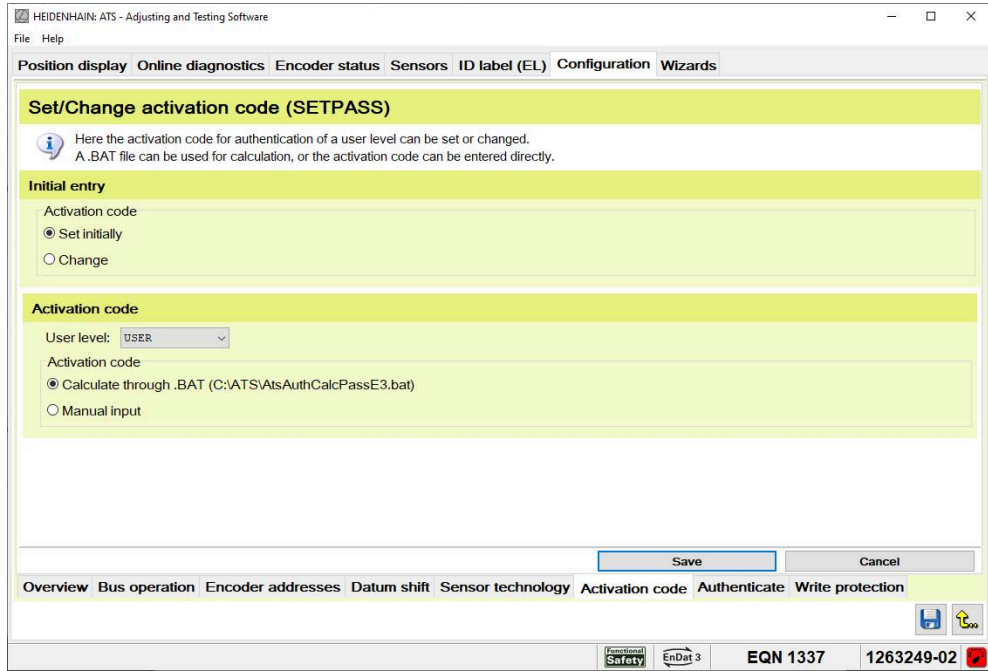

Figure 172: Set activation code (SETPASS) screen

Display	Description
User level	Drop-down list for selecting the desired user level (OEM2 or OEM1). No authentication takes place in the USER level, since the device always is in the USER level after booting.

Display	Description
Activation code – Calculate through .BAT (C:\ATS\AtsAuth-CalcPassE3.bat)	<p>Create a .BAT file with the name AtsAuthCalcPassE3.bat in <i>C:\ATS\AtsAuthCalcPassE3.bat</i>.</p> <p>The .BAT file contains a calculation algorithm, a link, or a fixed password. The machine tool builder must define this.</p> <p>The file is called by the Adjusting and Testing Software and outputs a password.</p> <p>It is recommended to define the algorithm on the basis of the serial number of the encoder, as this is a unique number. The serial number is available as a transfer parameter in the .BAT file along with other information.</p> <ul style="list-style-type: none"> ■ Transfer parameter: String with EL.deviceSerial, EL.deviceIdent, EL.deviceName ■ Return parameter: Password as a decimal number with 32 bits maximum <p>An example of the .BAT file (only the frame, without the algorithm) can be found in the file path where the information about the logs is stored.</p> <p>Further information: "Saving log information", Page 57</p>
Activation code – Manual input	<p>Manual input of a number (32 bits max.) in the input window</p>

Setting the activation code once

- ▶ Click **Set initially** at **Initial entry**
- ▶ Select your preferred user level
- ▶ Click **Calculate through .BAT** at **Activation code**
or
- ▶ Click **Manual input**. Here you can enter a new activation code in the input window
- ▶ Click **Save**
- ▶ The result is shown in a corresponding message.

Changing the activation code

- ▶ Click **Change** at **Initial entry**
- ▶ The menu for entering the old activation code is displayed.
- ▶ In the **Old activation code** field, select the user level of the old activation code
- ▶ Click **Manual input**. Here you can enter the old activation code in the input window
- ▶ In the **Activation code** field, select the user level for the new activation code. For authentication, at least the same or a higher user level (OEM2, OEM1) must be selected in the **Old activation code** field
- ▶ Click **Calculate through .BAT** at **Activation code**
or
- ▶ Click **Manual input**. Here you can enter a new activation code in the input window
- ▶ Click **Save**
- ▶ The result is shown in a corresponding message.

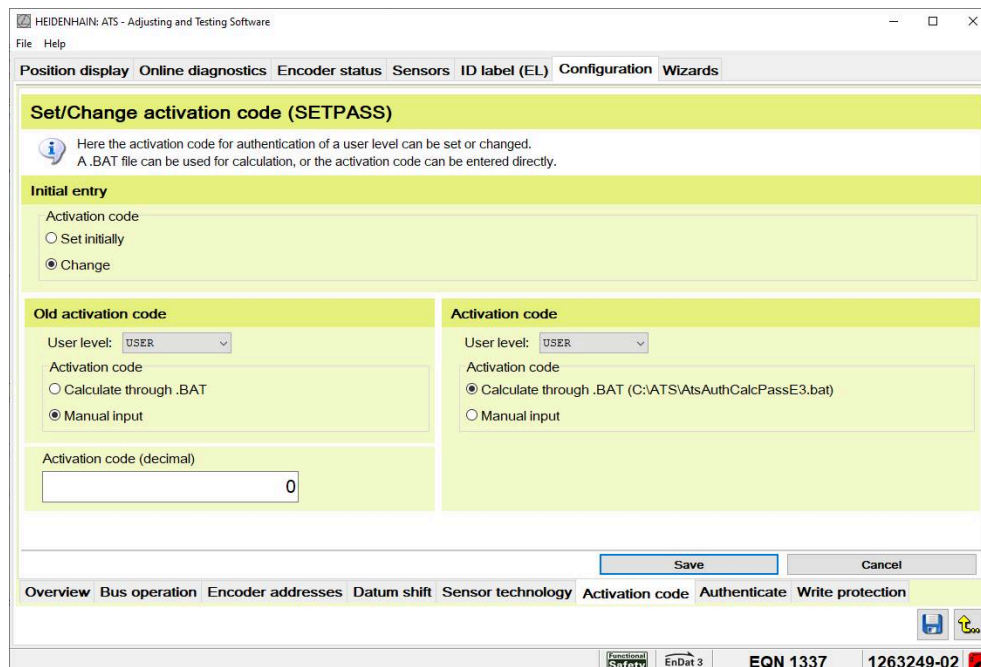
Figure 173: **Change activation code** screen

Authentication (AUTH)

In this view you can enter an activation code to authenticate yourself for an encoder. The current user level can be changed. The activation code can be typed in as a password. Automatic password generation via a .BAT file is also possible.

Further information: "Setting and changing the activation code (SETPASS) ", Page 311

- ▶ Click the **Configuration** tab to call this view
- ▶ Click the **Authenticate (AUTH)** tab in the lower navigation bar

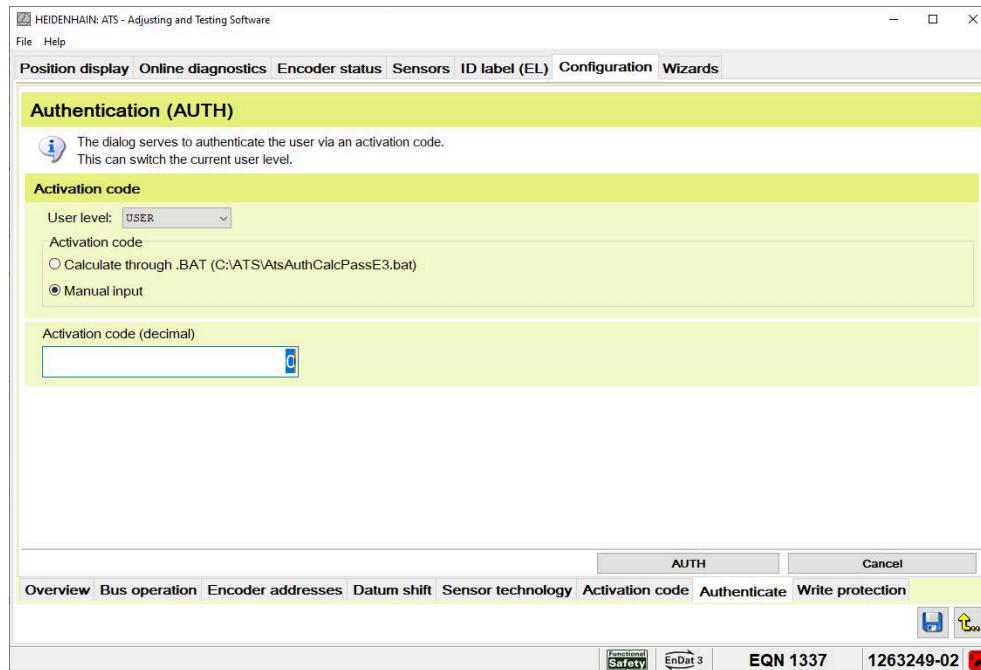

Figure 174: **Authentication (AUTH)** screen

To authenticate:

- ▶ Click the drop-down list for the user level
- > The selection menu opens.
- ▶ Select the desired user level
- ▶ Click **Calculate through .BAT** at **Activation code**
or
- ▶ Click **Manual input** to enter a number in the input field
- ▶ Click **AUTH**
- > Authentication starts.
- > The result is shown in a corresponding message

Setting write-protection (PROTECT)

In this view you can set write protection for specific memory areas. First, you must authenticate yourself with the appropriate access level.

- ▶ Click the **Configuration** tab to call this view
- ▶ Click the **Write protection (PROTECT)** tab in the lower navigation bar

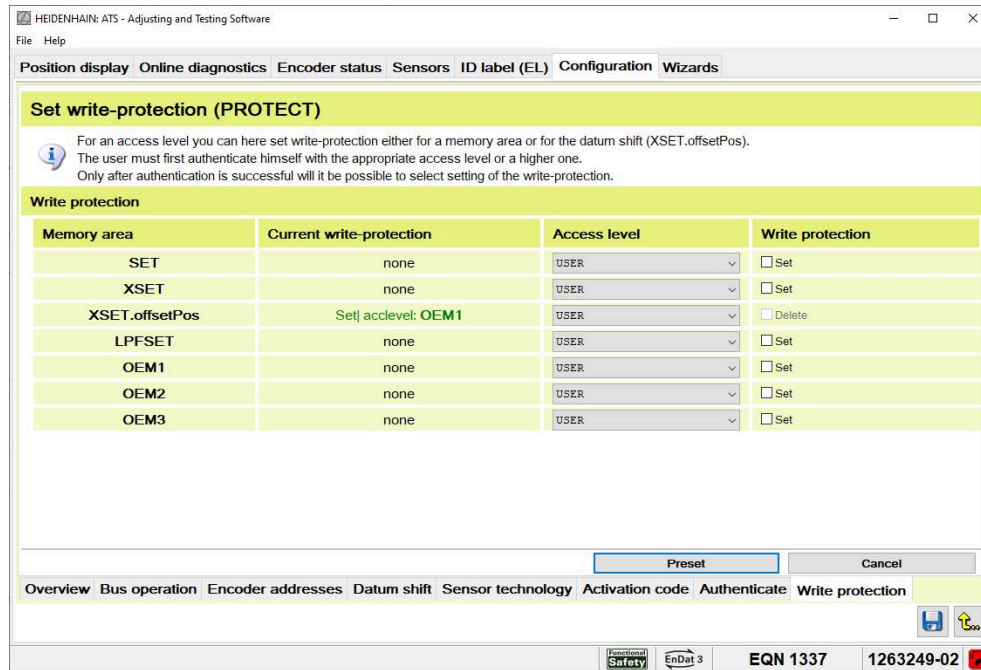

Figure 175: Set write-protection (PROTECT) screen

Column	Description
Memory area	Memory areas for which read or write protection can be set
Current write-protection	Display of the current write protection of the memory area
Access level	Selection of the access level with which write protection is set for the respective memory area. Authentication is required before selecting the access level (Further information: "Authentication (AUTH)", Page 314). The access level you used for authentication is automatically selected for all memory areas.

Column	Description
Write protection / read protection	<p>Set or delete the read or write protection for the respective memory area.</p> <p>Please note:</p> <ul style="list-style-type: none"> ■ The checkbox is disabled if the authentication level is lower than the authentication of the access level ■ The checkbox is disabled if the access level of an active read or write protection is higher than the current authentication level ■ The access level of an existing write protection / read protection cannot be increased. Delete the write protection / read protection and set it again ■ Datum shift can be protected with an access level different from that of the XSET area. This only works if the datum shift is set first (or at the same time as the XSET area). If the entire XSET area is protected first, the datum shift can no longer be protected separately afterwards

To set write-protection or read-protection:

- ▶ Click the drop-down list in the **Access level** column of the desired **memory area**
- > The selection menu opens
- ▶ Select the access level
- ▶ Click **Set** for the desired **memory area** in the column **Write protection / Read protection**
- > The result is shown in a corresponding message



Setting write protection—and in particular read protection—may cause problems when operating the encoder. Therefore, the MANUFACTURER access level cannot be set for read protection.

12.2.7 Wizards view

In the **Wizards** view, you can start the wizard-assisted procedures, for example the Functional-safety encoder check (depending on the encoder).

- ▶ Click the **Wizards** tab to call this view

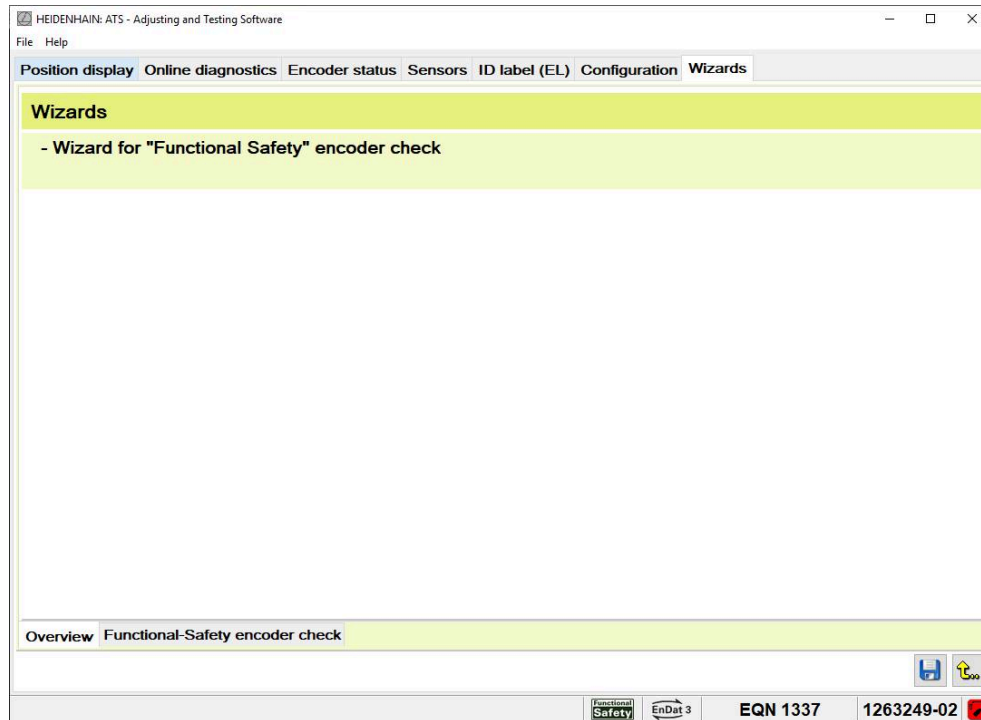

Figure 176: **Wizards** view

The overview shows the available wizards.

- ▶ Click the corresponding tab in the lower navigation bar to start a wizard

Checking the functional safety of the encoder

You can use the wizard for the **Functional-safety encoder check** to check safety-relevant functions of encoders. The wizard guides you through the required steps.

- i** You can see from the ID label on the encoder whether the encoder supports functional safety.
Further information: "ID label", Page 62
- i** If the functional-safety encoder check results in errors, the encoder does not comply with the functional safety specifications. Repairs may be carried out only by the HEIDENHAIN Service department.
- i** After installing and exchanging functional safety components, repeat the acceptance test according to the specifications of the machine tool builder.
- M** For more information on EnDat 3 visit: www.endat.de.

- ▶ Click the **Wizards** tab
- > Click the **Functional-safety encoder check** tab in the lower navigation bar
- > The **Functional-safety encoder check** starts
- > The Adjusting and Testing Software checks the safety-relevant memory areas

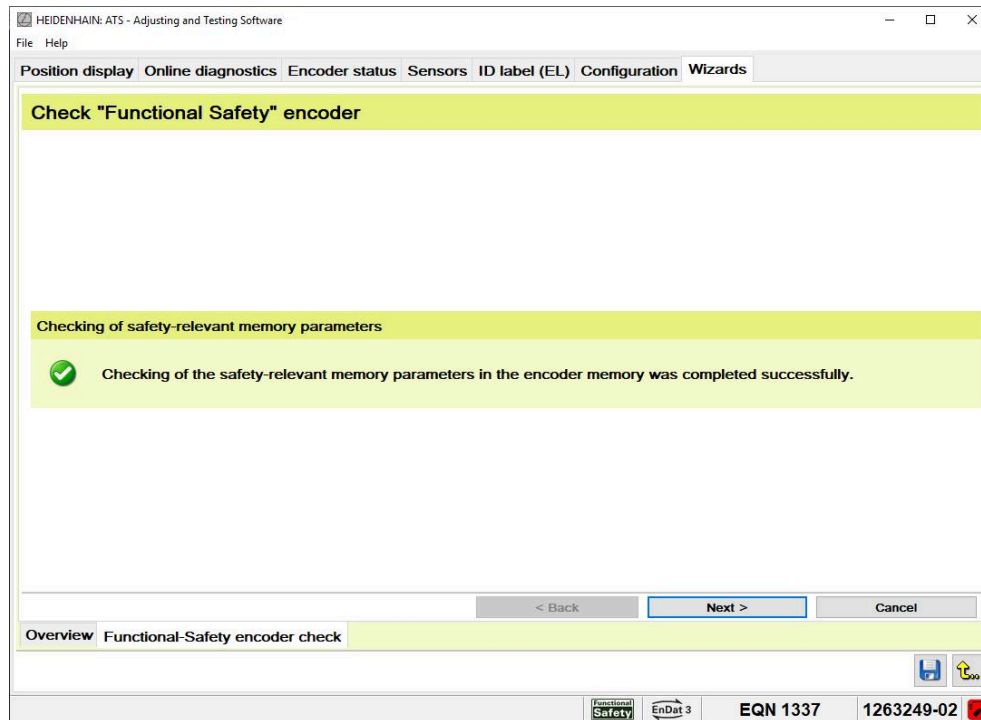

Figure 177: Checking of safety-relevant memory parameters

Checking of safety-relevant memory parameters

The Adjusting and Testing Software checks the safety-relevant memory parameters (XEL.safetyCsPos1 check) for consistency.

- > The wizard shows the result of the memory comparison
- ▶ Click **Next** to continue
- > The wizard shows information on the **test for consistency**

Checking of functional safety

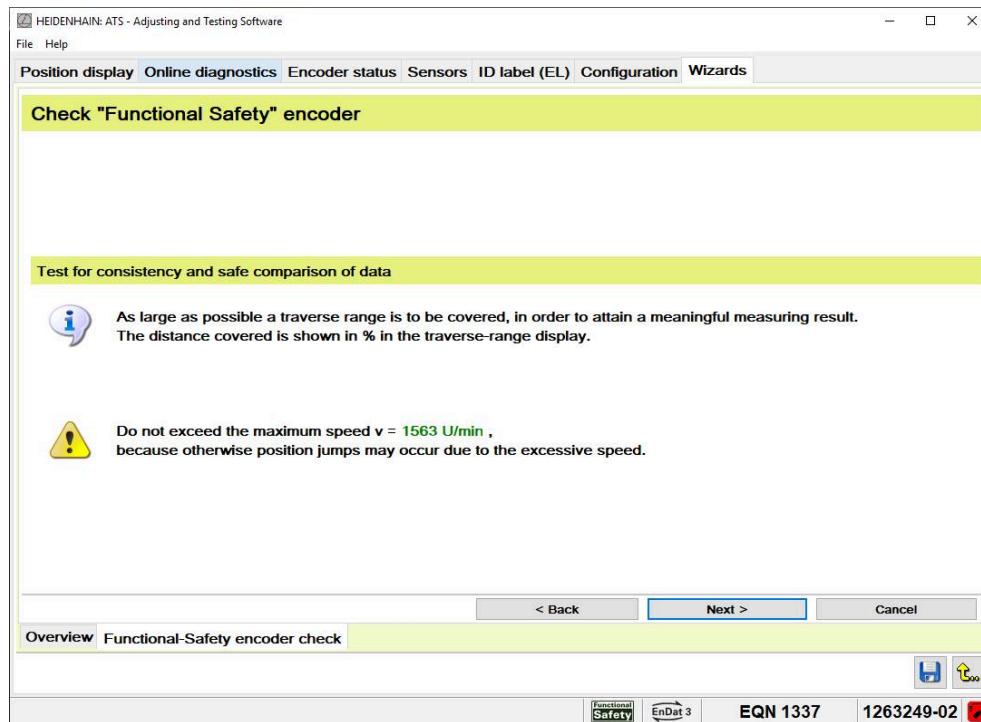

Figure 178: Notes on the inspection

The **functional-safety check** comprises the following tests:

- CSS test
- SOL test
- SF status
- AA test
- Data test
- WD test
- FDS test (forced dynamic sampling; testing of the monitoring function in the encoder)

A test for consistency is performed in addition: Encoders supporting functional safety output two position values: The high-resolution position 1 and a lesser resolved position 2. During the test for consistency, the Adjusting and Testing Software scales the position value 1 to the resolution of position value 2 and checks the consistency of the two values. The test is considered passed if the maximum position jump results in a deviation ≤ 1 .

- ▶ Click **Next** to continue
- > The wizard displays the screen for running the measurement

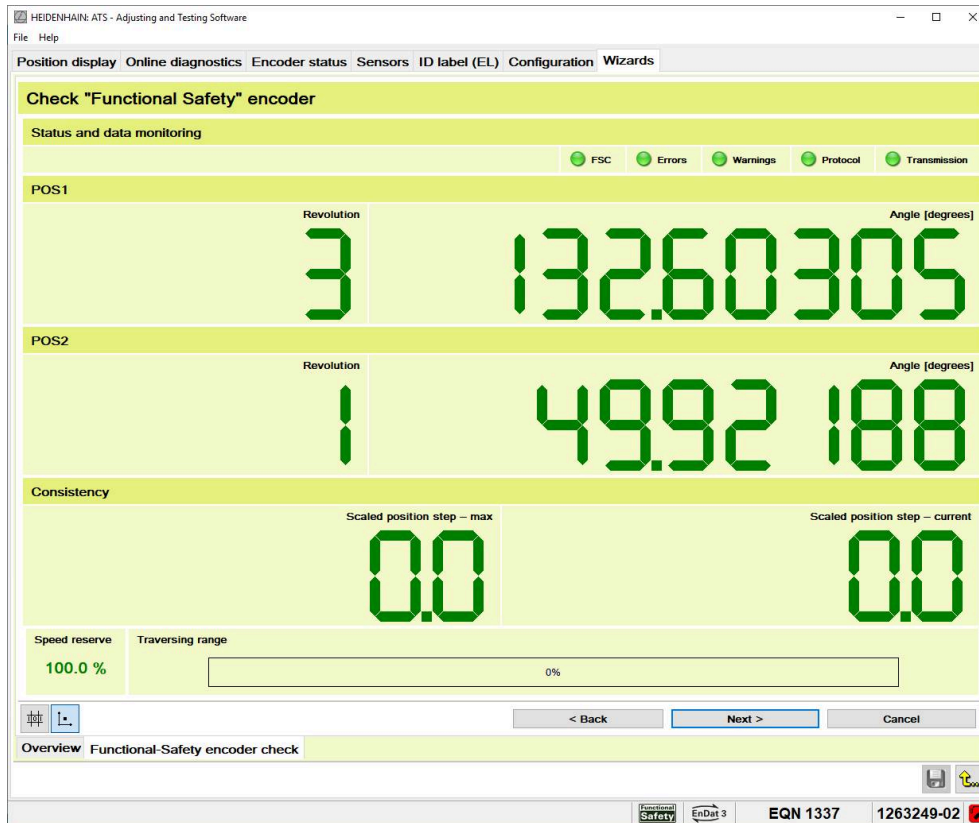

Figure 179: Measurement view of the test for consistency



Depiction	Description
Status and data monitoring	Further information: "Description of the status displays", Page 281
POS1	Position value1, high resolution
POS2	Redundant position value 2, lower resolution POS2 is transmitted inverted. However, to simplify the display, POS2 is not shown inverted.
Consistency	Deviation detected during the measurement <ul style="list-style-type: none"> ■ Scaled position step – max: Maximum deviation ■ Scaled position step – current: Current deviation
Speed reserve	Remaining speed reserve until the maximum traversing speed is reached Unit: Percent



A speed reserve of 0% means that the maximum traversing speed has been reached. The maximum traversing speed must not be exceeded, as this could cause position jumps.

Depiction	Description
Traversing range	Traversing distance covered Unit: Percent The traverse path is read out from the encoder memory or the encoder database (depending on the encoder).

Operating elements

Symbol	Function
	Show measured values Displays the measured value in increments
	Show position values Converts the measured value into a position value Unit: micrometers or degrees (depending on the encoder)

- ▶ Traverse the entire measuring range
- > The progress bar shows the traversed distance in percent

 The traverse path of encoders mounted to a machine may be limited such that the progress bar cannot reach 100%. In this case check the longest possible traverse path.

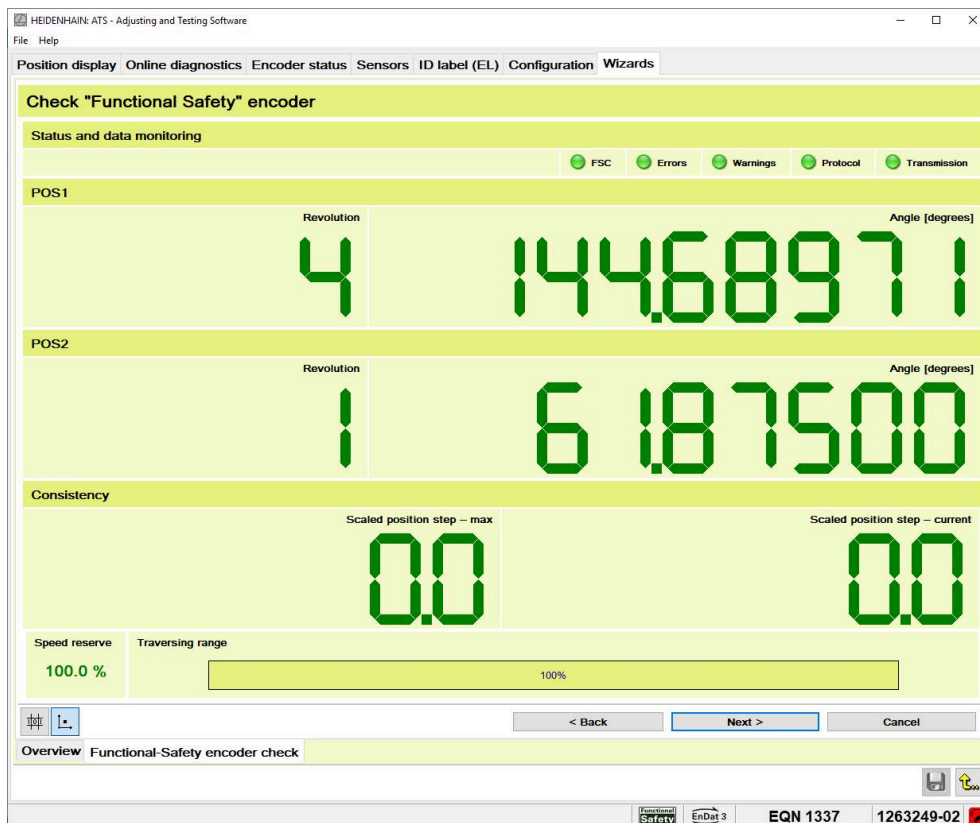

Figure 180: Result of the test for consistency

i You can switch the counter display between measured values view and position view.

Further information: "Switching between measured values view and position view", Page 283

- ▶ Click **Next** to continue
- ▶ The wizard displays the results of the functional-safety encoder check

Results of the functional-safety encoder check

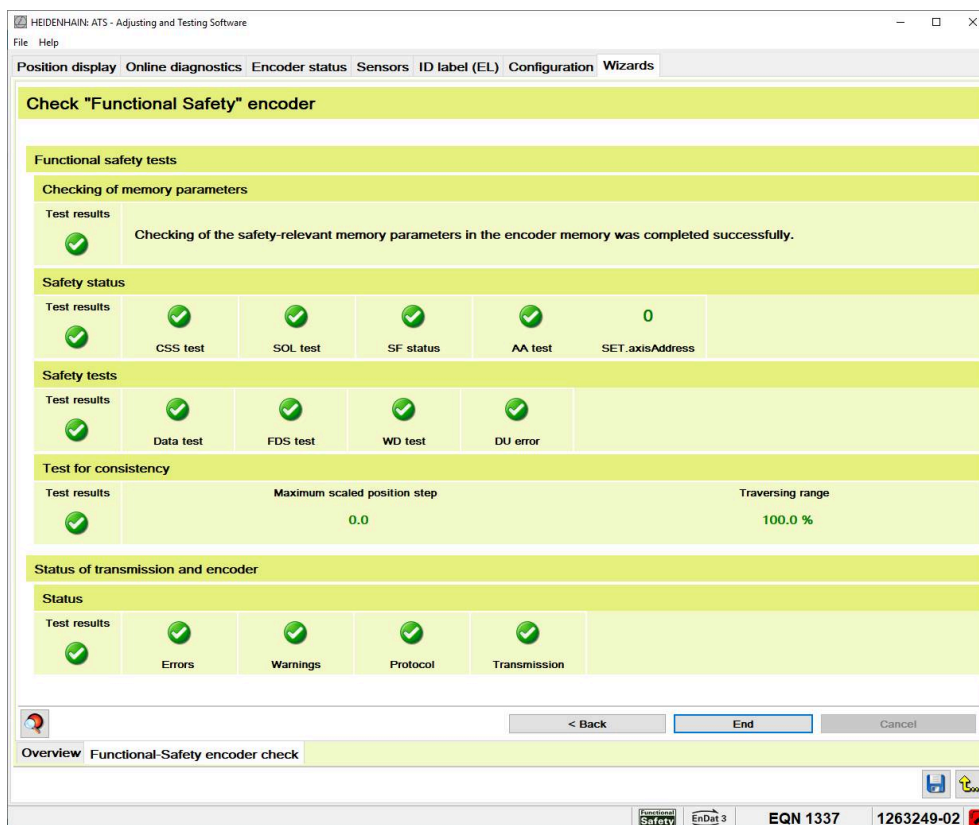



Figure 181: Results of the functional-safety encoder check

The overview shows the results of the functional-safety encoder check. The overview is subdivided into the following sections:

- **Functional safety tests:** Functions required for functional safety
- **Status of transmission and encoder:** Functions that have no effect on functional safety

Depiction	Description
Checking of memory parameters	Result of memory comparison
Safety status	Status check of the safety packets
Safety tests	Complex test sequences (e.g., testing over several sampling cycles or safety packets) <ul style="list-style-type: none"> ■ DU error: Internal safety-relevant encoder errors



Depiction	Description
Test for consistency	<p>Result of the test for consistency</p> <ul style="list-style-type: none"> Max. difference: Maximum deviation of the scaled position value 1 from position value 2 Traversing range: Measuring distance traversed during the test Unit: Percent <div style="border: 1px solid black; padding: 5px; margin-top: 10px;"> <p> If the captured area is less than 5%, the result is displayed in red. However, for an evaluation of the encoder in the specific application, the maximum traversing range needs to be examined.</p> </div>

Status of transmission and encoder	<div style="border: 1px solid black; padding: 5px;"> <p> The tests shown in the Status section correspond to the status indicators of the Position display. Further information: "Status displays of the position display", Page 281</p> </div>
------------------------------------	---

 Red values or symbols indicate a malfunction of the encoder.



Symbols

Symbols are used to show the result of the respective test:

Symbol	Description
	<ul style="list-style-type: none"> Test completed without error
	<ul style="list-style-type: none"> Test found errors

The symbol in the first column represents the overall result of the line.

Operating elements

Symbol	Function
	<p>Show status information Displays a list of errors and warnings</p>
	<p>Save file Opens the dialog for saving the log to a PDF file Further information: "Saving log data", Page 333</p>

Show status information



- ▶ Click **Show status information** to display the status information provided by the encoder



If you click on the **Encoder status** tab instead, the functional-safety encoder check is terminated.

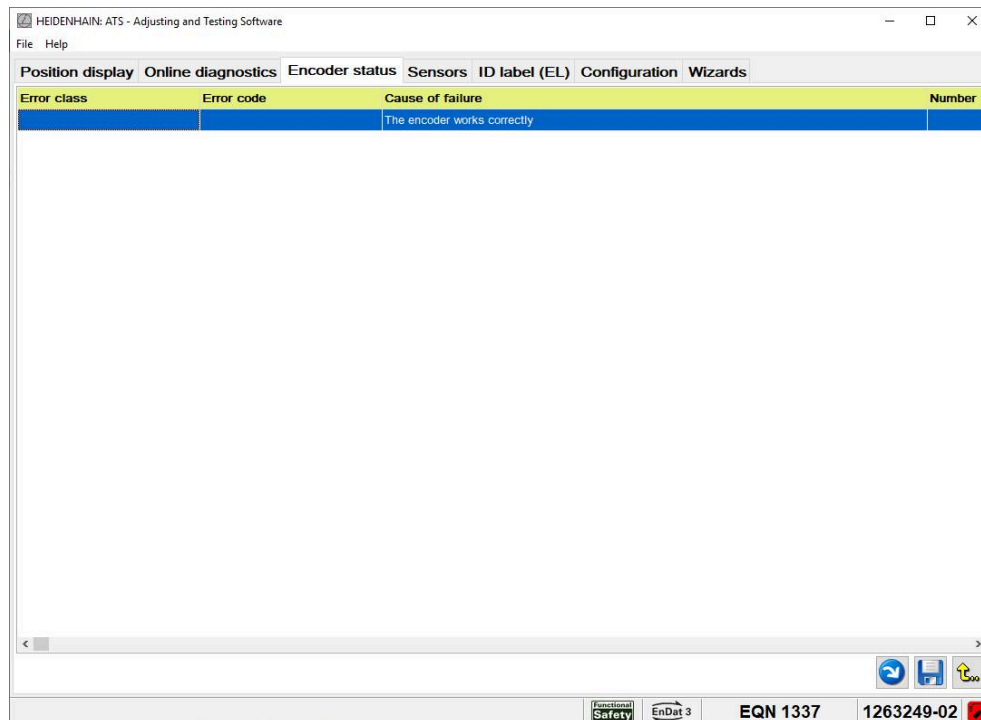

Figure 182: **Encoder status** screen

Operating elements

Symbol	Function
	Return to overview Returns to the results overview of the functional-safety encoder check
	Save file Opens the dialog for saving the log to a PDF file

Returning to the functional-safety encoder check



- ▶ Click **Return to overview** to return to the functional-safety encoder check

Procedure in the event of errors

If the functional-safety encoder check returns errors, proceed as follows:

- ▶ Abort the functional-safety encoder check and save the log
- ▶ Reset the status messages
Further information: "Resetting status messages", Page 294
- ▶ Repeat the functional-safety encoder check
- ▶ If errors are found again, contact the HEIDENHAIN Service

12.2.8 Operating status data view

The **Operating status data** screen shows information on the operating status and extreme values provided by the encoder. Depending on the encoder, further alarm-triggered data are transmitted.

- ▶ Click the **Operating status data** tab to call this view

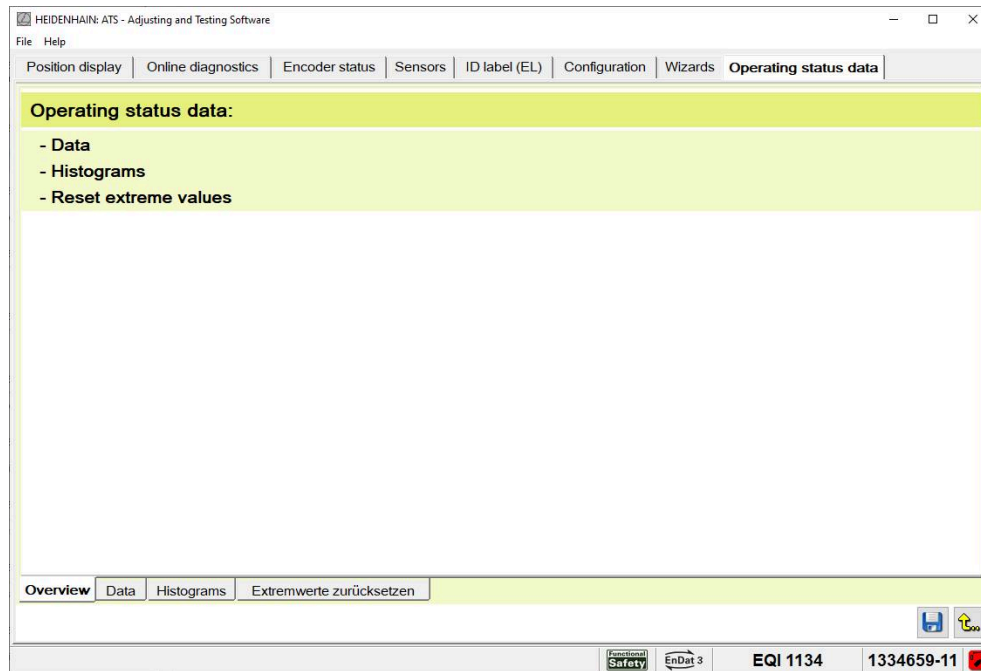

Figure 183: **Operating status data** view

The **Operating status data** tab comprises:

- **Overview**
 - **Data**
 - **Histograms**
 - **Reset extreme values**
- ▶ Click the desired tab in the lower navigation bar to switch between the views

Displaying data logger contents

- ▶ Click the **Data** tab to call the **Data contents of the data logger** view

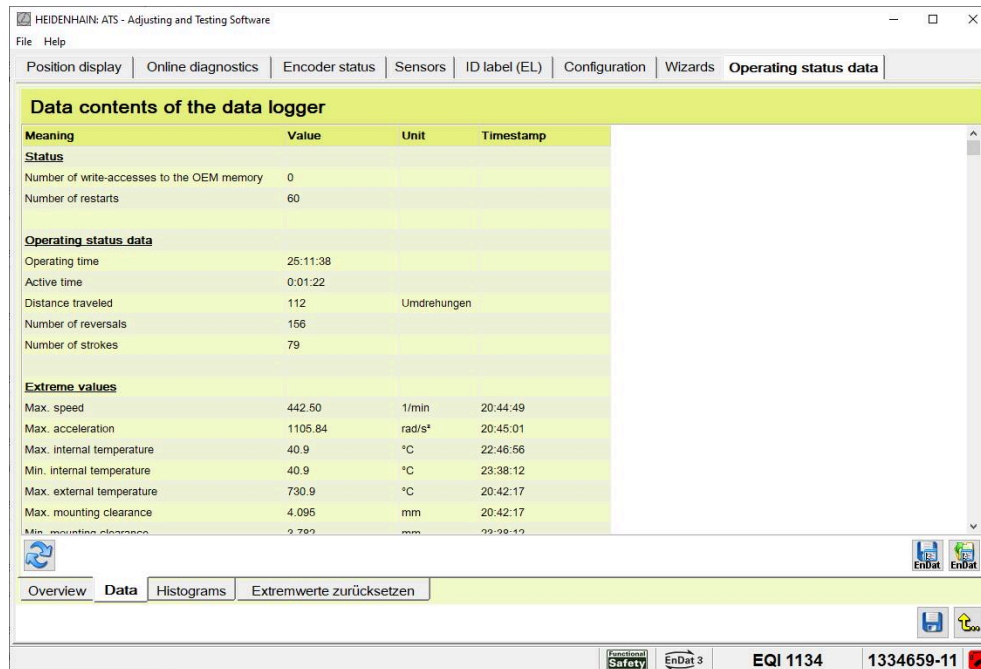

Figure 184: Data contents of the data logger view

Status section

Display	Description
Number of write-accesses to the OEM memory	Number of write-accesses to OEM1, OEM2, and OEM3 during the total operating time
Number of encoder restarts	Number of restarts during the total operating time

Operating status data section

Display	Description
Operating time	Total time the encoder was switched on
Active time	Time during which encoder was switched on and in motion
Distance traveled	Traverse path of the encoder during the total operating time
Number of reversals	Number of changes of direction of the encoder during the entire operating time
Number of strokes	Stroke definition: The moving encoder comes to a standstill and then continues to be moved in the same direction

Extreme values section

The encoder transmits the saved extreme values of the following measurands:

- Max. speed (absolute value)
- Max. acceleration (absolute value)
- Min. internal temperature
- Max. internal temperature
- Max. external temperature
- Max. mounting clearance
- Min. mounting clearance

You can reset the extreme values in the encoder memory.

Further information: "Resetting extreme values", Page 330

Alarm-triggered data section

The **Alarm-triggered data** section displays status-triggered data (depending on the encoder).



For more information on EnDat 3 visit: www.endat.de.

Refreshing data



- ▶ Click **Refresh data**
- > The encoder transmits the current data to the Adjusting and Testing Software
- > The display is refreshed

Displaying histograms

The Adjusting and Testing Software graphically displays measured values in the form of histograms. The type of histogram depends on the data and measured values transmitted by the connected encoder. The example described in this chapter explains the procedure.

- ▶ Click the **Histograms** tab to call the **Histograms of the data logger** view
- > The **Heatmap** is displayed

Heat map



Figure 185: **Data contents of the data logger** view with heat map

The **heat map** graphically depicts the distribution of the measured values and provides information on how often the encoder was in a certain speed range and temperature range.

Depiction	Description
X axis	Velocity Unit: depends on the encoder
Y axis	Temperature Unit: degrees
Green fields	The lighter the color of a field, the more measured values are in this range.
Gray fields	There are no or few measured values in this range.

To display the temperature range:

- ▶ Double-click a histogram in the **Heatmap**
- > The temperature range is displayed

Histograms T1 to T8 (example)

The example comprises the histograms **T1** to **T8**, which plot the data according to the specified temperature ranges:

- **T1:** -10 °C
 - **T2:** <15 °C
 - **T3:** <50 °C
 - **T4:** <85 °C
 - **T5:** <100 °C
 - **T6:** <115 °C
 - **T7:** <125 °C
 - **T8:** <=125 °C
- ▶ To switch between histograms, click on the selection menu where the current option is displayed (e.g., **Heatmap**)
 - ▶ Select the desired histogram
 - ▶ The selected histogram is displayed

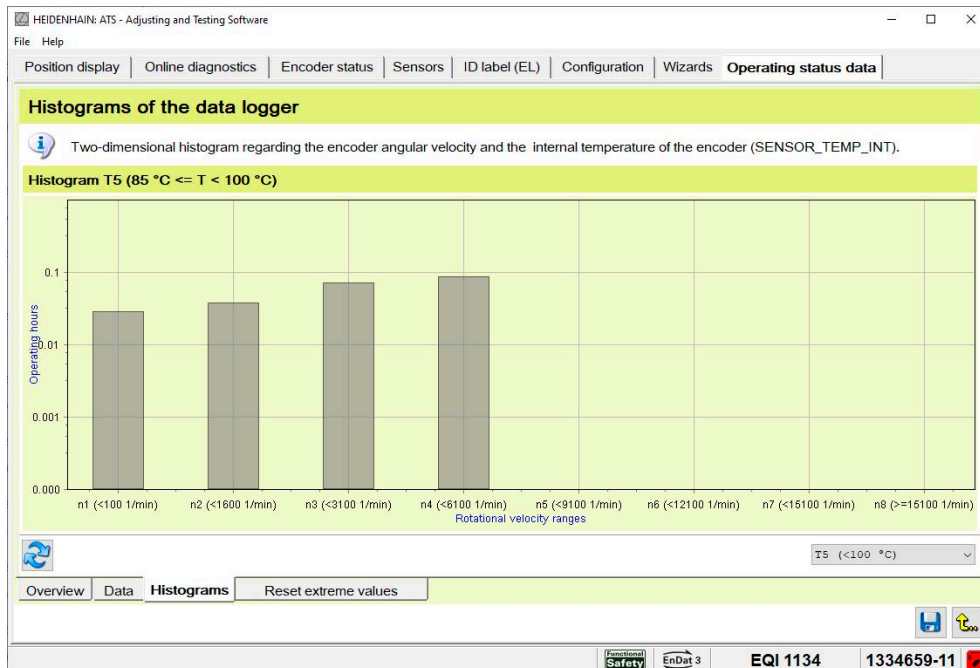

Figure 186: **Histograms of the data logger** view with histogram **T5** (example)

Depiction	Description
X axis	Velocity Unit: depends on the encoder
Y axis	Operating hours

Refreshing data



- ▶ Click **Refresh data**
- ▶ The encoder transmits the current data to the Adjusting and Testing Software
- ▶ The display is refreshed

Resetting extreme values

You can delete the saved **extreme values** from the encoder memory. Afterwards, the encoder starts again to record extreme values.

- ▶ Click the **Reset extreme values** tab to delete the extreme values
- ▶ Click **Reset**
- ▶ Click **OK** to confirm the deletion the extreme values
- > The extreme values are deleted

12.2.9 Miscellaneous functions view

The **Miscellaneous functions** view shows the available additional functions

- ▶ Click the **Miscellaneous** tab to call this view

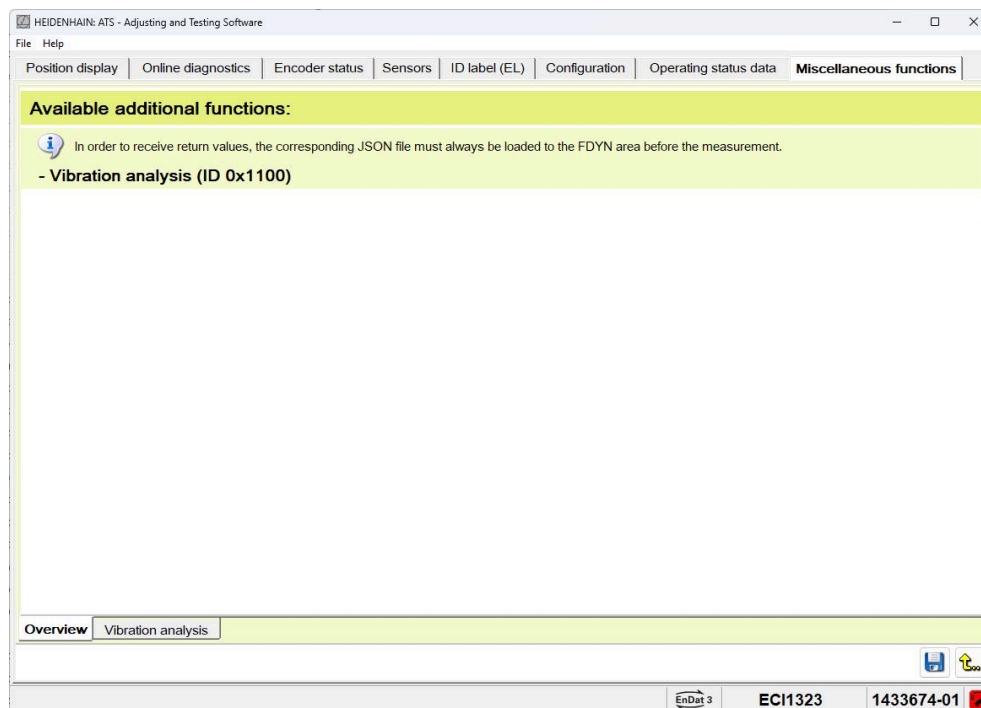

Figure 187: **Miscellaneous functions** view

The **Miscellaneous functions** tab comprises the following views:

- **Overview**
- **Vibration analysis**
- ▶ Click the desired tab in the lower navigation bar to switch between the views

Vibration analysis

In the **Vibration analysis** view you can load a vibration analysis configuration into the encoder. Measurement can be started once the configuration is complete. The appropriate measured values are displayed.

i If no valid configuration is loaded, an error is shown in the Log status display. The error indicates that the transferred data in the corresponding LPF are not valid. This error cannot be cleared.

- ▶ You must load a valid configuration in order to clear the error.

▶ Click the **Vibration analysis** tab to call this view



Figure 188: The **Vibration analysis** view

The left side of the view shows the following information:

- The contents of the fEL and fDYN encoder memory
- The data that were transmitted through the LPF

The right side of the view shows the measured values:

- The blue values show the current measured values
- The red line saves the highest measured values. The red line is reset when measurement is started.

i You can save and print the active diagram.
Further information: "Adjusting, exporting and printing diagrams", Page 48

i To examine a section more closely, you can zoom in on the diagram view.
Further information: "Magnifying the diagram view", Page 48

i For more information on the displayed values, please contact HEIDENHAIN.

Loading a configuration

Before you can start a measurement, you must load a valid configuration into the encoder. The loaded values are shown at left in the view, under fEL or fDYN.

Once the configuration has been loaded, the **Start measurement** operating element becomes active. After each switch to the **Vibration analysis** view, you must reload the configuration or refresh the data.



In order to receive a valid JSON configuration file, please refer to your HEIDENHAIN contact partner or use the contact form under www.heidenhain.com.

You can load the encoder configuration from a JSON file to the **Vibration analysis** view.

- ▶ Click **Load configuration**
- ▶ Select the storage location in the dialog
- ▶ Click **Open**
- > The encoder configuration is loaded from the file

Starting measurement

- ▶ Click **Start measurement**
- > The vibration analysis can be performed.

Saving measured values

If the **Save measured values** function is selected, the measured values will be saved to a .csv file.

The file is stored in a program directory. The program directory depends on the folder you chose when installing the software.

Example:

C:\Program Files (x86)\HEIDENHAIN\ATS36RC\db\tmp\measurements

Resetting a configuration

If the **Reset configuration** function is activated, the `CONFIGRESET` command is executed before writing a new configuration.

- ▶ In order to avoid an undefined status in the encoder, activate the **Reset configuration** function.



- ▶ Click **Refresh data**
- > The encoder transmits the current data of fEL and fDYN



The data can be refreshed only if a valid configuration was already loaded into the encoder.

12.2.10 Saving log data

You can save the test results in a PDF file.

The results of the performed tests are available to be selected as log contents.

The results of a test remain in temporary memory until you disconnect the encoder or repeat the test. You can also add the status messages as log content.

i The status messages are available for selection as log content if you have called the **Encoder status** view once during the test.

- ▶ Click the **Encoder status** tab to call this view



- ▶ Click **Save log**
- > The **Log** dialog is displayed

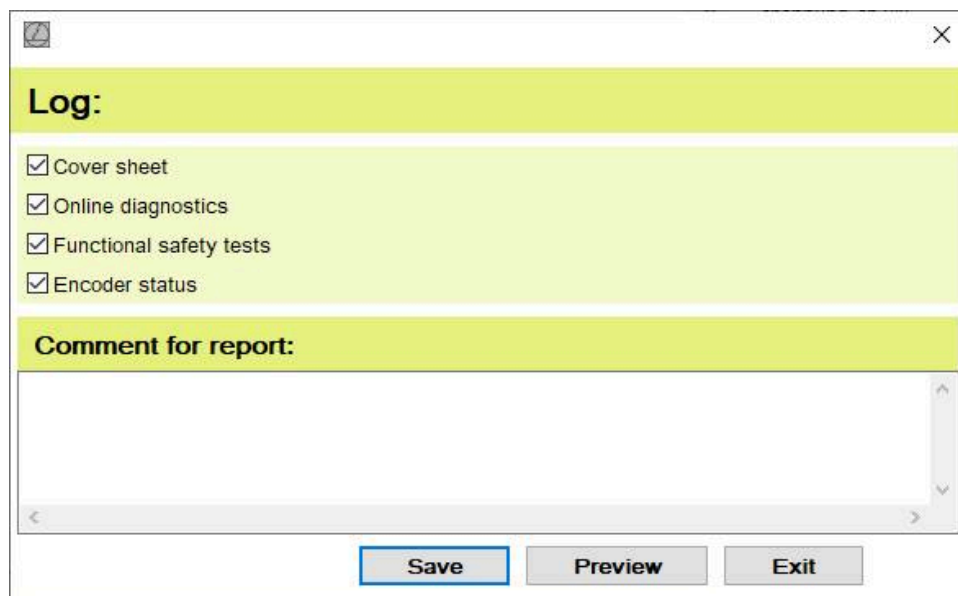

Figure 189: **Log** dialog

- ▶ To select log contents, tick the box in front of the desired content
- ▶ If necessary, enter a comment in the **Comment for report** box
- ▶ Click **Preview** to open the preview of the log
- ▶ Click **Save** to save the log to a PDF file
- ▶ Select the desired storage location in the dialog
- ▶ Enter the file name
- ▶ Click **Save**
- > The file is saved

i In the Adjusting and Testing Software, you can add an individual header and details on the examiner to the logs.

Further information: "Saving log information", Page 57

i To display the PDF contents correctly, the font "Arial Unicode MS" must be installed on the computer.

12.3 Checking the voltage supply

Voltage display function

The **Voltage display** function shows the measured values and the status of the voltage supply. If the encoder and the testing device are connected via a signal adapter, the measured values also include the current consumption of the signal adapter (does not apply to SA 1210 and SA 2380).



► Double-click **Voltage display** in the function menu

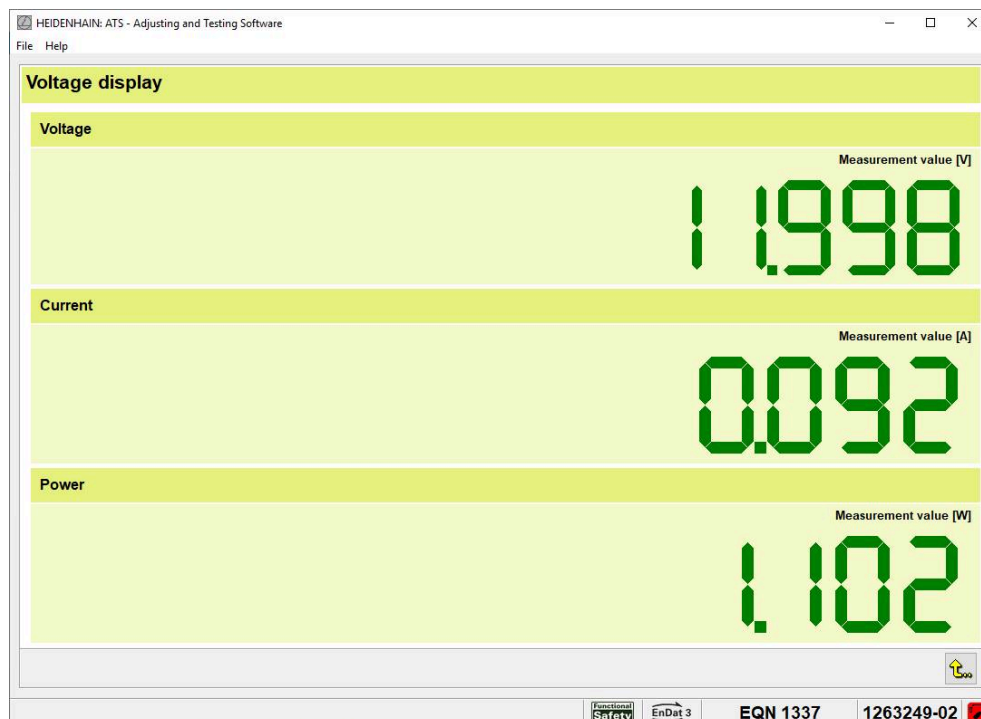



Figure 190: **Voltage display** function

Display	Description
Voltage	Voltage output by the PWM
Current	Current consumption of the encoder and possibly the signal adapter
	<div style="border: 1px solid black; padding: 5px; display: inline-block;">  If the encoder is not consuming any current, the measured value is displayed in red. </div>
Power	Power consumption of the encoder and possibly the signal adapter

12.4 Checking encoders in bus mode

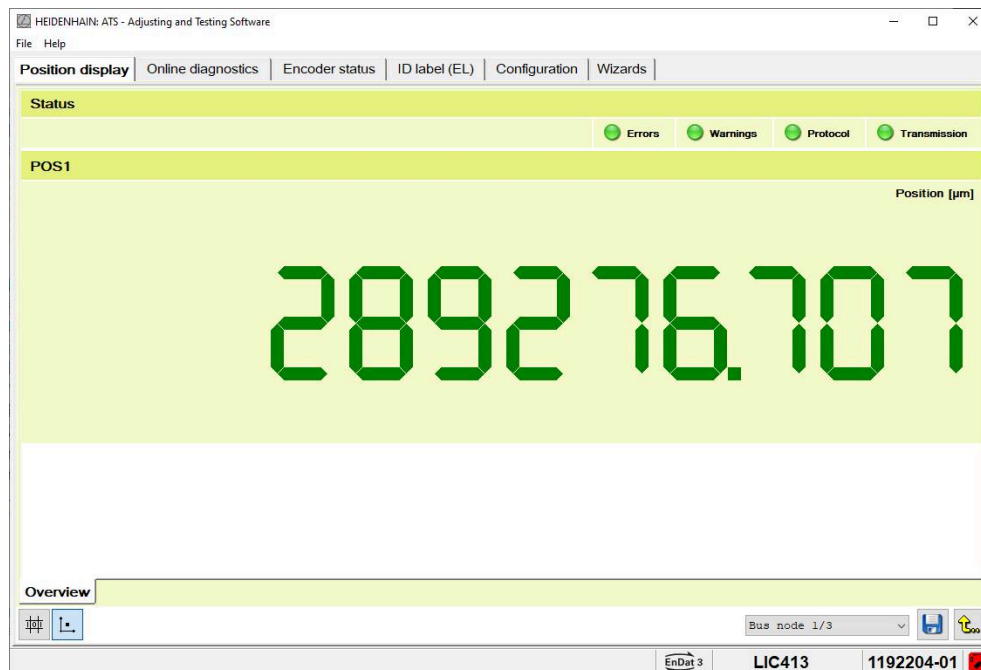

Figure 191: User interface in bus operation

The selection menu in the information bar shows how many participants (bus nodes) are present. All displays and values refer to the selected participant. Thus you can work in the bus mode with all known functions, analogous to the operation with a single encoder.

- ▶ To select another participant, click on the selection menu in the information bar
- > The selection menu opens

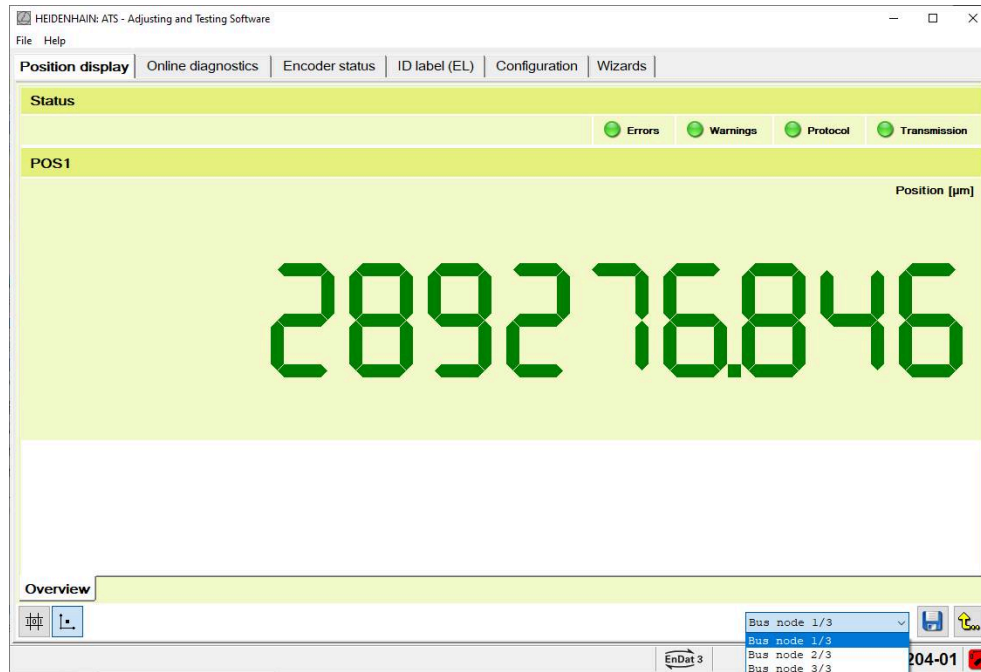

Figure 192: Selection menu with available bus nodes

- ▶ Click the desired bus node
- > The bus node is activated

The selection menu is shown in all functions.

13

**Special interface-
specific functions**

13.1 Overview

This chapter describes special functions of company-specific encoders.

13.2 DRIVE-CLiQ

The Adjusting and Testing Software supports the following interfaces.

■ DRIVE-CLiQ interface

i DRIVE-CLiQ is a registered trademark of Siemens AG.

i The configuration of the encoder by the PWM differs from the configuration for real operation at the machine tool. This concerns, for example, the time of transmission. During real operation errors may occur that do not occur during encoder diagnostics with the PWM. In addition to the test with the encoder diagnostic set, an additional test during actual operation is therefore recommended.

Position display

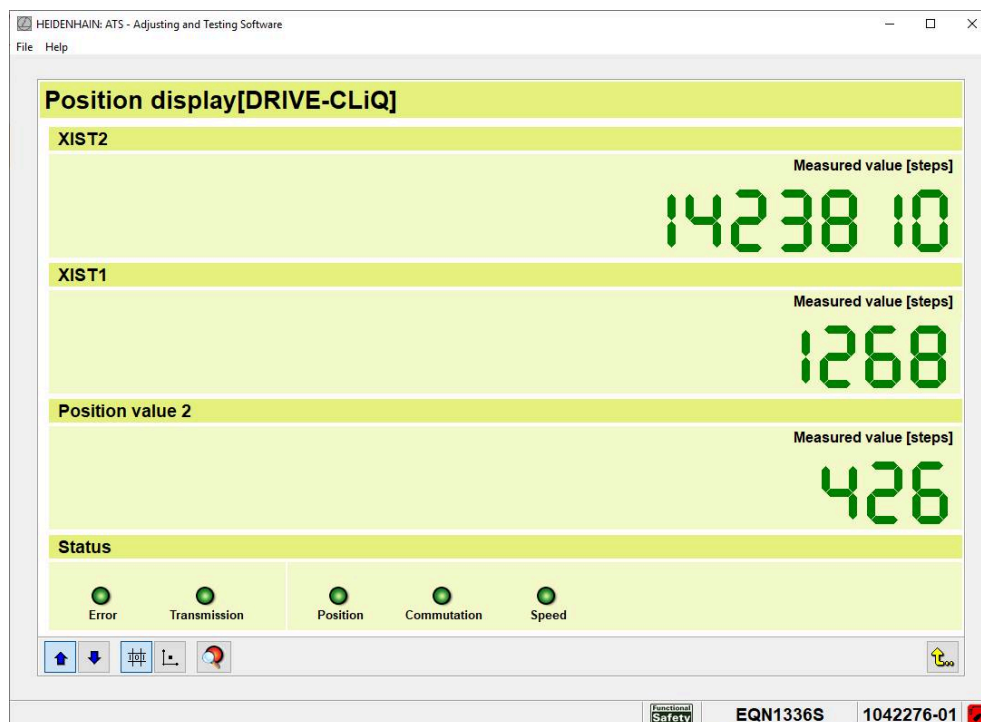



Figure 193: **Position display** function

Display	Description
XIST2	Absolute encoder position Unit: Increments
XIST1	Incremental value of the encoder position Unit: Increments
Position value 2	For encoders that support functional safety: Redundant position value
Error	Status display of encoder errors <ul style="list-style-type: none"> ■ Green: No status message available ■ Red: Status message available
Transmission	Status display of data transfer between encoder and testing device <ul style="list-style-type: none"> ■ Green: No status message available ■ Red: Status message available
Position	Position status display <ul style="list-style-type: none"> ■ Green: No status message available ■ Red: Status message available
Commutation	Status display of commutation <ul style="list-style-type: none"> ■ Green: No status message available ■ Red: Status message available
Speed	Status display of speed <ul style="list-style-type: none"> ■ Green: No status message available ■ Red: Status message available

Supplementary screen of the position display

The Position display function features a supplementary screen with further information. To switch between the screens, the following operating elements are available in the control bar:

Icon	Function
	Switch to standard view Displays the standard view
	Switch to supplementary view Displays supplementary information

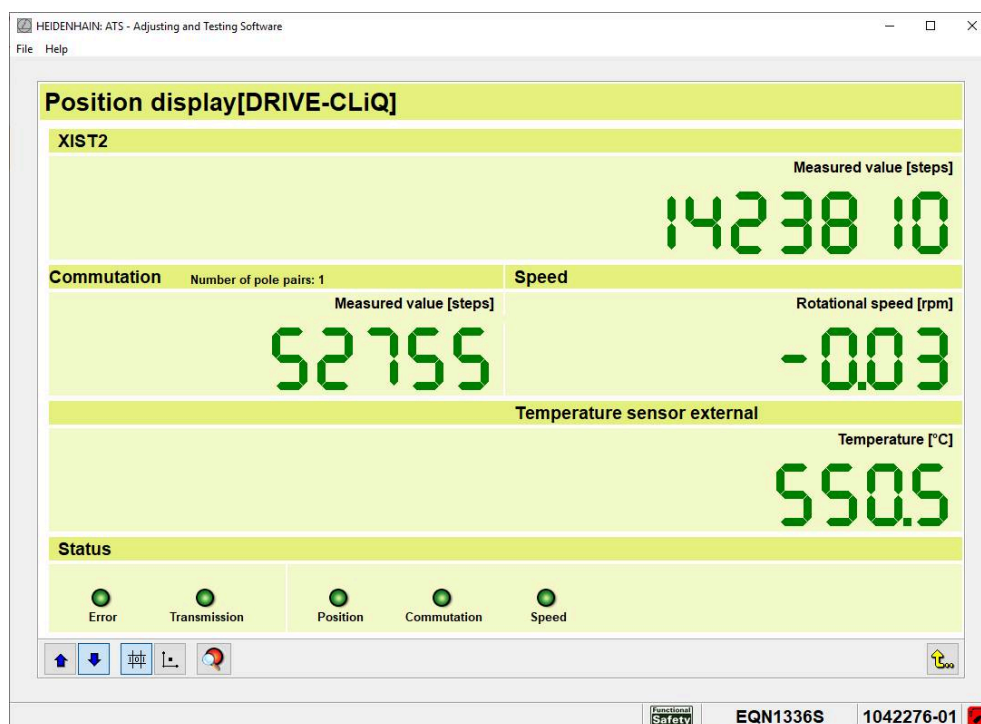

Figure 194: Supplementary screen of the **Position display** function

Display	Description
Commutation	Commutation angle with reference to the pole pair width: <ul style="list-style-type: none"> ■ The pole pair width for linear encoders is 25 mm; i.e. 0° to 360° are displayed within 25 mm ■ The pole pair width for rotary or angle encoders is 1; i.e. 0° to 360° are displayed within one revolution Unit: Increments
Speed	Current traversing speed or shaft speed Unit: Meters per second or revolutions per minute (depending on the encoder)
External temperature sensor	Current temperature measured by the external temperature sensor, e.g. winding temperature



Extreme temperature values indicate that the temperature sensor is not connected, a contact is open or a cable has broken.

Encoder status screen

The **Encoder status** screen provides detailed information on errors.



- ▶ Click **Status information** in the control bar to call the **Encoder status** screen

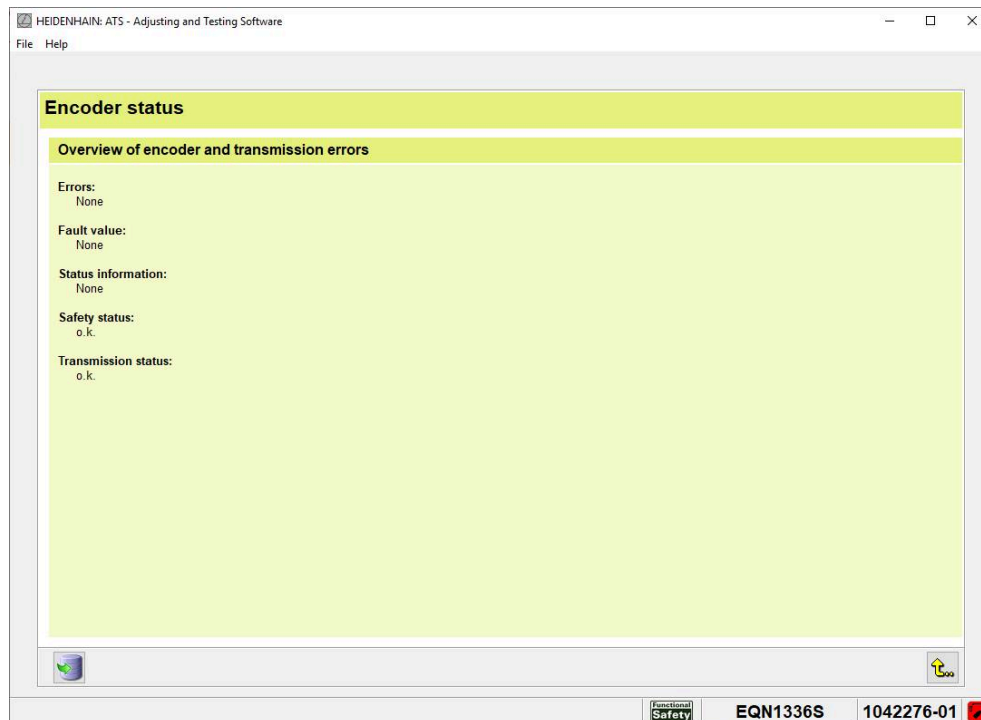

Figure 195: **Encoder status** screen

Display	Description
Errors	Information about malfunctions of the encoder, e.g.: <ul style="list-style-type: none"> ■ Encoder error ■ Software error ■ Kernel error ■ Safety error
Fault value	Detailed information on errors (if available for the respective error number)
Status information	Messages about the encoder status
Safety status	Messages about safety-relevant functions
Transmission status	Messages about communication errors, (e.g., CRC error or packet loss)

Backing up the encoder configuration

You can load the encoder configuration from the encoder and save it as a ZIP file on the computer for backup or diagnostic purposes.



The ZIP file is protected by a password and can only be decoded by the den HEIDENHAIN Service.



- ▶ Double-click **Save encoder memory** in the function menu
- > The **Save encoder memory** view is displayed.

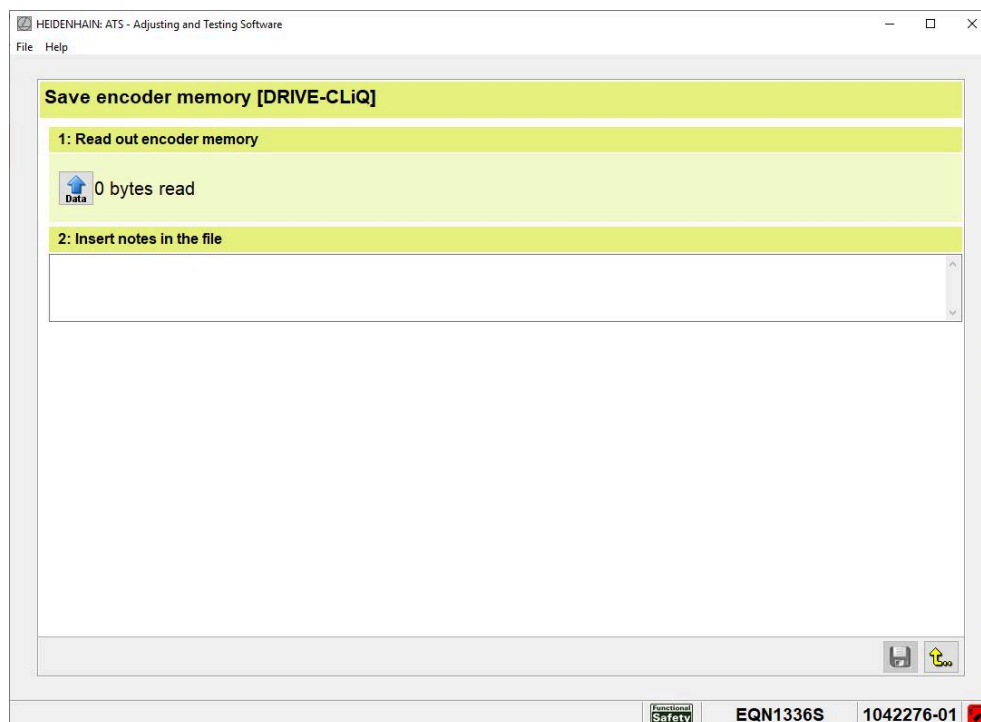

Figure 196: **Save encoder memory** screen



- ▶ Click **Read out encoder memory** in the control bar
- > The Adjusting and Testing Software displays the read-out status.
- > When the data has been read out, the **Save file** operating element is displayed as active.



- ▶ Enter comments in the **Notes** field, if required
- ▶ Click **Save file**
- ▶ Select the desired storage location in the dialog
- ▶ Enter the file name
- ▶ Click **Save**
- > The file is saved.

Encoder parameter display function

Encoders with **DRIVE-CLiQ interface** feature the additional function **Encoder parameter display**. The **Encoder parameter display** provides information required for putting the encoder into service with Siemens controls. If the encoder is connected via an external signal converter, information on the signal converter is displayed, too.



- ▶ To call this function, double-click **Encoder parameter display** in the function menu
- > The Adjusting and Testing Software displays information about the connected encoder.

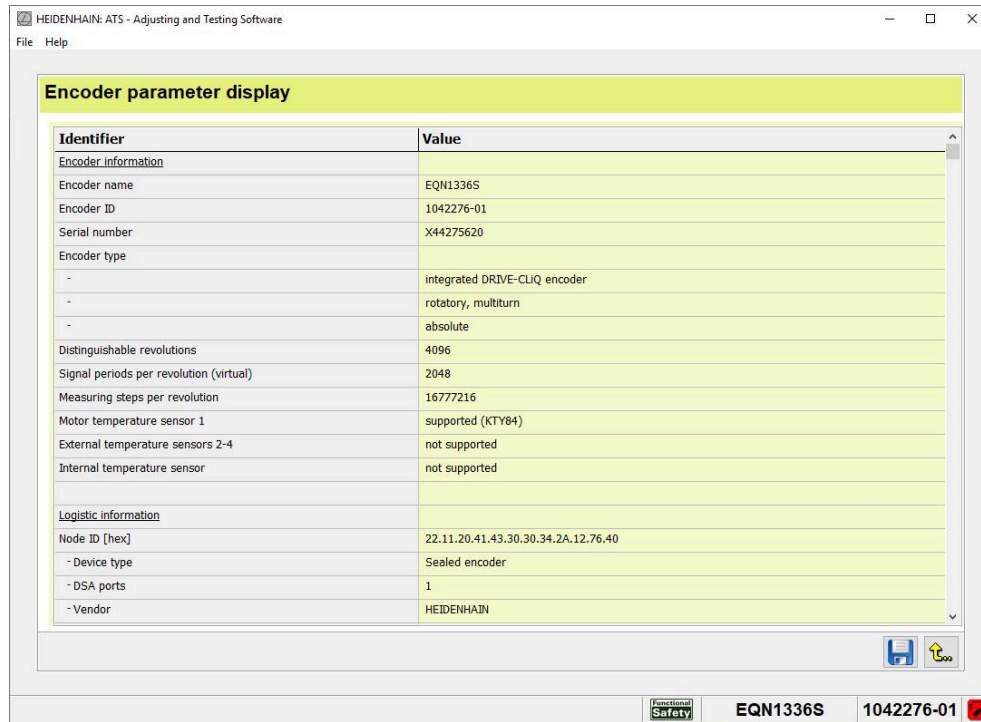

Figure 197: Encoder parameter display function

Logistic information section

Display	Description
Node ID	Terminal identification within the DRIVE-CLiQ drive system; worldwide unique number
Device type	To specify the encoder type, e.g. integrated encoder, sealed encoder, converter from EnDat 2.2 to DRIVE-CLiQ
DSA ports	For HEIDENHAIN encoders, the value "1" is entered here (single-ended module)
Vendor	Manufacturer code
Version	Version number of the encoder
Serial number	Serial number of the encoder
Index	Always assigned 0
MLFB	Ordering designation of the encoder
FW version	Firmware version and functionality of the device
ROM version	This information is relevant for R&D
EEPROM version	Total of the encoder memory contents; this information is relevant for R&D

Functional safety section

The plausibility of the values to each other is tested in the "Functional-Safety encoder check". Thus, the values displayed here are for information only. For position comparison, the types "binary" and "non-binary" are relevant. This refers to the ratio of XACT1 and Pos2. Linear encoders are usually "non-binary". Rotational encoders are usually "binary".

Display	Description
Supported forced dynamic sampling	Supported error message for the validation test
Error bit F1	Test cases 1 to 16
Error bit F2	Test cases 1 to 16
Comparison algorithm	Algorithm for position value comparison
Pos2 configuration	Characteristics of position value 2
Pos2 shift value	Resolution of position value 2, relevant bits
Pos2 number bits fin res	Resolution characteristics of position value 2
Relevant Pos2 bits	Number of bits of position 2 that are used in the safety comparison algorithm; value only not equal to zero for encoders with binary position comparison
Offset Pos1-Pos2	Offset between position 1 (XACT1) and position 2 in the resolution of position 2
nsrPos1	Not safety-relevant measuring steps of position 1 (XACT1); generally not supported on encoders with binary position comparison
nsrPos2	Not safety-relevant measuring steps of position 2 (XACT2); generally not supported on encoders with binary position comparison

Display	Description
srM	Safety-relevant measuring steps that are taken into account for position comparison; generally not supported on encoders with binary position comparison
Offset2	Offset between position 1 (XACT1) and position 2 in the resolution of position 1 (XACT1); generally not supported on encoders with binary position comparison

Further information section

Display	Description
Encoder datum shift	Display of the datum shift, if saved in the encoder
Size of OEM memory in bytes	Size of the memory range reserved for information by the OEM
TIME2LINK_OK MAX in ms	Maximum time after which the encoder can communicate via DRIVE-CLiQ If no value is displayed, the switch-on time tSOT applies (stated in the brochure).
T_MAX_ACT_VAL in µs	Earliest transmission time of a DRIVE-CLiQ packet after position latch

i The values **Signal periods per revolution (virtual)** and **Grid division (virtual)** are derived from the measuring step and correspond to the parameter settings in the DRIVE-CLiQ encoder configuration. The values are not related to the physical properties (signal period) of the encoder.

Functional-safety encoder check function

The **Functional-safety encoder check** is also available for encoders without functional safety and allows for examining basic parameters and settings. If the Functional-safety encoder check is not available, this indicates a malfunction of the encoder.

i If the functional-safety encoder check results in errors, the encoder does not comply with the functional safety specifications. Repairs may be carried out only by the HEIDENHAIN Service department.

i After installing and exchanging functional safety components, repeat the acceptance test according to the specifications of the machine tool builder.



- ▶ To call this function, double-click **Functional-safety encoder check** in the function menu
- The dialog **Manual entry of measuring length** may be displayed (depending on the encoder).
- ▶ Enter the measuring length in millimeters
- ▶ Confirm the entry with **Accept**
- The software wizard shows a list of the supported diagnostic functions.

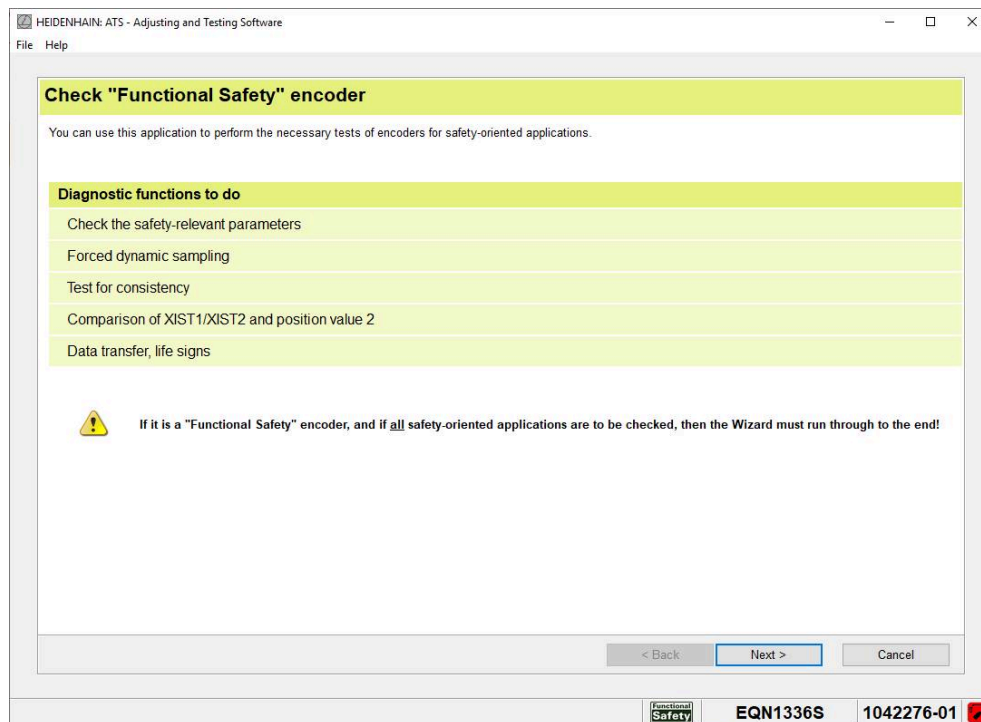

Figure 198: List of the diagnostic functions for encoders with functional safety

Depiction	Description
Check the safety-relevant parameters	Check of safety-relevant memory areas
Forced dynamic sampling	Check of the error generators in the encoder and of the consistency of the data stored in the encoder The tests performed depend on the supported error messages (depending on the encoder).
Test for consistency	Test for consistency of position value 2
Comparison of XIST1/XIST2 and position value 2	Position-comparison triple: Comparison of Pos1, Pos2 and the parameter p12020 in the encoder configuration
Data transfer, life signs	Check of data transfer and life signs of the encoder hardware and software

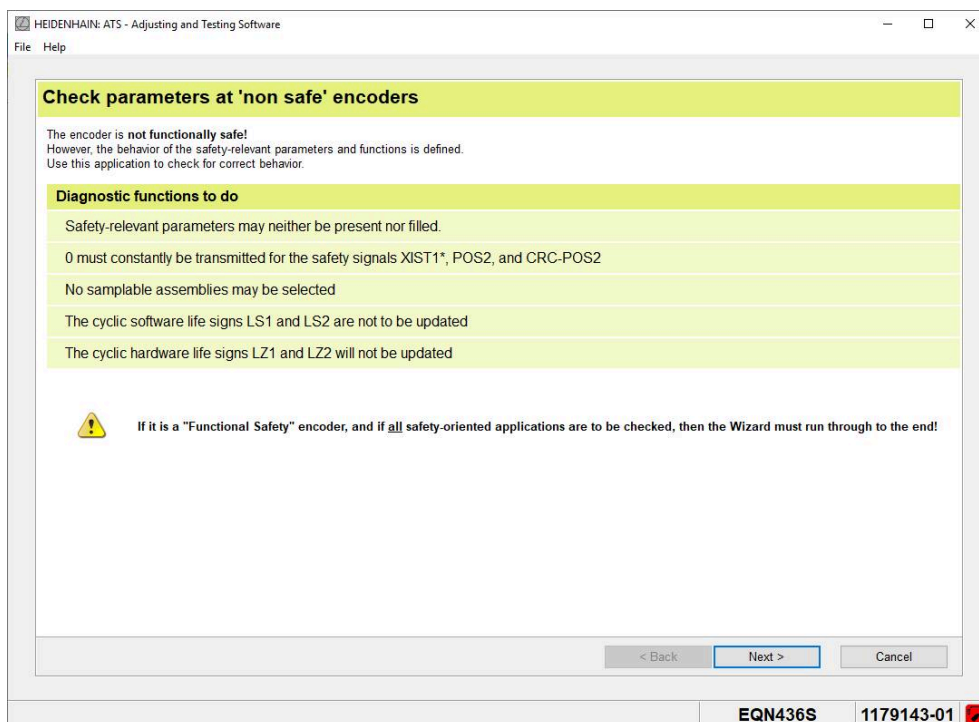

Figure 199: Overview of the diagnostic functions of encoders without functional safety

- ▶ Click **Next** to inspect the safety-relevant memory areas
- The Adjusting and Testing Software checks whether the safety-relevant parameters are available and filled with values.
- The software wizard shows the result of the examination.

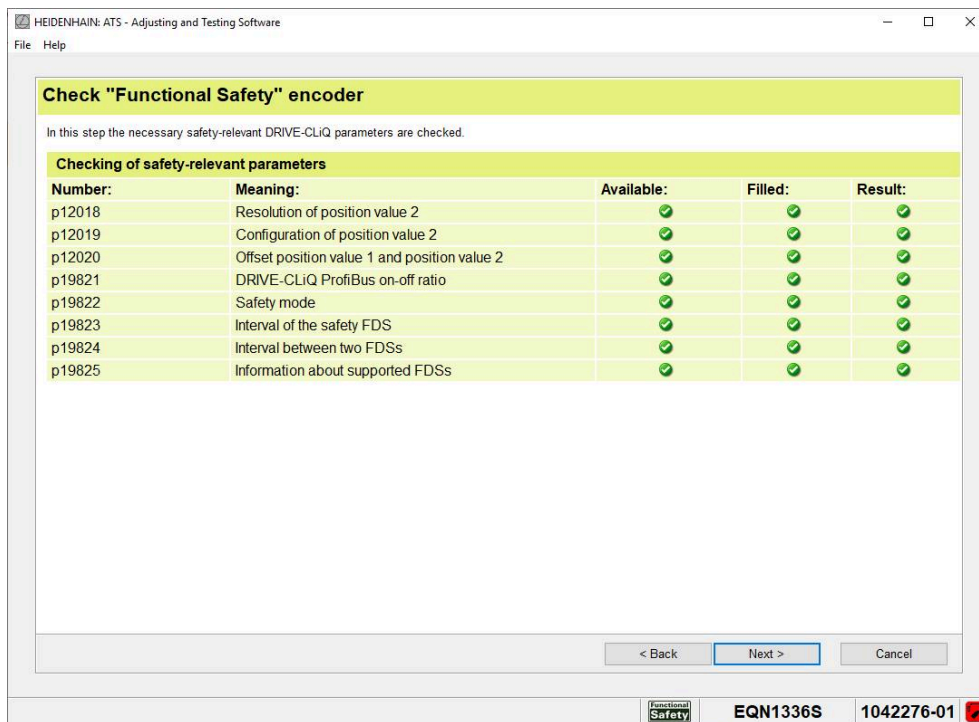





Figure 200: Test results for safety-relevant parameters

The following symbols are used to show the test result:

Icon	Description
	Test successful for parameters that must be available and filled with values
	Test successful for parameters that do not have to be available or filled with values
	Test failed

- ▶ Click **Next** to run forced dynamic sampling
- The Adjusting and Testing Software executes forced dynamic sampling.
- The software wizard shows the result of forced dynamic sampling.

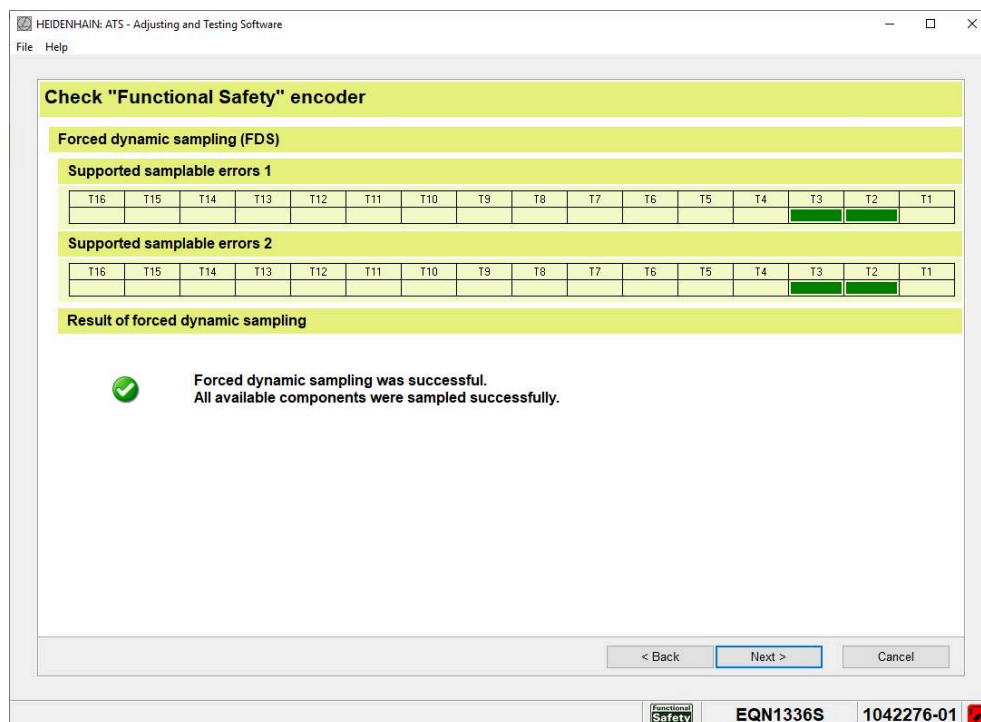

Figure 201: Result of forced dynamic sampling

- ▶ Click **Next** to continue
- The Adjusting and Testing Software displays information on the test for consistency and the comparison of position values.

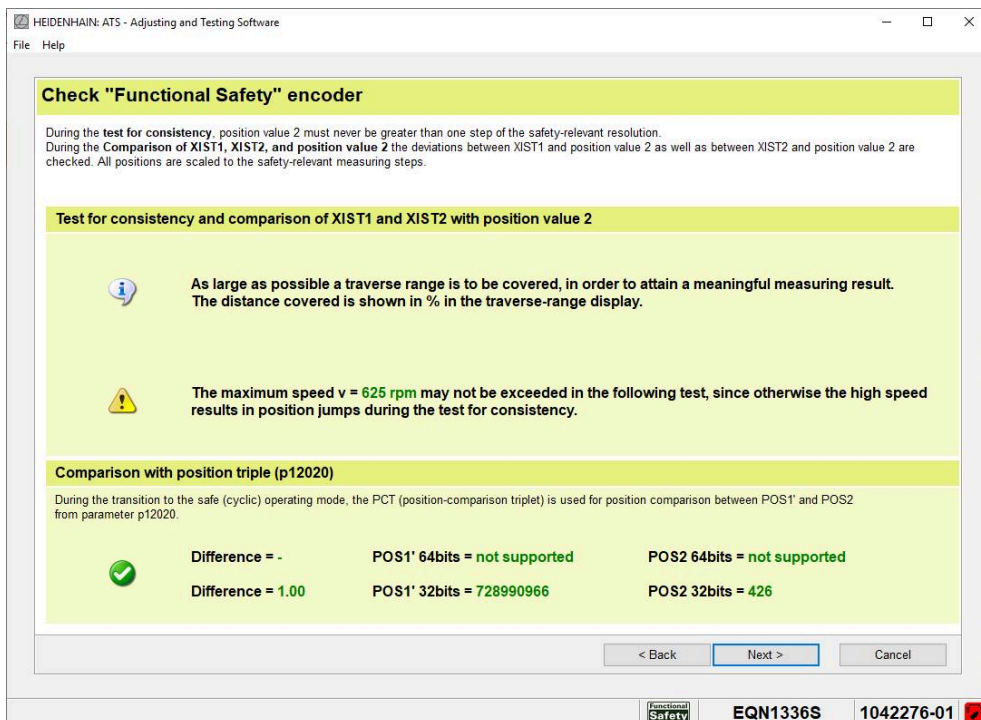



Figure 202: Result of the test for consistency

- ▶ Click **Next** to run the test for consistency and the comparison of position values
- ▶ Traverse the entire measuring range
- ▶ The software wizard shows the result of the tests

 For linear encoders, only the 64-bit view is shown.

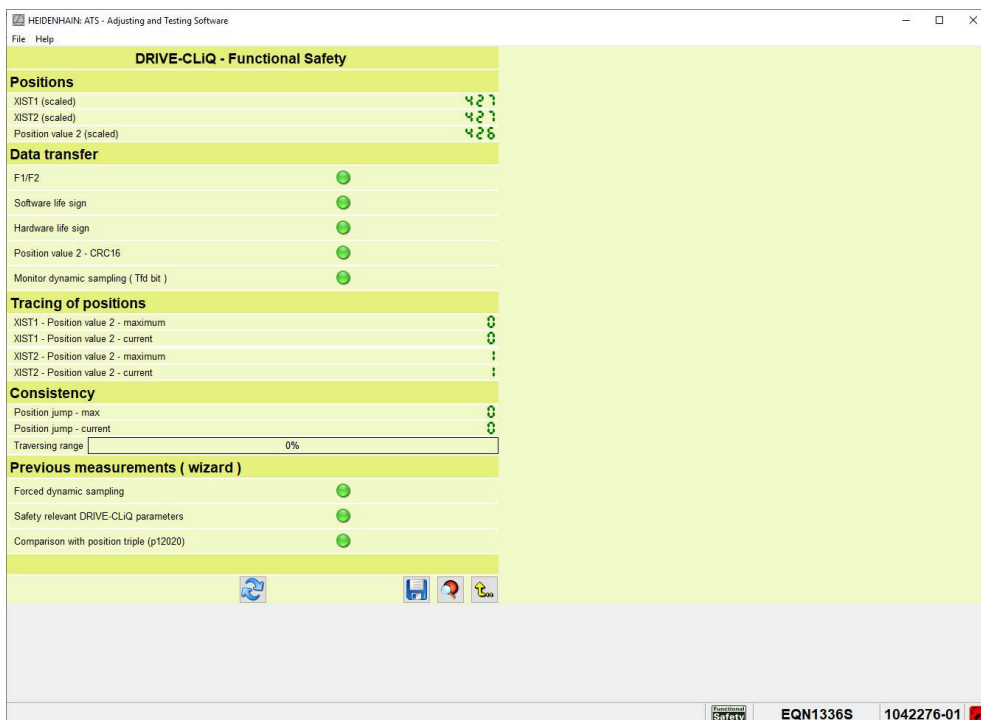



Figure 203: Results overview of the functional-safety encoder check

 Red values or status displays indicate a malfunction of the encoder.

Positions section

Display	Description
XIST1 (scaled)	Scaled position value XIST1 The resolution used for the test complies with the functional safety specifications
XIST2 (scaled)	Scaled position value XIST2 The resolution used for the test complies with the functional safety specifications
Position value 2 (scaled)	Scaled position value 2 The resolution used for the test complies with the functional safety specifications

Data transfer section

Display	Description
F1/F2	Position error bits (encoder-internal)
Software life sign	Life sign generated by the encoder software
Hardware life sign	Life sign generated by the encoder hardware
Position value 2 – CRC16	The position 2 created by the scanning ASIC of the encoder is verified by means of an additional CRC in the encoder
Monitor dynamic sampling (Tfd bit)	Monitoring bit indicating that an error occurred during forced dynamic sampling "Tfd = test failed"

Tracing of positions section

Display	Description
XIST1 – Position value 2 – maximum	Maximum value of the comparison of incremental position and redundant absolute position
XIST1 – Position value 2 – current	Current value of the comparison of incremental position and redundant absolute position
XIST2 – Position value 2 – maximum	Maximum value of the comparison of absolute position and redundant absolute position
XIST2 – Position value 2 – current	Current value of the comparison of absolute position and redundant absolute position

 With linear encoders, the 16-bit limitation of position value 2 may lead to an error message because the Adjusting and Testing Software does not perform the required modulo calculation.

Consistency section

Display	Description
Position jump – max	Maximum position jump during the entire test
Position jump – current	Current position jump
Traversing range	Measuring distance traversed during the test Unit: Percent

Previous measurements (wizard) section

Display	Description
Forced dynamic sampling	Result of forced dynamic sampling
Safety-relevant DRIVE-CLiQ parameters	Test results for safety-relevant DRIVE-CLiQ parameters
Comparison with position triple (p12020)	Result of position comparison

Repeating test for consistency and comparison of position values

- ▶ Click **Delete measured values** in the control bar to repeat the test for consistency and the comparison of position values
- The measured values and status displays are reset.
- ▶ Traverse the entire measuring range
- The software wizard shows the result of the tests

Online diagnostics function

Since encoders with DRIVE-CLiQ interface do not support monitoring operation, the software wizard automatically selects the operating mode **Encoder diagnostics**.

13.3 Fanuc

The Adjusting and Testing Software supports the following interfaces:

- **Fanuc Serial Interface α**
- **Fanuc Serial Interface ci**

Position display

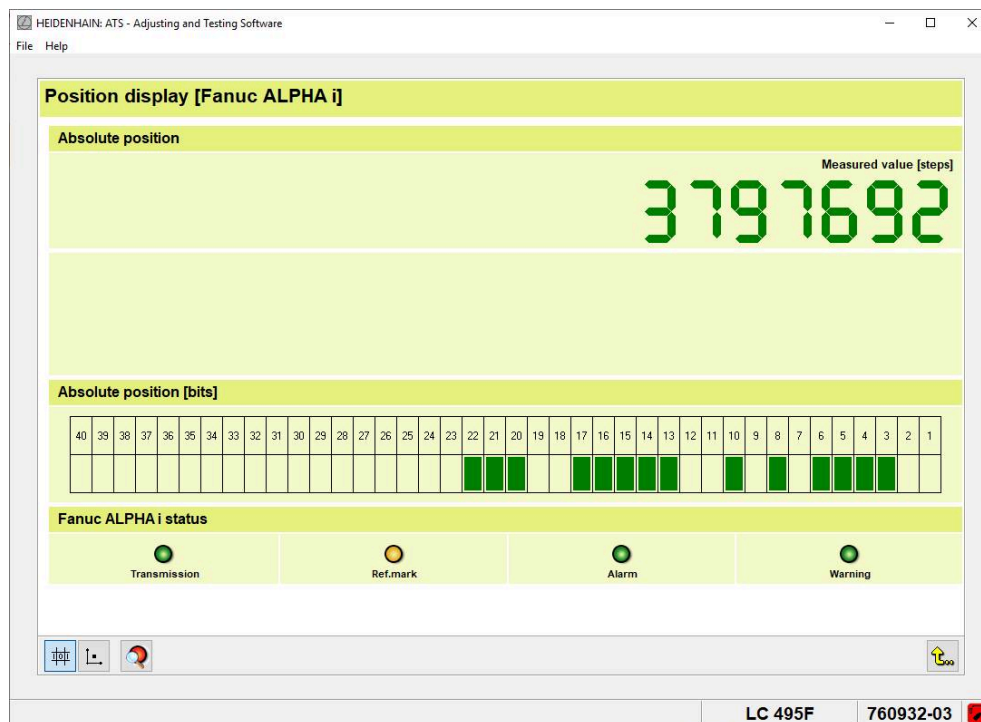

Figure 204: **Position display** function

Display	Description
Absolute position	Absolute encoder position Unit: Increments
Absolute position [bits]	Binary display of the absolute encoder position The number of bits depends on the encoder. Bit 1 = LSB (Least Significant Bit)
Transmission	Status display of data transfer between encoder and testing device <ul style="list-style-type: none"> ■ Green: No status message available ■ Red: Status message available
Ref.mark	Status display of reference mark detection Absolute encoders with serial interfaces: <ul style="list-style-type: none"> ■ Gray: No reference mark was detected ■ Yellow: Reference mark detected or absolute encoder Incremental encoders with external signal converter: <ul style="list-style-type: none"> ■ Gray: No reference mark was detected ■ Yellow: Reference run finished, absolute position value available

Display	Description
Alarm	Status display of encoder alarms <ul style="list-style-type: none"> ■ Green: No status message available ■ Red: Status message available
Warning	Status display of encoder warnings <ul style="list-style-type: none"> ■ Green: No status message available ■ Red: Status message available

Resetting status messages

The following steps are necessary in order to reset status messages:



- ▶ Double-click **Disconnect encoder** in the function menu
- ▶ Switch off the PWM

Fanuc ALPHA i ID data display function

Encoders with **Fanuc Serial Interface αi** feature the additional function **Fanuc ALPHA i ID data display**.



- ▶ To call this function, double-click **Fanuc ALPHA i ID data display** in the function menu
- ▶ The Adjusting and Testing Software displays information on the connected encoder

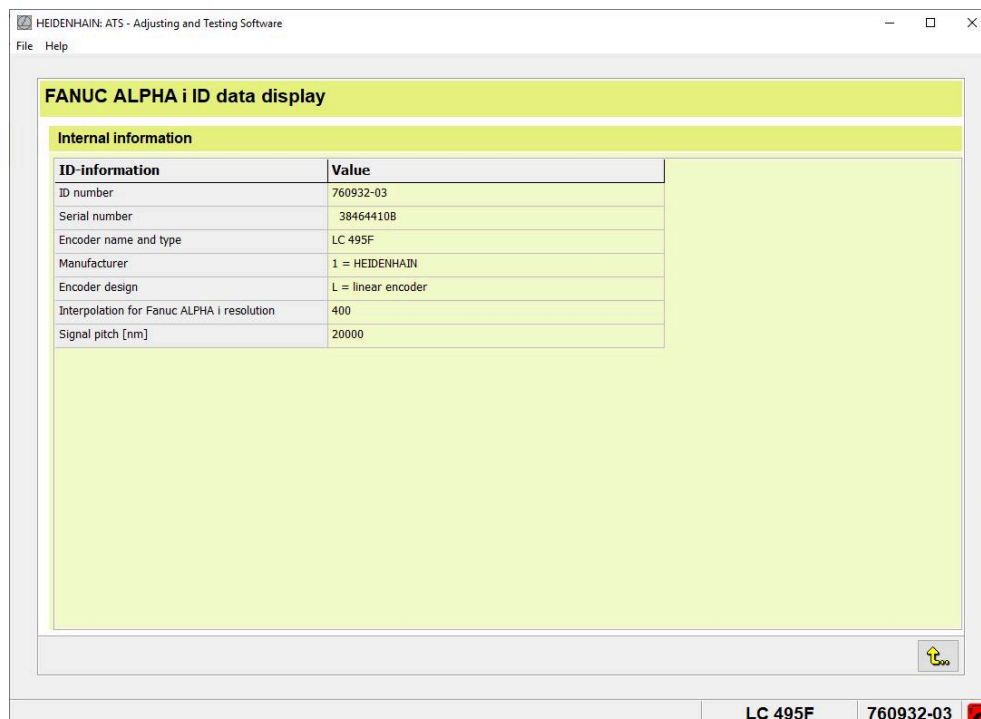

Figure 205: **Fanuc ALPHA i ID data display** function

Online diagnostics function in the monitoring mode

On encoders with ordering designation "Fanuc 05", you can switch between ALPHAI mode and ALPHA mode to adapt the evaluation of the Adjusting and Testing Software to the parameterization of the subsequent electronics. For this purpose, the control bar contains the following operating elements:

Icon	Function
α	Switch to ALPHA mode Evaluates the communication between subsequent electronics and encoder in the ALPHA mode
αi	Switch to ALPHAI mode Evaluates the communication between subsequent electronics and encoder in the ALPHAI mode

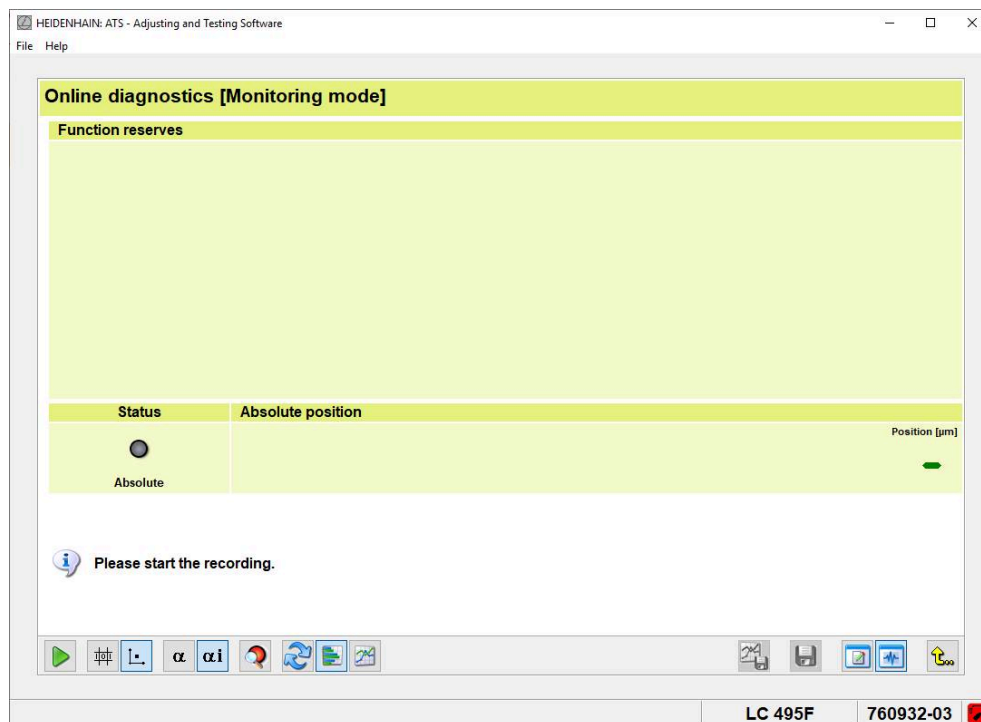

Figure 206: **Online diagnostics** function in the monitoring mode

13.4 Mitsubishi

The Adjusting and Testing Software supports the following interface:

- **Mitsubishi High Speed Interface**

Position display function

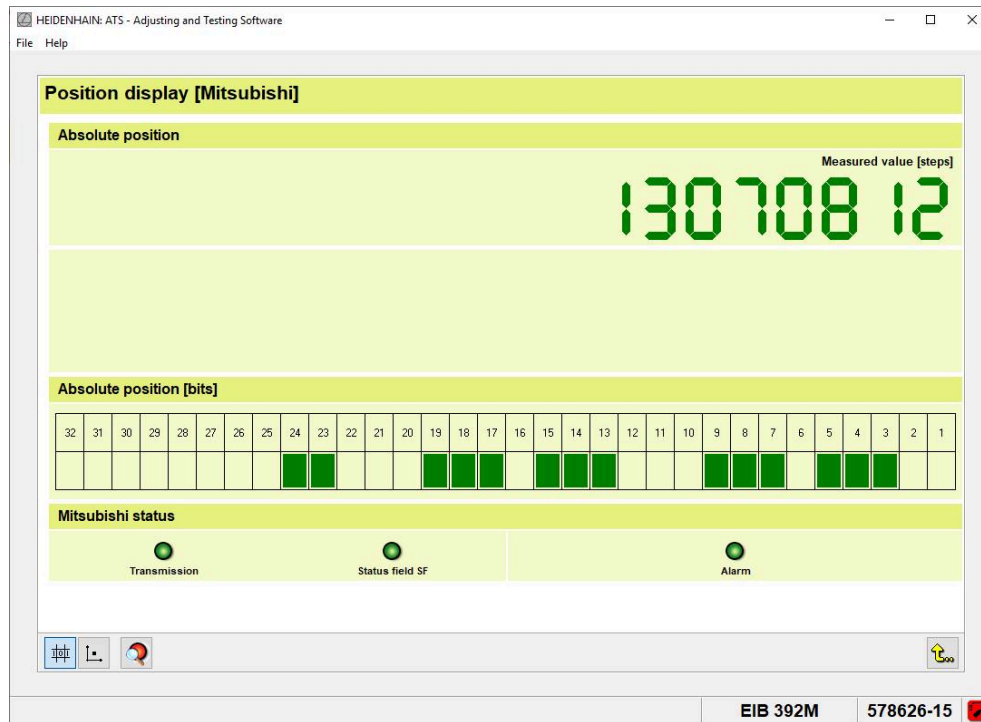

Figure 207: **Position display** function

Display	Description
Absolute position	Absolute encoder position Unit: Increments
Absolute position [bits]	Binary display of the absolute encoder position; the number of bits depends on the encoder Bit 1 = LSB (Least Significant Bit)
Transmission	Status display of data transfer between encoder and testing device <ul style="list-style-type: none"> ■ Green: No status message available ■ Red: Status message available
Status field SF	Display of the status information output by the encoder; with incremental encoders including the status of reference mark detection <ul style="list-style-type: none"> ■ Green: No status message available ■ Red: Status message available
Alarm	Status display of encoder alarms <ul style="list-style-type: none"> ■ Green: No status message available ■ Red: Status message available

13.5 Panasonic

The Adjusting and Testing Software supports the following interfaces:

- **Panasonic Serial Interface**

Position display

The **Position display** function displays the following information:

Display	Description
Absolute position	Absolute encoder position Unit: Increments
Absolute position [bits]	Binary display of the absolute encoder position; the number of bits depends on the encoder Bit 1 = LSB (Least Significant Bit)
Transmission	Status display of data transfer between encoder and testing device <ul style="list-style-type: none"> ■ Green: No status message available ■ Red: Status message available
Alarm	Status display of encoder alarms <ul style="list-style-type: none"> ■ Green: No status message available ■ Red: Status message available

13.6 Yaskawa

The Adjusting and Testing Software supports the following interfaces:

- **Yaskawa Serial Interface**

Position display

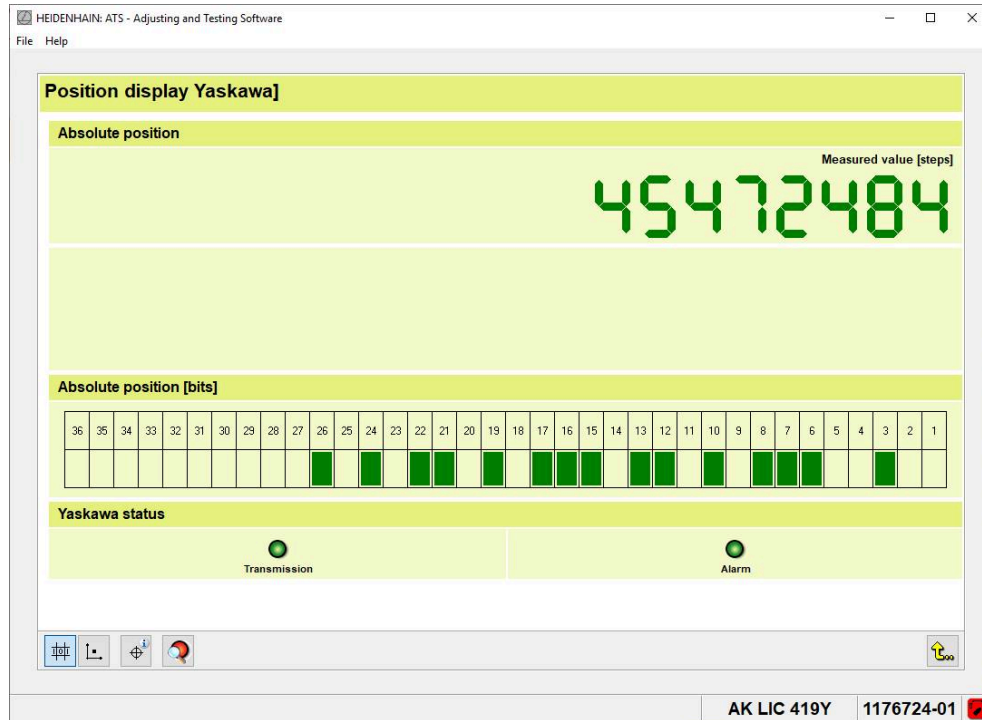

Figure 208: **Position display** function

Display	Description
Absolute position	Absolute encoder position Unit: Increments
Absolute position [bits]	Binary display of the absolute encoder position The number of bits depends on the encoder. Bit 1 = LSB (Least Significant Bit)
Transmission	Status display of data transfer between encoder and testing device <ul style="list-style-type: none"> ■ Green: No status message available ■ Red: Status message available
Alarm	Status display of encoder alarms <ul style="list-style-type: none"> ■ Green: No status message available ■ Red: Status message available

Yaskawa parameter display function

Encoders with **Yaskawa Serial Interface** feature the additional function **Yaskawa Encoder Parameters**.



- ▶ To call this function, double-click **Yaskawa parameter display** in the function menu
- The Adjusting and Testing Software displays information about the connected encoder.

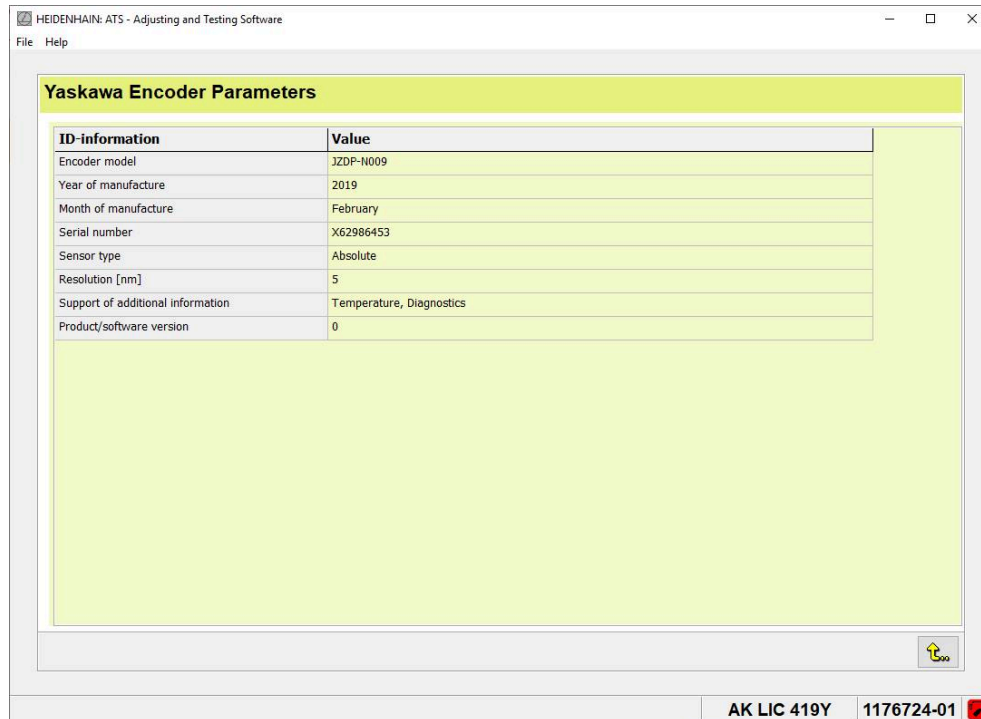

Figure 209: **Yaskawa parameter display** function

13.7 SSI

Position display

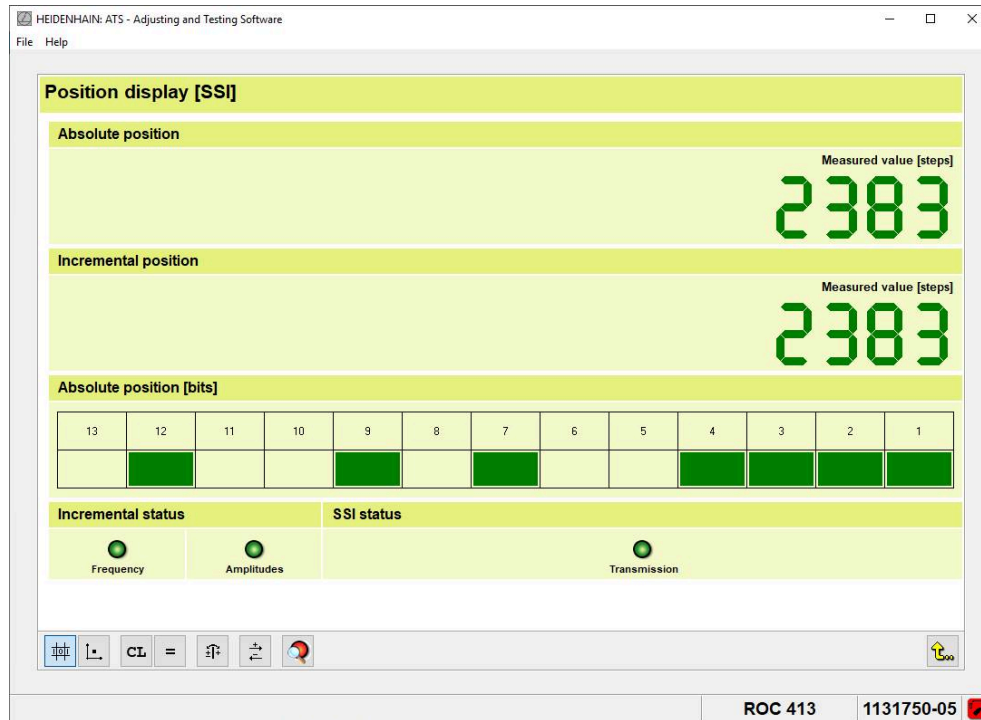

Figure 210: **Position display** function

Display	Description
Absolute position	Absolute encoder position Unit: Increments
Incremental position	Count value of incremental counter Unit: Increments
Absolute position [bits]	Binary display of the absolute encoder position The number of bits depends on the encoder. Bit 1 = LSB (Least Significant Bit)
Frequency	Status display of signal frequency <ul style="list-style-type: none"> Green: Signal frequency is within tolerance Red: Signal frequency is outside the tolerance range
Amplitudes	Status display of signal amplitudes <ul style="list-style-type: none"> Green: The signal amplitudes are within the tolerance range Red: The signal amplitudes exceed at least one tolerance limit
Transmission	Status display of data transfer between encoder and testing device <ul style="list-style-type: none"> Green: No status message available Red: Status message available

Absolute to incremental deviation function

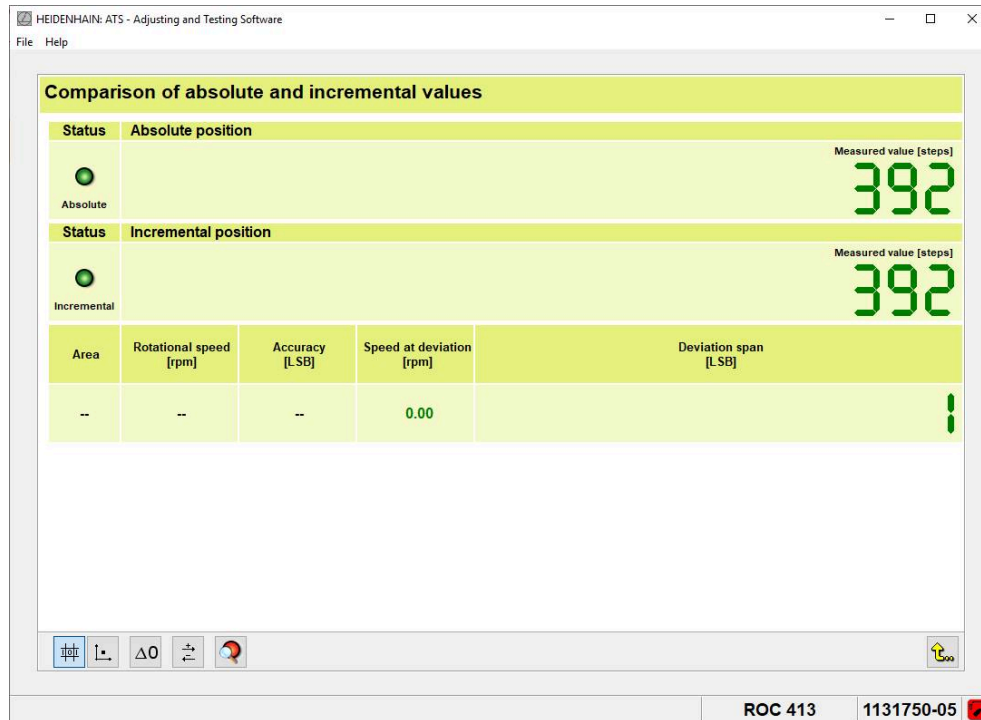

Figure 211: Ascertainment of the **absolute to incremental deviation**

No velocity ranges or tolerance values are available when determining the **absolute to incremental deviation**. The deviation span is considered too high and displayed in red color, if the difference between the absolute position and the incremental position exceeds the absolute number of measuring steps per revolution.

13.8 Indramat

Connecting the encoder

Encoders with Indramat interface must be identified by entering the encoder ID in order that the test functions are available in the Adjusting and Testing Software.

14

**Optional
special functions
(software options)**

14.1 Overview

This chapter describes the special functions of the Adjusting and Testing Software that can be enabled by entering a license key.

Further information: "Enabling software options", Page 53

14.2 Advanced DRIVE-CLiQ functions (software option 14)

The following functions are available upon activation of the software option:

- Setting the datum shift on encoders with interfaces of the DRIVE CLiQ type

Precondition: The encoder supports datum shift.



The procedure is the same as for encoders with EnDat interface.

Further information: "Setting datum shift", Page 205

- Expanded parameter display

Further information: "Expanded parameter display function", Page 364

14.2.1 Expanded parameter display function

With the **Expanded parameter display** function, you can search for a parameter number or save a parameter list.

When querying the parameters, you can choose between cyclic mode and acyclic mode. In cyclic mode, communication takes place in a defined time grid that is monitored. Master and encoder exchange both cyclic data, e.g. positions, and asynchronous data, e.g. parameters. In acyclic mode, the master controls the parameter request. Communication does not take place according to fixed time grid.



- ▶ To call this function, double-click **Expanded parameter display** in the function menu
- The Adjusting and Testing Software shows the **Acyclic parameter display** view.

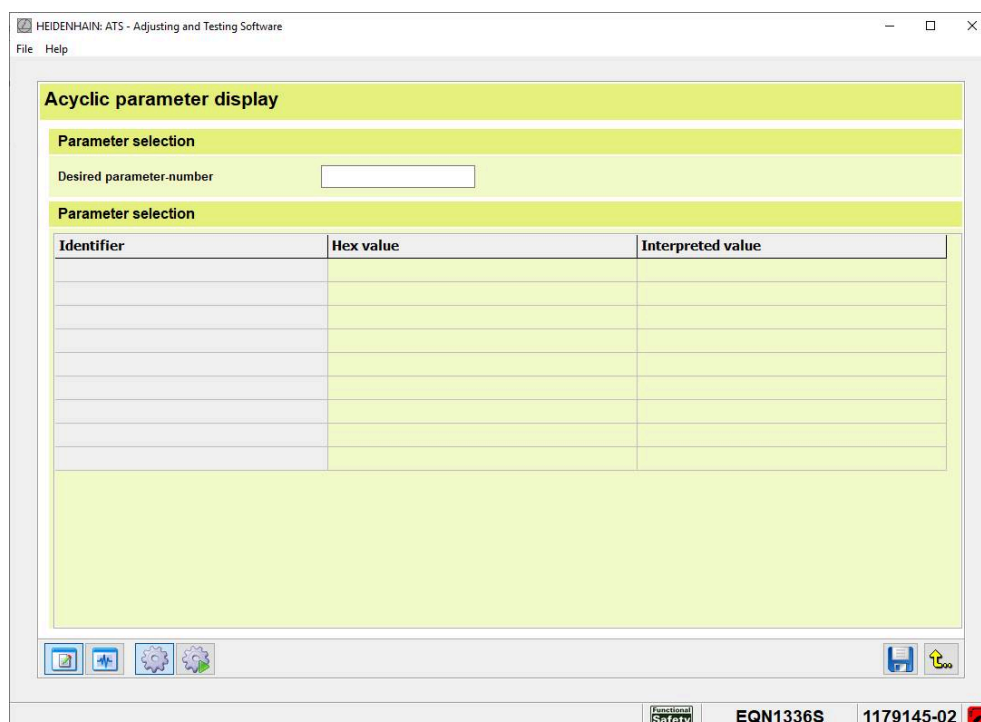







Figure 212: **Acyclic parameter display** view of the **Extended parameter display** function

Operating elements

Icon	Function
	Enter parameters individually An individual parameter is displayed
	Show all parameters All parameters are displayed
	Query parameters in acyclic mode Activates acyclic parameter request
	Query parameters in cyclic mode Activates cyclic parameter request
	Save file Opens the dialog for saving the displayed parameters to a TXT file

14.2.2 Entering parameters individually

Precondition: The encoder supports the parameter.





- ▶ To display an individual parameter, click **Enter parameter individually** in the control bar
- ▶ Enter the desired parameter number
- ▶ The Adjusting and Testing Software displays the contents of the parameter.

14.2.3 Showing all parameters



- ▶ Click **Display all parameters** in the control bar
- ▶ The Adjusting and Testing Software shows a list of all parameters.

 The query may take several seconds.

 You can save the parameter list in a file.
Further information: "Saving the parameter list to a file", Page 366

14.2.4 Switching to cyclic parameter display



- ▶ To switch to the cyclic query mode, click **Query parameters in cyclic mode** in the control bar

14.2.5 Switching to acyclic parameter display



- ▶ To switch to the acyclic query mode, click **Query parameters in acyclic mode** in the control bar

14.2.6 Saving the parameter list to a file

You can save the displayed parameters in a TXT file.



- ▶ Click **Save file** in the control bar
- ▶ Select the desired storage location in the dialog
- ▶ Enter the desired file name
- ▶ Click **Save**
- > The file is saved.

14.3 Adjusting the tolerance limits of incremental signals (software option 20)

When you activate this software option you can adjust the tolerance limits the Adjusting and Testing Software uses for the current check of the incremental signals.

You can save the changed limit values in an INI file. You can load the limit values from this INI file back into the Adjusting and Testing Software and use them for later tolerance checks.



When you exit the **Incremental signal** function, the Adjusting and Testing Software resets the tolerance limits to default.

Further information: "Units and tolerances", Page 36

14.3.1 Customizing view

In the **Customizing** view you can edit the **minimum** and **maximum** tolerance limits. The **Default** column shows the standard value saved in the encoder database.

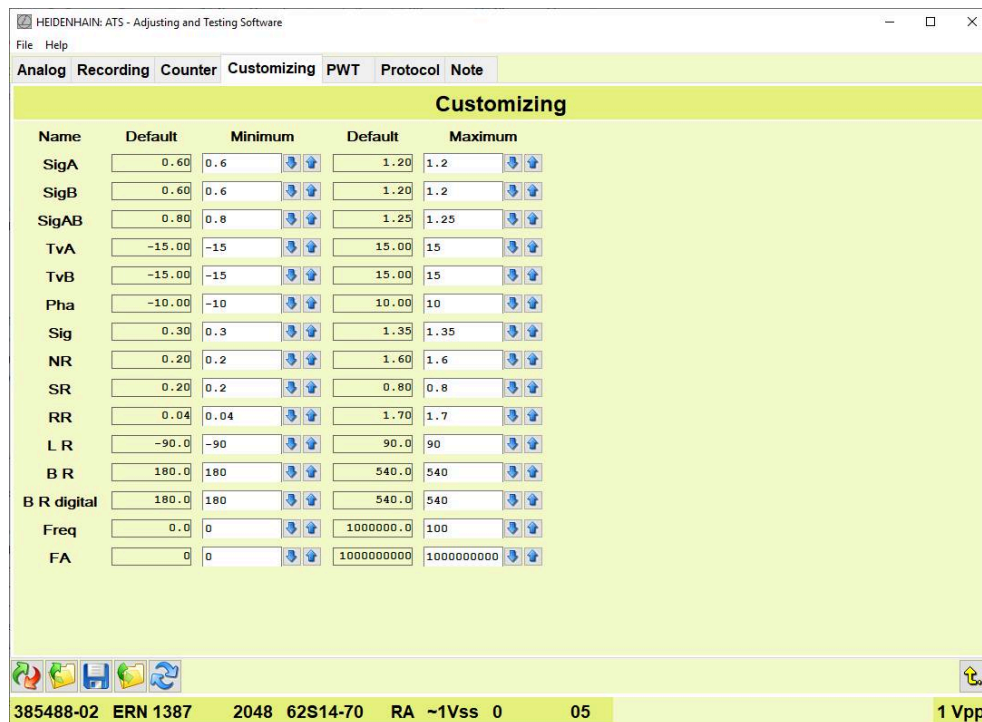









Figure 213: Customizing view of the Incremental signal function

Possible modifications

Name	Description
SigA	Signal amplitude Unit: volts
SigB	Signal amplitude Unit: volts
SigAB	Signal amplitude ratio
TvA	On-off ratio Unit: degrees
TvB	On-off ratio Unit: degrees
Pha	Phase angle Unit: degrees
Sig	Current signal monitoring
NR	Reference – usable component Unit: volts
SR	Reference – trigger threshold Unit: volts
RR	Reference – quiescent value Unit: volts

Name	Description
L R	Reference position Unit: degrees
B R	Reference width Unit: degrees
B R digital	Reference width Unit: degrees
Freq	Frequency Unit: kHz
FA	Minimum edge separation Unit: Microseconds

Operating elements

Icon	Function
	Reduce value Reduces the value in the input field
	Increase value Increases the value in the input field
	Load the changes Adopts the changed values as new tolerance limits
	Open file Opens the dialog for reloading saved tolerance limits from an INI file
	Save file Opens the dialog for saving the tolerance limits to an INI file, or saves the tolerance limits under the displayed file name
	Save file as Opens the dialog for saving the tolerance limits to an INI file
	Load default values Loads the standard tolerance limits into the input fields

14.3.2 Customizing tolerance limits



- ▶ Double-click **Incremental signal** in the function menu
- ▶ Click the **Customizing** tab to switch to the **Customizing** view

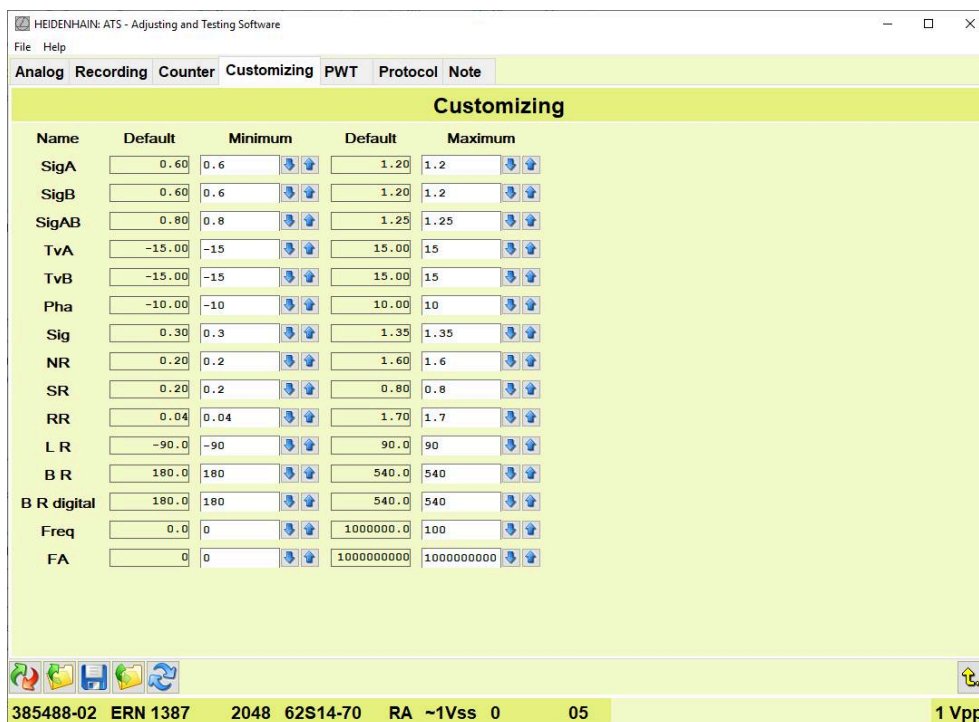

Figure 214: Customizing view of the Incremental signal function

- ▶ To change a tolerance limit, enter the desired value in the input field
- ▶ Confirm with **Enter**
- or
- ▶ Click on **Decrease value** or **Increase value** next to the input field until the desired value is displayed
- ▶ Press and hold the operating element to change values more quickly



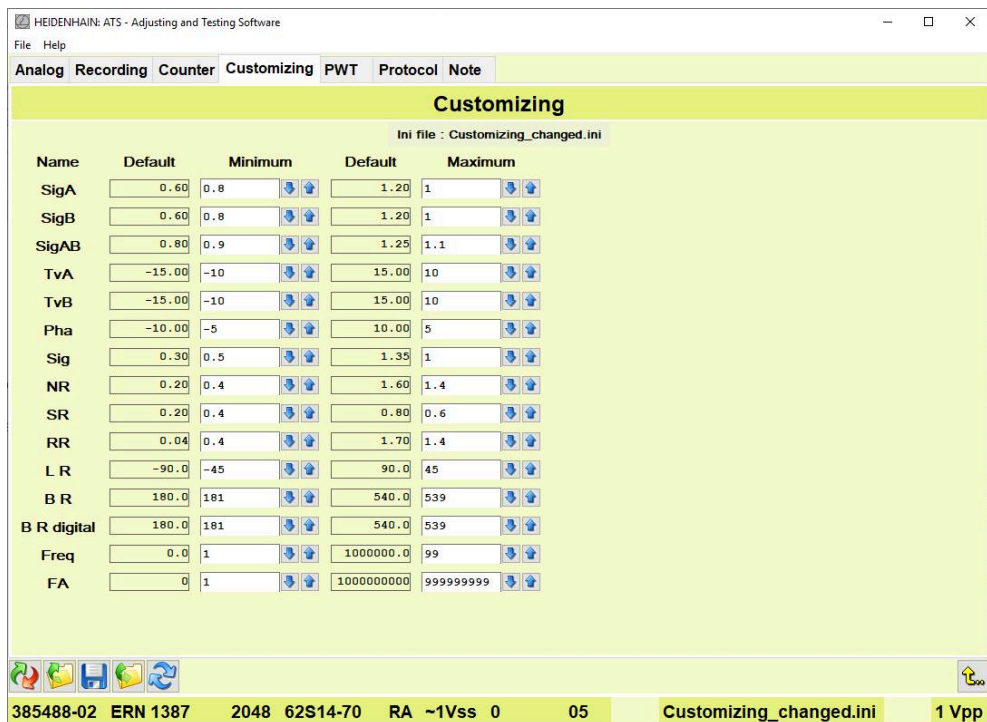

Figure 215: **Customizing** view with changed tolerance limits



- ▶ To use the displayed tolerance limits for the current examination, click **Apply changes** in the control bar
- The Adjusting and Testing Software applies the new tolerance limits.

The effect of the changes is as follows:

- X/Y graph: The positions of the gray circles correspond to the changed tolerance limits
- Bar graphs: The red marks correspond to the changed tolerance limits
- **Sig Mon** status displays: Signal monitoring uses the changed tolerance limits

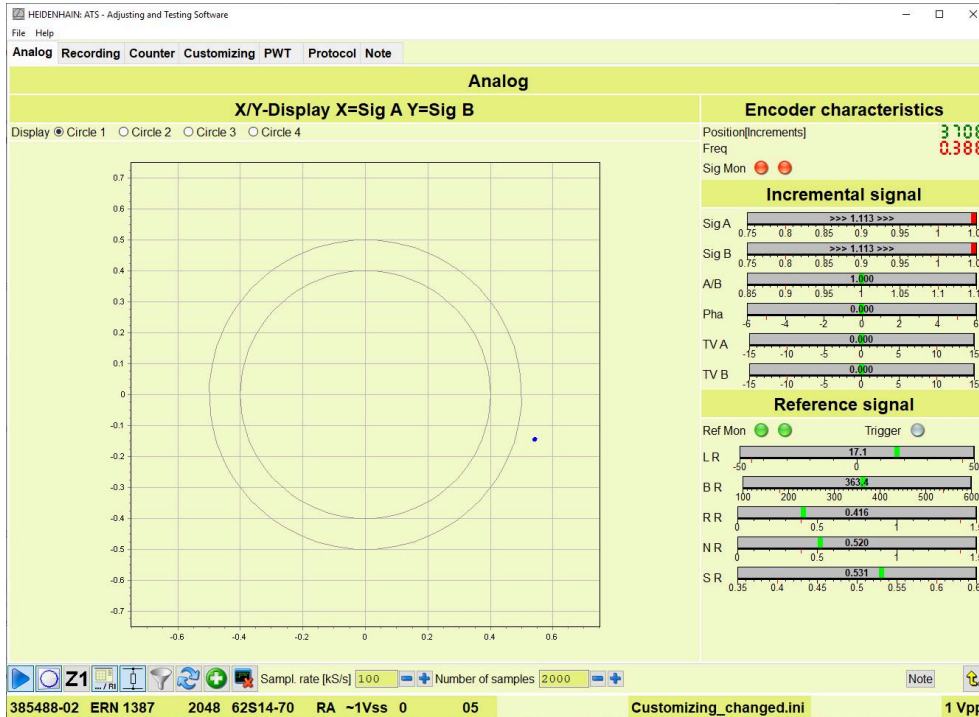

Figure 216: Analog view with changed tolerance limits

14.3.3 Saving tolerance limits to a file

You can save the changed tolerance values in an INI file. You can create a new file for this purpose or overwrite an existing file.

Saving tolerance limits to a new file



- ▶ Click **Save as** in the control bar
- ▶ Select the desired storage location in the dialog
- ▶ Enter the desired file name
- ▶ Click **Save**
- The file is saved.
- The Adjusting and Testing Software displays the file name.

Saving tolerance limits to an existing file

If you have saved tolerance limits in a file or loaded them from a file, you can overwrite the tolerance values of the displayed file.

- ▶ Load the desired file, if necessary
- ▶ **Further information:** "Loading tolerance limits from a file", Page 372
- The Adjusting and Testing Software displays the file name.
- ▶ Customize tolerance limits
- ▶ Click **Save file** in the control bar
- The file is overwritten.



14.3.4 Loading tolerance limits from a file

Precondition: The values are available in an INI file.

To load tolerance limits from a file to the **Customizing** screen, proceed as follows:



- ▶ Click **Open file** in the control bar
- ▶ Select the storage location in the dialog
- ▶ Click **Open**
- > Adjusting and Testing Software loads the limit values into the input fields.



- ▶ To use the tolerance limits in the Adjusting and Testing Software, click **Apply changes** in the control bar
- > The Adjusting and Testing Software applies the new tolerance limits.

14.3.5 Resetting tolerance limits to default

When you exit the **Incremental signal** function, the Adjusting and Testing Software will automatically reset the tolerance limits to default.

If you would like to continue in the **Incremental signal** function and reset the tolerance limits to default, proceed as follows:



- ▶ Click **Load defaults** in the control bar
- ▶ The Adjusting and Testing Software writes the default values to the input fields



- ▶ To use the tolerance limits in the Adjusting and Testing Software, click **Apply changes** in the control bar
- > The Adjusting and Testing Software applies the new tolerance limits.

14.4 Setting the datum shift on encoders with company-specific interfaces (software option 24)

If you activate this software option, you can also set a datum shift for encoders with the following interfaces:

- Fanuc
- Mitsubishi
- Panasonic
- Yaskawa

Precondition: The encoder supports datum shift.



The procedure is the same as for encoders with EnDat interface.

Further information: "Setting datum shift", Page 205

14.5 Setting the datum shift on encoders with EnDat interfaces (software option 29)

If you activate this software option, you can also set a datum shift for encoders with the following interfaces:

- EnDat

Precondition: The encoder supports datum shifting.

Further information: "Setting datum shift", Page 205

15

What to do if ...

15.1 Overview

This chapter describes the causes of faults or malfunctions and the appropriate corrective actions.

15.2 Troubleshooting

Fault	Cause of fault	Correction of fault
The Adjusting and Testing Software does not recognize the PWM	The PWM is not connected correctly, or supply voltage is missing	<ul style="list-style-type: none"> ▶ Check whether the PWM is connected as specified in the operating instructions Further information: "Opening documentation", Page 47 ▶ Check the power cable ▶ Check whether the PWM is switched on ▶ Check whether the PWM has been selected as testing device Further information: "Selecting the PWM as testing device", Page 55
	PWM 20, PWM 21: Device drivers are missing	Further information: "PWM 20, PWM 21: Installing drivers", Page 40
	PWM 3000: Incorrect network settings	Further information: "PWM 3000 network settings", Page 40
	Device function faulty	▶ Contact a HEIDENHAIN service agency
The Adjusting and Testing Software does not recognize the encoder, or functions cannot be performed	Excessive voltage drop on the lines connecting the testing device and the encoder	<ul style="list-style-type: none"> ▶ Activate voltage readjustment by the PWM Further information: "Connection in the Encoder Diagnostics operating mode", Page 63
	The cables are not suitable	<ul style="list-style-type: none"> ▶ Check whether the prescribed cables are used (see User's Manual "Cables and Connection Technology PWM 20 and PWM 21 (IK 215) Testing Package") Further information: "Opening documentation", Page 47

Fault	Cause of fault	Correction of fault
The encoder ID cannot be found in the encoder database	The encoder has not yet been added to the encoder database	<ul style="list-style-type: none"> ▶ Update the encoder database <p>Further information: "Updating software and encoder database", Page 40</p> <ul style="list-style-type: none"> ▶ Connect the encoder manually <p>Further information: "Connecting the encoder", Page 59</p> <ul style="list-style-type: none"> ▶ Contact the HEIDENHAIN Service and ask for the ATS code <p>Further information: "Connecting with ATS code or communication code", Page 87</p>
	The ID is not correct	<p>Check whether correct ID was entered, e.g.:</p> <ul style="list-style-type: none"> ■ With exposed or multi-section encoders: the ID of the scanning head ■ With sealed linear encoders: the ID of the scale housing <p>Further information: "Connecting the encoder", Page 59</p>
No signal is shown in the monitoring mode	The encoder is not supplied with power	<ul style="list-style-type: none"> ■ Check whether the subsequent electronics is switched on
The Adjusting and Testing Software does not display any information on incremental signals	The encoder does not output incremental signals	<ul style="list-style-type: none"> ▶ Check if the encoder provides incremental signals <p>Further information: "Measuring methods and interfaces", Page 24</p>
Computer performance problems occur while the Adjusting and Testing Software is running	Processing power is insufficient or limited, e.g. because the PWM is connected to the computer via keyboard, USB hub or docking station	<ul style="list-style-type: none"> ▶ Check the system requirements <p>Further information: "System requirements", Page 38</p> <ul style="list-style-type: none"> ▶ Connect the PWM directly to the computer

16 Index

A

Absolute to incremental deviation.... 215
 Activation code
 Change..... 311
 Set..... 311
 Additional sensors..... 272
 ATS code..... 86
 Authentication..... 314

B

Bus operation
 Address assignment..... 300
 Checking encoders..... 335
 Connect..... 66
 Connect bus chain..... 32

C

Cables and Connection Technology
 Documentation..... 47
 Checking functional safety..... 317
 Checking Limit switching signals.... 132,
 183
 Checking the reference signal... 163
 Check of commutation signals.. 112
 Check of reference signal..... 109
 Comparison of encoder memory
 contents..... 265
 Configuration..... 299
 Counter
 Clear..... 201
 Equate..... 202
 Invert counting direction 204, 219
 Synchronize..... 203
 Counter check..... 119, 175

D

Data logger..... 326
 Datum shift
 Display..... 208
 EnDat (software option)..... 373
 Fanuc (software option)..... 373
 Mitsubishi (software option). 373
 Panasonic (software option). 373
 Reset..... 209
 Set..... 205
 Yaskawa (software option)... 373
 Diagram
 Adjust view..... 48
 Copy..... 49
 Export..... 49
 Print..... 50
 Send by e-mail..... 49
 Display
 Mouse-over text..... 46
 Power supply..... 45

Display encoder memory..... 249
 Documentation
 Addendum..... 16
 Mounting Instructions..... 16
 Operating Instructions..... 16
 Software Release Notes..... 16
 User's Manual..... 16
 DRIVE-CLiQ
 Special functions..... 338

E

Encoder
 Checking in bus mode..... 335
 Connect..... 60
 Connect in bus operation..... 66
 Connect with ATS code..... 87
 Connect with communication
 code..... 87
 Connect with monitoring
 identifier..... 62
 Disconnect..... 79
 Inspect (EnDat 2.1)..... 194
 Inspect (EnDat 2.2)..... 194
 Inspect (EnDat 3)..... 278
 Inspect (proprietary interfaces)... 194
 Inspect (sinusoidal incremental
 signals)..... 92
 Inspect (square-wave
 incremental signals)..... 154
 Interfaces..... 25
 Measuring method..... 24
 Mounting..... 86
 Signals..... 35
 Values..... 35
 Encoder configuration
 Adapt view..... 252
 Compare..... 265
 Configure..... 299
 Edit..... 255
 Load..... 248, 251
 Load from file..... 254, 297
 Overviews..... 261
 Save..... 254
 Save to file..... 297
 Set write protection..... 259
 Transfer to encoder..... 260
 Write-protected memory areas.... 263
 Encoder database
 Update..... 40
 Encoder diagnostics..... 27
 Connect..... 63
 Encoder information... 152, 191, 214
 Encoders
 Signal converter..... 26
 Encoder settings..... 86

Encoder status..... 294
 EnDat 3
 Signal adapter..... 31
 EnDat 3 tests..... 279
 Error messages..... 198, 261

F

Fanuc
 Special functions..... 354
 Firmware update..... 46
 Functional-safety encoder check.... 233,
 317
 Save log..... 248

H

HSP
 Deactivate..... 107

I

ID label..... 296
 Incremental signal..... 93, 155, 211
 Adjust tolerance limits (software
 option)..... 366
 Analog screen..... 94
 Counter view..... 115, 172
 Customizing screen (software
 option)..... 367
 Delete notes..... 136, 188
 Display notes..... 136, 188
 Homing – Limit view..... 130, 180
 Level view..... 156
 Logic view..... 164
 Note view..... 136, 187
 Protocol view..... 134, 185
 PWT view..... 126
 X/Y graph..... 95
 Y/t graph..... 96
 Informational notes..... 20
 Installation
 Procedure..... 39
 Installing drivers..... 40
 Interface
 Documentation..... 47

L

Log
 Insert address..... 57
 Insert logo..... 57
 Insert signature..... 57
 Save..... 333
 Log/Protocol
 Save..... 135, 186
 logic analysis..... 169

M

Malfunctions
 Troubleshooting..... 376
 Mitsubishi

- Special functions..... 357
 - Monitoring mode..... 29
 - Without signal adapter..... 30
 - With signal adapter..... 29
 - Mounting wizard..... 86
- O**
- Online diagnostics..... 219
 - Opening documentation..... 47
 - Operating mode
 - Encoder diagnostics..... 27
 - Monitoring mode..... 29
 - Operating status data..... 325
 - operating status error sources... 210
 - Operation
 - Return to last view..... 45
 - Overview of functions..... 33
- P**
- Panasonic
 - Special functions..... 358
 - Personnel..... 21
 - Electrical specialist..... 21
 - Qualified personnel..... 21
 - Position display..... 195, 280
 - Multidimensional..... 285
 - PWM
 - Operating instructions..... 47
 - Select as testing device..... 55
- R**
- Recording..... 137
- S**
- Safety precautions..... 20
 - Saving the encoder memory..... 268
 - Sensor technology..... 295
 - Setting write-protection..... 315
 - Signal adapter
 - EnDat 3..... 31
 - Software
 - Configuration..... 52
 - Display..... 45
 - Download..... 38
 - Exiting..... 47
 - Information..... 47
 - Installation..... 38
 - Installing device drivers..... 40
 - Operating elements..... 45
 - Select PWM..... 55
 - Starting..... 46
 - Uninstallation..... 41
 - Update..... 40
 - User interface..... 44
 - Software option
 - Deactivate..... 54
 - Enabling..... 53
 - Software options..... 364
 - SSI
 - Special functions..... 361
 - status messages..... 209
 - Status reports..... 198
 - Symbols and fonts used for marking text..... 18
 - System requirements..... 38
- T**
- Tape tensioning..... 86
 - Temperature display..... 273
 - PT 1000 conversion..... 273
 - Tolerances..... 36
 - Touch probe
 - Connect..... 80
 - Disconnect..... 84
 - Transceiver unit..... 26
- U**
- Units..... 36
- V**
- Valuation numbers..... 219, 264
 - Voltage display... 150, 189, 212, 334
 - Deactivate terminating resistor... 151, 190, 213
- W**
- Warnings..... 198, 261
- Y**
- Yaskawa
 - Special functions..... 359

HEIDENHAIN

DR. JOHANNES HEIDENHAIN GmbH

Dr.-Johannes-Heidenhain-Straße 5

83301 Traunreut, Germany

☎ +49 8669 31-0

☎ +49 8669 32-5061

info@heidenhain.de

Technical support ☎ +49 8669 32-1000

Measuring systems ☎ +49 8669 31-3104

service.ms-support@heidenhain.de

NC support ☎ +49 8669 31-3101

service.nc-support@heidenhain.de

NC programming ☎ +49 8669 31-3103

service.nc-pgm@heidenhain.de

PLC programming ☎ +49 8669 31-3102

service.plc@heidenhain.de

APP programming ☎ +49 8669 31-3106

service.app@heidenhain.de

www.heidenhain.com