

For mounting the linear scale and scale tapes, please refer to the separate Mounting Instructions.
Für Montage des Maßstabes und Maßbänder bitte separate Anleitung beachten.
Pour le montage de la règle et des rubans de mesure, veuillez tenir compte des instructions distinctes.
Per il montaggio della riga graduata e dei nastri graduati attenersi alle istruzioni separate.
Para el montaje de la regla y las cintas de medida deben consultarse las instrucciones de montaje suministradas por separado.



www.heidenhain.com/documentation

HEIDENHAIN

Mounting Instructions
Montageanleitung
Instructions de montage
Istruzioni di montaggio
Instrucciones de montaje

AK LIC 411
AK LIC 413
AK LIC 419

Scanning Head
Abtastkopf
Tête caprice
Testina di scansione
Cabezal captador

03/2024

Contents
Inhalt
Sommaire
Indice
Indice

Page
3 Warnings
4 Items Supplied
5 Mounting Procedure
6 Mounting Options for the Scanning Head
11 Mounting
13 Final Steps
14 Adjustment and Diagnosis

Seite
3 *Warnhinweise*
4 *Lieferumfang*
5 *Hinweise zur Montage*
6 *Montagemöglichkeiten des Abtastkopfes*
11 *Montage*
13 *Abschließende Arbeiten*
14 *Justage und Diagnose*

Page
3 Avertissements
4 Contenu de la fourniture
5 Procédure de montage
6 Possibilités de montage de la tête caprice
11 Montage
13 Opérations finales
14 Réglage et diagnostic

Pagina
3 *Avvertenze*
4 *Standard di forniture*
5 *Avvertenze per il montaggio*
6 *Varianti di montaggio della testina*
11 *Montaggio*
13 *Operazioni finali*
14 *Taratura e diagnosi*

Página
3 Advertencias
4 Suministro
5 Indicaciones para el montaje
6 Posibilidades de montaje del cabezal
11 Montaje
13 Trabajos finales
14 Ajuste y diagnóstico

Dimensions in mm
Maße in mm
Cotes en mm
Dimensioni in mm
Dimensiones en mm

Warnings
Warnhinweise
Avertissements
Avvertenze
Advertencias

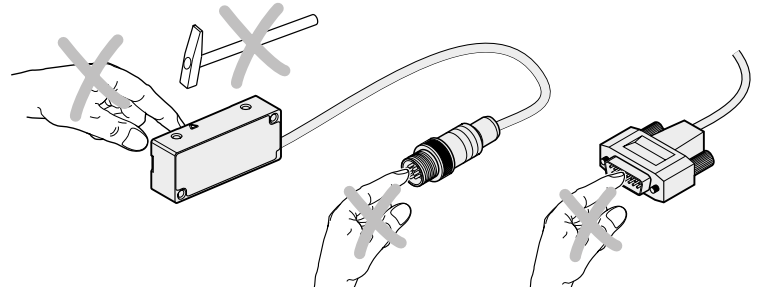
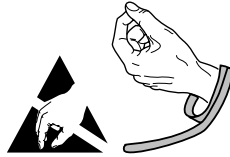

Note: Mounting and commissioning is to be conducted by a qualified specialist under compliance with local safety regulations.
Do not engage or disengage any connections while under power.
The system must be disconnected from power.

Achtung: Die Montage und Inbetriebnahme ist von einer qualifizierten Fachkraft unter Beachtung der örtlichen Sicherheitsvorschriften vorzunehmen.
Die Steckverbindung darf nur spannungsfrei verbunden oder gelöst werden.
Die Anlage muss spannungsfrei geschaltet sein!

Attention : le montage et la mise en service doivent être assurés par un personnel qualifié dans le respect des consignes de sécurité locales.
Le connecteur ne doit être connecté ou déconnecté qu'hors potentiel.
L'équipement doit être connecté hors potentiel !

Attenzione: il montaggio e la messa in funzione devono essere eseguite da personale qualificato nel rispetto delle norme di sicurezza locali.
I cavi posso essere collegati o scollegati solo in assenza di tensione.
L'impianto deve essere spento!

Atención: El montaje y la puesta en marcha deben ser realizados por un especialista cualificado, observando las prescripciones locales de seguridad.
Conectar o desconectar el conector sólo en ausencia de tensión.
¡La instalación debe ser conectada en ausencia de tensión!

The tightening torques of the mounting screws are only valid for mounting on steel!

Anzugsmomente der Befestigungsschrauben nur gültig für Anbau auf Stahl!

Les couples de serrage mentionnés pour les vis de fixation ne sont valables que pour un montage sur acier !

Coppie di serraggio delle viti di fissaggio valide soltanto per montaggio su acciaio!

¡El par de apriete de los tornillos de fijación es sólo válido para el montaje sobre acero!

Items Supplied

Lieferumfang

Contenu de la fourniture

Standard di forniture

Suministro

LIC 41x scanning head, spacer foil 0.15 mm/0.75 mm

Abtastkopf LIC 41x, Abstandsfolie 0,15 mm/0,75 mm

Tête caprice LIC 41x, feuille d'écartement 0,15 mm/0,75 mm

Testina LIC 41x, pellicola distanziale 0,15 mm/0,75 mm

Cabezal de captación LIC 41x, lámina espaciadora 0,15 mm/0,75 mm

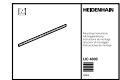

For adjustment and diagnosis, HEIDENHAIN offers the PWM 20/21 with the ATS adjustment and testing software.

Zur Justage und Diagnose bietet HEIDENHAIN das PWM 20/21 mit Justage- und Prüfsoftware ATS an.

Pour le réglage et le diagnostic, HEIDENHAIN propose le PWM 20/21 avec le logiciel de réglage et de contrôle ATS.

Per la taratura e la diagnostica HEIDENHAIN propone il tool PWM 20/21 con Adjusting and Testing Software ATS.

HEIDENHAIN ofrece para el ajuste y diagnóstico el PWM 20/21 junto con el software de prueba y ajuste ATS.

Mounting Procedure
Hinweise zur Montage
Procédure de montage
Avvertenze per il montaggio
Indicaciones para el montaje

Remove the protective cover. If present, remove the protective film from the scale prior to operation.

Schutzkappe entfernen. Falls vorhanden, Schutzfolie von Maßverkörperung vor Inbetriebnahme abziehen.

Retirer le bouchon de protection. Le cas échéant, retirer le film protecteur du ruban de mesure ou barreau de verre avant la mise en service.

Rimuovere le protezioni. Se presente, rimuovere la pellicola protettiva dal nastro graduato o riga graduata prima della messa in servizio.

Retirar la tapa protectora. Si está presente, retire la película protectora de la regla o antes de la puesta en marcha.

If necessary, clean the graduation and the scanning head with a lint-free cloth and isopropyl alcohol.

Bei Bedarf Teilung und Abtastkopf mit fussselfreiem Tuch und Isopropylalkohol reinigen.

En cas de besoin, nettoyer la division et la tête caprice avec un chiffon sans peluches et de l'alcool isopropylique.

All'occorrenza, pulire la graduazione e la testina di scansione con un panno pulito che non lascia pelucchi e alcol isopropilico.

Si fuera necesario, limpiar el divisor y el cabezal lector con un trapo limpio que no suelte pelusa y alcohol isopropileno.

Minimum distance from sources of interference.

Mindestabstand von Störquellen.

Distance minimale avec les sources de perturbation.

Distanza minima della fonte di disturbo.

Distancia mínima respecto a las fuentes de interferencias.

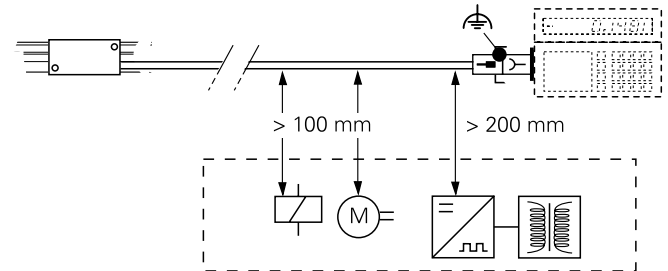
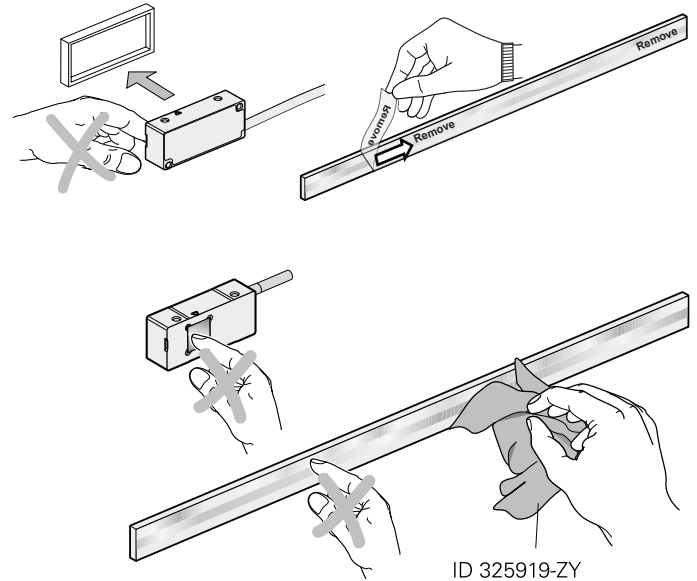

Mounting Options for the Scanning Head
Montagemöglichkeiten des Abtastkopfes
Possibilités de montage de la tête caprice
Varianti di montaggio della testina
Posibilidades de montaje del cabezal

LIC 4003

Scale fastening with PRECIMET adhesive mounting film
Befestigung des Maßstabs mit Montagefilm PRECIMET
 Fixation de la règle avec le film de montage PRECIMET
Fissaggio della riga con la pellicola di montaggio PRECIMET
 Sujeción de la regla con película de montaje PRECIMET

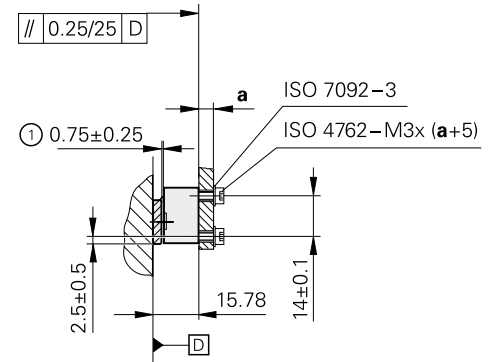
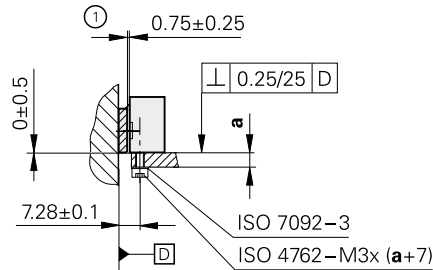
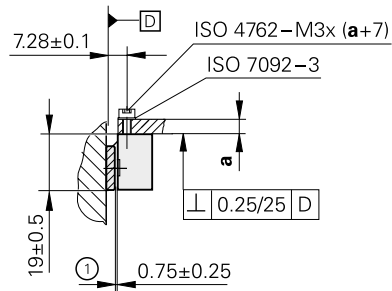

- ① = Mounting clearance between the scanning head and graduation
Montageabstand Abtastkopf zu Teilung
 Distance de montage entre la tête caprice et la gravure
Distanza di montaggio tra testina di scansione e graduazione
 Distancia de montaje del cabezal lector al divisor

LIC 4003

Scale fastening with fixing clamps
Befestigung des Maßstabs mit Spannpratzen
Fixation de la règle avec des griffes de serrage
Fissaggio della riga con graffette
Sujeción de la regla con mordazas excéntricas

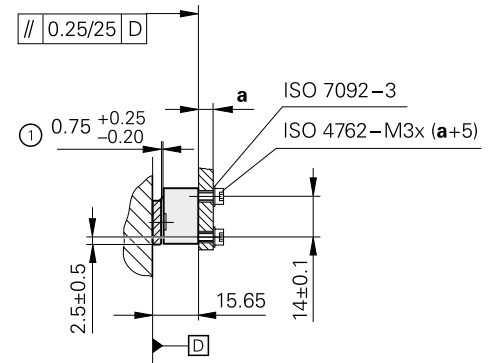
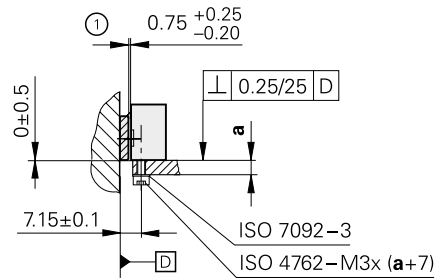
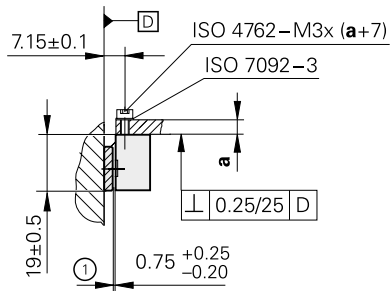

- ① = Mounting clearance between the scanning head and graduation
Montageabstand Abtastkopf zu Teilung
Distance de montage entre la tête caprice et la gravure
Distanza di montaggio tra testina di scansione e graduazione
Distancia de montaje del cabezal lector al divisor

LIC 4005

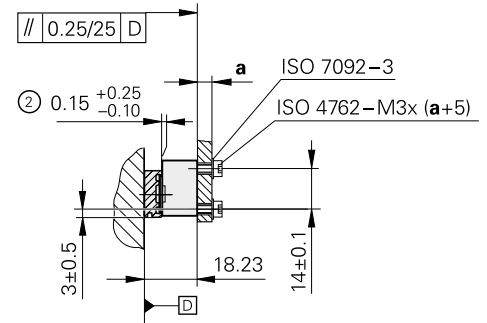
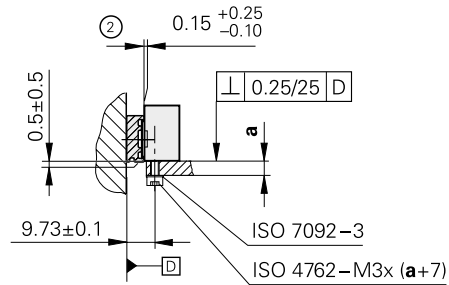
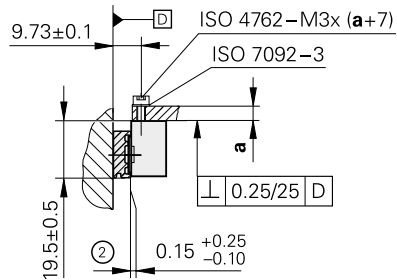

- ② = Mounting clearance between the scanning head and scale tape carrier
Montageabstand Abtastkopf zu Maßbandträger
 Distance de montage entre la tête caprice et le support du ruban de mesure
Distanza di montaggio tra testina di scansione e supporto nastro
 Distancia de montaje del cabezal lector al soporte de la cinta de medida

LIC 4007

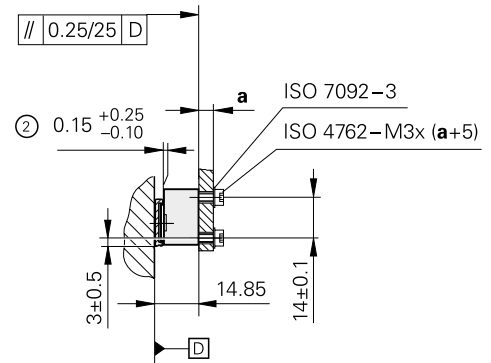
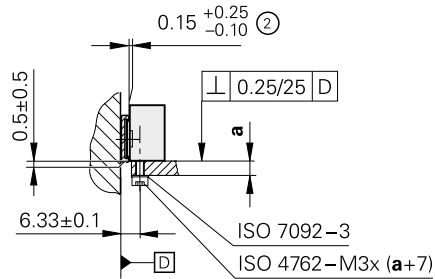
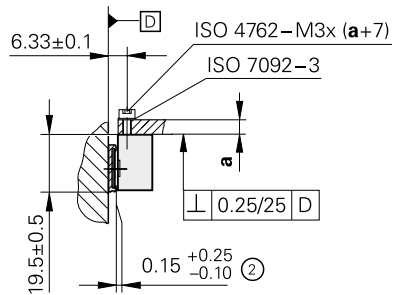

- ② = Mounting clearance between the scanning head and scale tape carrier
Montageabstand Abtastkopf zu Maßbandträger
 Distance de montage entre la tête caprice et le support du ruban de mesure
Distanza di montaggio tra testina di scansione e supporto nastro
 Distancia de montaje del cabezal lector al soporte de la cinta de medida

LIC 4009

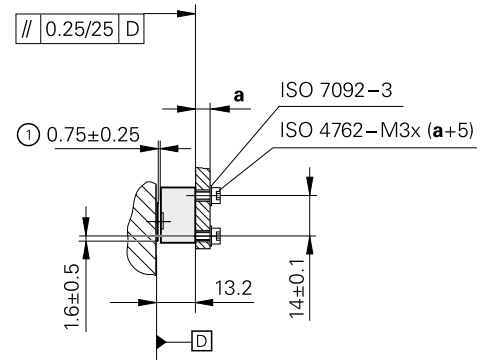
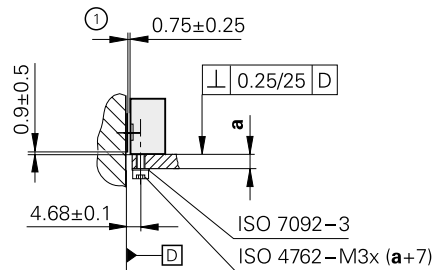
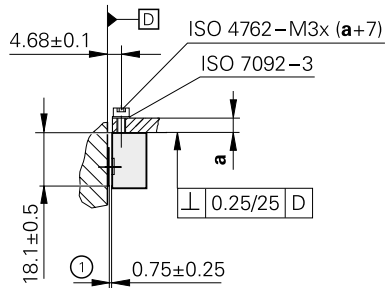

- ① = Mounting clearance between the scanning head and graduation
Montageabstand Abtastkopf zu Teilung
 Distance de montage entre la tête caprice et la gravure
 Distanza di montaggio tra testina di scansione e graduazione
 Distancia de montaje del cabezal lector al divisor

Mounting
Montage
Montage
Montaggio
Montaje

Use the spacer foil to set the mounting clearance.
 Screw on the scanning head.

*Mit Abstandsfolie Montageabstand einstellen.
 Abtastkopf anschrauben.*

Déterminer la distance de montage à l'aide de la feuille d'écartement.
 Visser la tête caprice.

*Regolare la distanza di montaggio con pellicola distanziale.
 Avvitare la testina di scansione.*

Ajustar la distancia de montaje con la lámina separadora.
 Atornillar el cabezal lector.

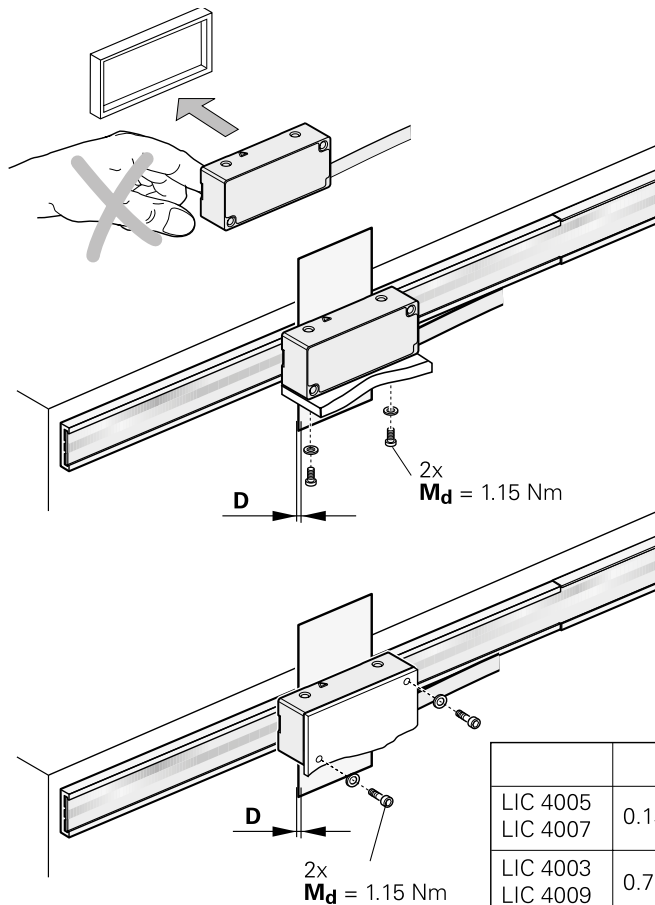

	D
LIC 4005	0.15 mm
LIC 4007	
LIC 4003	0.75 mm
LIC 4009	





Permissible bending radii of connecting cable.
 R₁: for rigid configuration, R₂: for frequent flexing

Zulässige Biegeradien der Anschlusskabel.
 R₁: Dauerbiegung, R₂: Wechselbiegung

Rayons de courbure admissibles sur le câble de raccordement.
 R₁ : Courbure permanente, R₂ : Courbure fréquente

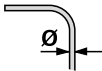
Raggio di curvatura consentito per il cavo di collegamento:
 R₁: con curvatura fissa, R₂: con flessioni ripetute

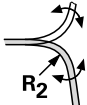
Radios de torsión admisibles en los cables.
 R₁: Torsión continua, R₂: Torsión variable

		
Ø 3.7 mm	R ₁ ≥ 8 mm	R ₂ ≥ 40 mm
Ø 8 mm	R ₁ ≥ 40 mm	R ₂ ≥ 100 mm
		

Final Steps

Abschließende Arbeiten

Opérations finales

Operazioni finali

Trabajos finales

Check the resistance between the connector housing and the machine.

Desired value: 1 Ω max.

Elektrischen Widerstand zwischen Steckergehäuse und Maschine prüfen.

Sollwert: 1 Ω max.

Tester la résistance électrique entre le carter de la prise et la machine.

Valeur nominale: 1 Ω max.

Controllare la resistenza elettrica tra l'alloggiamento del connettore e la macchina.

Valore nominale: 1 Ω max.

Comprobar la resistencia eléctrica entre la carcasa del conector y la máquina.

Valor nominal: 1 Ω máx.

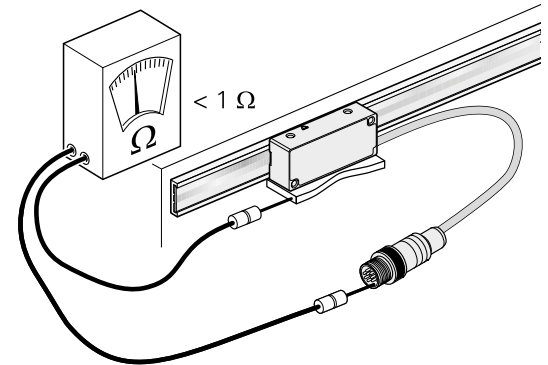

Adjustment and Diagnosis

Justage und Diagnose

Réglage et diagnostic

Taratura e diagnosi

Ajuste y diagnóstico

For adjustment of the signals, please use the provided "Mounting wizard for LIC 41xx" Mounting Instructions.

Zum Abgleich der Signale bitte beiliegende Montageanleitung „Anbauassistent für LIC 41xx“ verwenden.

Pour le réglage des signaux, veuillez consulter les instructions de montage ci-jointes : «Assistant au montage de la LIC 41xx».

Per la taratura dei segnali utilizzare le istruzioni di montaggio allegate "Assistente al montaggio per LIC 41xx".

Utilizar para el ajuste de las señales las instrucciones de montaje adjuntas "Asistente para el montaje para LIC 41xx".

} ID 1117241

HEIDENHAIN

DR. JOHANNES HEIDENHAIN GmbH

Dr.-Johannes-Heidenhain-Straße 5

83301 Traunreut, Germany

☎ +49 8669 31-0

[FAX] +49 8669 32-5061

info@heidenhain.de

Technical support [FAX] +49 8669 32-1000

Measuring systems ☎ +49 8669 31-3104
service.ms-support@heidenhain.de

NC support ☎ +49 8669 31-3101
service.nc-support@heidenhain.de

NC programming ☎ +49 8669 31-3103
service.nc-pgm@heidenhain.de

PLC programming ☎ +49 8669 31-3102
service.plc@heidenhain.de

APP programming ☎ +49 8669 31-3106
service.app@heidenhain.de

www.heidenhain.com

1113917-01



1113917 · Ver03 · 01