

Zubehör separat bestellen:  
 Accessories are to be ordered separately:  
 Commander les accessoires séparément:  
 Accessorio da ordinare separatamente:  
 Pedir accesorios por separado:

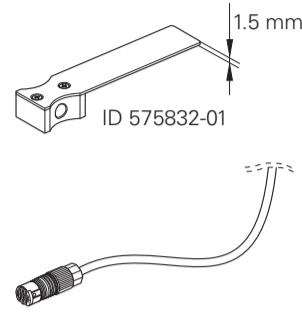

# HEIDENHAIN

Montageanleitung  
 Mounting Instructions  
 Instructions de montage  
 Istruzioni di montaggio  
 Instrucciones de montaje

## LF 185 C

7/2013



802456-01-A-01 · Printed in Germany

### Allgemeine Hinweise · General Information · Informations générales · Informazioni generali · Información general



**Achtung:** Die Montage und Inbetriebnahme ist von einer qualifizierten Fachkraft unter Beachtung der örtlichen Sicherheitsvorschriften vorzunehmen.

Die Steckverbindung darf nur spannungsfrei verbunden oder gelöst werden.

Die Anlage muss spannungsfrei geschaltet sein!

**Note:** Mounting and commissioning is to be conducted by a qualified specialist under compliance with local safety regulations.

Do not engage or disengage any connections while under power.

The system must be disconnected from power.

**Attention:** Le montage et la mise en service doivent être assurés par un personnel qualifié dans le respect des consignes de sécurité locales.

Le connecteur ne doit être connecté ou déconnecté qu'hors potentiel.

L'équipement doit être connecté hors potentiel!

**Attenzione:** Il montaggio e la messa in funzione devono essere eseguite da personale qualificato nel rispetto delle norme di sicurezza locali.

I cavi possono essere collegati o scollegati solo in assenza di tensione.

L'impianto deve essere spento!

**Atención:** El montaje y la puesta en marcha deben ser realizados por un especialista cualificado, observando las prescripciones locales de seguridad.

Conectar o desconectar el conector sólo en ausencia de tensión.

¡La instalación debe ser conectada en ausencia de tensión!

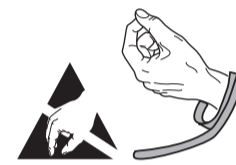

Maße in mm  
 Dimensions in mm  
 Cotes en mm  
 Dimensioni in mm  
 Dimensiones en mm

### Allgemeine Hinweise · General Information · Informations générales · Informazioni generali · Información general

Anbaufläche sauber und lackfrei.  
 Mounting surface clean and free of paint.  
 Surface de montage propre et exempte de peinture.  
 Superficie di montaggio pulita e non verniciata.  
 Superficie de montaje limpia y libre de barniz.

ML = Messlänge  
 Measuring length  
 Longueur de mesure  
 Corsa utile  
 Longitud de medición

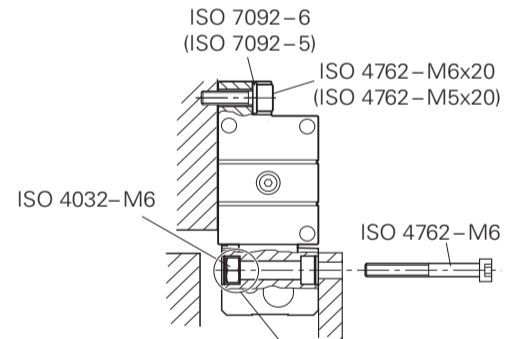
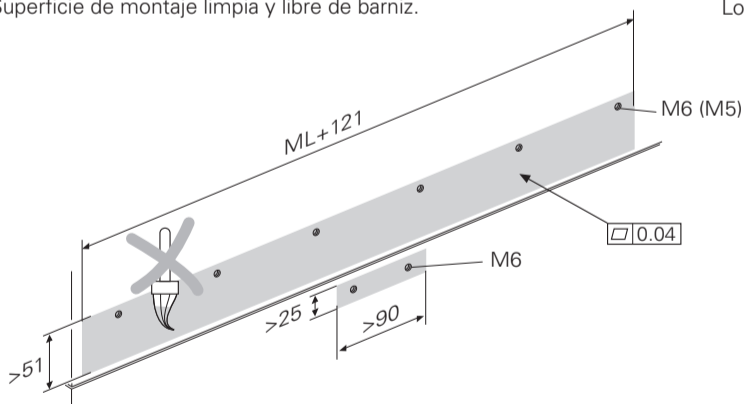

Mutter M6 einrasten  
 Engage the M6 nut  
 Engager l'écrou M6  
 Inserire il dado M6  
 Engranar la tuerca M6

### Allgemeine Hinweise · General Information · Informations générales · Informazioni generali · Información general

Kabelanschluss beidseitig verwendbar.  
 Cable connection usable at either end.  
 Raccordement du câble possible des deux côtés.  
 Il cavo può essere connesso ai due lati della testina.  
 Conexión de cable utilizable por ambos lados.

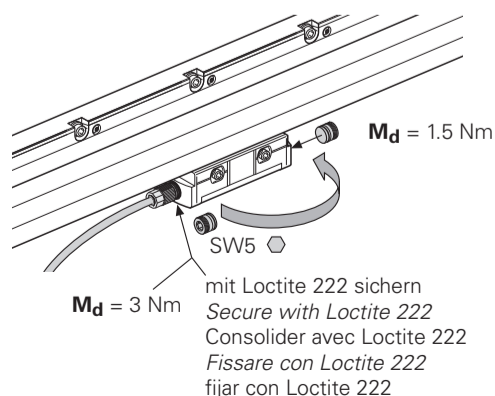

Zum Bewegen 1/4 Umdrehung lösen.  
 Loosen by 1/4 revolution for movement.  
 Dévisser de 1/4 de tour pour déplacement.  
 Allentare di 1/4 di giro.  
 Aflojar 1/4 de vuelta.

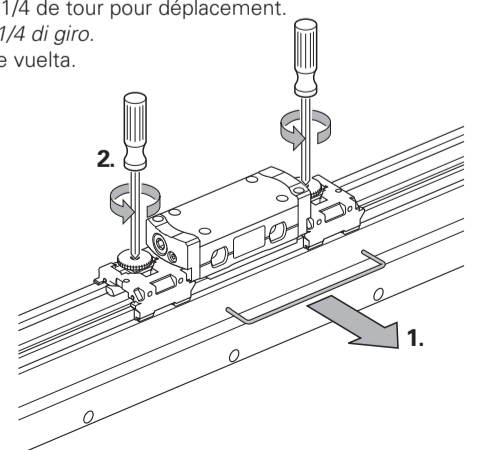

Montage · Assembly · Montage · Montaggio · Montaje

F = Maschinenführung  
Machine guideway  
Guidage de la machine  
Guida della macchina  
Guía de la máquina

⊙ = Beginn der Messlänge ML  
Begin. of meas. length ML  
Début longueur utile ML  
Inizio lunghezza di misura ML  
Comienzo longitud útil ML

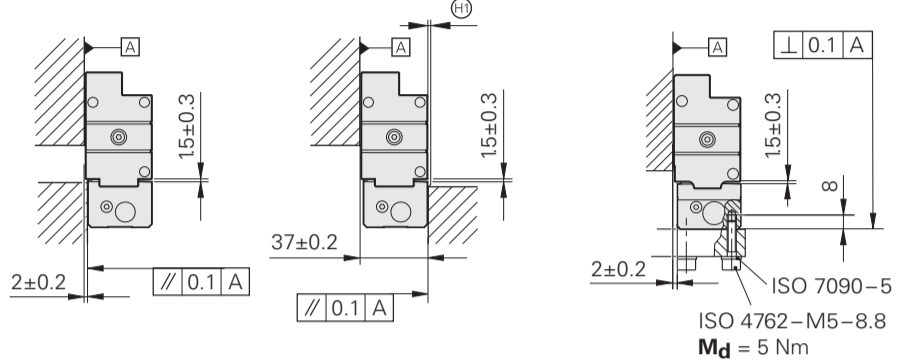
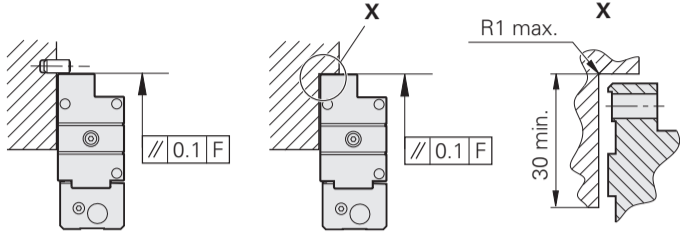
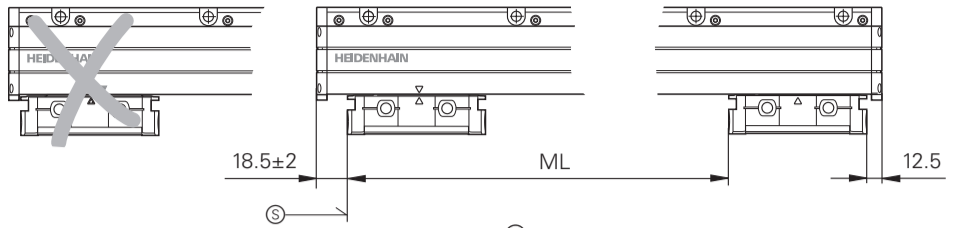

⊕ = kein alternatives kundenseitiges Anschlussmaß, im Gegensatz zu LS/LC 100  
No alternative required mating dimension, as opposed to LS/LC 100  
Pas de cote de raccordement requise alternative, contrairement à LS/LC 100  
Nessuna misura alternativa per il collegamento lato cliente, contrariamente a LS/LC 100  
Sin necesidad de cota de montaje alternativa del lado del cliente, al contrario que la LS/LC 100

1.

P = Punkte zum Ausrichten  
Points for alignment  
Points pour alignement  
Punti per l'allineamento  
Puntos para la alineación

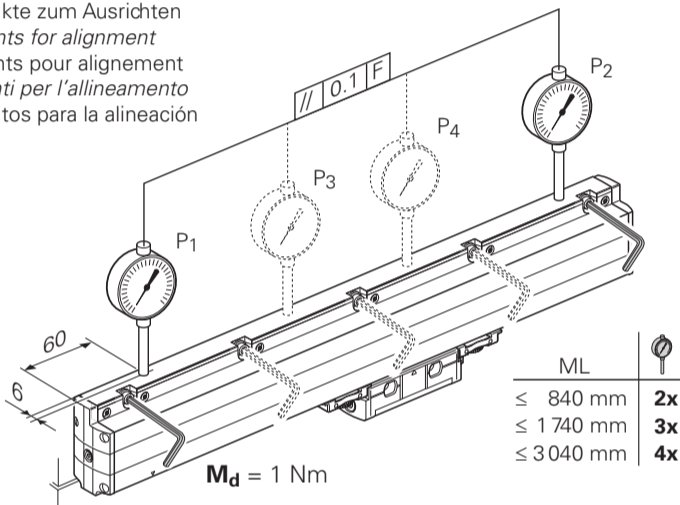

2.

M5:  $M_d = 5 \text{ Nm}$   
M6:  $M_d = 8 \text{ Nm}$

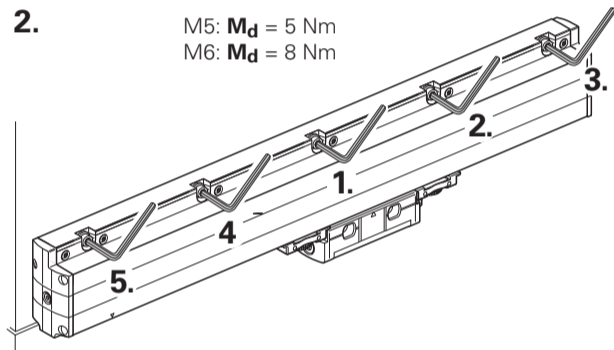

3.

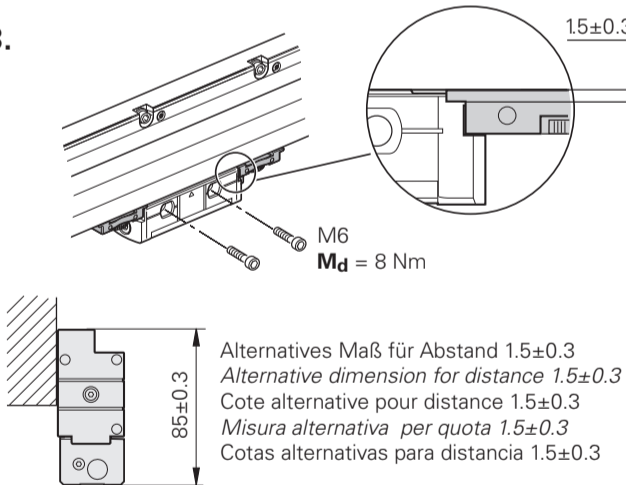

4.

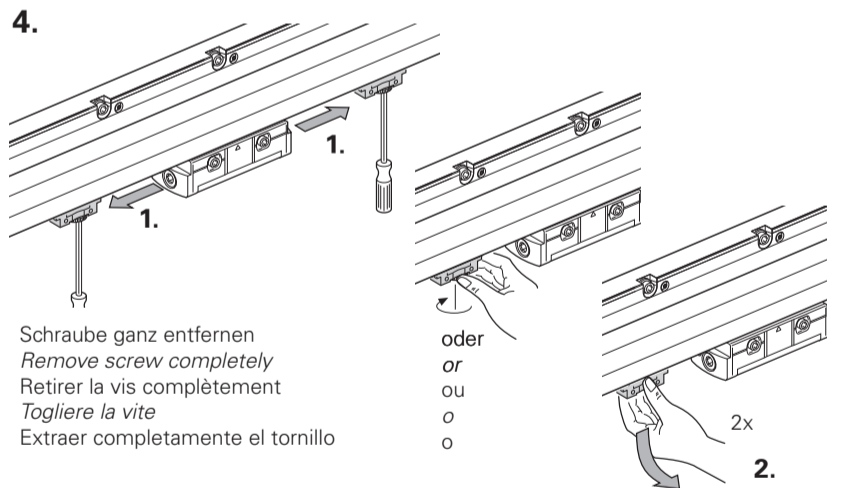

Abschließende Arbeiten · Final Steps · Opérations finales · Operazioni finali · Trabajos finales

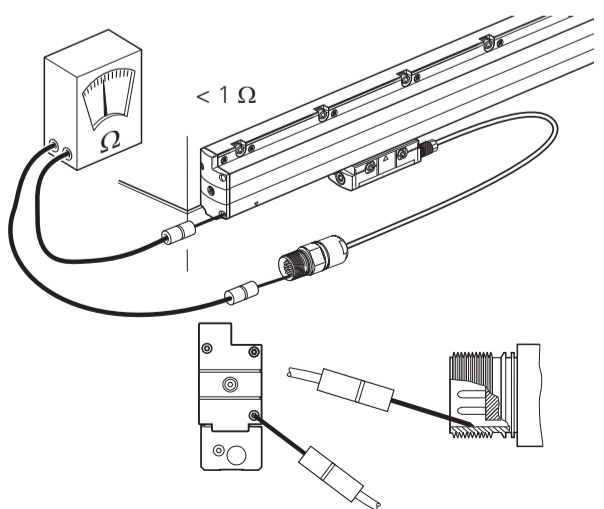

⊕ = Druckluftanschluss beidseitig möglich  
Compressed-air connection usable at either end  
Raccordement d'air comprimé possible des deux côtés  
Connessioni per aria compressa sui due lati  
Toma de aire comprimido posible por ambos lados

Bevorzugt zu verwenden  
Preferred for use  
Utilisation préconisée  
Da utilizzare preferibilmente  
Utilizar preferentemente

DA 400

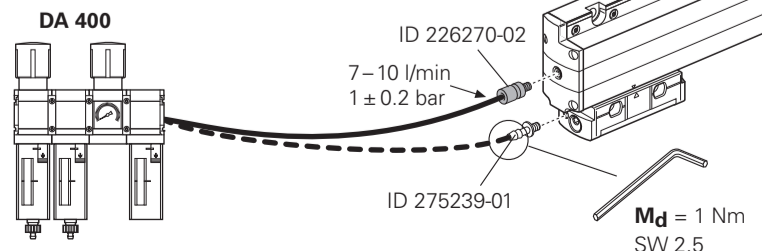

senkrechter Anbau  
vertical mounting  
montage verticale  
montaggio verticale  
montaje vertical

