

Retain the encoder ID label.
 Geräteschild-Aufkleber aufbewahren.
 Conserver l'autocollant de l'étiquette signalétique.
 Conservare targhetta adesiva.
 Conservar la etiqueta adhesiva del aparato.

Order separately:
 Separat bestellen:
 A commander séparément:
 Ordinare a parte:
 Para pedir por separado:

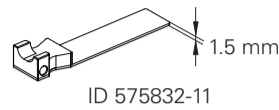

HEIDENHAIN

Mounting Instructions
 Montageanleitung
 Instructions de montage
 Istruzioni di montaggio
 Instrucciones de montaje

LC 1x5

Absolute linear encoder
 Absolutes Längenmessgerät
 Système de mesure linéaire absolu
 Sistema di misura assoluto
 Sistema lineal de medida absoluto



07/2021

737909-03-A-01 · Printed in Germany

General Information . Allgemeine Hinweise . Informations générales . Informazioni generali . Información general

! **Note:** Mounting and commissioning is to be conducted by a qualified specialist under compliance with local safety regulations. Do not engage or disengage any connections while under power. The system must be disconnected from power.

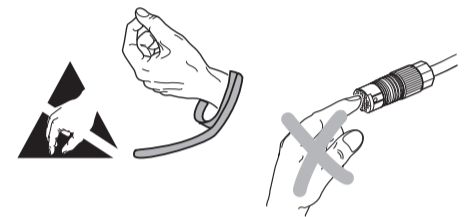

Dimensions in mm
 Maße in mm
 Cotes en mm
 Dimensioni in mm
 Dimensiones en mm

Achtung: Die Montage und Inbetriebnahme ist von einer qualifizierten Fachkraft unter Beachtung der örtlichen Sicherheitsvorschriften vorzunehmen.

Die Steckverbindung darf nur spannungsfrei verbunden oder gelöst werden.
 Die Anlage muss spannungsfrei geschaltet sein!

Attention: Le montage et la mise en service doivent être assurés par un personnel qualifié dans le respect des consignes de sécurité locales.

Le connecteur ne doit être connecté ou déconnecté qu'hors potentiel.
 L'équipement doit être connecté hors potentiel!

Attenzione: Il montaggio e la messa in funzione devono essere eseguite da personale qualificato nel rispetto delle norme di sicurezza locali.

I cavi posso essere collegati o scollegati solo in assenza di tensione.
 L'impianto deve essere spento!

Atención: El montaje y la puesta en marcha deben ser realizados por un especialista cualificado, observando las prescripciones locales de seguridad.

Conectar o desconectar el conector sólo en ausencia de tensión.
 ¡La instalación debe ser conectada en ausencia de tensión!

General Information . Allgemeine Hinweise . Informations générales . Informazioni generali . Información general

Mounting surface clean and free of paint
 Anbaufläche sauber und lackfrei
 Surface de montage propre et exempte de peinture
 Superficie di montaggio pulita e non verniciata
 Superficie de montaje limpia y libre de barniz

ML = Measuring length
 Messlänge
 Longueur de mesure
 Corsa utile
 Longitud de medición

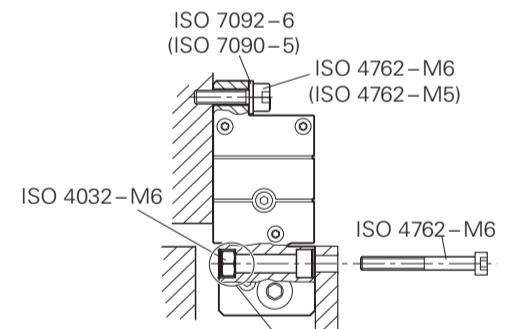
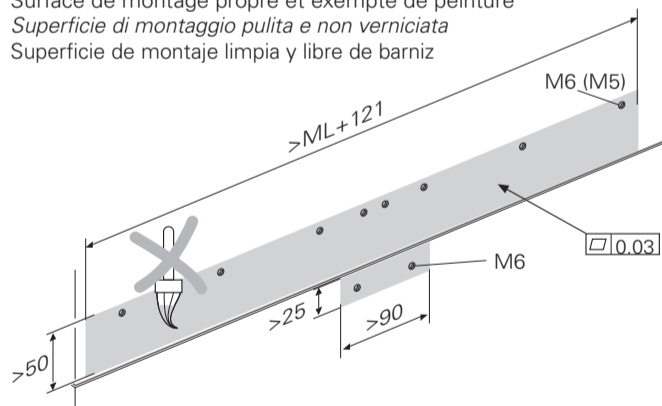

Engage the M6 nut
 Mutter M6 einrasten
 Engager l'écrou M6
 Inserire il dado M6
 Engranar la tuerca M6

General Information . Allgemeine Hinweise . Informations générales . Informazioni generali . Información general

Cable connection usable at either end
 Kabelanschluss beidseitig verwendbar
 Raccordement du câble possible des deux côtés
 Il cavo può essere connesso ai due lati della testina
 Conexión de cable utilizable por ambos lados

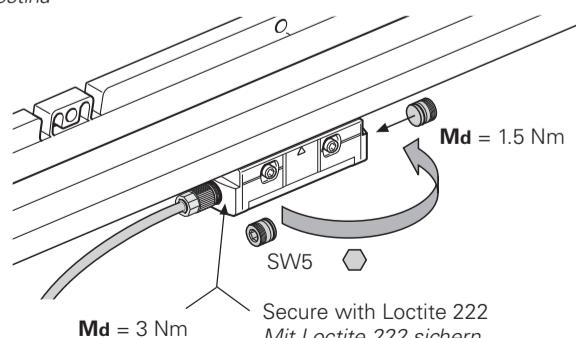

Secure with Loctite 222
 Mit Loctite 222 sichern
 Consolider avec Loctite 222
 Fissare con Loctite 222
 Fijar con Loctite 222

Loosen by 1/4 revolution for movement
 Zum Bewegen 1/4 Umdrehung lösen
 Dévisser de 1/4 de tour pour déplacement
 Allentare di 1/4 di giro
 Aflojar 1/4 de vuelta

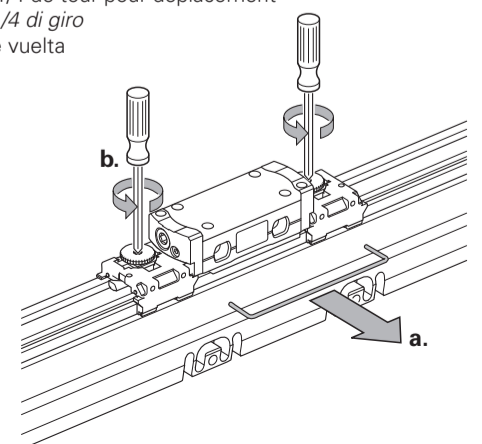

Assembly · Montage · Montage · Montaggio · Montaje

F = Machine guideway
 Maschinenführung
 Guidage de la machine
 Guida della macchina
 Guía de la máquina

Ⓢ = Begin. of meas. length ML
 Beginn der Messlänge ML
 Début longueur utile ML
 Inizio lunghezza di misura ML
 Comienzo longitud útil ML

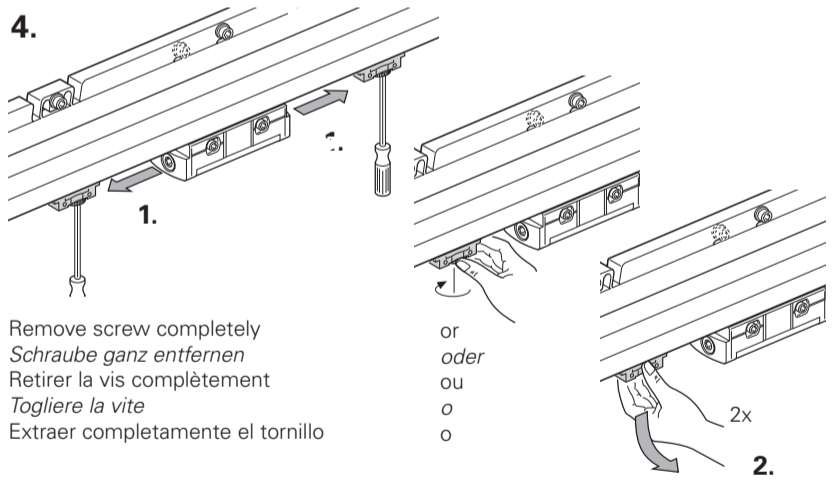
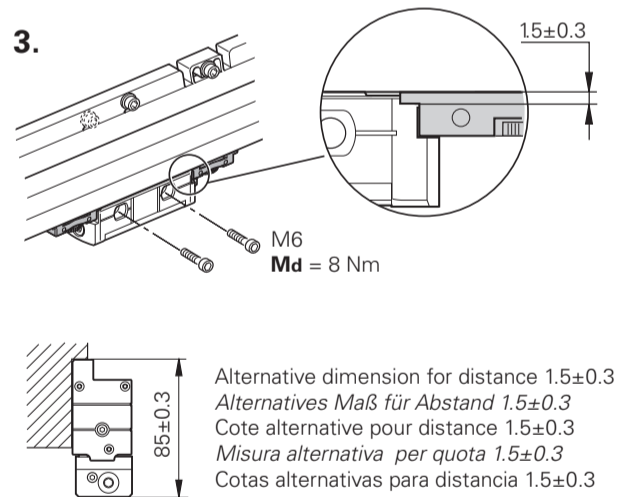
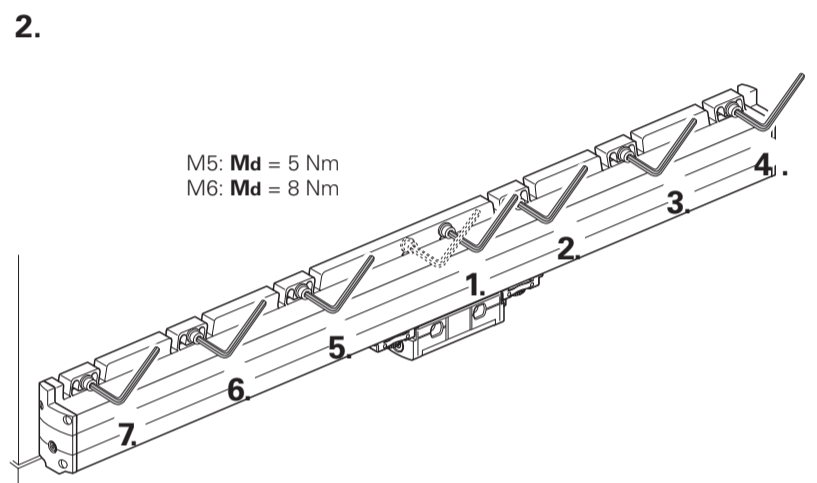
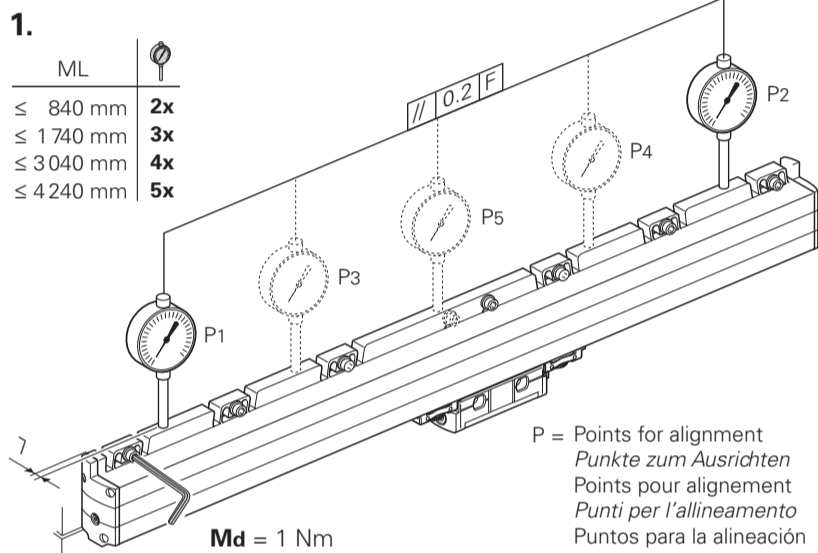
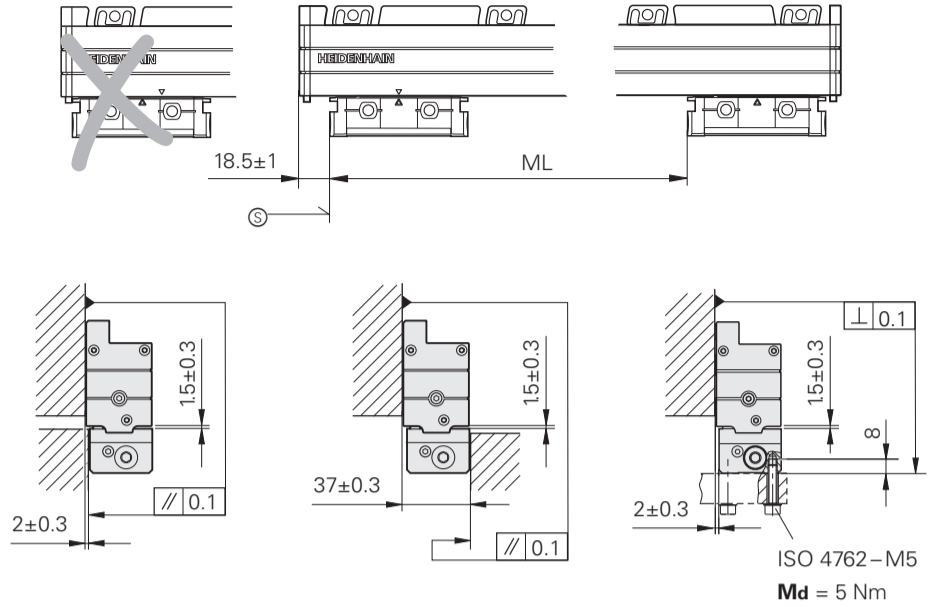
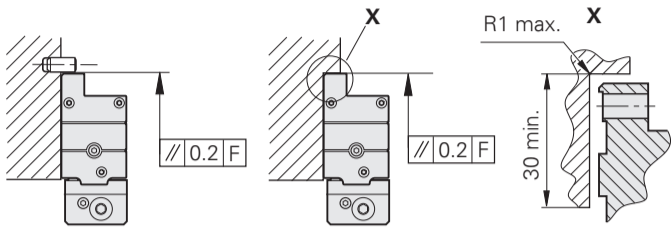

Final Steps · Abschließende Arbeiten · Opérations finales · Operazioni finali · Trabajos finales

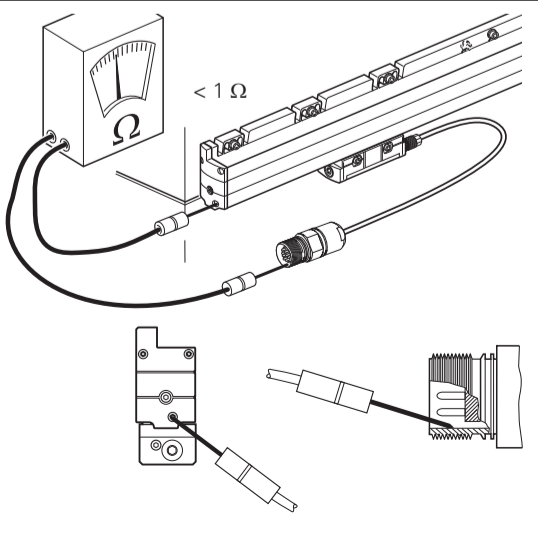

Ⓢ = Compressed-air connection usable at either end
 Druckluftanschluss beidseitig möglich
 Raccordement d'air comprimé possible des deux côtés
 Connessioni per aria compressa sui due lati
 Toma de aire comprimido posible por ambos lados

Preferred for use
 Bevorzugt zu verwenden
 Utilisation préconisée
 Da utilizzare preferibilmente
 Utilizar preferentemente

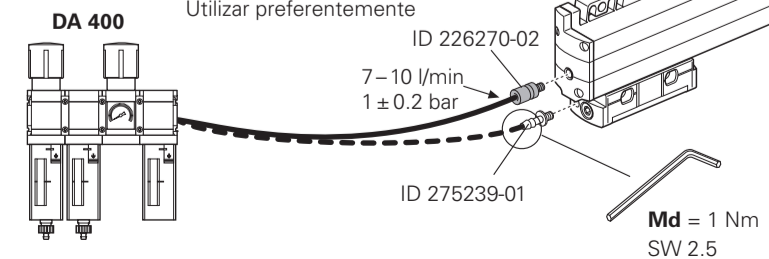

Vertical mounting
 Senkrechter Anbau
 Montage vertical
 Montaggio verticale
 Montaje vertical

