

1 2 3 4 5 6 7 8 9 10 11 12

A B C D E F G H

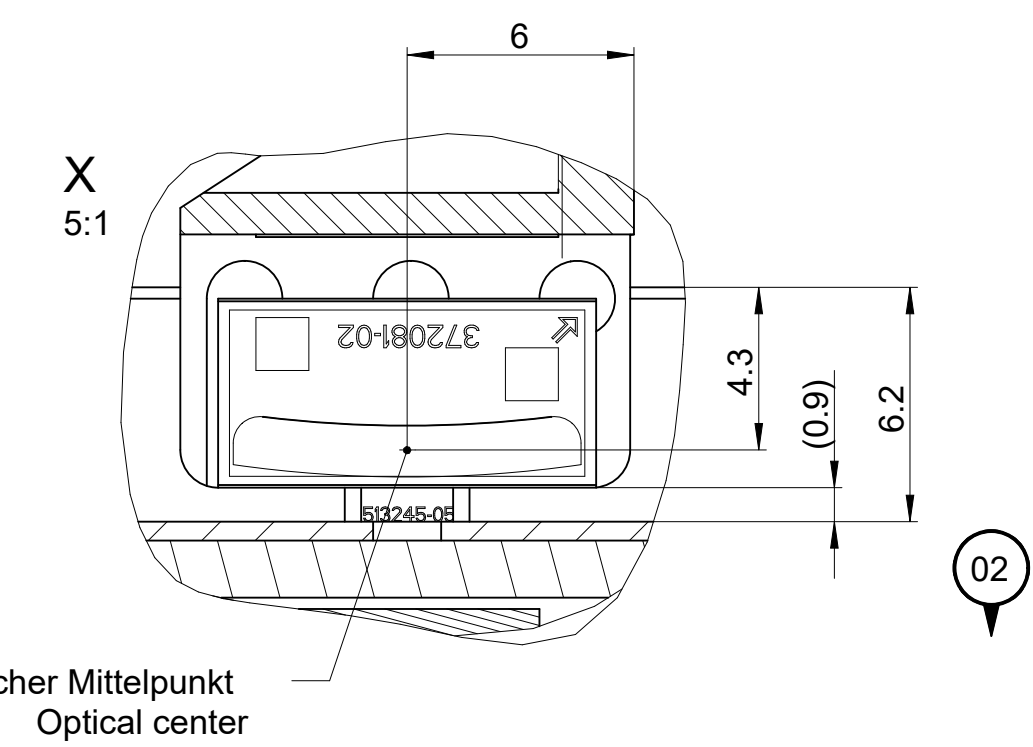
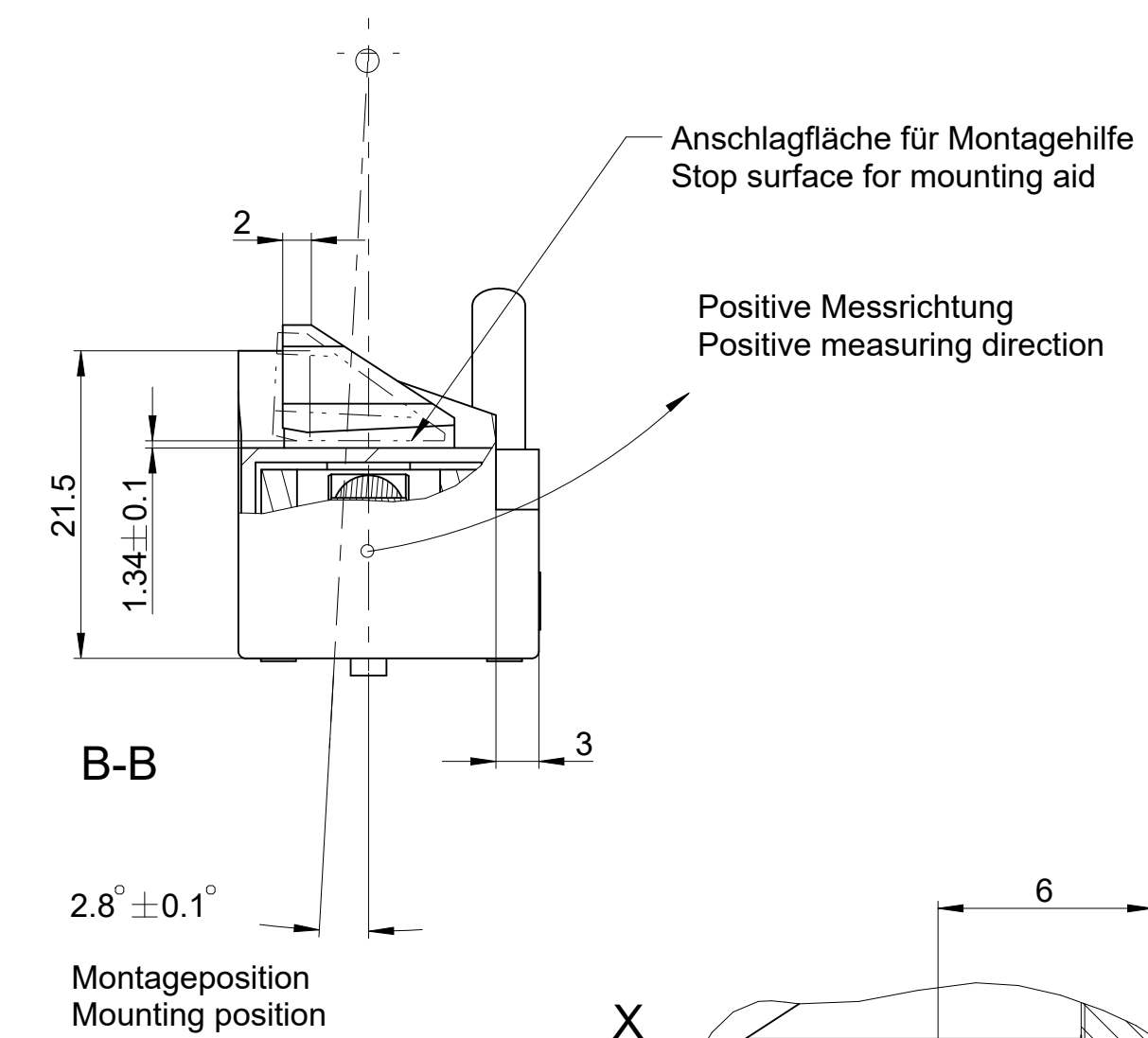
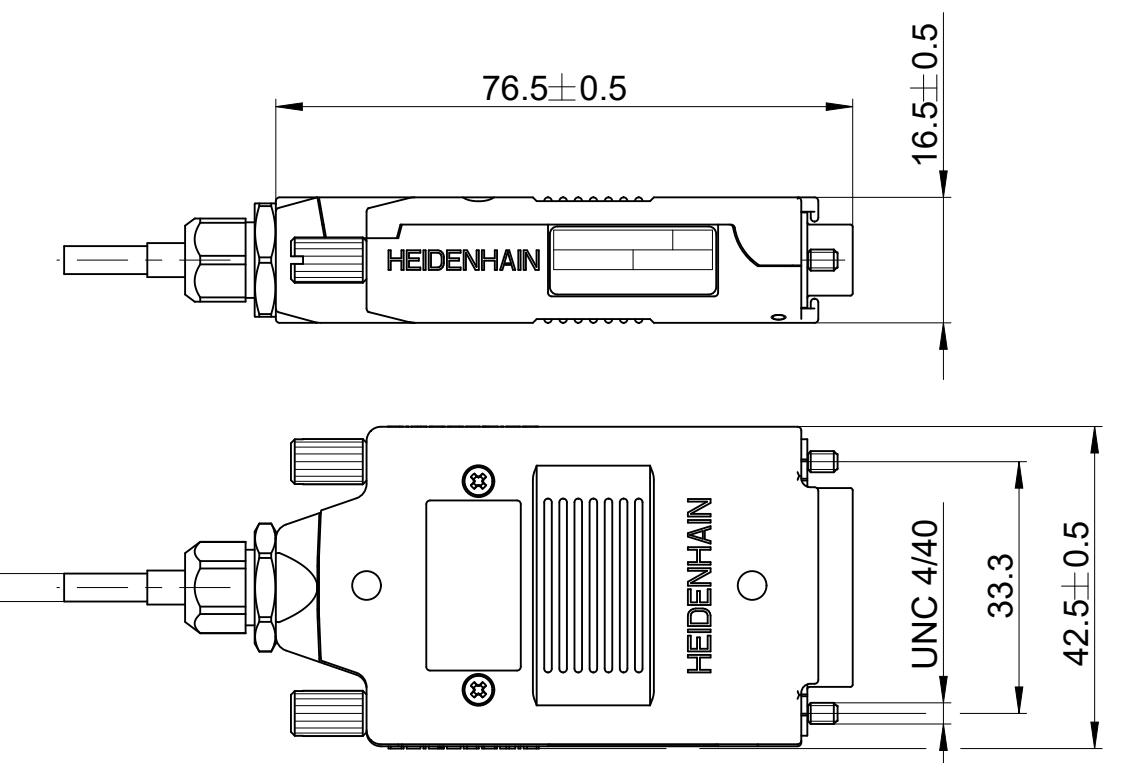
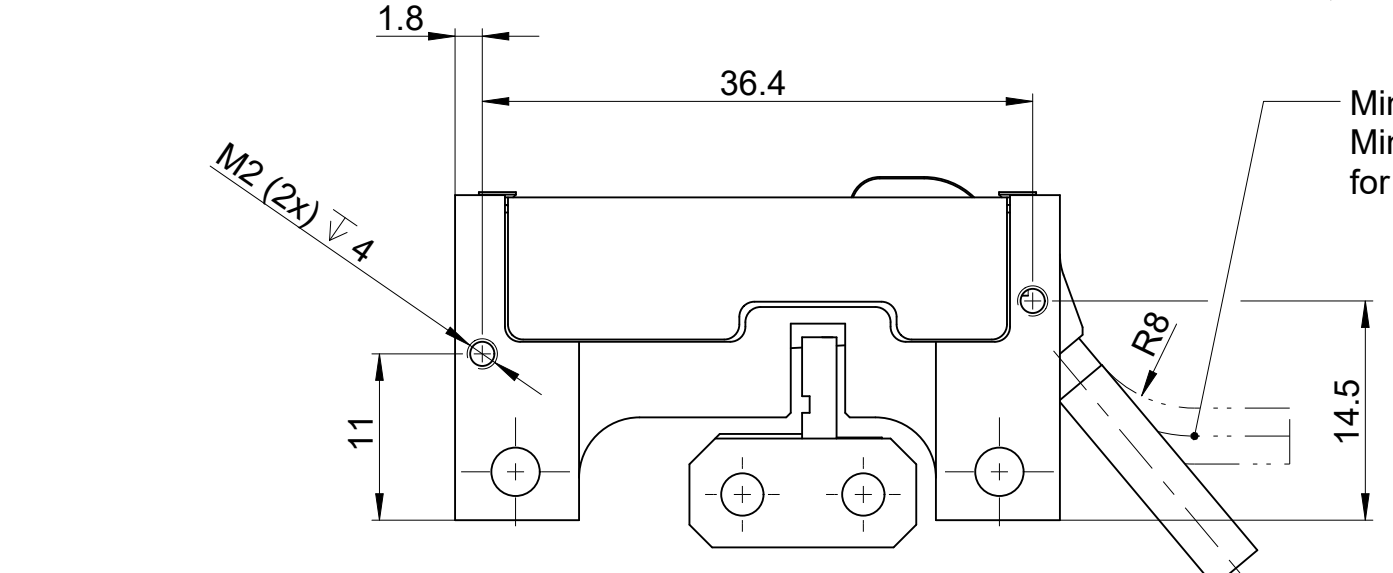
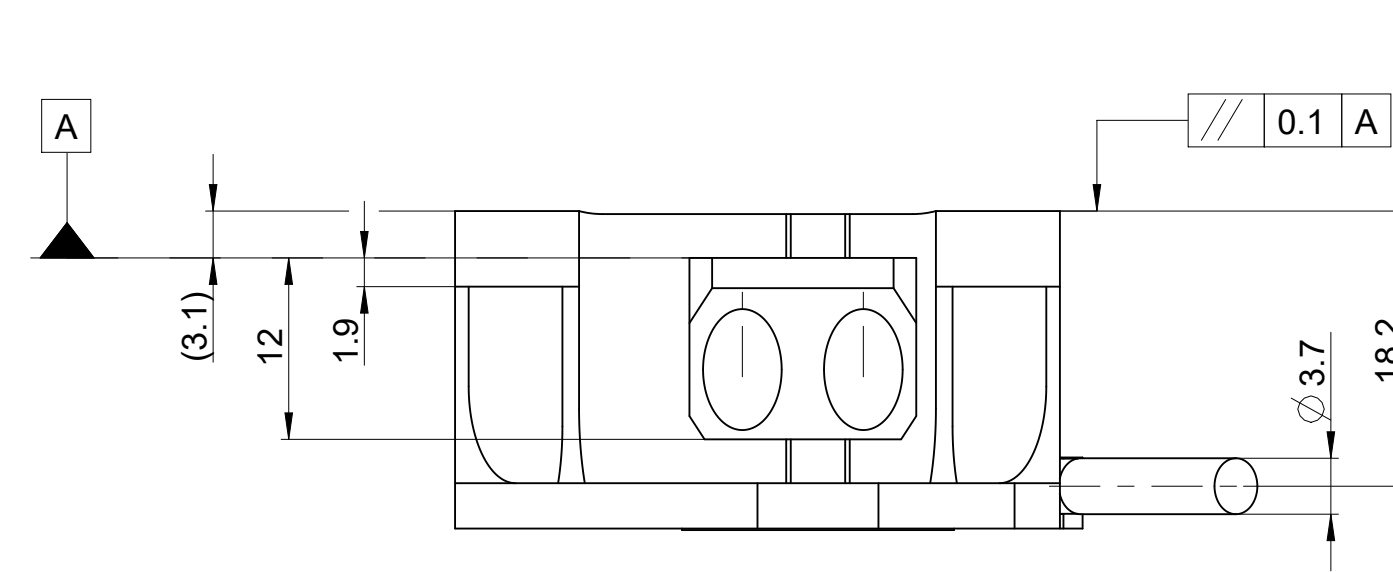
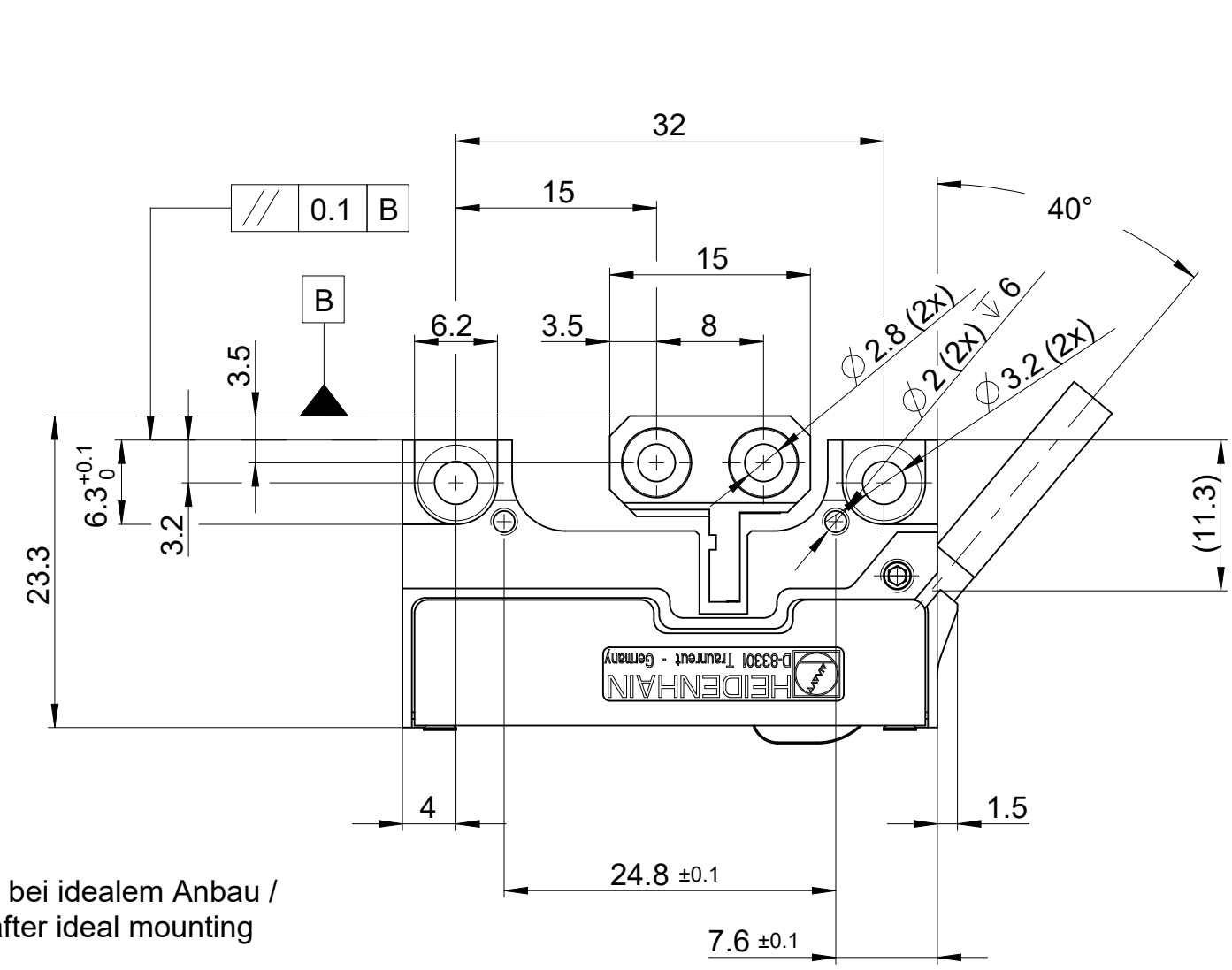
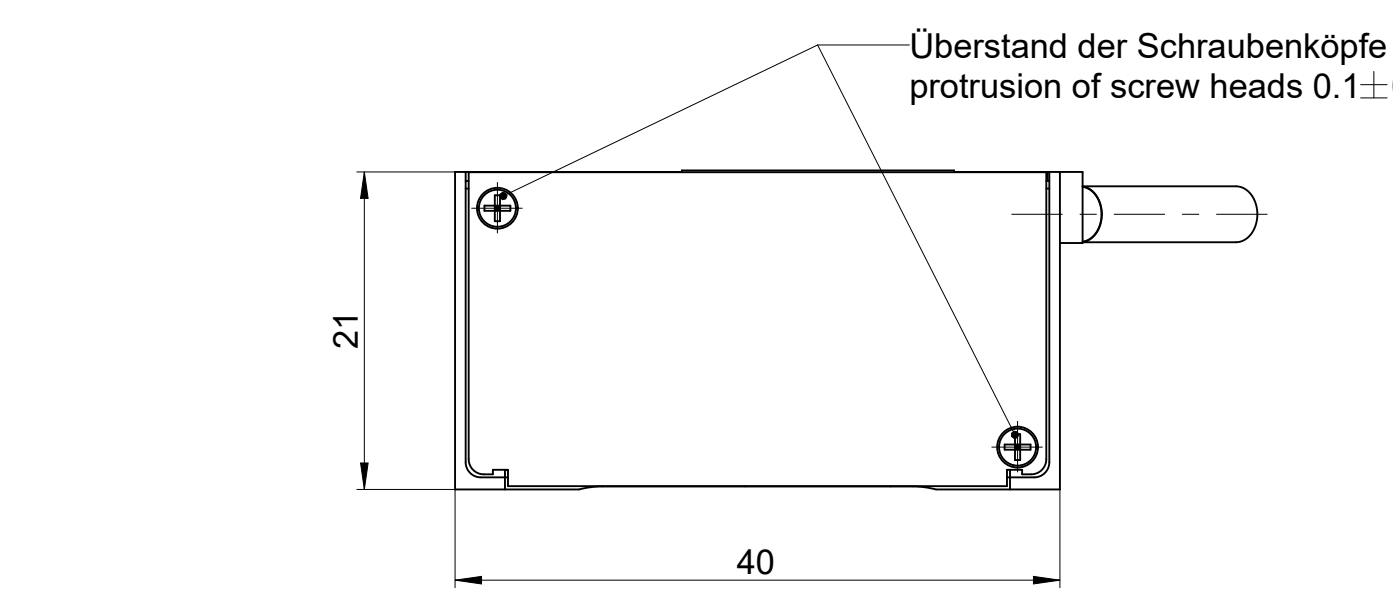
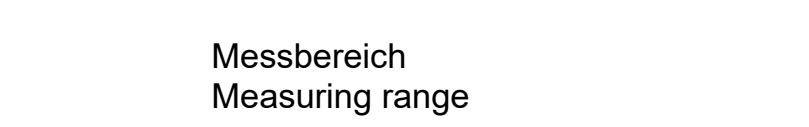
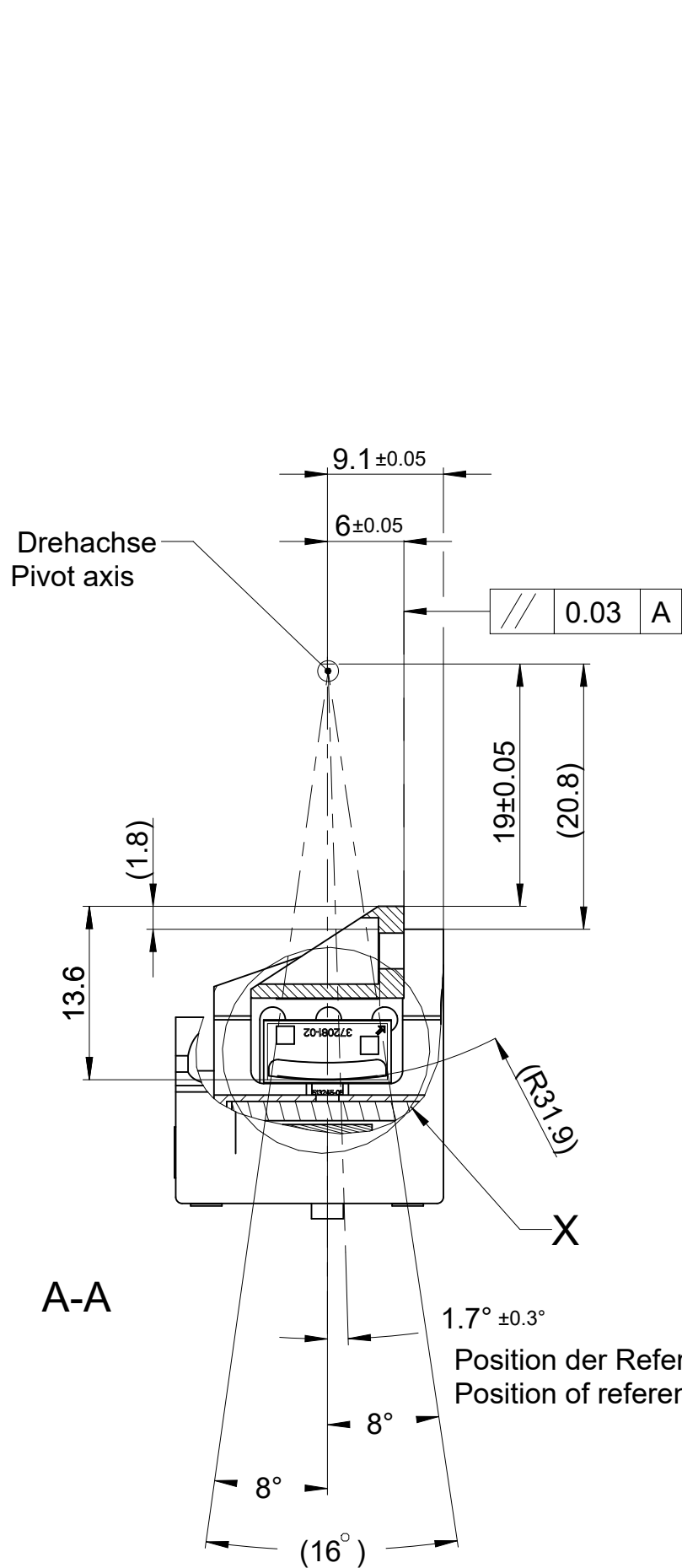

Original drawing		ID number: 663279-01	
Scale		Change No. C128994-12	
Format		Phase: Serie	
Dimensions in mm		Tolerierung nach DIN ISO 8015 Tolerances as per DIN ISO 8015	
2:1		Allgemeintol. ISO 2768-mH ±0.2 General tol. ISO 2768-mH ±0.2	
A2		Anschlussmaße / Mating Dimensions	
The reproduction, distribution and utilization of this document as well as the communication of its contents to others without express authorization is prohibited. Offenders will be held liable for the payment of damages. All rights reserved in the event of the grant of a patent, utility model or design. (ISO 16016)			
HEIDENHAIN DR. JOHANNES HEIDENHAIN GmbH 83301 Traunreut, Germany		Version Revision Sheet Page D 663279-02-A-01 1 1	
Document number		1 of 1	

896 200 A2

02

1 2 3 4 5 6 7 8