

# HEIDENHAIN

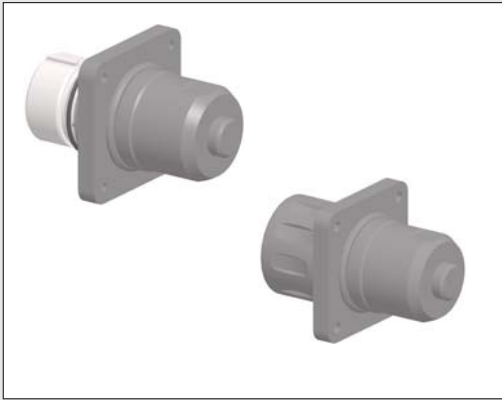

Montageanleitung  
*Mounting Instructions*  
Instructions de montage  
*Istruzioni di montaggio*  
Instrucciones de montaje

**Kupplung/Stecker M23 mit Flansch für 4x M3**  
***M23 coupling/connector with flange for 4x M3***  
**Prise d'accouplement/prise M23 avec bride pour 4x M3**  
***Connettore M23 con flangia 4x M3***  
**Acoplamiento/Conector M23 con brida para 4 x M3**

5/2008

**DR. JOHANNES HEIDENHAIN GmbH**

Dr.-Johannes-Heidenhain-Straße 5

**83301 Traunreut, Germany**

☎ +49 (8669) 31-0

FAX +49 (8669) 5061

E-Mail: [info@heidenhain.de](mailto:info@heidenhain.de)

**Technical support** FAX +49 (8669) 32-1000

**Measuring systems** ☎ +49 (8669) 31-3104

E-Mail: [service.ms-support@heidenhain.de](mailto:service.ms-support@heidenhain.de)

**TNC support** ☎ +49 (8669) 31-3101

E-Mail: [service.nc-support@heidenhain.de](mailto:service.nc-support@heidenhain.de)

**NC programming** ☎ +49 (8669) 31-3103

E-Mail: [service.nc-pgm@heidenhain.de](mailto:service.nc-pgm@heidenhain.de)

**PLC programming** ☎ +49 (8669) 31-3102

E-Mail: [service.plc@heidenhain.de](mailto:service.plc@heidenhain.de)

**Lathe controls** ☎ +49 (8669) 31-3105

E-Mail: [service.lathe-support@heidenhain.de](mailto:service.lathe-support@heidenhain.de)

**[www.heidenhain.de](http://www.heidenhain.de)**



Ve 00

650 703-91 · 3 · 5/2008 · H · Printed in Germany · Änderungen vorbehalten

*Subject to change without notice · Sous réserve de modifications · Con riserva di modifiche · Sujeto a modificaciones*

