



# HEIDENHAIN

Montageanleitung  
*Mounting Instructions*  
Instructions de montage  
*Istruzioni di montaggio*  
Instrucciones de montaje

## **Abtastkopf**

(für Sperrluftanwendung)

## **Scanning Head**

(for use of sealing air)

## **Tête caprice**

(pour utilisation de pressurisation)

## **Testina di scansione**

(per applicazioni con carter)

## **Cabezal captador**

(para aplicación de aire de estanqueidad)

# AK ERA 4x70/4x80

3/2010

**Inhalt · Contents · Sommaire · Indice · Indice**

**Maße in mm**  
**Dimensions in mm**  
**Cotes en mm**  
**Dimensioni in mm**  
**Dimensiones en mm**

Allgemeine Warnhinweise  
*General warning notes*  
Consignes générales  
*Avvertenze generali*  
Advertencias generales

4, 6 ←  → 5, 7

Abmessungen  
*Dimensions*  
Dimensions  
*Dimensioni*  
Dimensiones

8 ←  → 9

Anbau Teilungstrommel  
*Mounting the scale drum*  
Montage du tambour gradué  
*Montaggio del tamburo*  
Montaje del tambor graduado

10 ← 

Anbau AK  
*Mounting the scanning head*  
Montage de la tête caprice  
*Montaggio della testina di scansione*  
Montaje cabezal

12 ←  → 11, 13

Prüfung der Ausgangssignale  
*Checking the output signals*  
Contrôle des signaux de sortie  
*Verifica dei segnali in uscita*  
Comprobación de las señales de salida

14, 16 ←  → 15

Reinigungshinweise  
*Cleaning Instructions*  
Instructions de nettoyage  
*Istruzioni per la pulizia*  
Instrucciones de limpieza

 → 17

Verwendung von Druckluft  
*Use of compressed air*  
Utilisation d'air comprimé  
*Pressurizzazione*  
Utilización de aire comprimido

18 ←  → 19

Elektrische und Technische Kennwerte  
*Electrical data and technical specifications*  
Caractéristiques électriques et techniques  
*Dati elettrici e tecnici*  
Datos eléctricos y técnicos

20, 22, 24, 26 ←  → 21, 23, 25, 27



DIN EN 61340-5-1  
DIN EN 61340-5-2

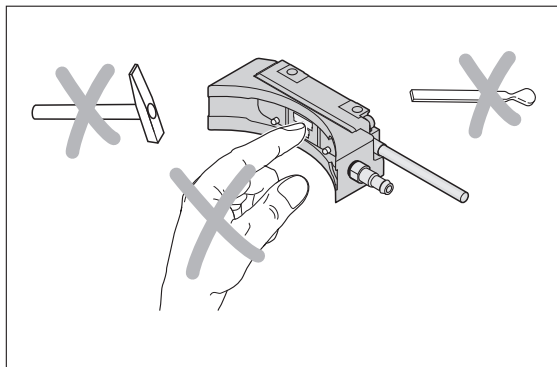
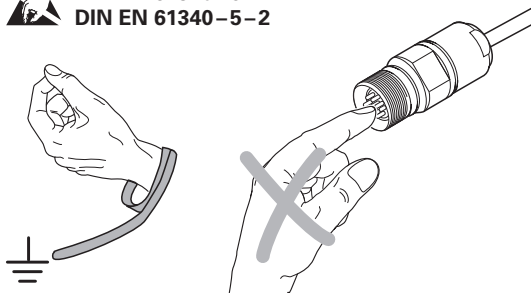

Der direkte Kontakt von Flüssigkeiten mit Messgerät und Steckverbinder ist zu vermeiden!

*Avoid direct contact of fluids with the encoder and connector!*

Eviter le contact direct de liquides sur le système de mesure et le connecteur!

*Evitare che il sistema di misura e il connettore vengano a contatto con liquidi.*

¡Evitar el contacto directo de líquidos con el sistema de medida y el conector!

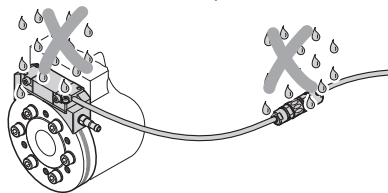



**Achtung:** Die Montage und Inbetriebnahme ist von einer Fachkraft für Elektrik und Feinmechanik unter Beachtung der örtlichen Sicherheitsvorschriften vorzunehmen.

Die Steckverbindung darf nur spannungsfrei verbunden oder gelöst werden.

Bei der Montage von AK und Teilungstrommel auch Maße und Hinweise der Montageanleitung der entsprechenden Teilungstrommel ERA 4x0x beachten.

Alle Montageflächen müssen gratfrei und sauber sein.

Angegebene Wellentoleranzen müssen eingehalten werden.

Die Teilungstrommel ist mit allen vorgesehenen Schrauben und Scheiben zu befestigen.

Die Schrauben sind entsprechend der Montageanleitung mit dem angegebenen Anzugsdrehmoment festzuschrauben und gegen unbeabsichtigtes Lösen zu sichern.

Nur dann gelten die für die Teilungstrommeln spezifizierten Drehzahlwerte.

**Note:** *Mounting and commissioning is to be conducted by a specialist in electrical equipment and precision mechanics under compliance with local safety regulations.*

*Do not engage or disengage any connections while under power.*

*When mounting the scanning head and the scale drum, please refer to the dimensions and notes in the Mounting Instructions for the respective ERA 4x0x Scale Drum.*

*All mounting surfaces must be clean and free of burrs.*

*The specified shaft tolerances must be complied with.*

*The scale drum is to be fastened with all provided screws and washers.*

*The screws must be tightened with the specified tightening torque according to the Mounting Instructions, and secured against unintentional loosening.*

*Only then are the speed values specified for the scale drums valid.*



**Attention:** Le montage et la mise en service doivent être réalisés par une personne qualifiée en électricité et mécanique de précision dans le respect des règles de sécurité locales.

Le connecteur ne doit être branché ou débranché que hors tension.

Lors du montage de la tête caprice et du tambour gradué, tenir compte également des cotes et remarques des Instructions de montage du tambour gradué ERA 4x0x concerné.

Toutes les surfaces doivent être lisses et propres.

Les tolérances indiquées pour l'arbre doivent être respectées.

Le tambour gradué doit être fixé en utilisant toutes les vis et rondelles prévues à cet effet.

Il convient de serrer les vis conformément aux Instructions de montage en respectant le couple de serrage indiqué et de s'assurer qu'elles ne puissent pas se dévisser malencontreusement.

Les valeurs de vitesse de rotation spécifiées pour les tambours gradués ne sont valables qu'à ces conditions.

**Attenzione:** *far eseguire montaggio e messa in servizio da un tecnico specializzato in impianti elettrici e meccanica di precisione in ottemperanza alle disposizioni di sicurezza locali.*

*Collegare o staccare i collegamenti soltanto in assenza di tensione.*

*Per il montaggio della testina e del tamburo, attenersi anche alle dimensioni e alle indicazioni riportate sulle istruzioni di montaggio del corrispondente tamburo ERA 4x0x. Le superfici di montaggio devono essere prive di graffi e pulite. Devono essere rispettate le tolleranze dell'albero indicate.*

*Il tamburo deve essere fissato con tutte le viti e le rondelle previste.*

*Le viti devono essere serrate alla coppia indicata nelle Istruzioni di montaggio e fissate contro l'allentamento involontario.*

*Solo in tali condizioni sono validi i valori di velocità specificati dei tamburi.*



**Atención:** El montaje y la puesta en marcha deben ser realizados por un especialista en electricidad y mecánica de precisión, observando las prescripciones locales de seguridad.

Conectar o desconectar el conector sólo en ausencia de tensión.

Durante el montaje del cabezal captador AK y del tambor graduado prestar atención también a las medidas e indicaciones de las Instrucciones de Montaje del correspondiente tambor graduado ERA 4x0x.

Todas las superficies de montaje deben estar sin rebabas y limpias. Deben respetarse las tolerancias de eje indicadas. El tambor graduado debe fijarse con todos los tornillos y arandelas previstos.

Los tornillos deben apretarse según las Instrucciones de Montaje con el par de apriete indicado y asegurarse para que no se aflojen involuntariamente.

Sólo entonces son válidos los valores de velocidad especificados para los tambores graduados.





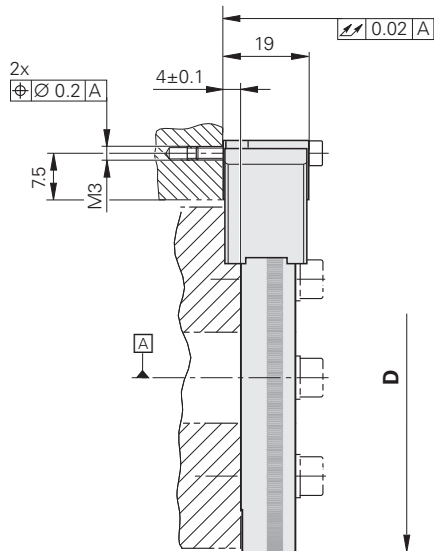

[A] = Lagerung  
 Bearing  
 Roulement  
 Cuscinetto  
 Rodamiento

(+1) = Montageabstand mit Abstandsfolie eingestellt  
 Mounting clearance set with spacer foil  
 Distance fonctionnelle réglée avec cale d'épaisseur  
 Distanza di montaggio definita con pellicola  
 Distancia de montaje fijada mediante lámina espaciadora

(+2) = Anschlussstück für Kunststoff-Druckschlauch 6 x 1 mm  
 Connecting piece for plastic pressure tubing 6 x 1 mm  
 Raccord pour tuyau de pression PVC 6 x 1 mm  
 Raccordo per tubo flessibile in plastica 6 x 1 mm  
 Racor de conexión para manguera de presión de plástico 6 x 1 mm

**Montage der Teilungstrommel siehe Montageanleitung für die Teilungstrommel ERA 4x0x.**  
***For mounting of the scale drum, refer to the Mounting Instructions for ERA 4x0x scale drum.***  
**Montage du tambour gradué, cf. Instructions de montage pour les tambours gradués ERA 4x0x.**  
***Montaggio del tamburo vedere le Istruzioni di montaggio del tamburo ERA 4x0x.***  
**Montaje del tambor graduado, ver Instrucciones de Montaje para el tambor graduado ERA 4x0x.**

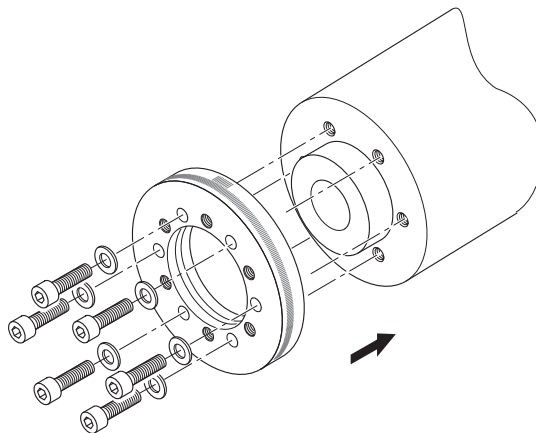

Bei Verwendung einer Sperrluftabdeckung ist der Sperrluftanschluss des AK vor dem Anbau zu entfernen!  
Empfehlung: Maulschlüssel zum Gegenhalten verwenden.

*If a protective cover is to be used, the sealing air inlet of the scanning head must be removed before mounting.  
Recommendation: Brace the scanning head with an open-end wrench.*

Si l'on utilise un boîtier pressurisé, retirer le raccordement de pressurisation de la tête caprice avant le montage!  
Conseil: utiliser une clé plate pour le contre serrage.

*In caso di impiego di un carter di protezione è necessario rimuovere il raccordo di pressurizzazione della testina prima di procedere al montaggio! Suggerimento: utilizzare una chiave inglese come antirotazione.*

¡Al utilizar una cubierta de aire de estanqueidad debe retirarse la conexión de aire del cabezal antes del montaje!  
Recomendación: utilizar la llave fija para retener.

Maulschlüssel darf nicht überstehen

*Open-end wrench may not protrude*

La clé plate ne doit pas dépasser

*La chiave non deve oltrepassare la sagoma*

La llave fija no puede sobresalir



**falsch**  
**Incorrect**  
**incorrect**  
**errato**  
**incorrecto**

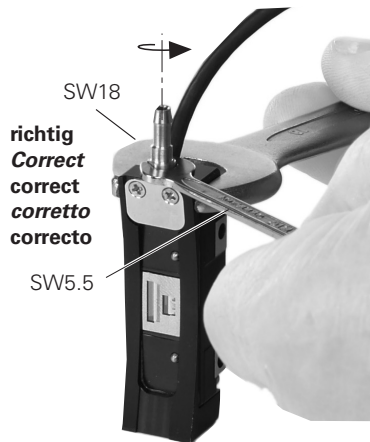
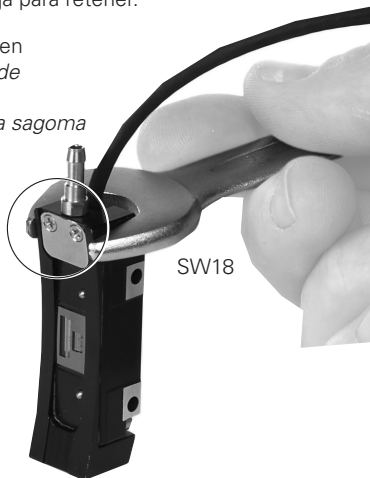

**richtig**  
**Correct**  
**correct**  
**corretto**  
**correcto**

**1.**

Schutzkappe entfernen (wenn vorhanden).  
*Remove the protective cover (if applicable).*  
Retirer le capuchon de protection (si présent).  
*Rimuovere la protezione (se presente).*  
Retirar la tapa protectora (si existe).

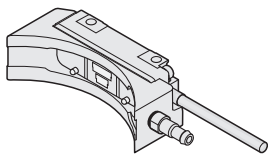

**2.**

ISO 4762-A2-M3x25

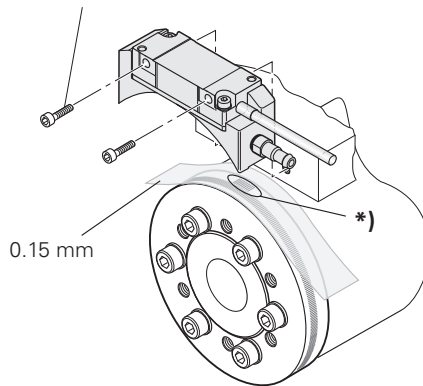

**\*)** Auf die Lage der Referenzmarkenspur achten!  
*Ensure correct position of reference mark track!*  
Veiller à la position de la piste de marque de référence!  
*Attenzione alla posizione della traccia degli indici di riferimento!*  
Tener en cuenta la posición de la pista de marcas de referencia!

3.

2x  
 $M_d = 1.15 \text{ Nm}$

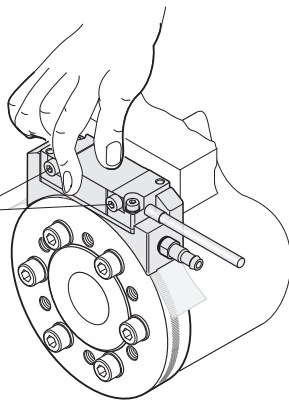

4.

oder, or, ou, o, o

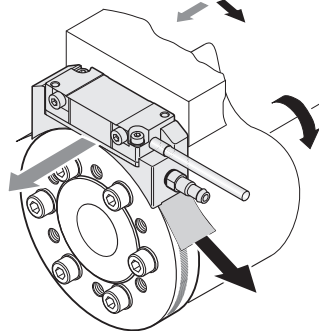

Abtastkopf mit geringer Kraft gegen die Abstandsfolie und Anschraubfläche drücken und festschrauben.  
*Gently press the scanning head against the spacer foil and the mounting surface and secure it with the screws provided.*  
Presser légèrement la tête caprice contre la cale d'épaisseur et la surface de vissage et serrer les vis.  
*Premere la testina di scansione esercitando una leggera pressione sulla pellicola di montaggio e sulla superficie di avvitamento e fissare.*  
Presionar el cabezal captador suavemente contra la lámina separadora y la superficie de atornillamiento, y atornillar.

**Prüfung der Ausgangssignale**  
**Checking the output signals**  
**Contrôle des signaux de sortie**  
**Verifica dei segnali in uscita**  
**Comprobación de las señales de salida**

siehe Betriebsanleitung PWT 1x, ID 319 502-9x.  
*see Operating Instructions for PWT 1x, ID 319 502-9x.*  
cf. également Mode d'emploi PWT 1x, ID 319 502-9x.  
*vedi Manuale di istruzioni del PWT 1x, ID 319 502-9x.*  
ver también las Modo de empleo del PWT 1x, ID 319 502-9x.

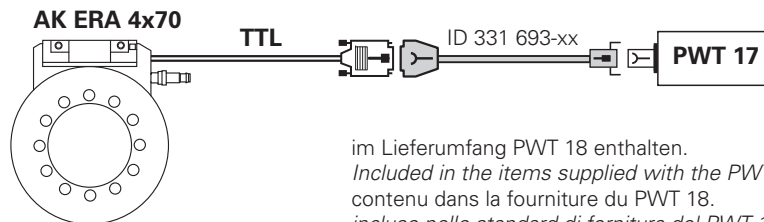

im Lieferumfang PWT 18 enthalten.  
*Included in the items supplied with the PWT 18.*  
contenu dans la fourniture du PWT 18.  
*incluso nello standard di fornitura del PWT 18.*  
incluido en los elementos suministrados del PWT 18.

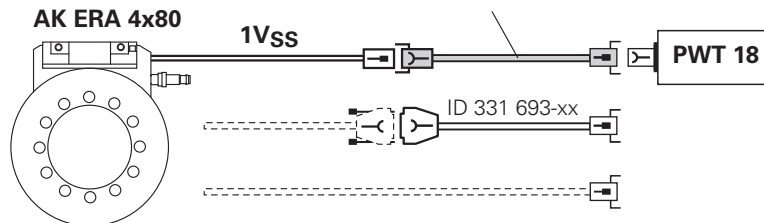

Mit dem PWT kann Signalamplitude, Signalqualität, Lage und Breite der Referenzmarke angezeigt werden.  
*The PWT shows the signal amplitude, signal quality, position and width of the reference mark in a display window.*  
 Le PWT permet d'afficher l'amplitude et la qualité du signal, la position et la largeur de la marque de référence.  
*Il PWT consente di visualizzare ampiezza del segnale, qualità del segnale, posizione e larghezza dell'indice di riferimento.*  
 Con el PWT pueden visualizarse la amplitud y calidad de la señal, y la posición y anchura de la marca de referencia.

Signalamplitude	Signalqualität
<i>Signal amplitude</i>	<i>Signal quality</i>
Amplitude du signal	Qualité du signal
<i>Ampiezza del segnale</i>	<i>Qualità del segnale</i>
amplitud de la señal	calidad de la señal

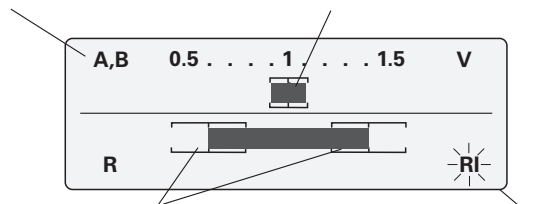

Toleranz des Nulldurchganges der Referenzmarke  
*Tolerance of zero crossover of the reference mark*  
 Tolérance du passage à zéro de la marque de référence  
*Tolleranza del cross-over dell'indice di riferimento*  
 Tolerancia del paso por cero de la marca de referencia

Messung ist älter als 15 sek.  
*Measurement is older than 15 seconds*  
 Mesure antérieure à 15 sec.  
*Misurazione eseguita da più di 15 sec.*  
 Medición anterior a 15 seg.

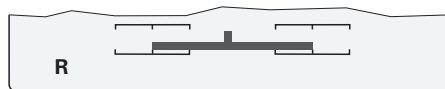

Messung der Referenzmarke  
*Reference mark measurement*  
 Mesure marque de référence  
*Misurazione dell'indice di riferimento*  
 Medición marca de referencia

Können die angegebenen Signalwerte nicht erreicht werden, Anbautoleranzen überprüfen und Reinigungshinweise beachten.

*If the given signal values cannot be achieved, check the mounting tolerances or refer to the cleaning instructions.*

Si les valeurs indiquées pour les signaux ne peuvent pas être atteintes, vérifiez les tolérances de montage et les instructions de nettoyage.

*Nel caso non possano essere ottenuti i valori di taratura indicati, controllare le tolleranze di montaggio e attenersi alle istruzioni per la pulizia.*

Si no se pueden alcanzar los valores de señal indicados, comprobar las tolerancias de montaje y prestar atención a las instrucciones de limpieza.

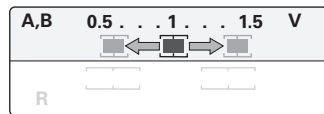
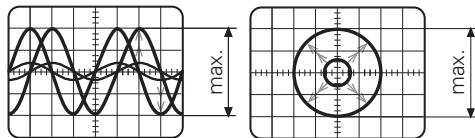

PWT 18 A,B  $1 \pm 0.2 \text{ V}$

PWT 17  $I_{1,2} 11 \pm 2 \mu\text{A}$

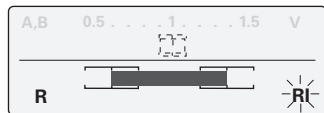

OK ✓

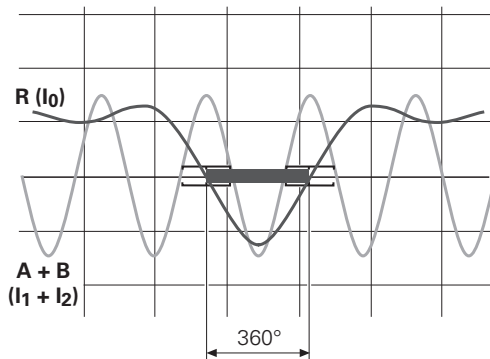



**Reinigungshinweise**  
**Cleaning Instructions**  
**Instructions de nettoyage**  
**Istruzioni per la pulizia**  
**Instrucciones de limpieza**

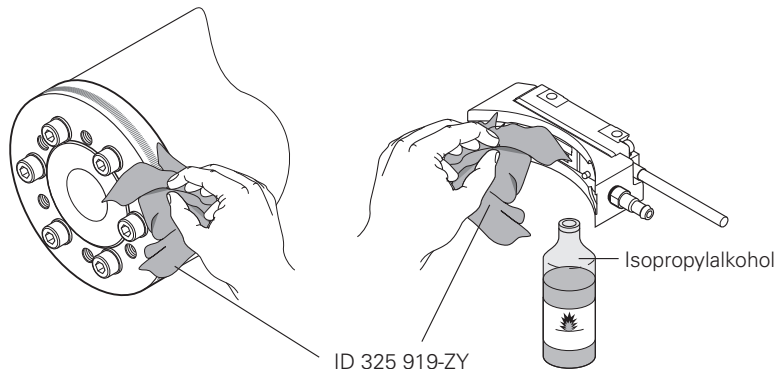

Bei verschmutztem Abtastkopf oder Teilungstrommel Meßgerät mit sauberem fusselfreiem Tuch und Isopropylalkohol vorsichtig reinigen. Feste Partikeln vorher mit Druckluft abblasen.

*If the scanning head or scale drum is contaminated, carefully clean the encoder with a clean, lint-free cloth and isopropyl alcohol. Remove solid particles with a jet of compressed air first.*

Si la tête caprice ou le tambour gradué est sale, nettoyer avec précaution le système de mesure à l'aide d'un chiffon non pelucheux et d'isopropanol. Evacuer auparavant les particules solides à l'aide d'air comprimé.

*Con testina di scansione o tamburo contaminato pulire con cura il sistema di misura utilizzando un panno pulito che non lascia pelucchi e isopropanolo. Prima rimuovere lo sporco più consistente con l'aria compressa.*

En caso de suciedad en el cabezal captador o en el tambor graduado, limpiar cuidadosamente el sistema de medida con un paño limpio libre de pelusa e isopropanol. Quitar antes las partículas sólidas soplando con aire comprimido.

Die in das Messgerät eingeleitete Druckluft muss durch eine Druckluftaufbereitung gereinigt sein und folgenden Qualitätsklassen nach **ISO 8573-1** (Ausgabe 1995) entsprechen:

- feste Verunreinigungen: Klasse 1 (max. Teilchengröße 0.1  $\mu\text{m}$  und max. Teilchendichte 0.1  $\text{mg}/\text{m}^3$  bei  $1 \cdot 10^5$  Pa).
- Gesamt-Ölgehalt: Klasse 1 (max. Ölkonzentration 0.01  $\text{mg}/\text{m}^3$  bei  $1 \cdot 10^5$  Pa).
- max. Drucktaupunkt: Klasse 4, jedoch bei Referenzbedingungen +3 °C bei  $2 \cdot 10^5$  Pa.

*The compressed air introduced directly into the encoder must be appropriately conditioned, and must comply with the following quality classes as per **ISO 8573-1** (1995 Edition):*

- *Solid contaminants: Class 1 (max. particle size 0.1  $\mu\text{m}$  and max. particle density 0.1  $\text{mg}/\text{m}^3$  at  $1 \cdot 10^5$  Pa).*
- *Total oil content: Class 1 (max. oil concentration 0.01  $\text{mg}/\text{m}^3$  at  $1 \cdot 10^5$  Pa.*
- *Max. pressure dew point: Class 4, but with reference conditions of +3 °C at  $2 \cdot 10^5$  Pa.*

L'air comprimé injecté dans le système de mesure doit être purifié de manière appropriée et être conforme aux normes de qualité selon **ISO 8573-1** (édition 1995):

- Impuretés solides: Classe 1 (taille max. des particules 0.1  $\mu\text{m}$  et densité max. des particules 0.1  $\text{mg}/\text{m}^3$  à  $1 \cdot 10^5$  Pa).
- Teneur totale en huile: Classe 1 (concentration max. en huile 0.01  $\text{mg}/\text{m}^3$  à  $1 \cdot 10^5$  Pa).
- Point de condensation de pression max.: Classe 4 mais en conditions de référence +3 °C à  $2 \cdot 10^5$  Pa.

*L'aria compressa convogliata direttamente nel sistema di misura deve essere purificata con un apposito sistema di preparazione e conforme alle seguenti classi di qualità a norma **ISO 8573-1** (edizione 1995):*

- *impurità solide: classe 1 (dimensione max particelle 0,1  $\mu\text{m}$  e densità max particelle 0,1  $\text{mg}/\text{m}^3$  con  $1 \cdot 10^5$  Pa).*
- *volume di olio complessivo: classe 1 (concentrazione olio max 0,01  $\text{mg}/\text{m}^3$  con  $1 \cdot 10^5$  Pa).*
- *punto di rugiada max: classe 4, ma con condizioni di riferimento +3 °C con  $2 \cdot 10^5$  Pa.*

El aire comprimido introducido directamente en el sistema de medida debe haberse limpiado mediante un dispositivo de aire correspondiente, y debe corresponder a los siguientes tipos de calidad según **ISO 8573-1** (edición 1995):

- Impurezas sólidas: Clase 1 (tamaño máx. de partícula 0,1  $\mu\text{m}$  y densidad máx. de partícula 0,1  $\text{mg}/\text{m}^3$  a  $1 \times 10^5$  Pa).
- Contenido total de aceite: Clase 1 (concentración máx. de aceite 0,01  $\text{mg}/\text{m}^3$  a  $1 \times 10^5$  Pa).
- Punto máx. de rocío de presión: Clase 4, no obstante a condiciones de referencia +3 °C a  $2 \times 10^5$  Pa.

HEIDENHAIN bietet zur Reinigung der Druckluft die Druckluftanlage DA 300 an.  
*HEIDENHAIN offers the DA 300 Compressed Air Unit for purifying compressed air.*  
Pour nettoyer l'air comprimé, HEIDENHAIN propose le dispositif de pressurisation DA 300.  
*HEIDENHAIN offre per il trattamento dell'aria compressa l'impianto di pressurizzazione DA 300.*  
HEIDENHAIN ofrece el dispositivo de aire comprimido DA 300 para la limpieza del aire.

## DA 300

ID 348 249-01

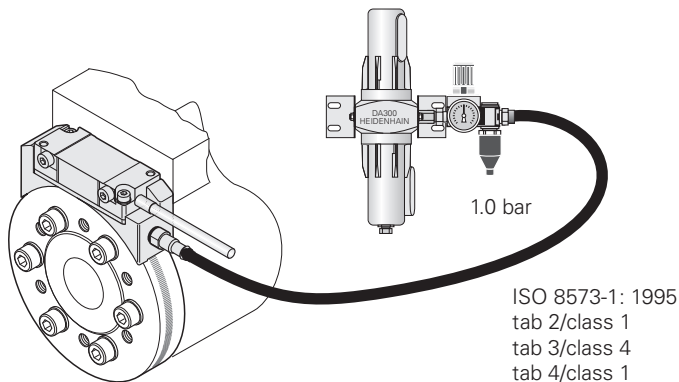

# ERA 4x70

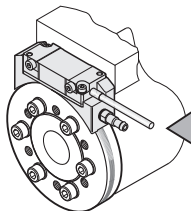

$U_p = 5V \pm 10\%$   
(max. 200 mA)

EN 50178  
PELV  $\frac{1}{2}$  EN 60204-1

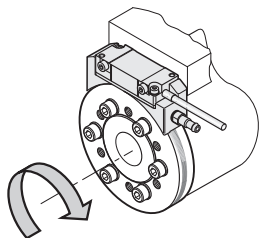

**TTL**

$U_{a1}, U_{a2}, U_{a0}$   
 $\overline{U_{a1}}, \overline{U_{a2}}, \overline{U_{a0}}, \overline{U_{aS}}$

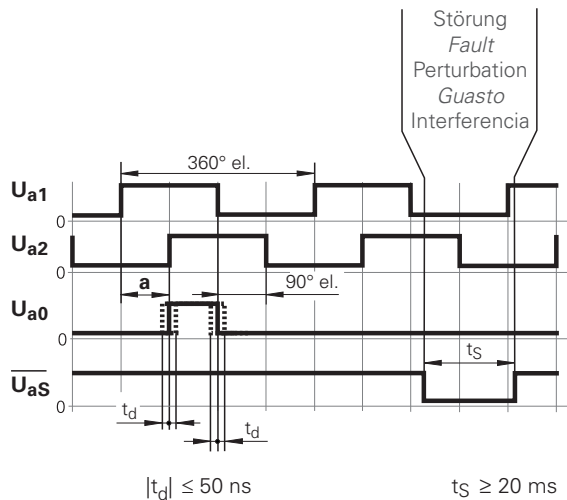

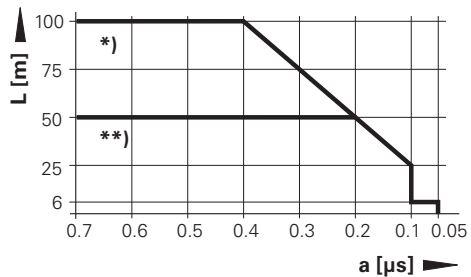
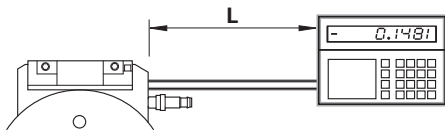

$\overline{U_{aS}}$ : Störungssignal  
*Fault detection signal*  
 Signal de perturbation  
 Segnale di guasto  
 Señal de avería

$\overline{U_{aS}} = \text{High}$ : ✓

$\overline{U_{aS}} = \text{Low}$ :

\*) ohne  
*without*  
 sans  
 senza  
 sin }  $\overline{U_{aS}}$

\*\*) mit  
*with*  
 avec  
 con  
 con }  $\overline{U_{aS}}$

## ERA 4x70



93S15-3K

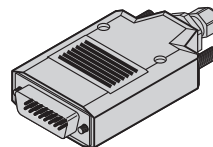
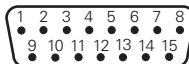

- 1) Im Normalbetrieb mit 0 V der Folgeelektronik verbinden.

Bei Anlegen von 5 V Umschaltung TTL/11  $\mu$ Ass.

*In normal operation, connect with the 0 V line of the subsequent electronics.*

*Apply 5 V and switch to TTL/11  $\mu$ App.*

En fonctionnement normal, relier au 0 V de l'électronique consécutive.

Avec application de 5 V commutation TTL/11  $\mu$ ACC.

*In funzionamento normale collegare a 0 V dell'elettronica successiva.*

*Per applicare 5 V commutazione TTL/11  $\mu$ App.*

En funcionamiento normal conectar con 0 V de la electrónica subsiguiente.

Al aplicar 5 V conmutación TTL/11 $\mu$ App.

Schirm auf Gehäuse

*Shield on housing*

Blindage sur boîtier

*Schermo sulla carcassa*

Blindaje a carcasa

4	12	2	10	1	9	3	11	14	7	13	15	5, 6, 8
5 V	Sensor $U_P$	0 V	Sensor 0 V	$U_{a1}$	$\overline{U_{a1}}$	$U_{a2}$	$\overline{U_{a2}}$	$U_{a0}$	$\overline{U_{a0}}$	$\overline{U_{aS}}$	1)	/

Die Sensorleitung ist im Steckverbinder des Messgerätes mit der Versorgungsleitung verbunden.

*The sensor line is connected internally with the power supply.*

La ligne de palpeur est reliée de manière interne à la ligne d'alimentation.

*La linea del sensore è collegata internamente con la linea di alimentazione.*

La línea de sensor está unida internamente con la línea de alimentación.

## ERA 4x80

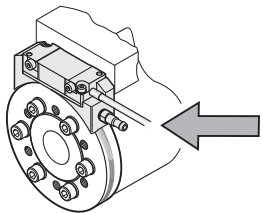

**U<sub>p</sub> = 5 V ± 10 %**  
(max. 100 mA)

EN 50 178  
PELV  $\perp$  EN 60204-1

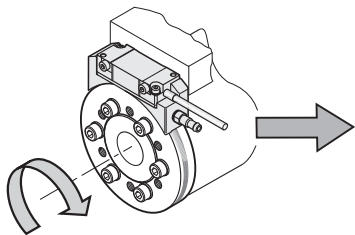

**A, B, R**

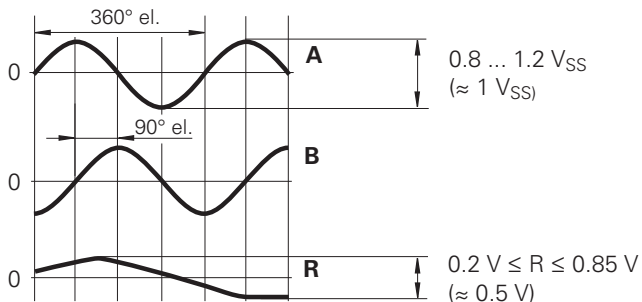

# ERA 4x80



01 -H2

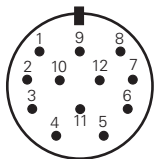
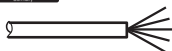

03S12-H2

35S12-H2

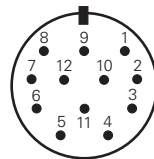
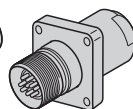
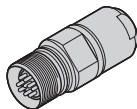

02S12-H2

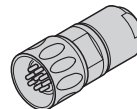

2	12	10	11	5	6	8	1	3	4	7	9	/	/
Up		0V		A+	A-	B+	B-	R+	R-	/	/	/	/
BNGN	WHGN	BN	GN	GY	PK	RD	BK	VT	YE	BU	WH		

Kabelschirm mit Gehäuse verbunden

*Cable shield connected to housing*

Blindage du câble relié au boîtier

*Collegare lo schermo del cavo alla carcassa*



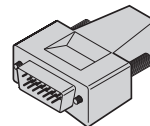
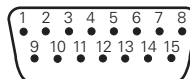

Pantalla del cable conectada a carcasa

16S15-H1

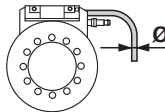

4	12	2	10	1	9	3	11	14	7	8	6	13	5	15
Up		0V		A+	A-	B+	B-	R+	R-	/	/	/	/	/
BNGN	WHGN	BN	GN	GY	PK	RD	BK	VT	YE	BU	WH	/		

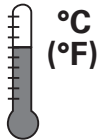
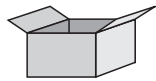

	 <p><math>T \geq -40\text{ °C}</math> (40 °F)</p>	 <p><math>T \geq -10\text{ °C}</math> (14 °F)</p>	  <p>-30 ... 80 °C (-22 ... 176 °F)</p>
<p><b>Ø 3.7 mm</b></p>	<p><math>R_1 \geq 8\text{ mm}</math></p>	<p><math>R_2 \geq 40\text{ mm}</math></p>	
<p><b>Ø 8 mm</b></p> 	<p><math>R_1 \geq 40\text{ mm}</math></p>	<p><math>R_2 \geq 100\text{ mm}</math></p>	

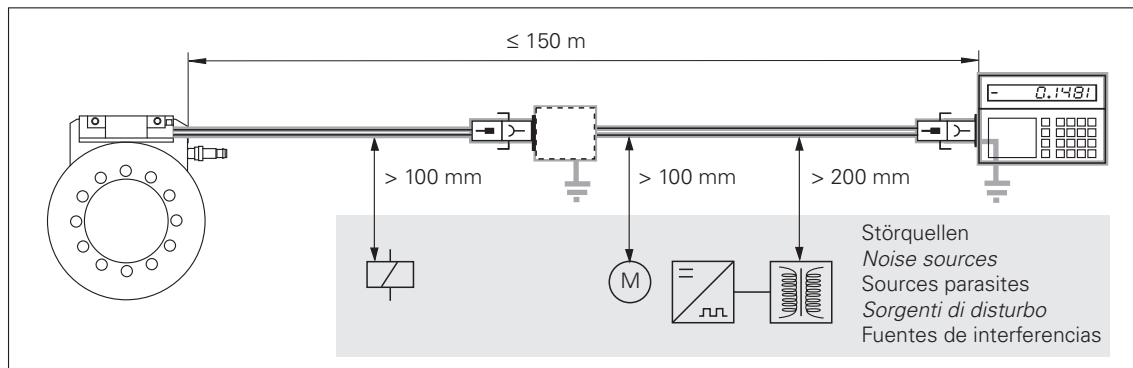

Elektrischen Widerstand zwischen Steckergehäuse und Maschine prüfen.

**Sollwert: < 1  $\Omega$ .**

*Check the resistance between the connector housing and the machine.*

**Desired value: < 1  $\Omega$ .**

Tester la résistance électrique entre le carter de la prise et la machine.

**Valeur nominale: < 1  $\Omega$ .**

*Controllare la resistenza elettrica tra l'alloggiamento del connettore e la macchina.*

**Valore nominale: < 1  $\Omega$ .**

Comprobar la resistencia eléctrica entre la carcasa del conector y la máquina.

**Valor nominal: < 1  $\Omega$ .**

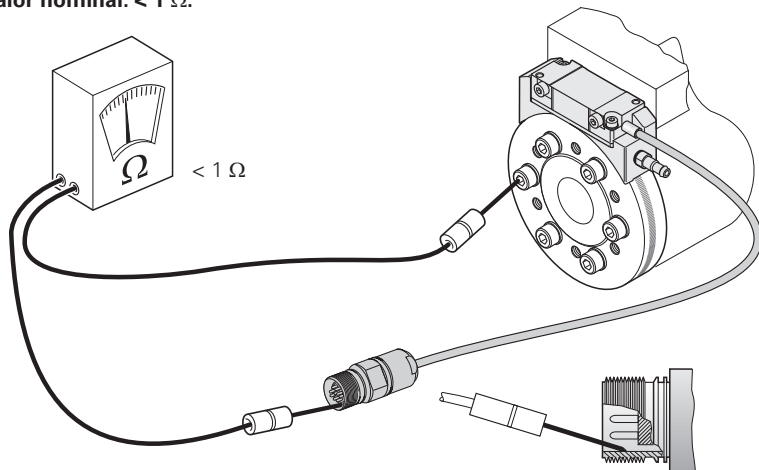



# HEIDENHAIN

---

## DR. JOHANNES HEIDENHAIN GmbH

Dr.-Johannes-Heidenhain-Straße 5

**83301 Traunreut, Germany**

☎ +49 8669 31-0

FAX +49 8669 5061

E-mail: [info@heidenhain.de](mailto:info@heidenhain.de)

---

**Technical support** FAX +49 8669 32-1000

**Measuring systems** ☎ +49 8669 31-3104

E-mail: [service.ms-support@heidenhain.de](mailto:service.ms-support@heidenhain.de)

**TNC support** ☎ +49 8669 31-3101

E-mail: [service.nc-support@heidenhain.de](mailto:service.nc-support@heidenhain.de)

**NC programming** ☎ +49 8669 31-3103

E-mail: [service.nc-pgm@heidenhain.de](mailto:service.nc-pgm@heidenhain.de)

**PLC programming** ☎ +49 8669 31-3102

E-mail: [service.plc@heidenhain.de](mailto:service.plc@heidenhain.de)

**Lathe controls** ☎ +49 8669 31-3105

E-mail: [service.lathe-support@heidenhain.de](mailto:service.lathe-support@heidenhain.de)

---

**[www.heidenhain.de](http://www.heidenhain.de)**

