

**Spannungsversorgung**  
**Power supply**  
**Tension d'alimentation**  
**Tensione di alimentazione**  
**Tensión de alimentación**

**Up: DC 5 V ± 0.5 V**  
 (am Gerät, at encoder, sur l'appareil, integrato, en el aparato).  
 I<sub>max.</sub> 120 mA  
 (ohne Last, Without load, sans charge, senza carico, sin carga).

**Ausgangssignale**  
**Output signals**  
**Signaux de sortie**  
**Segnali in uscita**  
**Señales de salida**

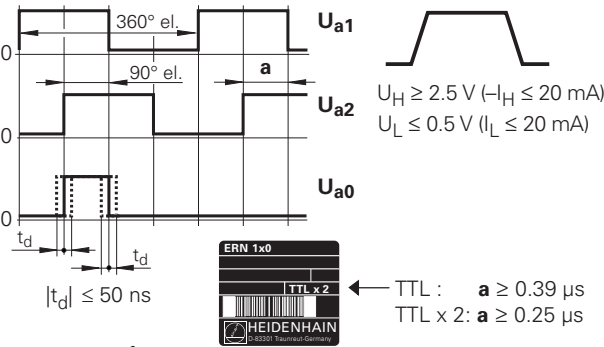
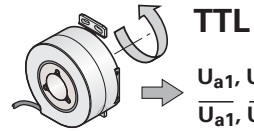

**UaS:** Störungssignal  
 Fault detection signal  
 Signal de perturbation  
 Segnale di malfunzionamento  
 Señal de avería

**UaS = High:** ✓  
**UaS = Low:** ⚠

**Achtung:** Die Steckverbindung darf nur spannungsfrei verbunden oder gelöst werden.  
**Note:** Do not engage or disengage any connections while under power.  
**Attention:** Le connecteur ne doit être branché ou débranché que hors tension.  
**Attenzione:** Collegare o staccare i collegamenti soltanto in assenza di tensione.  
**Atención:** Conectar o desconectar el conector sólo en ausencia de tensión.

Biegeradius **R**  
 Bending radius **R**  
 Rayon de courbure **R**  
 Piegatura **R**  
 Radio de curvatura **R**

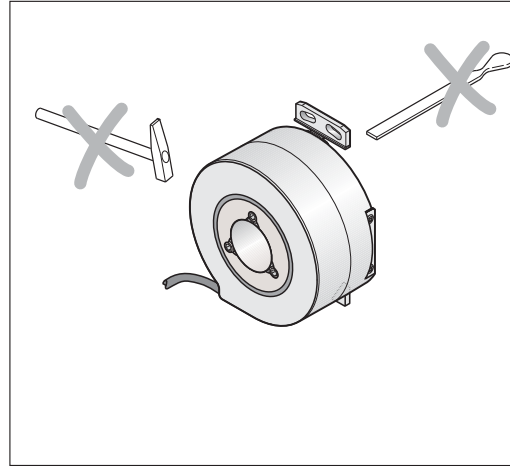
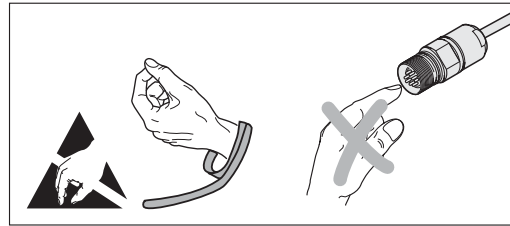
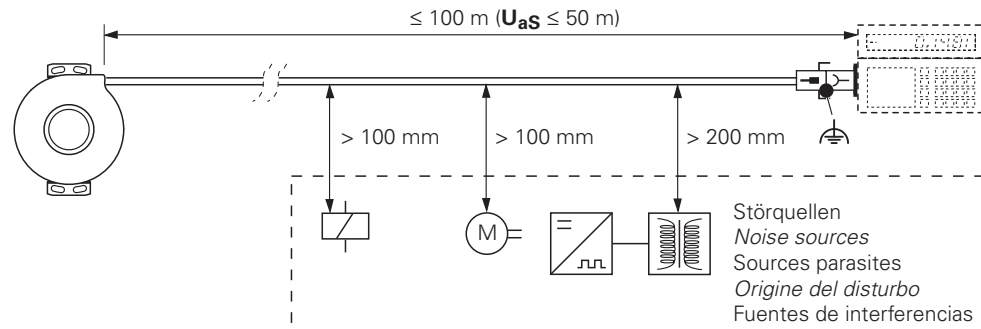
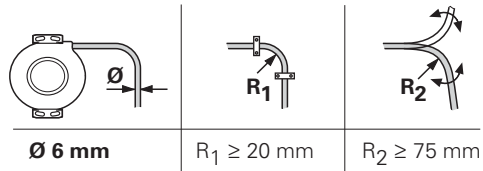

**HEIDENHAIN**

Montageanleitung  
 Mounting Instructions  
 Instructions de montage  
 Istruzioni di montaggio  
 Instrucciones de montaje

**ERN 120**

7/2017



**Achtung:** Die Montage und Inbetriebnahme ist von einer qualifizierten Fachkraft unter Beachtung der örtlichen Sicherheitsvorschriften vorzunehmen.

Zusätzlich muss der Maschinenhersteller/-konstrukteur die erforderlichen weiteren Angaben zur Endmontage (z.B. Losdrehicherung für Schrauben ja/nein) für die jeweilige Anwendung selbst festlegen.

**Note:** Mounting and commissioning is to be conducted by a qualified specialist under compliance with local safety regulations.

In addition to this, the machine manufacturer or designer himself must define the other data required for final assembly (e.g. anti-rotation lock for screws required or not) for the respective application.

**Attention:** le montage et la mise en service doivent être assurés par un personnel qualifié dans le respect des consignes de sécurité locales.

D'autre part, le fabricant/constructeur de la machine doit définir d'autres données nécessaires au montage final (p.ex. sécurité frein de vis oui/non) pour l'application respective.

**Attenzione:** Il montaggio e la messa in funzione devono essere eseguite da personale qualificato nel rispetto delle norme di sicurezza locali.

Inoltre, il costruttore della macchina deve definire le ulteriori procedure necessarie per completare il montaggio (ad esempio: sicurezza allentamento viti sì/no) di ogni specifica applicazione.

**Atención:** El montaje y la puesta en marcha deben ser realizados por un especialista cualificado, observando las prescripciones locales de seguridad.

Adicionalmente, el fabricante/constructor de la máquina debe determinar él mismo el resto de indicaciones requeridas para el montaje final para cada aplicación en particular (p.ej., seguro antigiro para tornillos sí/no).

**DR. JOHANNES HEIDENHAIN GmbH**

Technical support, measuring systems ☎ +49 8669 31-3104 · E-mail: service.ms-support@heidenhain.de

# ERN 120

**Kundenseitige Anschlussmaße (mm)**  
**Required mating dimensions (mm)**  
**Conditions requises pour le montage (mm)**  
**Quote per il montaggio (mm)**  
**Cotas de montaje requeridas (mm)**

Ⓜ = Auf Berührungsschutz achten.  
 Protect against contact.  
 Veiller à la protection contre les contacts directs.  
 Prestare attenzione alla protezione.  
 Tener en cuenta la protección ante contacto.

D	L1	L2
∅ 20h7	41	43.5
∅ 25h7	41	43.5
∅ 30h7	41	43.5
∅ 38h7	56	58.5
∅ 40h7	56	58.5
∅ 48h7	56	58.5
∅ 50h7	56	58.5

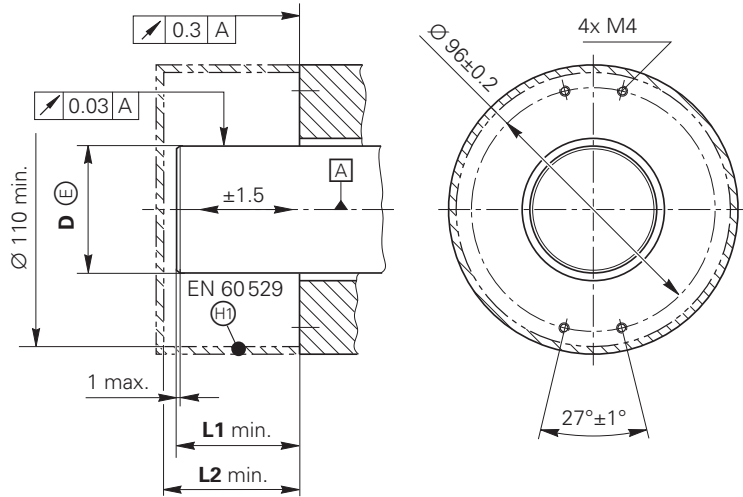

Ⓜ = Lagerung  
 Bearing  
 Roulement  
 Cuscinetto  
 Rodamiento

## Anschlussbelegung

**Pin Layout**  
**Raccordements**  
**Piedinatura**  
**Distribución del conector**

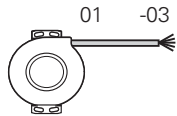

Außenschirm mit Gehäuse verbunden  
 External shield connected to housing  
 Blindage extérieur connecté au boîtier  
 Schermo del cavo collegato alla carcassa  
 Apantallado exterior unido a la carcasa

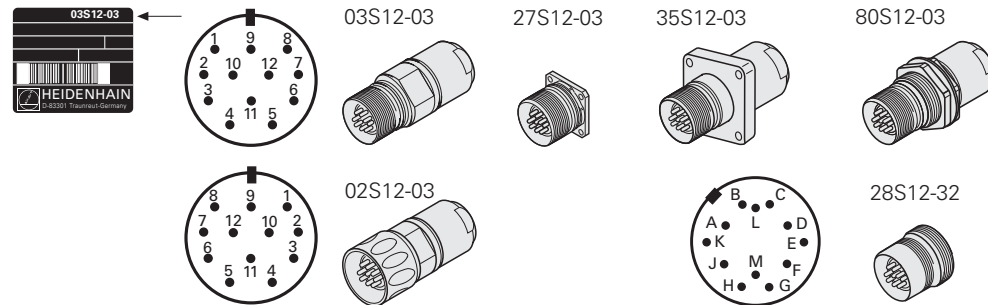

	12	2	10	11	5	6	8	1	3	4	7	/	9
	M	B	K	L	E	F	H	A	C	D	G	/	J
	U <sub>p</sub>	Sensor U <sub>p</sub>	0V	Sensor 0V	U <sub>a1</sub>	U <sub>a1</sub>	U <sub>a2</sub>	U <sub>a2</sub>	U <sub>a0</sub>	U <sub>a0</sub>	U <sub>aS</sub>	/	/
	●	●	●	●									
⚡	BNGN	BU	WHGN	WH	BN	GN	GY	PK	RD	BK	VT	YE	/

## Montage Assembly Montage Montaggio Montaje

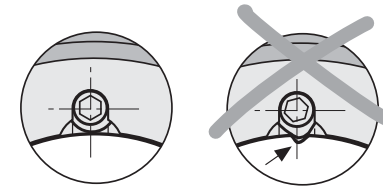

**Achtung:** Exzenter nur bei montierten Messgerät festziehen, Messgerät kann beschädigt werden!

**Caution:** To avoid damage to the encoder, do not tighten the eccentric screw until the encoder is mounted!

**Attention:** Ne serrer l'excentrique qu'une fois le système de mesure monté. Celui-ci ne doit pas être endommagé!

**Attenzione:** Fissare gli eccentrici solo con il sistema montato, il sistema può venire danneggiato.

**Atención:** Sujetar la excéntrica sólo durante el montaje del sistema de medición. ¡El sistema de medición puede resultar dañado!

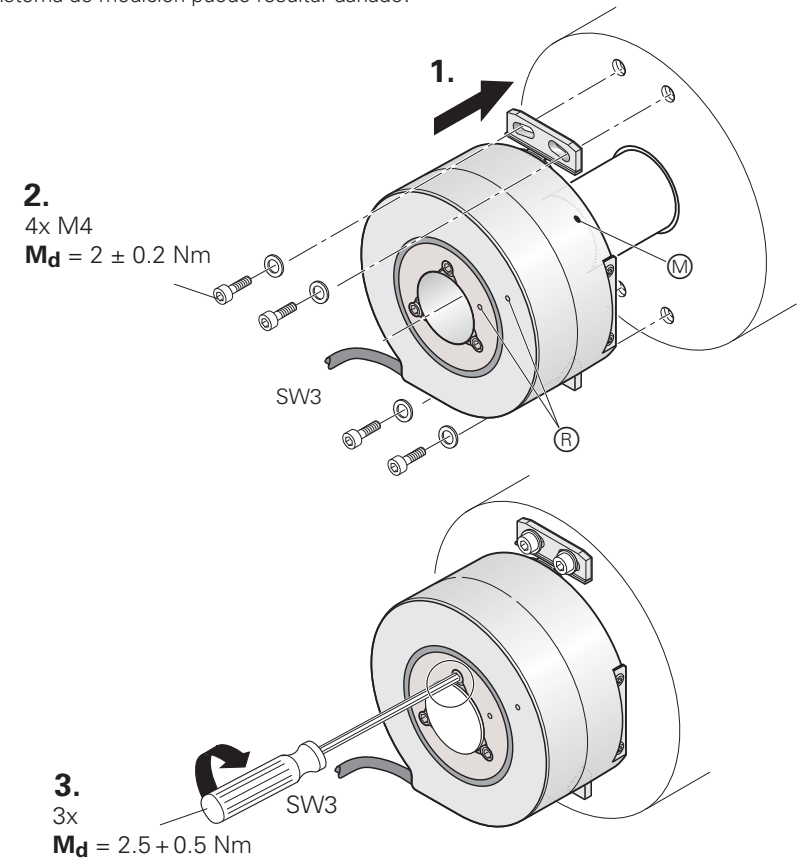

Ⓜ = Referenzmarkenlage ± 15°  
 Reference mark position ± 15°  
 Marque de référence ± 15°  
 Indici di riferimento ± 15°  
 Marca de referencia ± 15°

Ⓜ = Messpunkt Arbeitstemperatur  
 Measuring point for operating temperature  
 Point de mesure température de travail  
 Punto di misura - temperatura di esercizio  
 Punto de medición de la temperatura de trabajo