



HEIDENHAIN



Product Information

LIF 171

LIF 181

Incremental
Linear Encoders

LIF 171

LIF 181

Incremental linear encoders

- For measuring steps down to 100 nm
- Easy mounting with PRECIMET® adhesive film, or fastening with fixing clamps
- Distance-coded reference marks
- For large measuring lengths of up to 3 m
- Measuring lengths of up to 6 m upon request

Scale in clamped condition

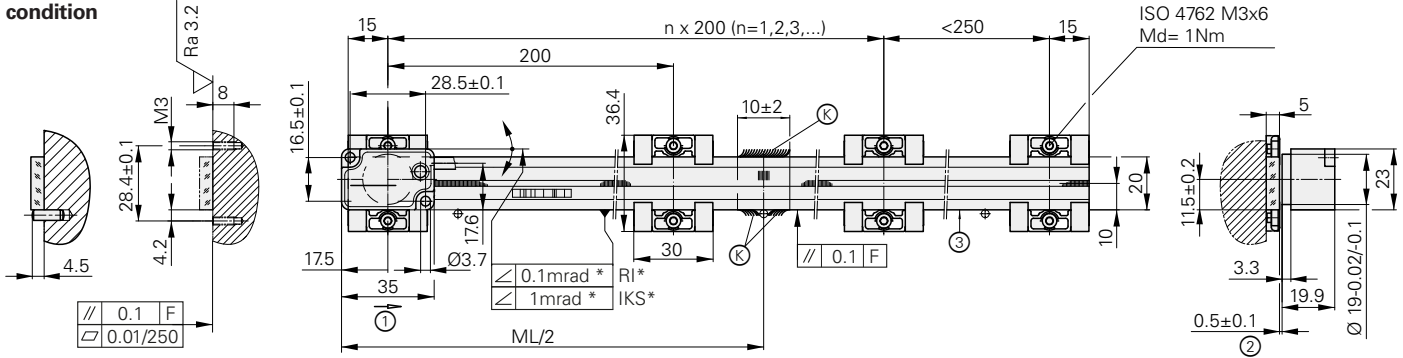

Fixed-point bond for odd number of fixing clamps

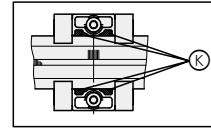

Scale in bonded condition

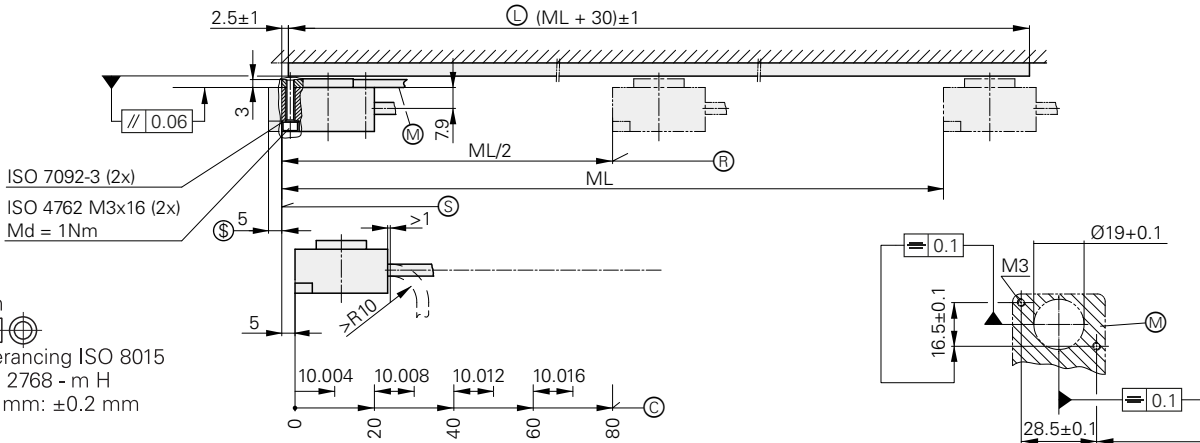
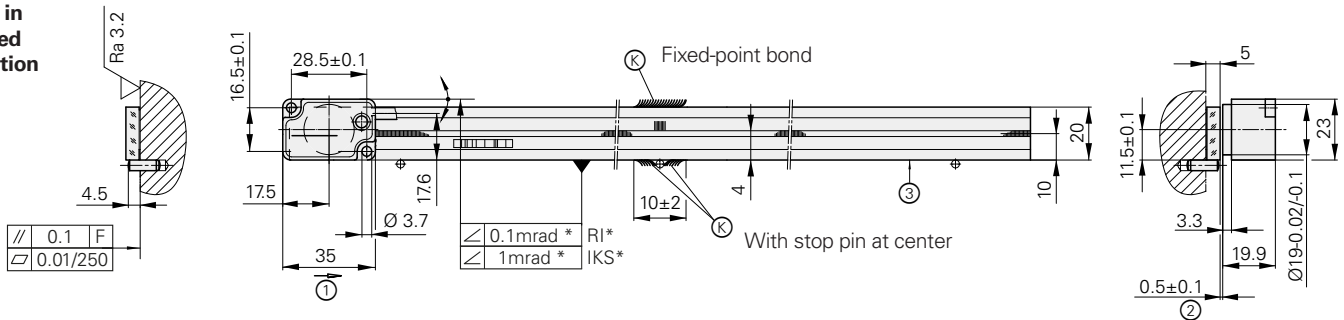

mm
 Tolerancing ISO 8015
 ISO 2768 - m H
 ≤ 6 mm: ±0.2 mm

- ⊗ = Adhesive
- Ⓛ = Scale length
- F = Machine guideway
- * = Max. change during operation
- Ⓡ = Reference mark position LIF 101 R / 171 R / 181 R
- Ⓢ = Reference mark positions LIF 101 C / 171 C / 181 C
- Ⓣ = Beginning of measuring length ML
- Ⓤ = Permissible overtravel
- Ⓜ = Mounting surface for scanning head
- 1 = Positive direction of motion
- 2 = Mounting clearance between scanning head and scale
- 3 = Scale stop surface
- ML = Measuring length

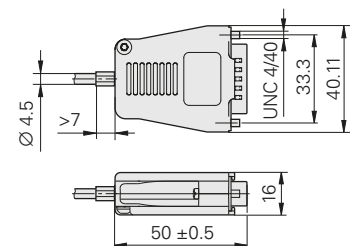

Scale	LIF 101												
Measuring standard Coefficient of linear expansion	SUPRADUR phase grating on Zerodur glass-ceramic or glass; grating period: 8 µm $\alpha_{\text{therm}} \approx (0 \pm 0.1) \times 10^{-6} \text{ K}^{-1}$ (Zerodur glass-ceramic) $\alpha_{\text{therm}} \approx 8 \times 10^{-6} \text{ K}^{-1}$ (glass)												
Accuracy grade	±3 µm; ±1 µm (only in Zerodur and up to a measuring length of 1640 mm)												
Baseline error	≤ ±0.175 µm/5 mm												
Measuring length ML* in mm	70	120	170	220	270	320	370	420	470	520	570	620	670
	720	770	820	870	920	970	1020	1140	1240	1340	1440	1540	1640
	1840	2040	2240	2440	2640	2840	3040 ³⁾						
Reference marks* LIF 101 R LIF 101 C	One reference mark at midpoint of measuring length Distance-coded												
Mass	75 g + 0.25 g/mm of measuring length												
Scanning head	LIF 18	LIF 17											
Interface	~ 1 V _{PP}	TTL											
Integrated interpolation* Signal period	– 4 µm	5-fold 0.8 µm				10-fold 0.4 µm							
Cutoff frequency –3 dB	≥ 1 MHz	–											
Scanning frequency	–	≤ 200 kHz	≤ 100 kHz	≤ 50 kHz	≤ 100 kHz	≤ 50 kHz	≤ 25 kHz						
Edge separation a	–	≥ 0.220 µs	≥ 0.465 µs	≥ 0.950 µs	≥ 0.220 µs	≥ 0.465 µs	≥ 0.950 µs						
Traversing speed ¹⁾	≤ 240 m/min	≤ 48 m/min	≤ 24 m/min	≤ 12 m/min	≤ 24 m/min	≤ 12 m/min	≤ 6 m/min						
Interpolation error Position noise RMS	±12 nm 0.6 nm (1 MHz ²⁾)	–											
Electrical connection*	Cable, 0.5 m/1 m/3 m, with 15-pin D-sub connector (male); interface electronics in connector												
Cable length	With HEIDENHAIN cable: ≤ 30 m												
Supply voltage	DC 5 V ±5 %	DC 5 V ±5 %											
Current consumption	≤ 150 mA	≤ 165 mA (without load)											
Vibration 55 Hz to 2000 Hz Shock 6 ms	≤ 200 m/s ² (IEC 60068-2-6) ≤ 500 m/s ² (IEC 60068-2-27)												
Operating temperature Storage temperature	0 °C to 50 °C –20 °C to 70 °C												
Protection EN 60529	IP00; scanning head: IP50												
Mass	Scanning head	25 g (without cable)											
	Cable	38 g/m											
	Connector	75 g											

* Please select when ordering







¹⁾ Only for TTL: Maximum traversing speed for referencing: 9.6 m/min · (40 kHz)

²⁾ –3 dB cutoff frequency of the subsequent electronics

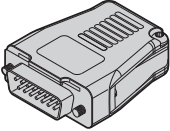
³⁾ Measuring lengths of up to 6 m upon request

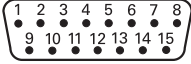
Electrical connection

LIF 171/181 pin layout

15-pin D-sub connector														
  														
	Power supply				Incremental signals						Other signals			
	4	12	2	10	1	9	3	11	14	7	13	8	6	15
 TTL	U _P	Sensor 5 V	0 V	Sensor 0 V	U _{a1}	U _{a1} ⁻	U _{a2}	U _{a2} ⁻	U _{a0}	U _{a0} ⁻	U _{aS} ⁻	Vacant	Vacant	PWT ¹⁾
 1V _{PP}	● — ●		● — ●		A+	A-	B+	B-	R+	R-	Not vacant			Not vacant
 2)	Brown/ Green	Blue	White/ Green	White	Brown	Green	Gray	Pink	Red	Black	Violet	Vacant	Vacant	Yellow



Shield on housing; **U_P** = Power supply

Sensor: The sensor line is connected in the connector with the corresponding power supply
Unused pins or wires must not be assigned!

¹⁾ Conversion of TTL/11 μA_{PP} for PWT

²⁾ Color assignment of the connecting cable

Connecting cables

PUR connecting cable 6 × (2 × 0,19 mm ²); A _V = 0,19 mm ²			
PUR connecting cable 4 × (2 × 0,16 mm ²) + (4 × 0,5 mm ²); A _V = 0,5 mm ²		∅ 8 mm	∅ 6 mm ¹⁾
15-pin D-sub (female) to free cable end		332433-xx	355209-xx
15-pin D-sub connector (female) and 15-pin D-sub connector (male)		335074-xx	355186-xx

¹⁾ Max. total cable length: 9 m

A_P: Cross section of power supply lines

HEIDENHAIN

DR. JOHANNES HEIDENHAIN GmbH

Dr.-Johannes-Heidenhain-Straße 5

83301 Traunreut, Germany

☎ +49 8669 31-0

FAX +49 8669 32-5061

E-mail: info@heidenhain.de

www.heidenhain.de

This Product Information supersedes all previous editions, which thereby become invalid. The basis for ordering from HEIDENHAIN is always the Product Information document edition valid when the order is made.



Further information:

Comply with the requirements described in the following documents to ensure correct operation:

- Brochure: *Interfaces of HEIDENHAIN Encoders*
- Brochure: *Exposed Linear Encoders*

1078628-xx

208960-xx