

SENC 150

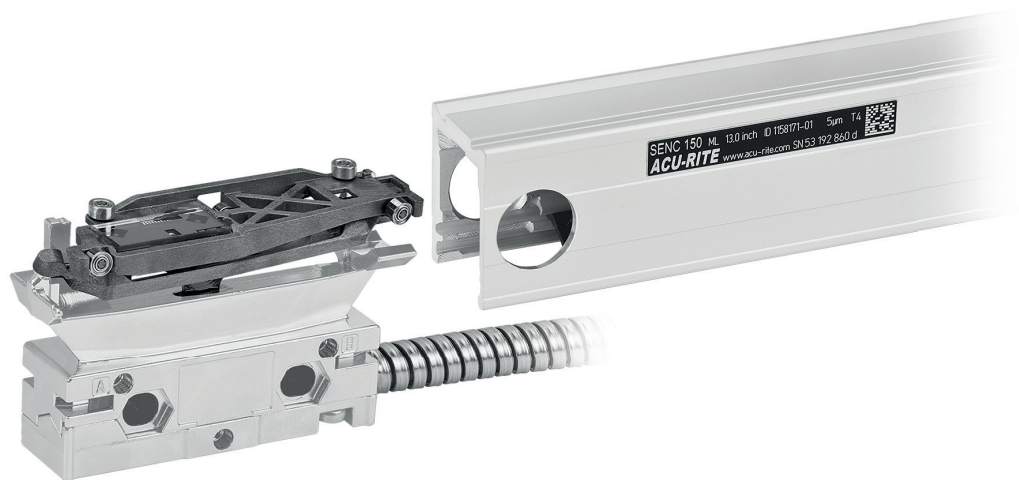

READING HEAD REPLACEMENT INSTRUCTIONS

ACU-RITE®

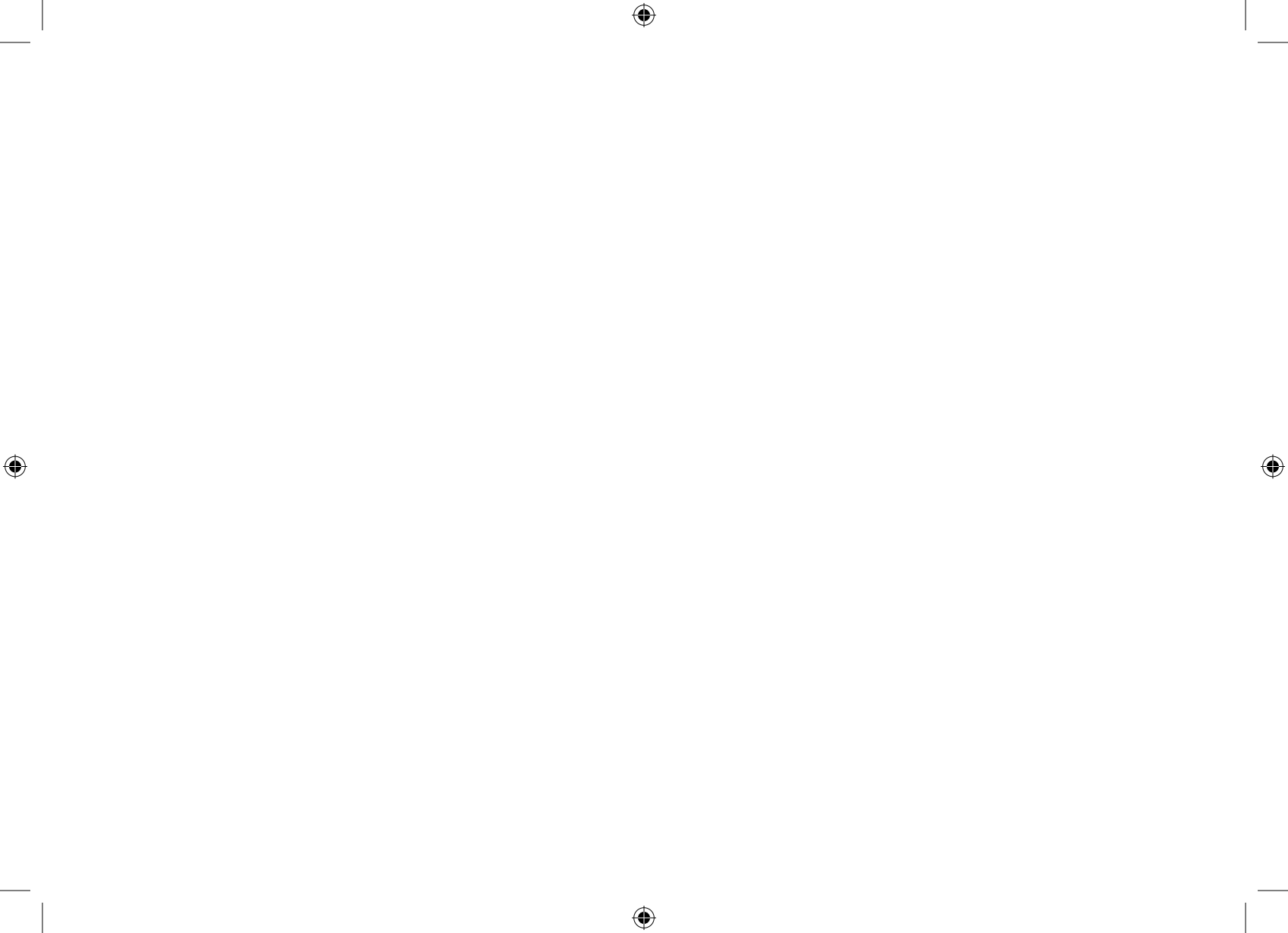

| | Page |
|---|------|
| 1 Introduction / Supplied items | 4 |
| 2 Preparing the removal | 5 |
| 3 Removing the encoder | 6 |
| 4 Removing the reading head | 7 |
| 5 Cleaning the scale | 7 |
| 6 Inserting the reading head | 8 |
| 7 Preparing the remounting | 9 |
| 8 Remounting the encoder assembly | 10 |
| 9 Checking the mounting | 11 |

 **DIN EN 100 015 – 1**
CECC 00015 – 1

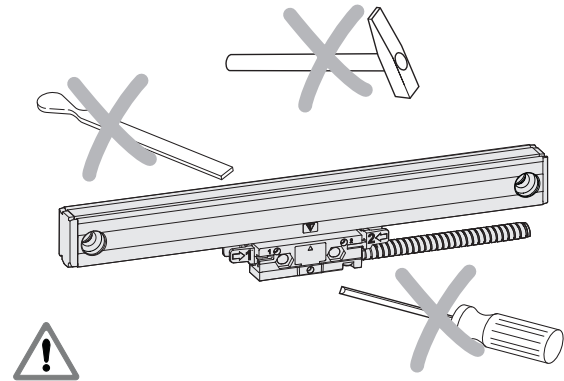
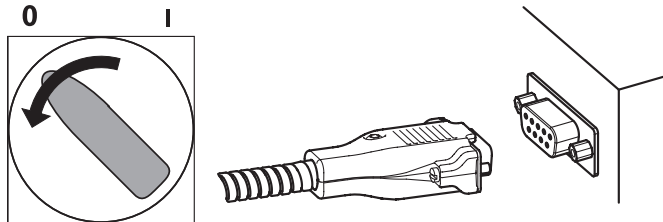
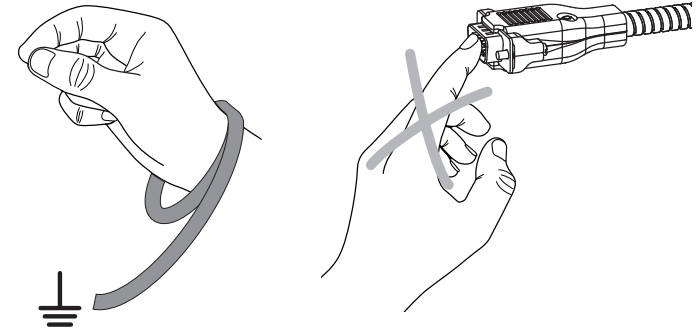

Before you begin:

- Read the instructions completely before replacing the reading head.
- Please ensure that no further damage occurs while removing the reading head.

⚠ Note: Mounting and commissioning is to be conducted by a qualified specialist under compliance with local safety regulations. Do not engage or disengage any connections while under power. The system must be disconnected from power.

Contents

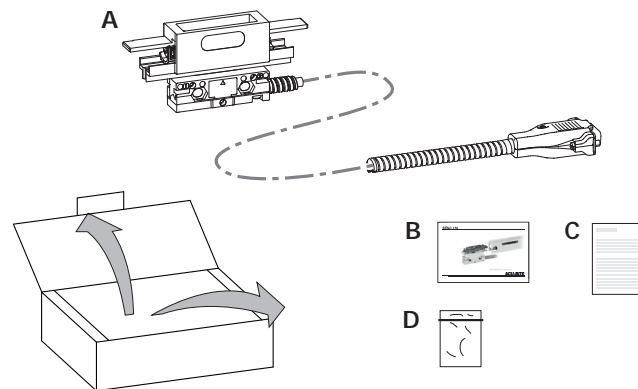

Contents key

- A ▪ SENC 150 reading head
- B ▪ Reference manual
- C ▪ Disposal notice
- D ▪ Head replacement hardware kit

Preparing the removal

- Remove all cable ties or retaining clips.
- Disconnect the reading head cable from the readout.

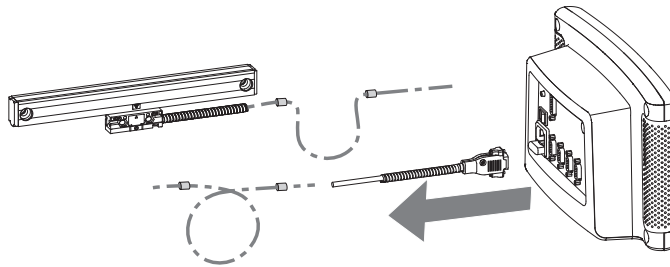

Installing alignment brackets

- Attach the alignment brackets (included in head replacement hardware kit) by inserting the top ears into the bottom grooves in the scale case.
- Numbers and letters on reading head casting and alignment brackets correspond when assembled.

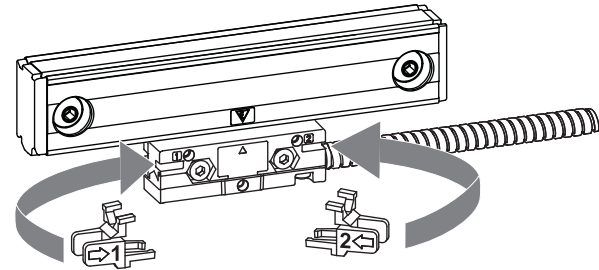

Slide brackets against reading head snap into place.

Insert brackets at 45° and twist to lock in scale groove.

3 Removing the encoder

Removing the reading head screws

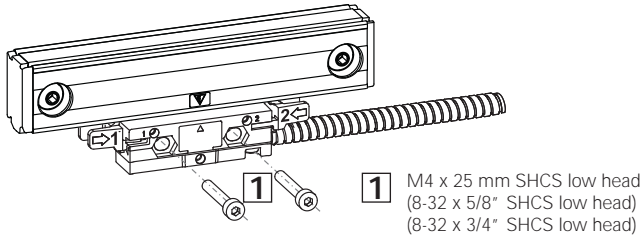

- Do not remove any mounting brackets unless it is completely unavoidable.
- Remove the two reading head mounting fasteners.

Removing the center support

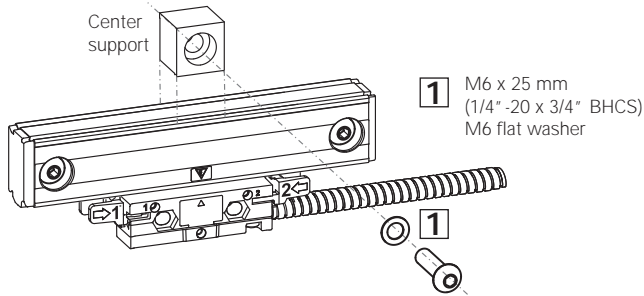

- Remove the fastener from the center support if one is present.

Removing the end hole or set screws

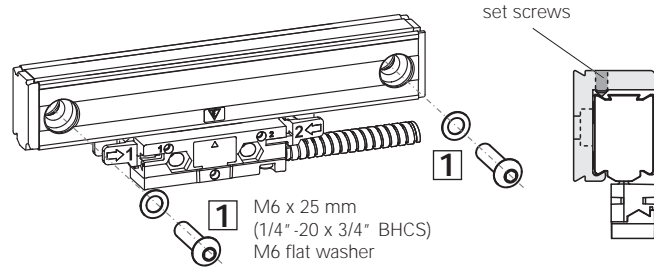

- Remove the end hole mounting fasteners unless encoder is spar mounted, then loosen the set screws and remove the scale case from the spar.

Removing the end cap(s)

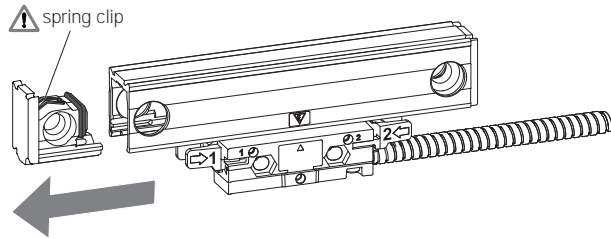

- The reading head can be removed from either end. The view shown is for illustration only. Use caution not to lose the spring clip during the end cap removal.

Removing the reading head

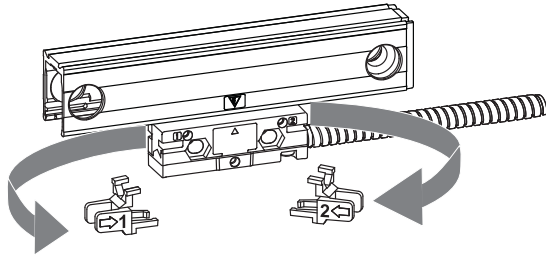

Twist brackets 45° to remove.
Slide brackets away from
reading head and cable.

- Remove the alignment brackets.

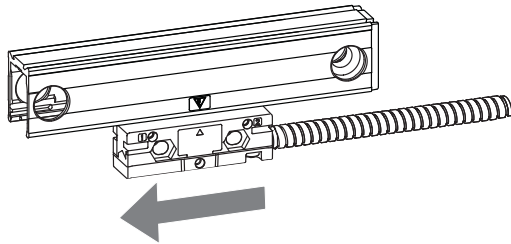

- Gently slide the reading head out of the end of the scale case.
- Place the defective reading head in a safe location.

Cleaning the glass scale

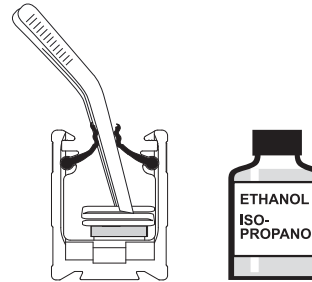

- Saturate a clean cotton swab or lint-free cloth with alcohol.
- Clean the glass scale by wiping the surface and edge. Wipe until no residue is found on the swab or cloth.
- ⚠ Do not scratch the inside of the scale.
 - ⇒ Lip seals may be removed for glass cleaning if desired. Gently pull seals out through the end of the scale case.
 - ⇒ Reinsert the lip seals into the end of the scale case, and gently pull them through the extrusion. Center the seals in the case.

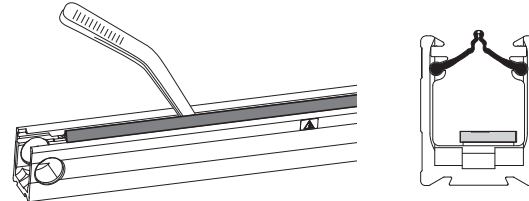

- Run a plastic pin between the lip seals to reset them into position.

6 Inserting the reading head

SENC 150 Reading Head Replacement Instructions

Insertion tool

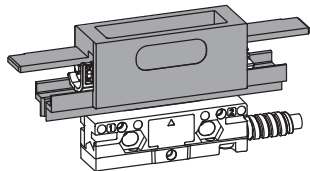

- Remove tape keeping the reading head contained within the insertion tool.

Aligning of insertion tool and scale

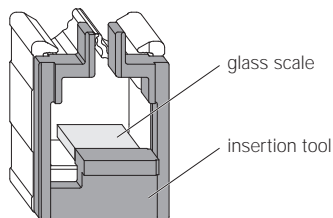

- Note the orientation of the reading head to the insertion tool. The insertion tool and the reading head have to be in alignment.

Inserting the tool

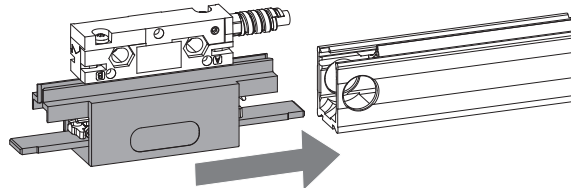

- Push the tool into the end of the scale case until it is stopped by the blade touching the glass.
- Gently slide the reading head assembly onto the scale glass from the tool. Do not force the reading head; it will glide smoothly.
- If resistance is felt, ensure that the tool is inserted correctly into the end of the encoder case.

Inserting the reading head

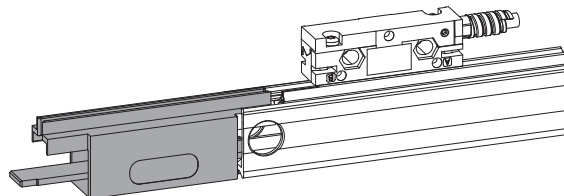

- Slide the reading head gently to the center of the scale case and remove the insertion tool.

Installing alignment brackets

- Attach the alignment brackets provided by inserting the top ears into the bottom grooves in the scale case.
- Numbers and letters on reading head casting and alignment brackets correspond when assembled.

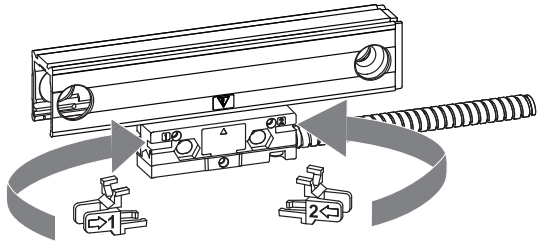

Slide brackets against reading head snap into place.

Insert brackets at 45° and twist to lock in scale groove.

Installing end cap(s)

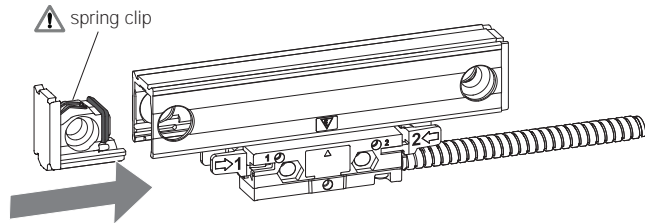

⚠ spring clip

Determining cable direction

- Determine cable exit direction before mounting the encoder.
- To change the cable exit direction, remove the cover plate and rotate it 180°.

K1 - cable exit right side

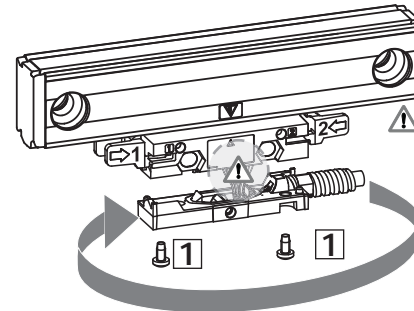

⚠ Do not pull out the PCB!

1 T-10 torx screw

K2 - cable exit left side

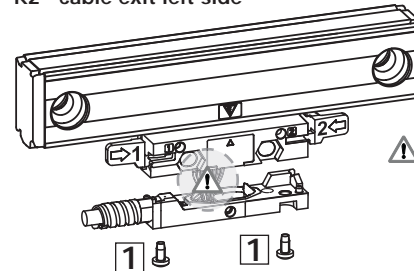

⚠ Do not clamp the wires!

1 T-10 torx screw

max. 70 Ncm!

Remounting the encoder assembly

- Remount the encoder as it was originally installed, using the same brackets, fasteners and spar or support.
- Refer to the encoder manual (ID: 516291-22) as from section 5.

Removing the alignment brackets

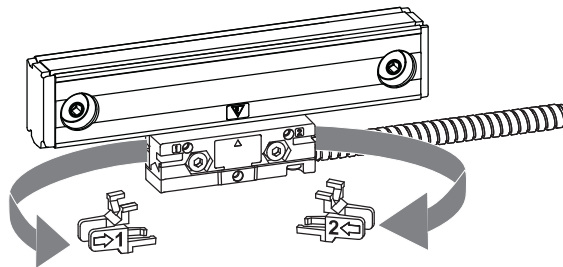

- Slide the brackets away from the reading head.
- Remove the alignment brackets and save for future use.

Connecting the encoder

- Route the cables with slack loops to allow for axis motion.
- Secure excess cable by fastening with clips or ties.
- Attach the linear encoder connectors to the readout.

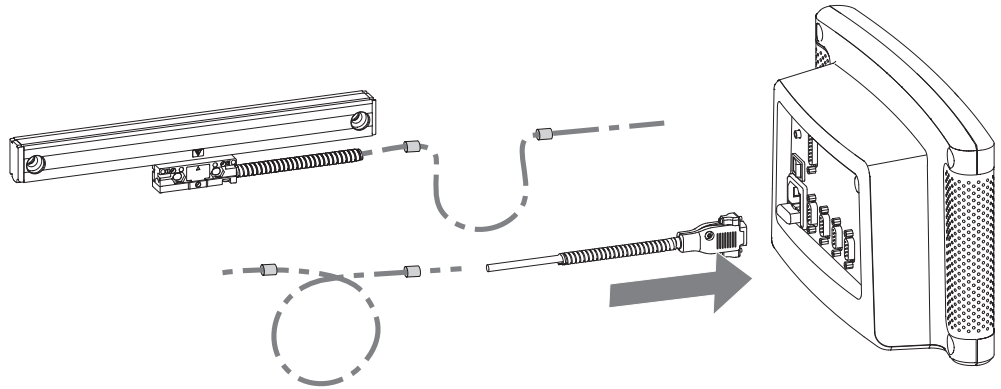

Checking the electrical shielding

- Connect a ground wire from the terminal on the back of the readout to the machine or earth ground.
- Attach a ground wire from the machine to a solid earth ground.
- Check shielding by measuring the resistance between connector housing and scale unit.

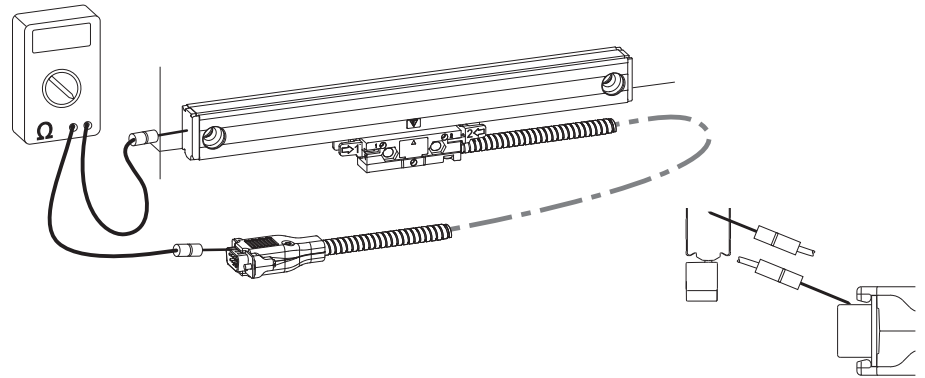

Desired value: 1 Ω max.

HEIDENHAIN

DR. JOHANNES HEIDENHAIN GmbH

Dr.-Johannes-Heidenhain-Straße 5

83301 Traunreut, Deutschland

☎ 08669 31-3121

FAX 08669 32-5061

E-Mail: service.order@heidenhain.de

service.heidenhain.de

HEIDENHAIN CORPORATION

333 East State Parkway

Schaumburg, IL 60173-5337, USA

☎ +1 847 490-1191

FAX +1 847 490-3931

E-mail: info@heidenhain.com

www.heidenhain.com

ACU-RITE®

**ISO 9001
CERTIFIED**

