

RCML15 Mounting Instructions - Data Only

Verify that you received the following items:

- Encoder
- .048" Four Flute Spline Wrench
- (2) 2-56 X 3/8 T8 TORX Screws with integral flat washers

RCML15 Preparation

CAUTION ---- ESD Precautions Apply ---- CAUTION

Rotate hub until setscrew aligns with midpoint mark. ([Figure 1](#))

Ensure that the slide lock mechanism is pulled out completely (installation position). You may hear a click when hub engages with centering mechanism as slide lock is pulled out. ([Figure 2](#))

Note: When setscrew is aligned with midpoint mark, the index output will be within 10 degrees mechanical of the index sensors on the encoder.

Step 1

With the slide lock mechanism pulled out completely, align hub with motor shaft and gently press down on hub to insure the encoder is resting on mounting surface. ([Figure 3](#))

Do not push down on encoder, push on hub only!

Step 2

Press down on top of hub with 2 pounds of pressure. Release pressure and reapply 1/2 pound of pressure on hub. Using supplied wrench, secure the hub setscrew with 20 oz-in torque (60 degrees rotation on the end of the wrench.)

CAUTION: Over tightening the setscrew will Brinell the shaft making it difficult to remove encoder.

Step 3

Install supplied mounting screws finger tight in center of each slot, rotating the body of the encoder if necessary. ([Figure 4](#)) Threadlocker may be applied to the mounting screws prior to mounting the encoder to prevent loosening during operation. Install cable assembly. ([Figure 5](#)) If index alignment is not required, go to step 5.

Step 4

Reference system so motor can find the index. While the index is present and the shaft is being held in position by the drive, the encoder can be turned to align the shaft with respect to the motor. ([Figure 5](#))

Step 5

Secure mounting screws to 40 oz-in torque. Slight compression of encoder cover is normal. Push in slide lock mechanism to operating position. ([Figure 2](#)) High speed or high accel/decel applications require hub to be bonded to shaft. ([Bonding and Debonding Methods](#))

Encoder is now ready for operation. ([Figure 6](#))

Encoder Removal

Lift end of connector locking tab ([Figure 6](#)) and gently remove cable assembly.

Loosen setscrew in hub.

Change: General Update

	Release-no.		Created	Responsible	Released	Version	Rev.	Sheet	Page
	13676	Name	Dupuis	Dupuis	Setbacken	D548182 - 00 - A - 01			1/
		Date	11.05.2005	20.06.2006	20.06.2006	Document no.			4

If hub was bonded to shaft, debond using recommended method. ([Bonding and Debonding Methods](#))

Remove mounting screws.

Pull slide-lock mechanism to full extended position (installation position). ([Figure 2](#))

Remove encoder.

FIGURE 1

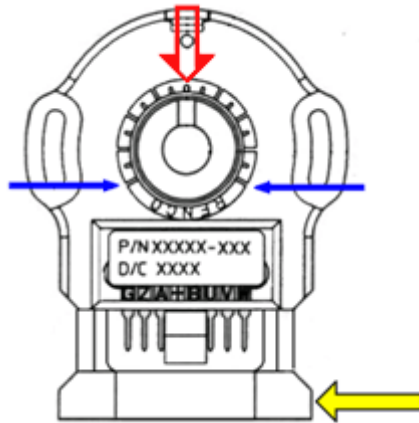

- Red arrow = Midpoint mark (9 marks from end marks)
- Blue arrows = End marks
- Yellow arrow = Slide lock mechanism

FIGURE 2

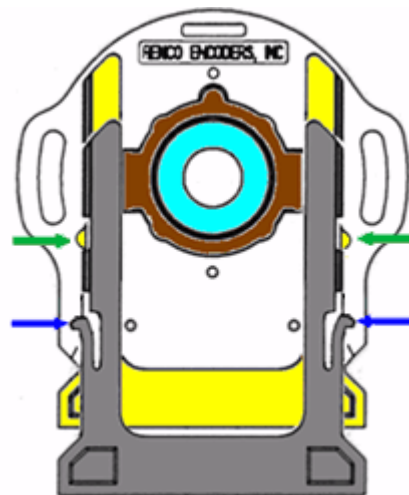

- Blue arrow = Installation position
- Green arrow = Operating position
- Blue area = Hub
- Brown area = Centering Ring
- Grey area = Extended slide-lock mechanism
- Yellow area = Slide-lock in operating position

FIGURE 3

This document is the property of RENCO Encoders and is submitted in confidence. Disclosure, reproduction or publication without written authorization is prohibited.

	Release-no.		Created	Responsible	Released		Version	Rev.	Sheet	Page
	13676	Name	Dupuis	Dupuis	Setbacken	D548182 - 00 - A - 01			2/	4
		Date	11.05.2005	20.06.2006	20.06.2006	Document no.				

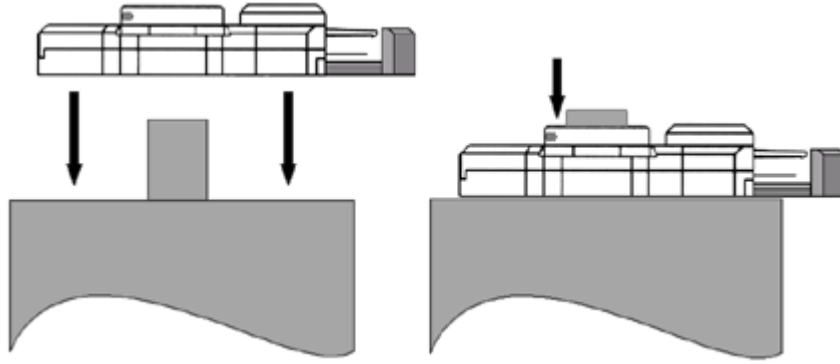

FIGURE 4

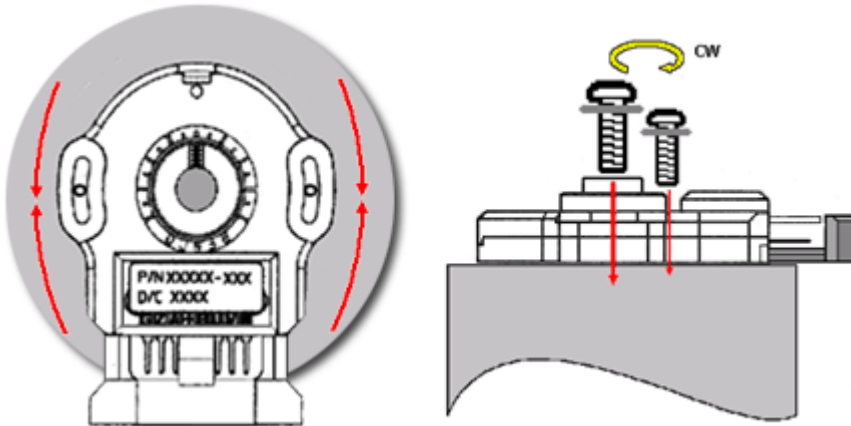

FIGURE 5

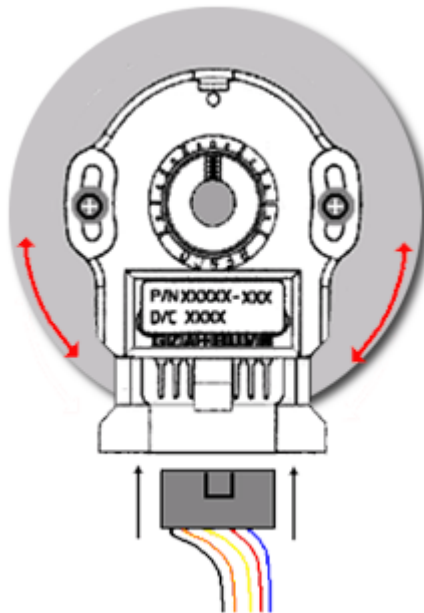

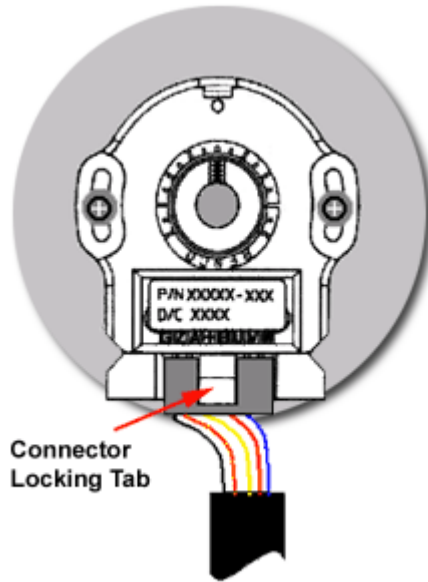



FIGURE 6

	Release-no.		Created	Responsible	Released	Version	Rev.	Sheet	Page
	13676	Name	Dupuis	Dupuis	Setbacken	D548182 - 00 - A - 01			3/
		Date	11.05.2005	20.06.2006	20.06.2006	Document no.			4



[RETURN TO TOP](#)

	Release-no.		Created	Responsible	Released		Version	Rev.	Sheet	Page
	13676	Name	Dupuis	Dupuis	Setbacken	D548182	- 00 - A - 01			4/
		Date	11.05.2005	20.06.2006	20.06.2006	Document no.				4