

**R35i Mounting Instructions, Data Only**  
**Montageanleitung**

**Verify that you received the following items:**

- Encoder
- Cover
- Setscrew wrench
- M2.5 or #2-56 UNC Torx Head Mounting Screws with Captive Washer for C or H option
- M2.5 or #4-40 UNC Socket Head Cap Screws for C4 or H4 option

**Before you begin:**

The following instructions are for random index location with respect to the shaft. If the index output needs to be aligned to the shaft, please contact factory for appropriate method for your motor type.

**CAUTION ---- ESD Precautions Apply ---- CAUTION**

**Encoder Preparation**

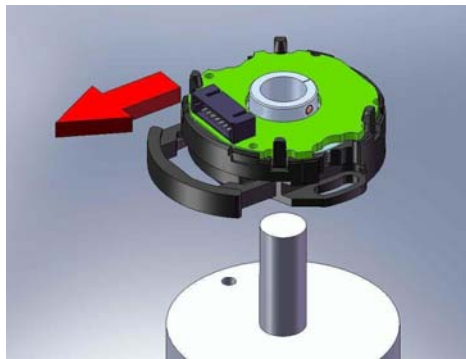

**Verify that the slide lock mechanism is fully extended. If needed, apply thread locker to the mounting holes.**

**Step1**

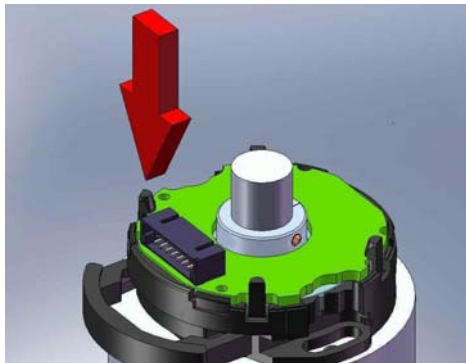

**Slide encoder onto the motor shaft.**

**Step 2**

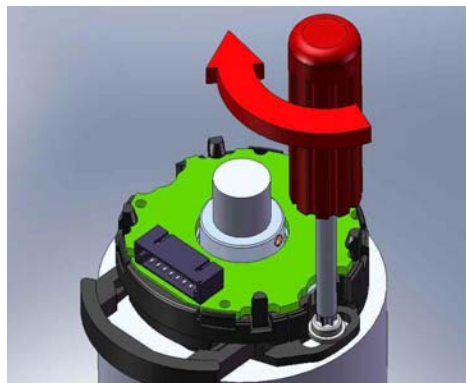

**Install mounting screws finger tight, then torque to 0,21 ± 0,03 Nm (35-40 oz-in).**

This document is the property of RENCO Encoders and is submitted in confidence. Disclosure, reproduction or publication without written authorization is prohibited.

542543

Change: Metrical torque values are added.

	Release-no.		Created	Responsible	Released	Version	Rev.	Sheet	Page
	<b>C001256-</b>	Name	Obermayer	Obermayer	Tresenreiter	<b>D548176 - 02 - A - 01</b>			1/
		Date	03.04.2014	01.12.2010	15.04.2014	Document no.			3

**Step 3**

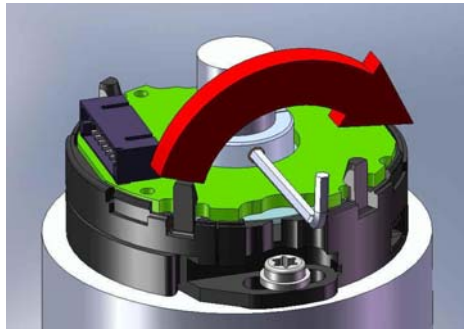

**Torque set screw to  $0,16 \pm 0,03$  Nm (20 oz-in). Bond hub to shaft for high acceleration or deceleration applications.**

**Step 4**

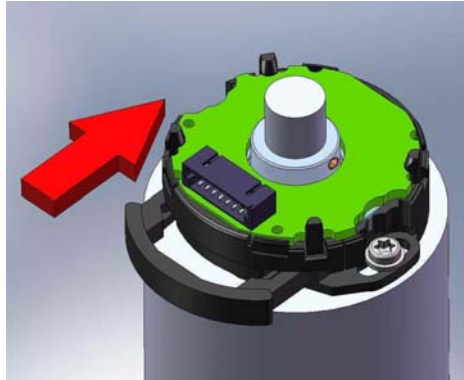

**Push in slide lock mechanism.**

**Step 5**

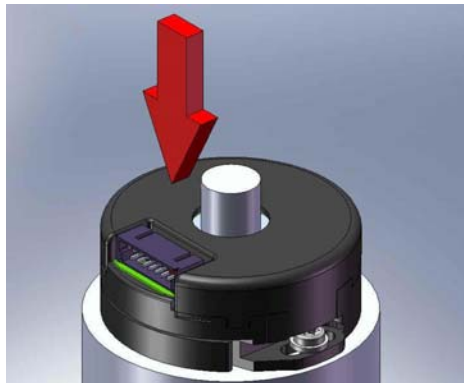

**Install cover.**

**Step 6**



**Install cable.**

	Release-no.		Created	Responsible	Released		Version	Rev.	Sheet	Page
	<b>C001256-</b>	Name	Obermayer	Obermayer	Tresenreiter	<b>D548176</b>	<b>- 02 - A - 01</b>		2/	3
		Date	03.04.2014	01.12.2010	15.04.2014	Document no.				

This document is the property of RENCO Encoders and is submitted in confidence. Disclosure, reproduction or publication without written authorization is prohibited.

**Mounting accessories for Renco R35i:**

**350379-10 Torque driver with 1/4" bit holder**  
with adjustable torque range 0,02 Nm to 0,3 Nm

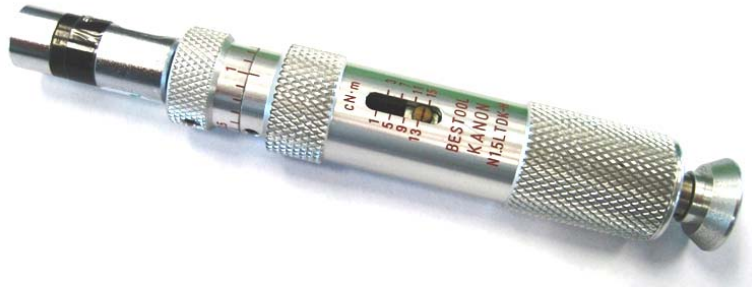

**825869-01 Special screwdriver bit set Bristol 4-Spline**  
for hub setscrew for following shaft diameters: 3/8 inch or 3/8+ inch

The screwdriver bit set includes following parts:

- 1/4" adapter with 0.048-4-Spline Bristol bit
- wrench for replacing the bit
- 10 units 0.048-4-Spline Bristol bits as spare parts



**756768-43 Special screwdriver bit 0.89 mm Hexagon**  
to tighten the hub setscrew for following shaft diameters:  
1/8, 1/8+, 3/16, 3/16+, 1/4, 1/4+, 5/16, 5/16+ inch,  
4mm, 5mm, 6mm, 8mm

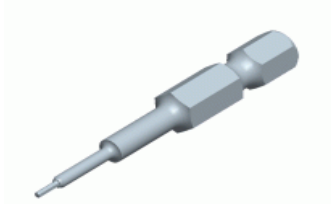

**Support**

For Support in the U.S., Canada and Mexico, Please Contact

HEIDENHAIN Corporation  
Phone: 847-490-1191  
Fax: 847-490-3931  
Mail:renco@heidenhain.com  
333 State Parkway  
Schaumburg, IL 60173-5337

	Release-no.		Created	Responsible	Released	Version	Rev.	Sheet	Page
	<b>C001256-</b>	Name	Obermayer	Obermayer	Tresenreiter	<b>D548176 - 02 - A - 01</b>			3/
		Date	03.04.2014	01.12.2010	15.04.2014	Document no.			3