

# SENC 150

---



REFERENCE MANUAL

**ACU-RITE®**

---

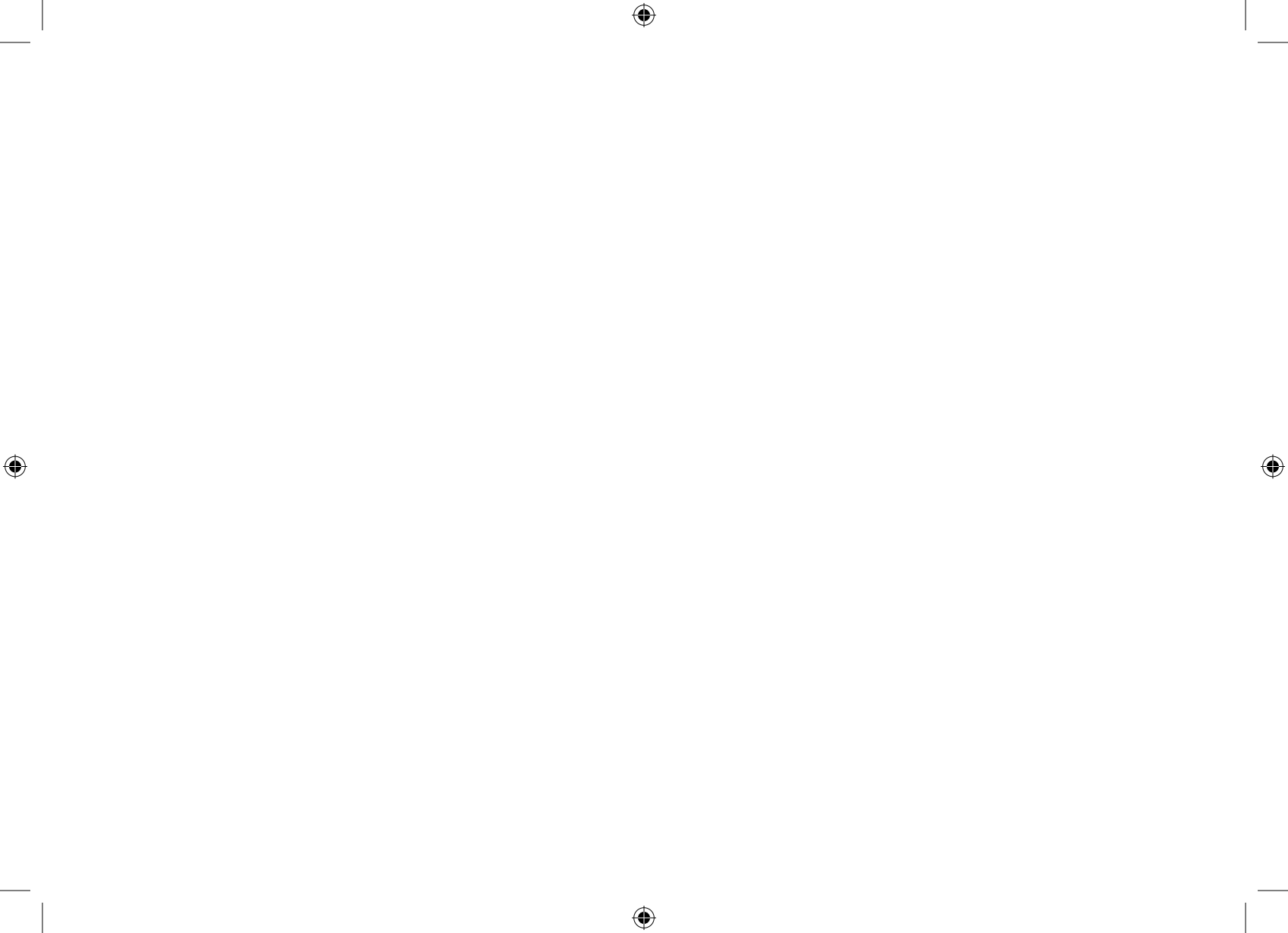

	Page
1 Introduction / Supplied items .....	4
2 Preparing the mounting / Mounting information .....	5
3 Encoder dimensions .....	8
4 Backup spar dimensions .....	10
5 Mounting the encoder without backup spar .....	11
5.1 Mounting the encoder via end holes .....	12
5.2 Mounting the encoder via center support .....	13
6 Mounting the encoder with backup spar .....	14
7 Mounting the reading head .....	15
8 Checking the mounting .....	16
9 Specifications .....	17
10 Pin-outs .....	18
11 Output signals .....	18

 **DIN EN 100 015 – 1**  
**CECC 00015 – 1**

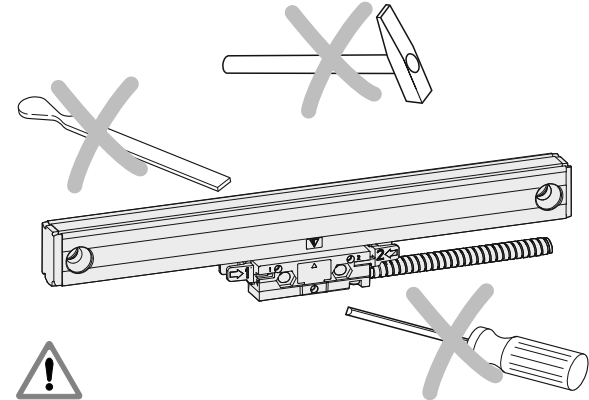
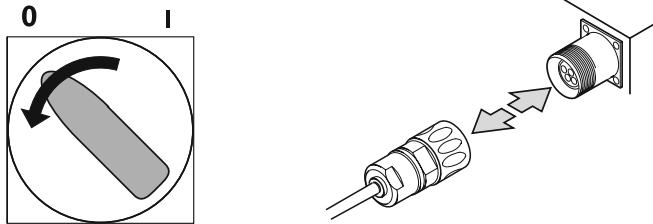
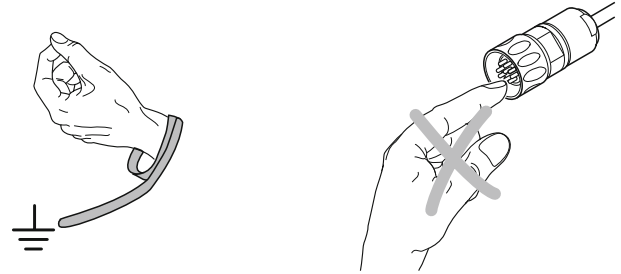

The SENC 150 precision glass scale linear encoder provides the accuracy and reliability of an **ACU-RITE®** measuring system with digital output. Features and options include:

- Resolutions of 0.5, 1, or 5  $\mu\text{m}$ .
- Accuracy grades of  $\pm 3$ , and  $\pm 5 \mu\text{m}/1000 \text{ mm}$ .
- Vinyl or armor cables of 5, 13, and 19 ft. length.
- Distance-coded reference marks.

**⚠ Note:** Mounting and commissioning is to be conducted by a qualified specialist under compliance with local safety regulations. Do not engage or disengage any connections while under power. The system must be disconnected from power.

### Contents key

- A** ▪ SENC 150 linear encoder
- B** ▪ Backup spar
- C** ▪ Reference manual
- D** ▪ Cable mounting hardware
- E** ▪ Linear encoder mounting hardware
- F** ▪ Backup spar mounting hardware
- G** ▪ Quality test certificate

### Contents ML $\leq 1550 \text{ mm}$ (60")

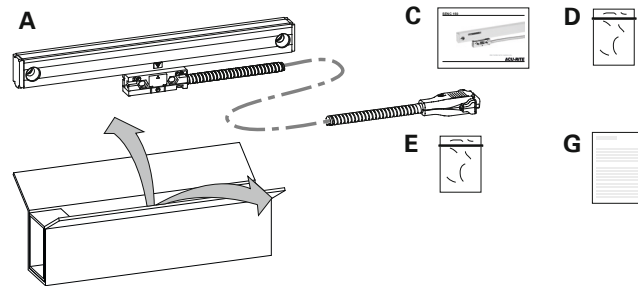

### Contents ML $\geq 1675 \text{ mm}$ (65")

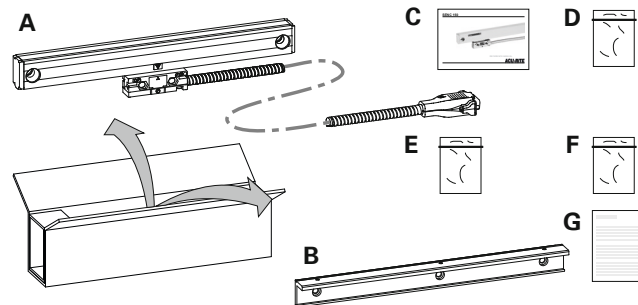

- Mounting surface clean and free of paint.

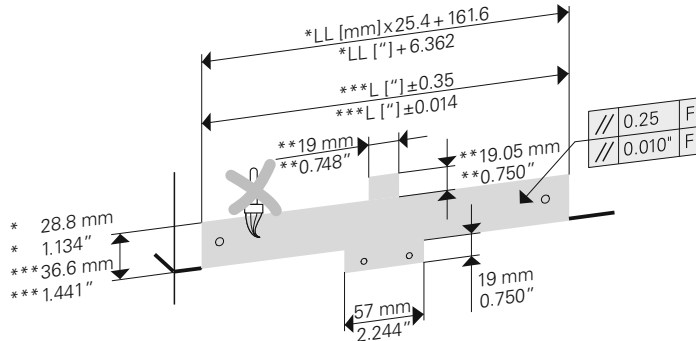

\* Linear encoder  
 \*\* Linear encoder with center support  
 \*\*\* Linear encoder with backup spar  
 F = Machine guideway  
 L = Length of backup spar (page 10)

LL [mm]	LL ["]
50	1
75	2
100	3
125	4
150	5
175	6
200	7
225	8
275	10
300	11
125	12
350	13
375	14

LL [mm]	LL ["]
400	400
425	16
475	18
525	20
575	22
600	23
625	24
675	26
725	28
775	30
875	33
925	35
950	36

LL ["]	LL ["]
1000	38
1050	40
1100	42
1250	48
1350	52
1400	54
1550	60
1675	65
1850	72
2000	78
2150	84
2300	90
2575	100
2825	110
3075	120

- Protect sealing lips from splash water.

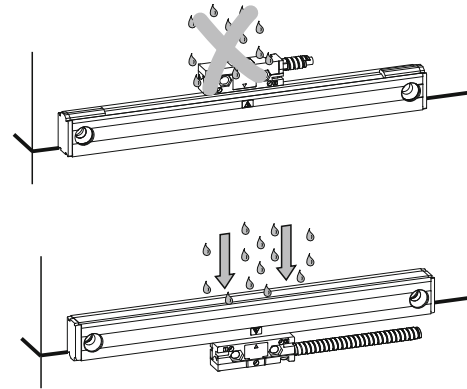

- If there is a risk of severe contamination, attach a protective cover.

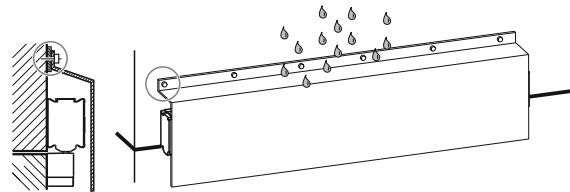

Traverse path

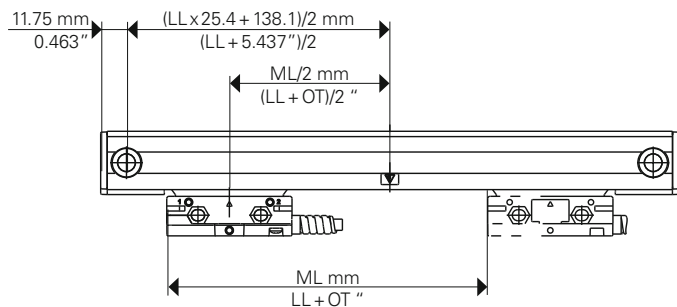

ML = Measuring length  
OT = Overtravel 1.75"

Center mounting axis

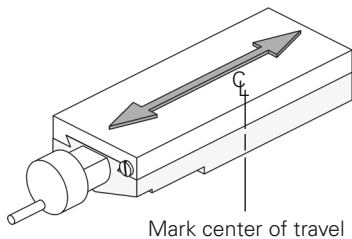

- Move the axis to its center of travel.
- Mark the axis for quick return to center.
- Determine encoder cable exit direction (page 7) and adjust.

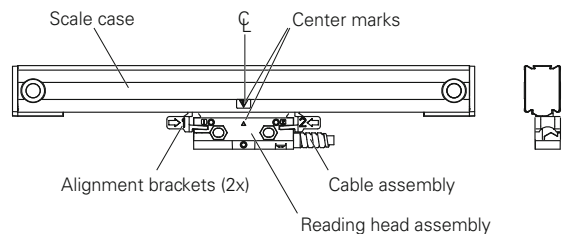

- Align the center marks on the reading head and scale assembly by sliding the reading head and brackets along the scale.

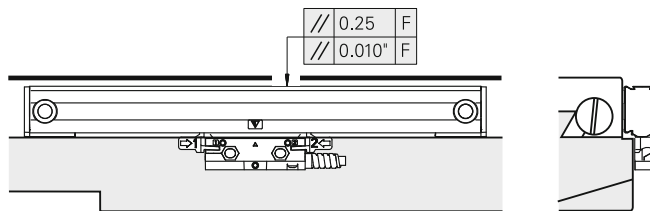

F = Machine guideway

- Locate the scale case so underside of end caps are flush with the axis parting line.
- Mark one end mounting hole location.
- ⚠ Alignment brackets must not be removed until instructed.

**Mounting possibilities**

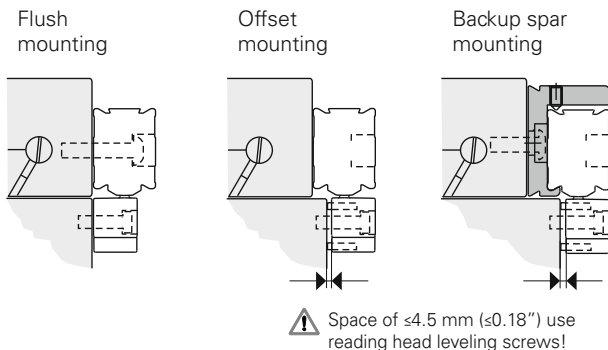

- Use reading head leveling set screws when surfaces are not flush.
- Detailed information about mounting possibilities on page 11 (Mounting the encoder without backup spar) and on page 14 (Mounting the encoder with backup spar).

**Determining cable direction**

- Determine cable exit direction before mounting the encoder.
- To change the cable exit direction, remove the cover plate and rotate it by 180°.

**K1 - cable exit right side**

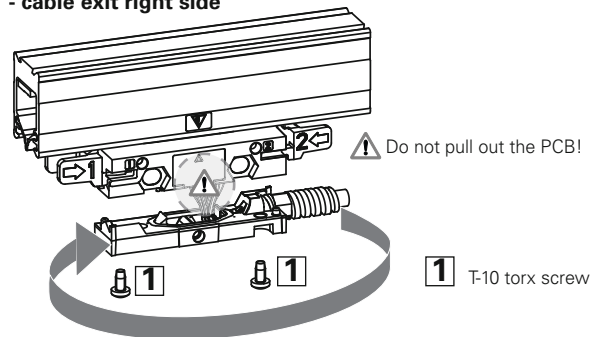

**K2 - cable exit left side**

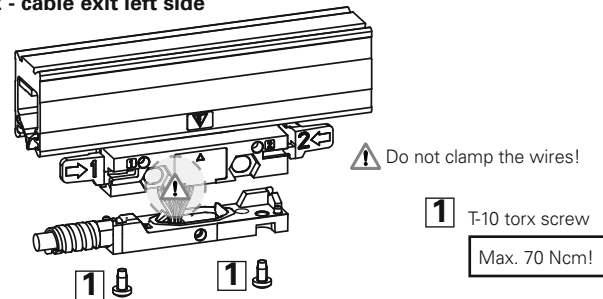

### 3 Encoder dimensions

SENC 150

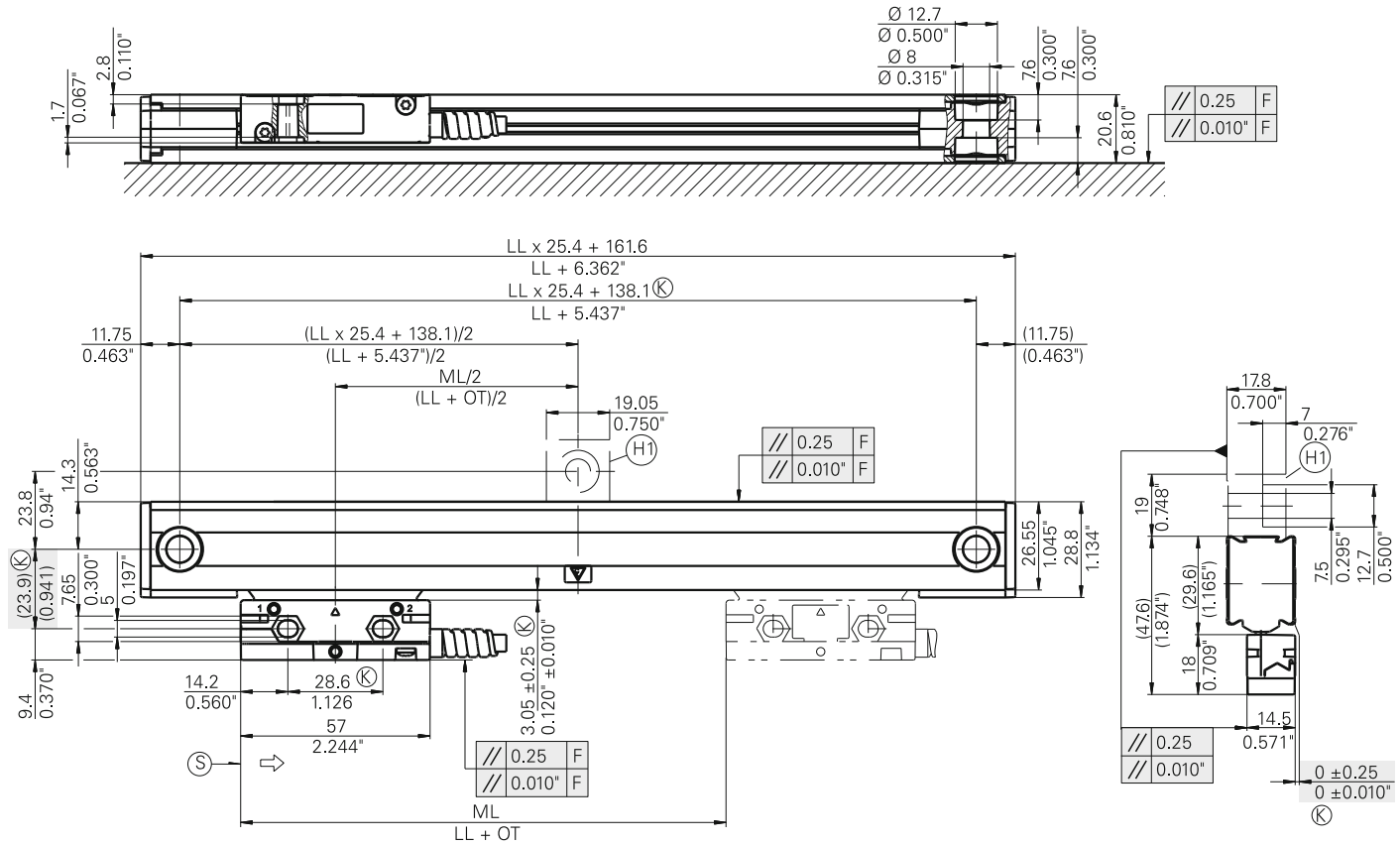



mm  
(Inch)



Tolerancing ISO 8015  
ISO 2768 - m H  
< 6 mm: ±0.2 mm

ML = Measuring length [mm]

LL = Measuring length [inch]

OT = Overtravel 1.75"

(S) = Beginning of measuring length

(K) = Required mating dimensions

(H1) = For ML ≥ 625 mm to ≤ 1550 mm use mid-point fastening  
For ML ≥ 24" to ≤ 60" use mid-point fastening

⇒ = Direction of scanning head motion for output signals  
in accordance with interface description

F = Machine guideway

## 4 Backup spar dimensions

SENC 150

Encoder ML (mm)	Encoder LL (inch)	L (mm)	L (inch)	L1 (mm)	L1 (inch)	L2 (mm)	L2 (inch)	No. holes B
50	1	185.50	7.303	29.25	1.152	127	5	2
75	2	211.50	8.327	42.25	1.663	127	5	2
100	3	236.50	9.311	54.75	2.156	127	5	2
124	4	261.5	10.295	67.25	2.648	127	5	2
150	5	287.50	11.319	80.25	3.159	127	5	2
175	6	312.50	12.303	29.25	1.152	254	10	2
200	7	388.50	13.327	42.25	1.663	254	10	2
225	8	363.5	14.311	54.75	2.156	254	10	2
275	10	414.50	16.319	80.25	3.159	254	10	2
300	11	439.50	17.303	92.75	3.652	254	10	2
325	12	465.50	18.327	105.75	4.163	254	10	2
350	13	490.50	19.311	36.60	1.441	417.3	10	2
375	14	515.50	20.295	130.75	5.148	254	10	2
400	15	541.50	21.319	16.75	0.659	254	10	3
425	16	566.50	22.303	29.25	1.152	254	10	3
475	18	617.50	24.311	54.75	2.156	254	10	3
525	20	668.50	26.319	80.25	3.159	254	10	3
575	22	719.50	28.327	105.75	4.163	254	10	3
600	23	744.50	29.311	118.25	4.656	254	10	3
625	24	769.50	30.295	130.75	5.148	254	10	4
675	26	820.50	32.303	29.25	1.152	254	10	4

Encoder ML (mm)	Encoder LL (inch)	L (mm)	L (inch)	L1 (mm)	L1 (inch)	L2 (mm)	L2 (inch)	No. holes B
725	28	871.50	34.311	54.75	2.156	254	10	4
775	30	922.50	36.319	80.25	3.159	254	10	4
875	33	998.50	39.311	118.25	4.656	254	10	4
925	35	1049.50	41.319	11.25	0.443	256.75	10.108	5
950	36	1074.50	42.303	29.25	1.152	254	10	5
1000	38	1125.50	44.311	54.75	2.156	254	10	5
1050	40	1176.50	46.319	80.25	3.159	254	10	5
1100	42	1227.50	48.327	105.75	4.163	254	10	5
1250	48	1379.50	54.311	54.75	2.156	254	10	6
1350	52	1481.50	58.327	105.75	4.163	254	10	6
1400	54	1531.50	60.295	130.75	5.148	254	10	6
1550	60	1684.50	66.319	80.25	3.159	254	10	7
1675	65	1811.50	71.319	143.75	5.659	254	10	7
1850	72	1989.50	78.327	105.75	4.163	254	10	8
2000	78	2141.50	84.311	54.75	2.156	254	10	9
2150	84	2293.50	90.295	130.75	5.148	254	10	9
2300	90	2446.5	96.319	80.25	3.159	254	10	10
2575	100	2700.50	106.319	80.25	3.159	254	10	11
2825	110	2954.50	116.319	80.25	3.159	254	10	12
3075	120	3208.50	126.319	80.25	3.159	254	10	13

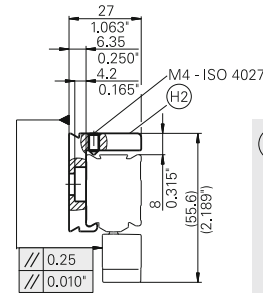
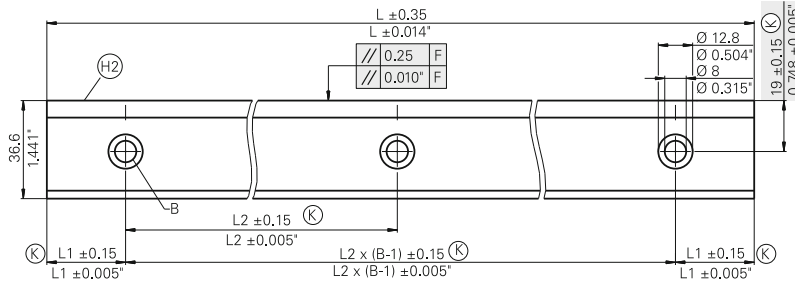

- For ML  $\geq 1675$  mm (65") backup spar included in items supplied
- For ML  $\leq 1675$  mm (65") backup spar optional

B = Number of holes

A variety of mounting conditions can be accommodated.

- The machine configuration determines the brackets required to mount the linear encoder.
- Two typical mounting conditions are shown: flush and offset.
- All fasteners shown on this page are supplied with the encoder hardware.

**Flush surfaces**

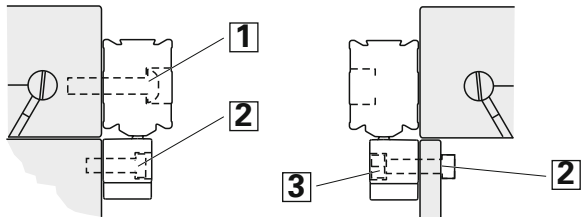

**1** M6 x 25 mm BHCS  
(1/4"-20 x 1" BHCS)  
M6 flat washer

**2** M4 x 25 mm SHCS low head  
(8-32 x 5/8" SHCS low head)  
(8-32 x 3/4" SHCS low head)

- Mounting surfaces are flush within 0.25 mm (0.010").
- The reading head leveling screws are not required.

**Offset surfaces**

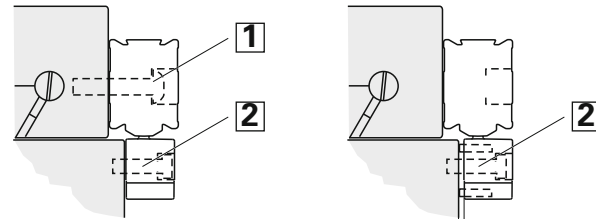

**!** Space of  $\leq 4.5$  mm ( $\leq 0.18$ " ) use reading head leveling screws!

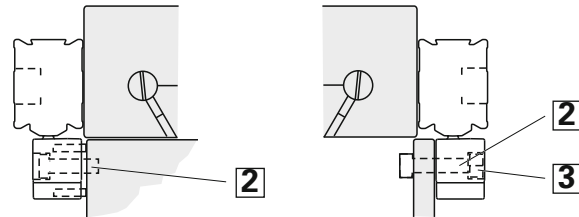

**3** M4 hex nut

- Mounting surfaces are offset.
- Mounting without backup spar.
- Use leveling screws in place of spacers or shims.

Bore hole pattern

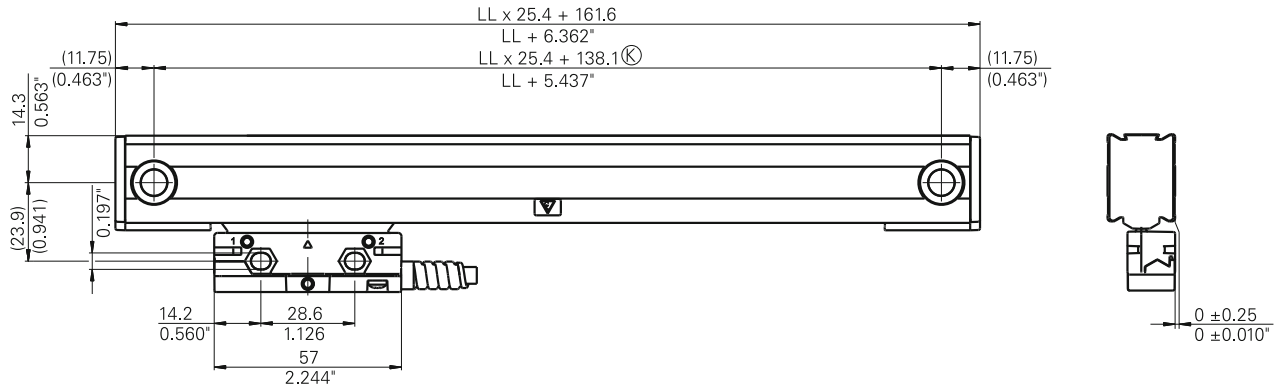

Mounting

- LL < 625 mm (24"): Use end mounting holes.

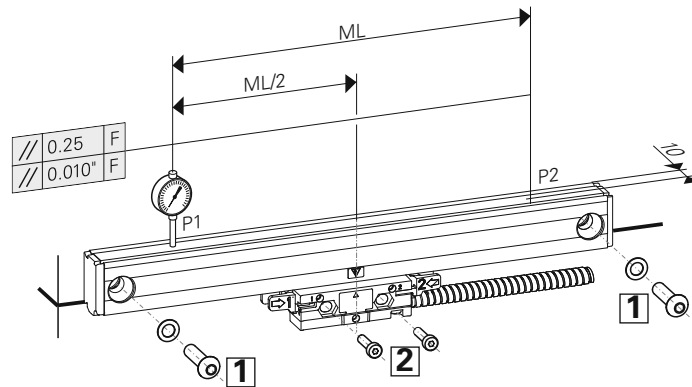

P = Gauging point

**1** M6 x 25 mm  
(1/4"-20 x 1" BHCS)  
M6 flat washer

**2** M4 x 25 mm SHCS low head  
(8-32 x 5/8" SHCS low head)  
(8-32 x 3/4" SHCS low head)

Bore hole pattern

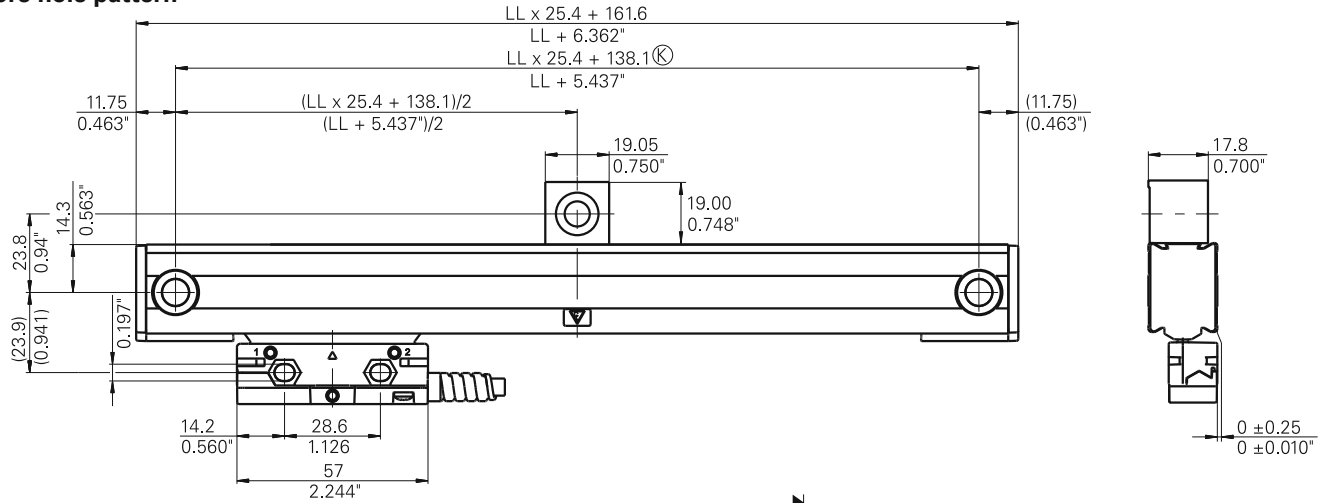

Mounting

- 625 mm (24") ≤ LL ≤ 1550 mm (60"):  
Use end mounting holes with center support.

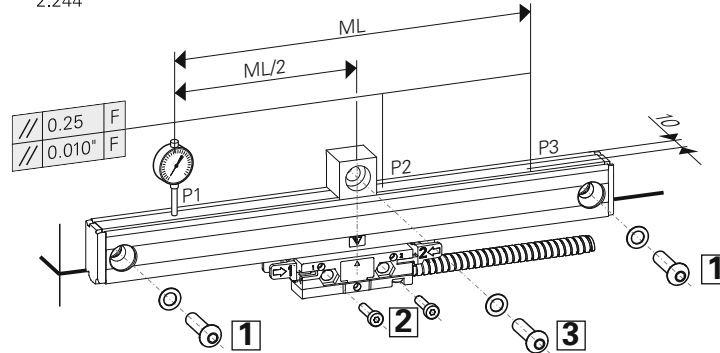

P = Gauging point

- M6 x 25 mm (1/4"-20 x 1" BHCS)  
M6 flat washer
- M4 x 25 mm SHCS low head (8-32 x 5/8" SHCS low head)  
(8-32 x 3/4" SHCS low head)
- M6 x 20 mm (1/4"-20 x 3/4" BHCS)  
M6 flat washer

Mounting possibility

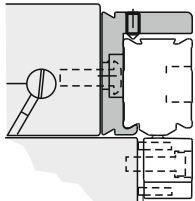

⚠ Space of  $\leq 4.5$  mm ( $\leq 0.18$ " ) use reading head leveling screws!

- Flush or offset mounting with a backup spar.
- Bracket used to reduce head to mounting surface gap.

Mounting

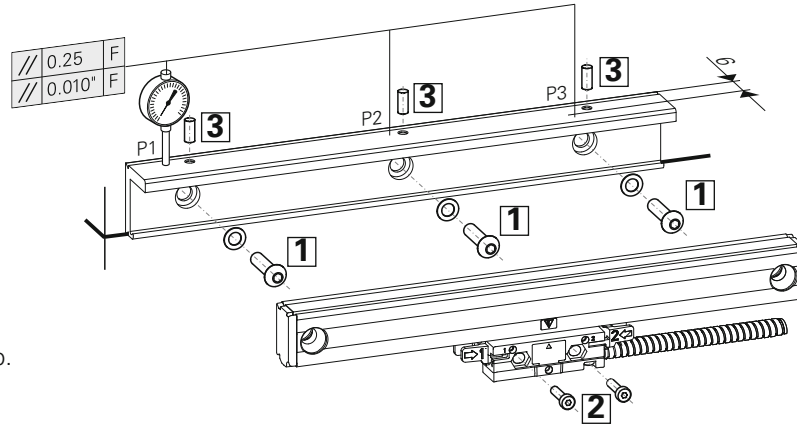

Bore hole pattern

- LL > 1550 mm (60"): A backup spar is required.

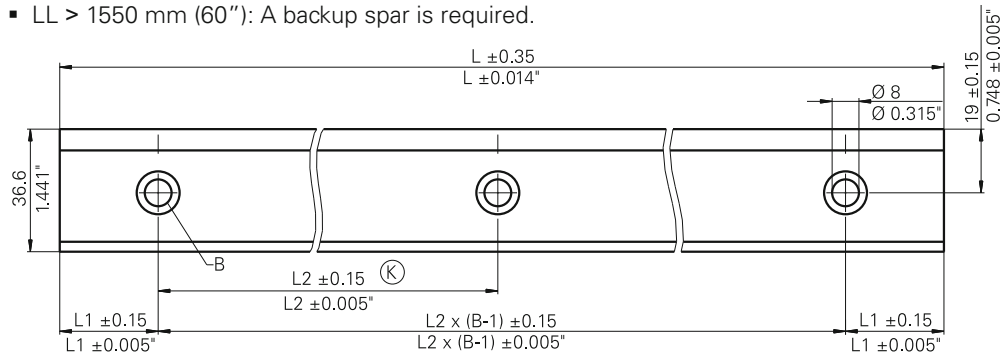

- 1** M6 x 25 mm (1/4"-20 x 1" BHCS)  
M6 flat washer
- 2** M4 x 25 mm SHCS low head (8-32 x 5/8" SHCS low head)  
(8-32 x 3/4" SHCS low head)
- 3** M4 x 8 mm SHSS

P = Gauging point

**Leveling screws**

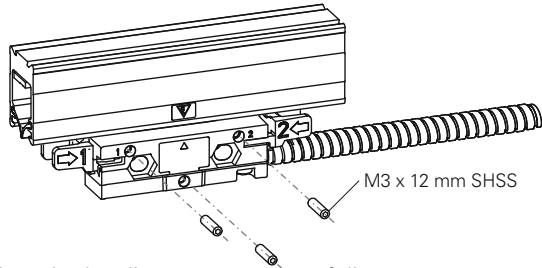

Adjust the leveling set screws as follows:

- Insert, but do not tighten 8-32 (M4) reading head screws as shown on the right side.
- Place a 0.025 mm - 0.075 mm (0.001" - 0.003") shim between the leveling set screws and mounting surface.
- Adjust each set screw until a slight drag is felt on the shim.
- Remove the shim before tighten the reading head screws.

**Mounting the reading head**

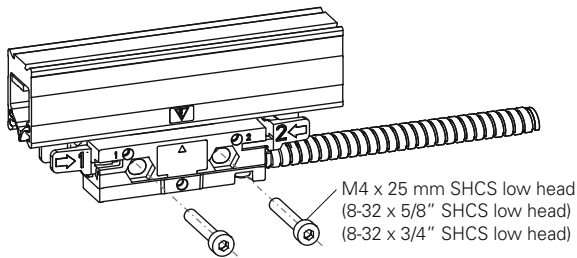

**Mounting the reading head with hex nut**

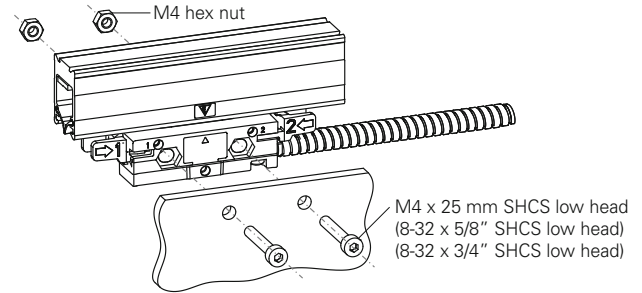

- ⚠ Do not tighten prior to adjusting leveling set screws.
- Evenly tighten the 8-32 (M4) reading head mounting screws.

**Removing the alignment brackets**

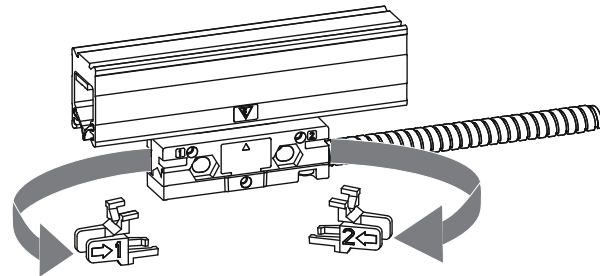

Slide brackets away from reading head and cable.

- Slide the brackets away from the reading head.
- Remove the alignment brackets and save for future use.

### General electrical information

#### Voltage supply

Connect ACU-RITE encoders only to subsequent electronics whose power supply is generated from PELV systems (EN 50 178). ACU-RITE encoders fulfill the requirements of standard IEC 61010-1 only if the power is supplied from a secondary circuit with current limitation as per IEC 61010<sup>3rd Ed.</sup>, Section 9.4 or with power limitation as per IEC 60950-1<sup>2nd Ed.</sup>, Section 2.5 or from a Class 2 secondary circuit as specified in UL1310.<sup>1)</sup>

<sup>1)</sup> In place of IEC 61010-1<sup>3rd Ed.</sup>, Section 9.4, the corresponding sections of standards DIN EN 61010-1, EN61010-1, UL 61010-1 and CAN/CSA-C22.2 No. 61010-1 can be applied and in place of IEC 60950-1<sup>2nd Ed.</sup>, Section 2.5 the corresponding sections of standards DIN EN60950-1, EN60950-1, UL60950-1, CAN/CSA-C22.2 No. 60950-1 can be applied.

#### Connecting the encoder

- Route the cables with slack loops to allow for axis motion.
- Secure excess cable by fastening with clips or ties.
- Attach the linear encoder connectors to the readout.

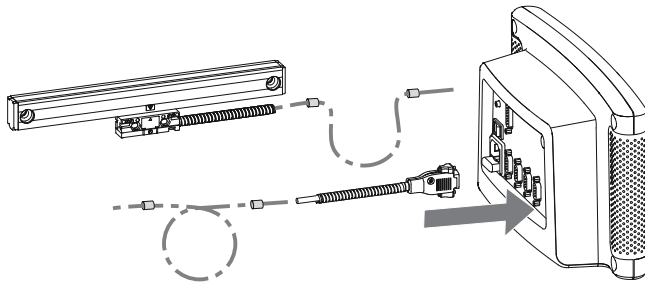

#### Checking the electrical shielding

- Connect a ground wire from the terminal on the back of the readout to the machine or earth ground.
- Attach a ground wire from the machine to a solid earth ground.
- With the encoder attached to the machine and the cable connected to the readout, check shielding by measuring resistance between connector housing and scale unit.

**Desired value: 1 Ω max.**

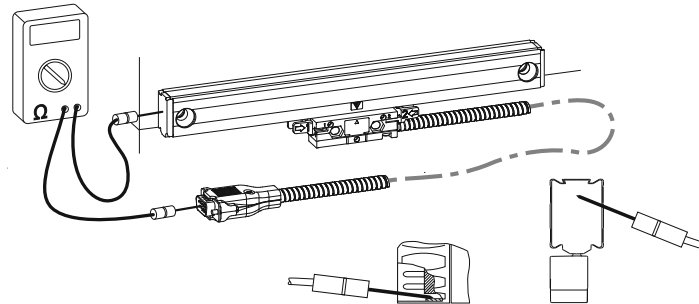



Mechanical specifications	Digital		
Resolution	0.5 μm	1 μm	5 μm
Grating pitch	20 μm		
Scale medium	Glass		
Accuracy (@ 20° C) / 1000 mm	± 3μm, ± 5μm		
Max. traversing speed	60 m/min		
Force required to move reading head	<3.4 N		
Operating environment Temperature Relative humidity	0° to 50° C 25 % to 95 % (non-condensing)		
Storage environment Temperature Humidity	-20° to 70° C 20 % to 95 % (non-condensing)		
Weight w/armor	Scale case: 180 g + 0.65 g/mm ML Reading head: 60 g Backup spar: 1 g/mm L Cable: vinyl: 50 g/m armored: 140 g/m Connector: 55 g		
Connecting cable armored or vinyl	Length = 4 m resp. 6 m from ML 1250 mm; connector: DE-9P		
Max. cable length	≤ 9 m		
Measuring lengths	50 mm – 3075 mm (1"–120")		
Reference pulse interval	Distance coded 50 mm		
Voltage supply	DC 5.1 V ±0.1 V / <220 mA	DC 5.1 V ±0.1 V /< 180 mA	
Protection EN 60529	IP 53 when mounted as per instructions		

10 Pin-outs

11 Output signals

Digital Differential

Pin 1	Pin 2	Pin 3	Pin 4	Pin 5	Pin 6	Pin 7	Pin 8	Pin 9
N/c	Green	Yellow	Blue	Red	White	Brown	Pink	Gray
N/c	Channel A+	Channel A-	Channel B+	Channel B-	Ground	Vcc, +5.1 ±0.1 VDC	Channel R+	Channel R-

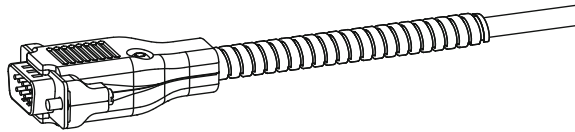
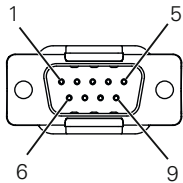

Outout signals

Parameter	Digital
Output signals	<p> <math>I_{OH}</math>=(High level output current) = 20 mA  <math>V_{OH}</math>=(High level output voltage) &gt;2.5 Vdc   <math>I_{OL}</math>=(Low level output current) = -20 mA  <math>V_{OL}</math>=(Low level output voltage) &lt; 0.6 Vdc                 </p> <div style="display: flex; justify-content: space-around;"> <div style="text-align: center;"> <p>Channel A+</p> <p>1 0</p> </div> <div style="text-align: center;"> <p>Channel A-</p> <p>1 0</p> </div> <div style="text-align: center;"> <p>Channel B+</p> <p>1 0</p> </div> <div style="text-align: center;"> <p>Channel B-</p> <p>1 0</p> </div> </div> <p style="text-align: right;">                     Channel R+ 1 0                      Channel R- 1 0                      1 count (phased)                 </p>
Incremental signals	Square-wave voltage signals. Channels A and B, in 90° quadrature relationship
Signal levels	TTL-level
Reference mark signal	Square-wave pulse
Signal level	TTL-level



# HEIDENHAIN

---

**DR. JOHANNES HEIDENHAIN GmbH**

Dr.-Johannes-Heidenhain-Straße 5

**83301 Traunreut, Deutschland**

☎ 08669 31-3121

FAX 08669 32-5061

E-Mail: [service.order@heidenhain.de](mailto:service.order@heidenhain.de)

---

**[service.heidenhain.de](http://service.heidenhain.de)**

---

**HEIDENHAIN CORPORATION**

333 East State Parkway

**Schaumburg, IL 60173-5337, USA**

☎ +1 847 490-1191

FAX +1 847 490-3931

E-mail: [info@heidenhain.com](mailto:info@heidenhain.com)

---

**[www.heidenhain.com](http://www.heidenhain.com)**

**ACU-RITE®**

**ISO 9001  
CERTIFIED**

