

A = Lagerung
Bearing

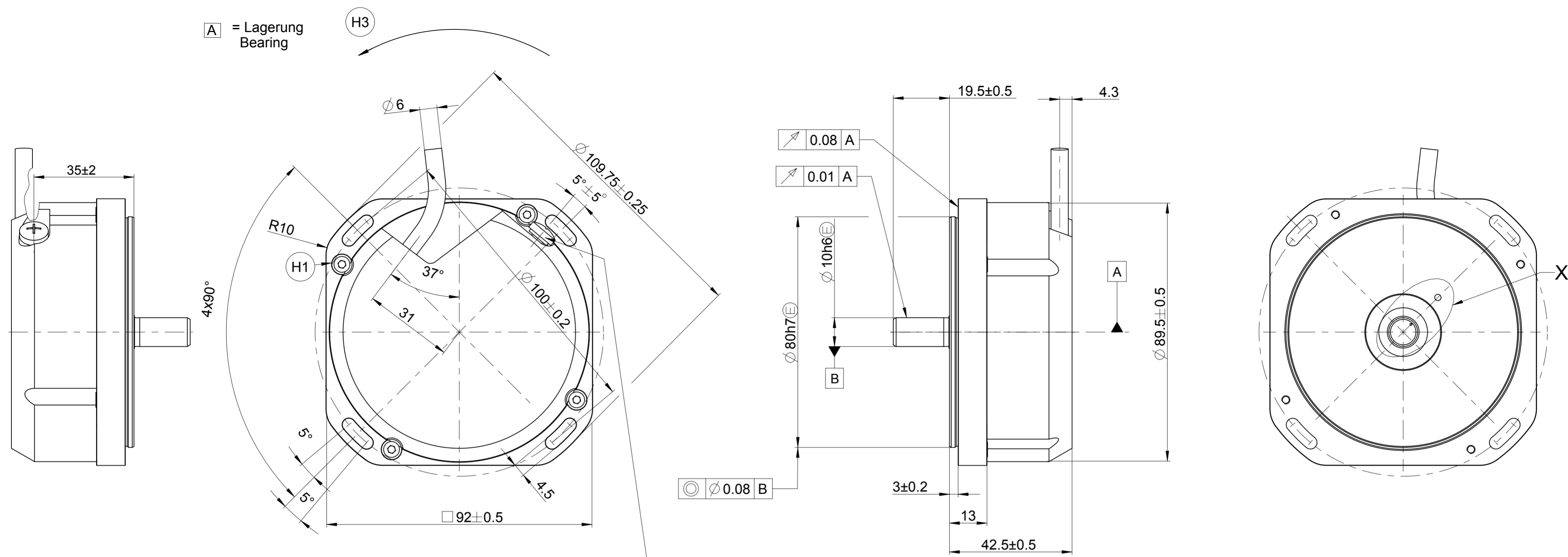

Druckluftanschluss M5
Compressed air connection M5

Lage der Referenzmarke
1, 36 Referenzmarken: ±5°
Position of reference mark
1, 36 reference Marks: ±5°

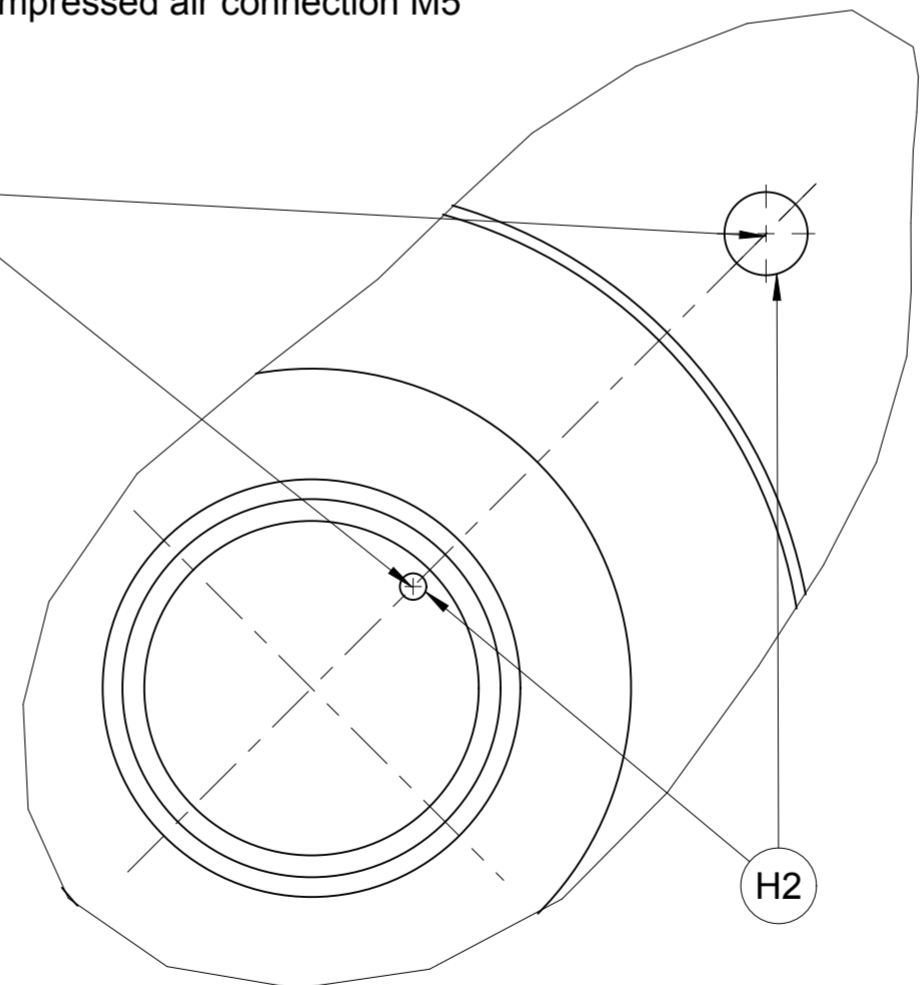

- (H1) - Schraube ISO 4762-A2-M4 und Scheibe ISO 7092-4-200HV-A2
Anziehdrehmoment der Zylinderschraube M4: 2,4±0,2 Nm
Schraubensicherung erforderlich

- Screw: ISO 4762-A2-M4 and Washer: ISO 7092-4-200HV-A2
Tightening torque hexagon socketed head cap screw M4: 2,4 ±0,2Nm
- (H2) - Markierung der Nullposition ±5°
- 0° position index ±5°
- (H3) - Drehrichtung der Welle für Ausgangssignale gemäß Schnittstellen-Beschreibung
- Direction of shaft rotation for output signals as per the interface description

Original drawing			ID number:	
Scale			Release number: N1486	
Format			Tolerierung nach DIN ISO 8015	
Dimensions in mm			Tolerances as per DIN ISO 8015	
1:1	A2	Allgemeintol. ISO 2768-mH ±6mm:±0,2 General tol. ISO 2768-mH ±6mm:±0,2		
The reproduction, distribution and utilization of this document as well as the communication of its contents to others without express authorization is prohibited. Offenders will be held liable for the payment of damages. All rights reserved in the event of the grant of a patent, utility model or design. (ISO 16016)				
HEIDENHAIN DR. JOHANNES HEIDENHAIN GmbH 83301 Traunreut, Germany			Version	Revision
D 507579-05-A-01			Sheet	Page
Document number			1	1

896 200 A2