



HEIDENHAIN



Montageanleitung
Mounting Instructions
Instructions de montage
Istruzioni di montaggio
Instrucciones de montaje

ERP 880

4 Abtaststellen
Four Scanning Positions
4 positions de balayage
4 punti di scansione
Cuatro puntos de palpación

Fusselfreies Papiertuch
Lint-free cloth
Chiffon non pelucheux
Panno di carta
Paños sin pelusa



Aceton
Acetone
Acétone
Acetone
Acetona



SW 3

SW 4

SW 3

SW 4

Drehmomentschlüssel
Torque wrench
Clé dynamométrique
Chiave dinamometrica
Llave dinamométrica

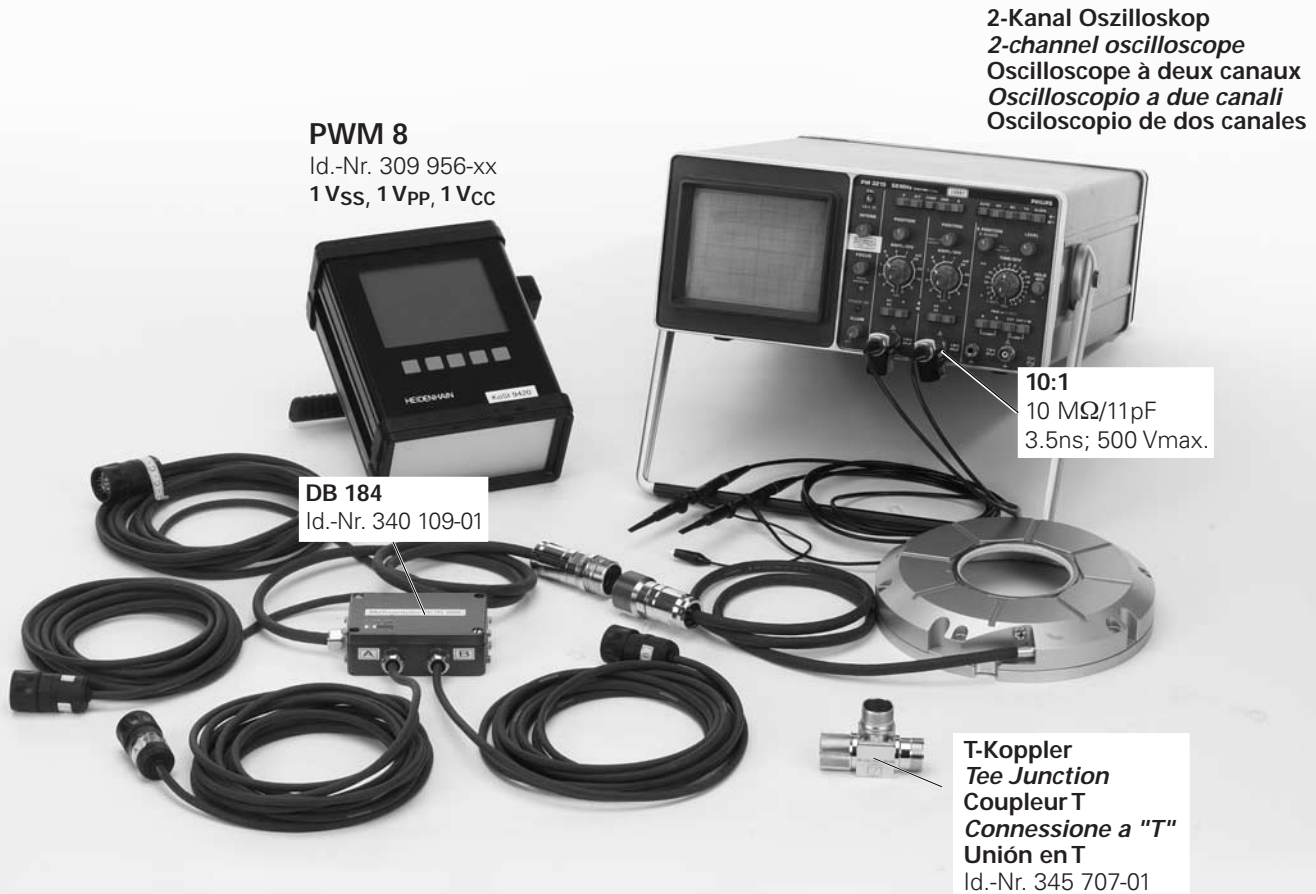

PWM 8
Id.-Nr. 309 956-xx
1 V_{SS}, 1 V_{PP}, 1 V_{CC}

2-Kanal Oszilloskop
2-channel oscilloscope
Oscilloscope à deux canaux
Oscilloscopio a due canali
Osciloscopio de dos canales

DB 184
Id.-Nr. 340 109-01

10:1
10 M Ω /11pF
3.5ns; 500 V_{max}.

T-Koppler
Tee Junction
Coupleur T
Connessione a "T"
Unión en T
Id.-Nr. 345 707-01

Warnhinweise · Warnings · Recommendations · Avvertenze · Advertencias

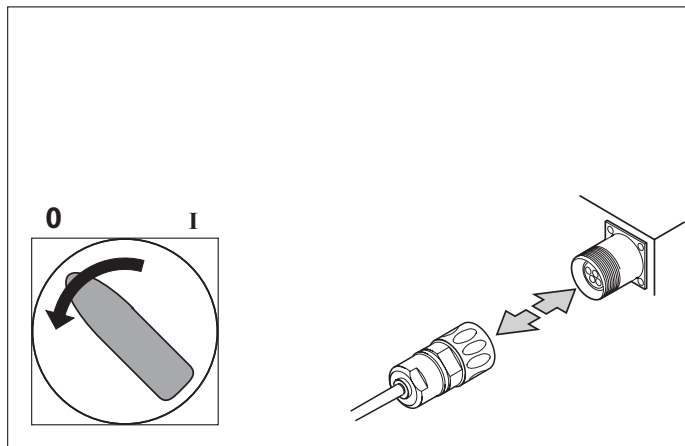
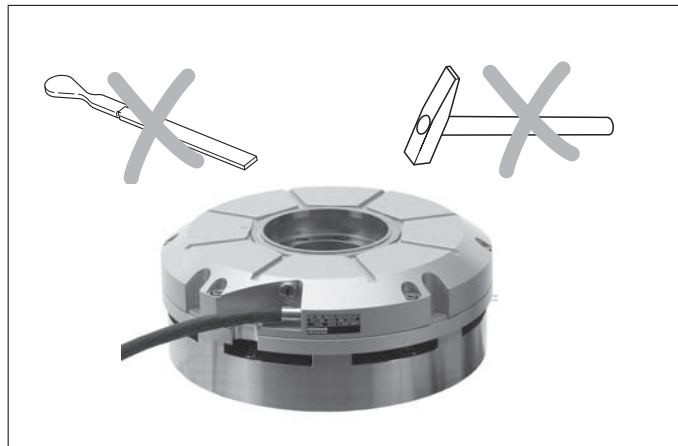
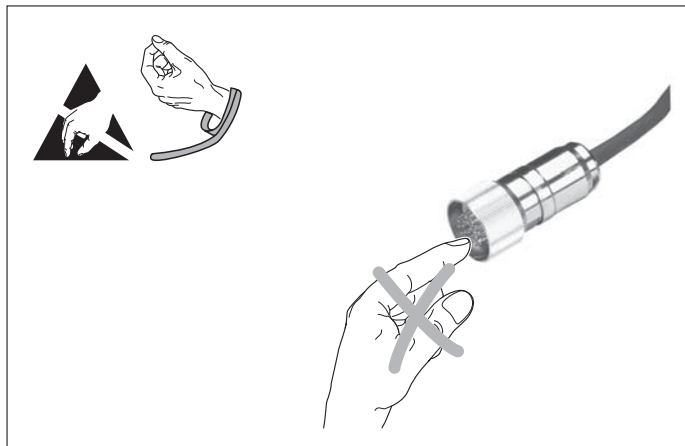

Maße in mm
Dimensions in mm
cotes en mm
dimensioni in mm
dimensiones en mm

Die Meßsystemkomponenten "Teilkreis mit Nabe" und "Abtastring" sind nicht aufeinander abgestimmt und dürfen daher beliebig gepaart werden. Im Servicefalle sind immer die Id.-Nr. und die S.-Nr. anzugeben.

The "grating disk with hub" and "scanning ring" encoder components are not exclusively matched to each other, and can therefore be paired as desired. Always indicate the Id. Nr. and serial number for servicing.

Les éléments du système de mesure "disque gradué avec moyeu" ne sont pas assignés l'un à l'autre. Ils peuvent donc être appariés librement. En cas de service après-vente, il convient toujours d'indiquer la référence (Id.-Nr.) ainsi que le numéro de série (S.-Nr.).

I componenti di misura "disco graduato" e "anello di scansione" possono essere forniti separatamente; in caso di esigenze di assistenza deve sempre essere fornito il numero identificativo (Id. Nr.) e il numero di serie (Sr. Nr.).

Los componentes del sistema de medida "Disco graduado con soporte" y "Anillo palpador" no están sintonizados el uno con el otro, y por tanto pueden aparejarse libremente. En casos de servicio se deben facilitar siempre el número de identidad y el de serie.

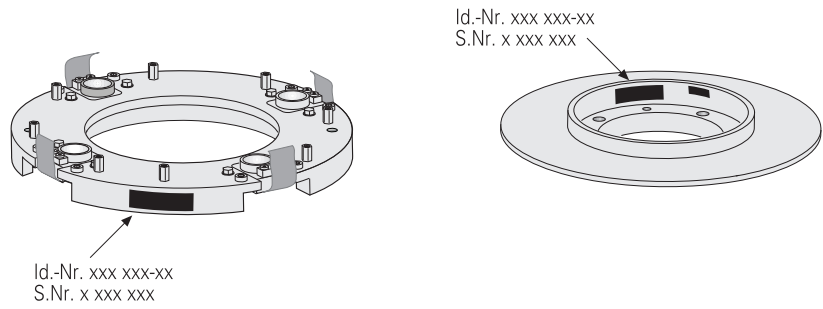



Handschuhe
A pair of gloves
Gants
Guanti
Un par de guantes



Kabelbinder
Cable tie
Collier
Fascetta fissacavo
Unidor de cables



T-Koppler
Tee Junction

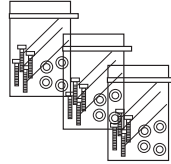

Justierfolien
Spacer foil
Cale d'épaisseur
Distanziali per l'aggiustaggio
Lámina separadora

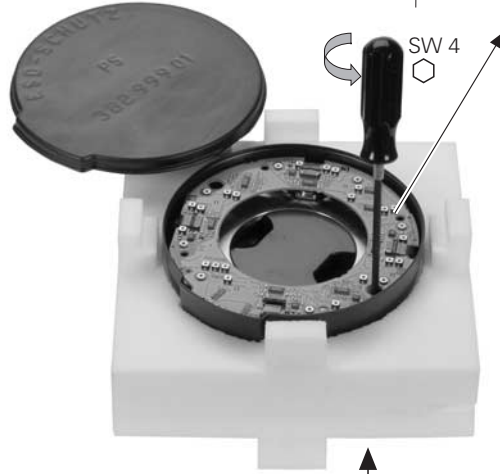
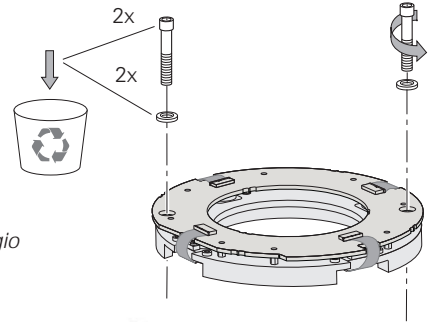

X ↑

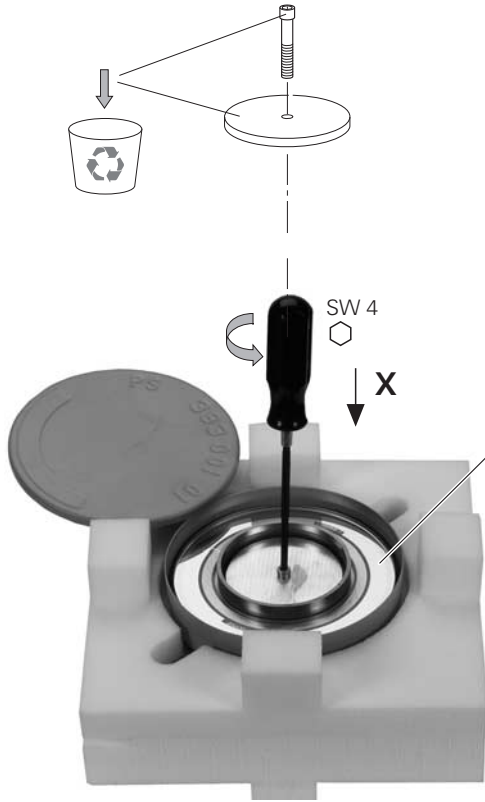

Achtung: Teilkreis nur mit Handschuhen berühren
Please note: Be sure not to touch the grating disk without wearing gloves
Attention: Ne manipuler le disque gradué qu'avec des gants
Attenzione: indossare i guanti per toccare il sistema di misura
Atención: Tocar el disco graduado sólo con los guantes

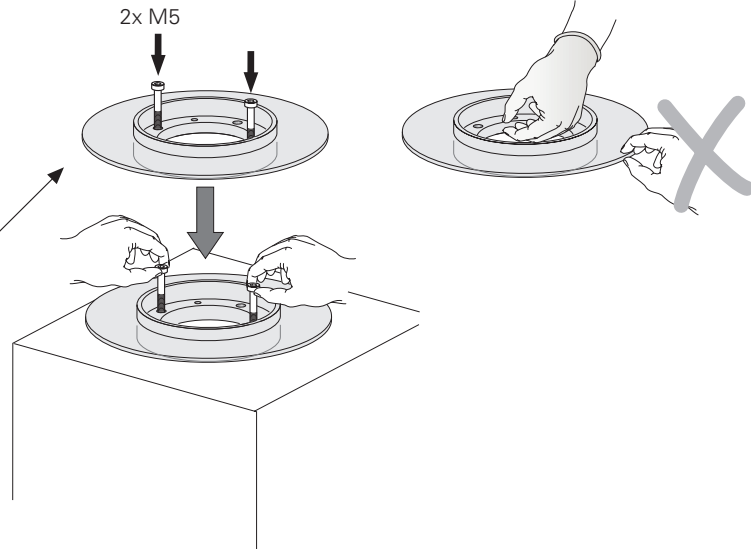

Abmessungen · Dimensions · Dimensions · Dimensioni · Dimensiones

mm



DIN ISO 8015
ISO 2768 - m H

Ⓧ = Dichtring
Sealing ring
Anneau d'étanchéité
Guarnizione a tenuta
Junta anular

Ⓛ = Lagerdrehachse
Axis of bearing rotation
Axe de rotation du montage de l'arbre
Asse di rotazione dei cuscinetti
Eje de rotación de los rodamientos

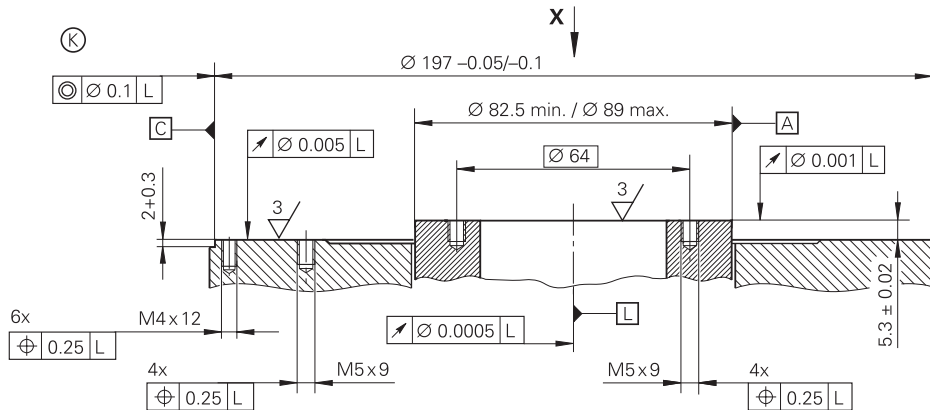
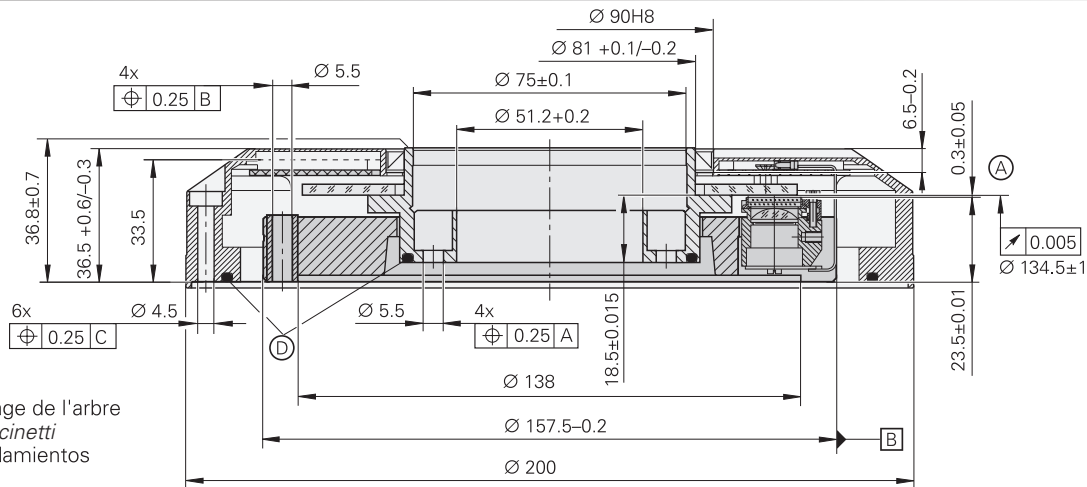

Ⓐ = Abstand Teilscheibe-Abtastplatte
Scale-to-reticle gap
 Distance disque gradué-réticule de balayage
 Distanza tra il reticolo e disco
 Distancia del disco graduado a la pletina de palpación

Ⓚ = Kundenseitige Anschlussmaße
Required mating dimensions
 Encombrement client
 Dimensioni di montaggio richieste
 Dimensiones de conexión requeridas

Ⓕ = Freiraum für Servicefall
Access space for servicing
 Espace libre pour service après-vente
 Zona di servizio per attività di assistenza
 Espacio libre para el caso de servicio

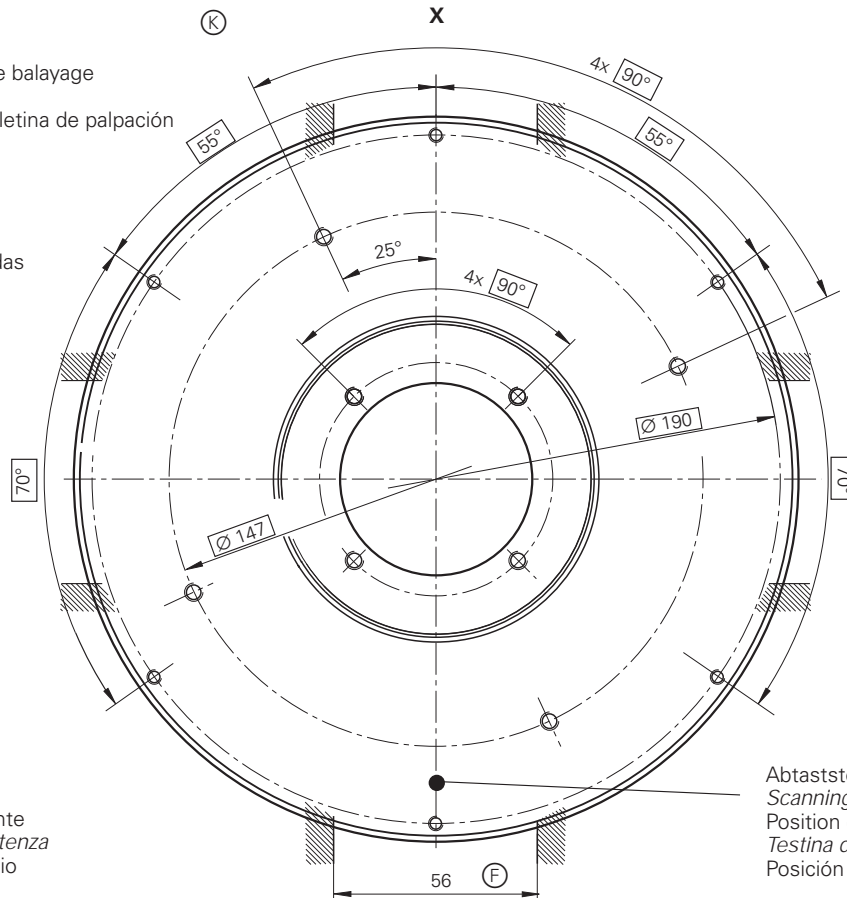

ohne Kappe
Without cover
 Sans capot
Senza coperchio
 Sin cubierta

Referenzmarken-Lage
Reference mark position
 Marque de référence
Indici di riferimento
 Marca de referencia

Platinenoberseite
PCB from above
 Face supérieure de la platine
Scheda vista da sopra
 Parte superior de la pletina

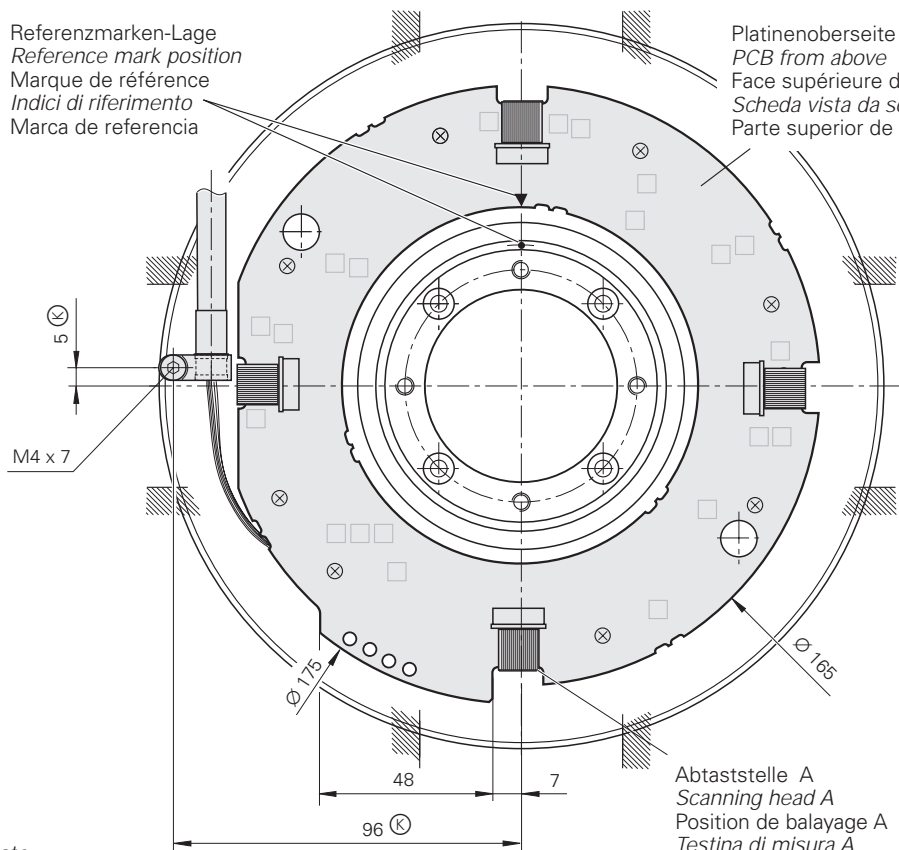

Ⓚ = Kundenseitige Anschlussmaße
Required mating dimensions
 Encombrement client
Dimensioni di montaggio richieste
 Dimensiones de conexión requeridas

Abtaststelle A
Scanning head A
 Position de balayage A
Testina di misura A
 Posición de palpación A



1.

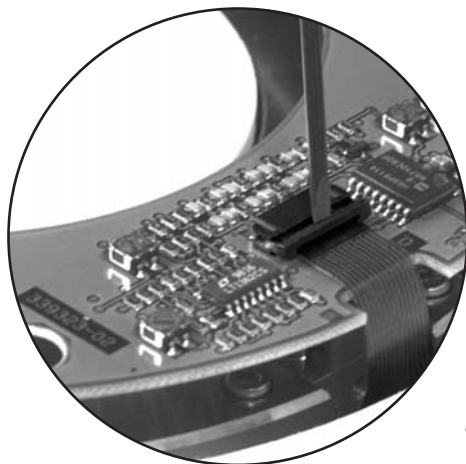

2.

4x

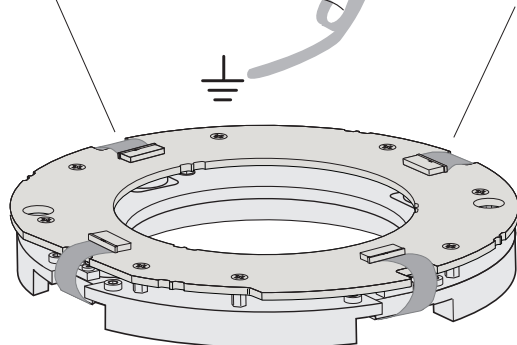
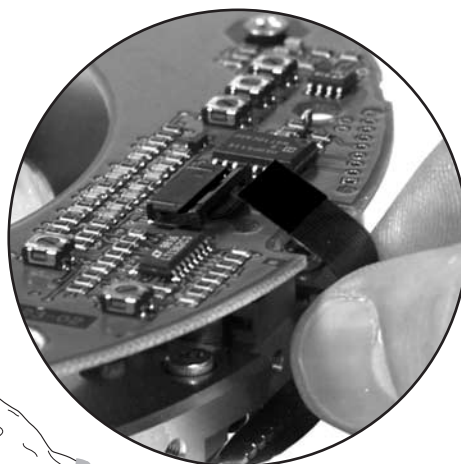

3.

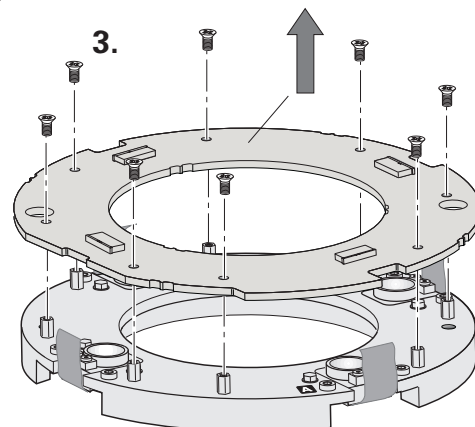

Montaggio della testina di scansione · Montaje de la unidad de captación

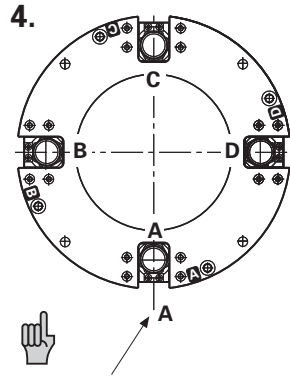

Referenzsignal wird an dieser Stelle ausgegeben.
Der Maschine zugeordnet montieren!

Reference signal is generated by A-scanning head.
Align A-scanning head with desired reference position of axis!

Le **signal de référence** est généré à cet endroit
Aligner la tête captrice A sur la position de référence désirée!

Il segnale di riferimento viene generato nel punto A.
Orientare la testina di lettura nella posizione desiderata

La **señal de referencia** se genera en esta posición.
¡Alinear la cabeza captadora A con la posición de referencia del eje deseada!



5. Montageflächen mit fusselfreiem Papiertuch und Aceton reinigen
Clean with lint-free cloth and acetone
Nettoyer les surfaces de montage avec un chiffon non pelucheux et de l'acétone
Pulire con panno carta e acetone
Limpiar las superficies de montaje con paños libres de pelusa y con acetona.

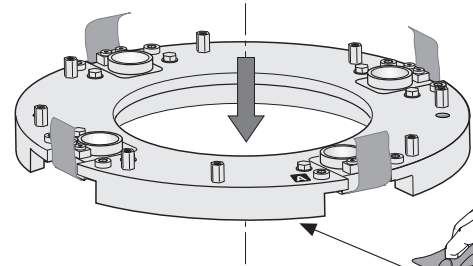

6.
4x
M5 x 25 ISO 4762
SW4

4x DIN 137-AS-A2

M_d = ca. 0.5 Nm

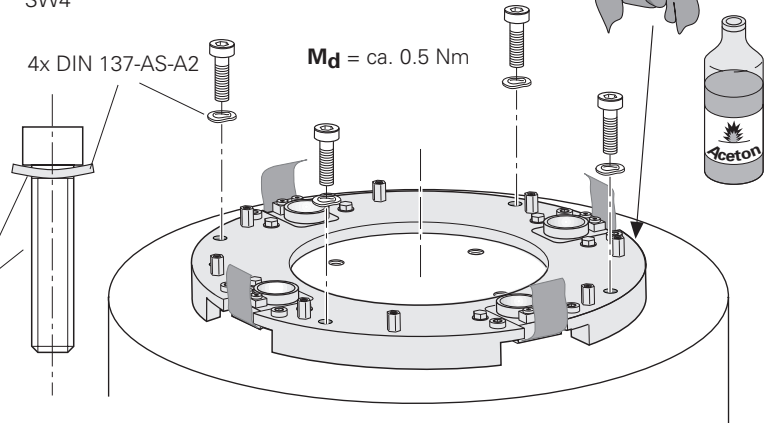

7.

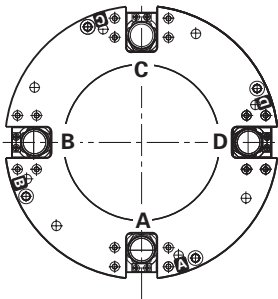

A, B, C, D = Meßpunkte
Measuring points
Points de mesure
Punti di misura
Puntos de medición

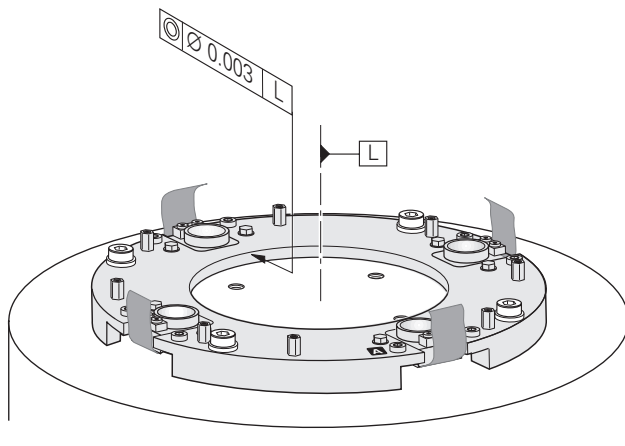
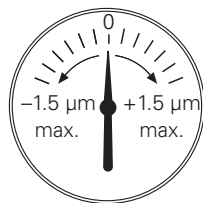

Montaggio della testina di scansione · Montaje de la unidad de captación

Schrauben in sehr kleinen Schritten über kreuz anziehen, bis 2 Nm je Schraube erreicht ist.
Nach jedem Erhöhen des Drehmomentes die Exzentrizität erneut prüfen!

*Tighten screws in an alternating pattern (top and bottom; left and right) in small steps up to 2 Nm torque.
Check eccentricity after each step.*

Serrer les vis progressivement, en bas et en haut, à gauche et à droite jusqu'à obtenir 2 Nm par vis.
A chaque augmentation du couple, vérifier l'excentricité!

*Stringere le viti alternatamente (sopra, sotto, sinistra, destra) con piccoli incrementi di coppia di 2 Nm.
Verificare l'eccentricità ad ogni passo.*

Atornillar en muy pequeños pasos en cruz (encima y abajo, izquierda y derecha), hasta alcanzar los 2 Nm en cada tornillo.
¡Verificar la excentricidad tras cada paso de aumento del par!

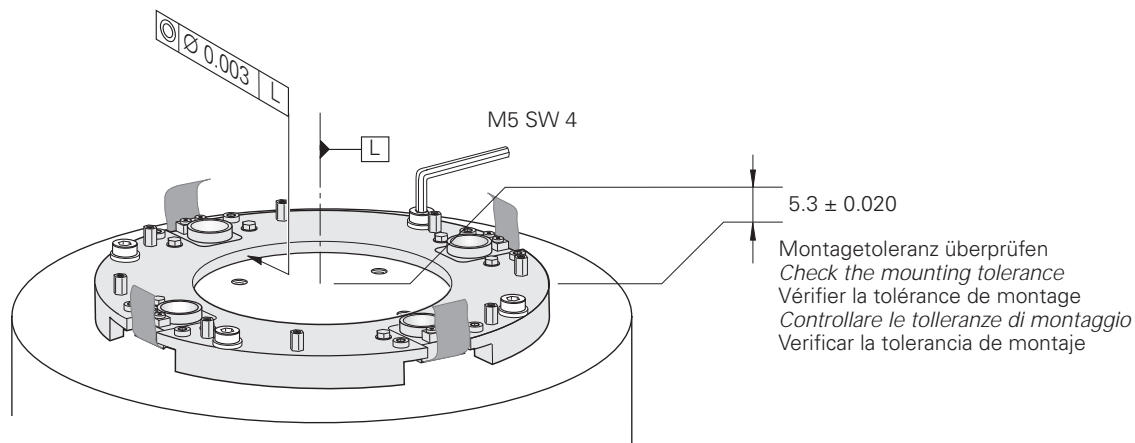

Montage des Teilkreis mit Nabe · *Mounting the hub assembly* · Montage du disque gradué avec moyeu

Montageflächen mit fussselfreiem Papiertuch und Aceton reinigen.
(Bei Bedarf Teilkreisunterseite von innen nach außen mit fussselfreiem Papiertuch und Aceton reinigen.)

*Clean the mounting surfaces with lint-free cloth and acetone.
(If necessary, clean the lower side of the grating disk from the inside out with lint-free cloth and acetone)*

Nettoyer les surfaces de montage avec un chiffon non pelucheux et de l'acétone.
(Si nécessaire, nettoyer la face inférieure du disque gradué de l'intérieur vers l'extérieur avec un chiffon non pelucheux et de l'acétone).

*Pulire le superfici di montaggio con panno carta e acetone, con movimenti dall'interno all'esterno.
(Se necessario, pulire anche la parte inferiore del disco con movimenti dall'interno all'esterno)*

Limpiar las superficies de montaje con paños libres de pelusa y con acetona.
(En caso necesario, limpiar la parte inferior del disco graduado desde el interior hacia el exterior con un paño libre de pelusa y acetona).

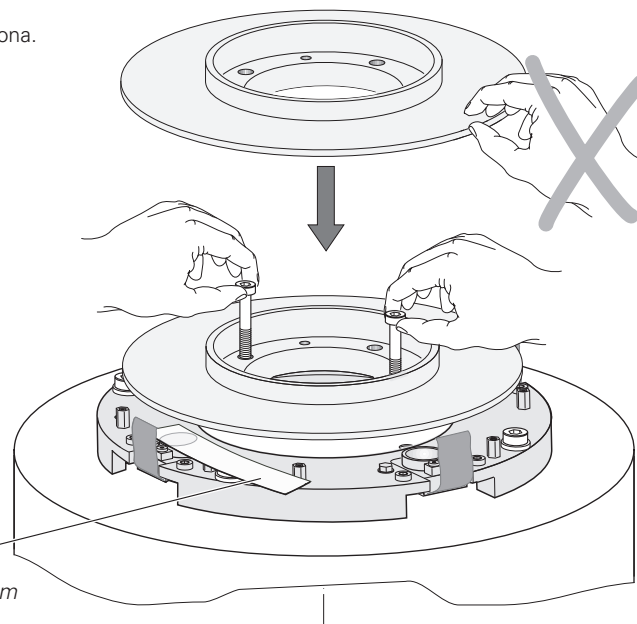
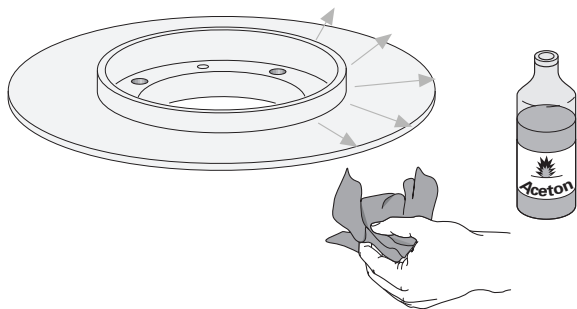

Folie 0.3 mm
Foil 0.3 mm
Cale 0.3 mm
Distanziale 0.3 mm
Lámina 0.3 mm

Montaggio disco graduato · Montaje del disco graduado con soporte

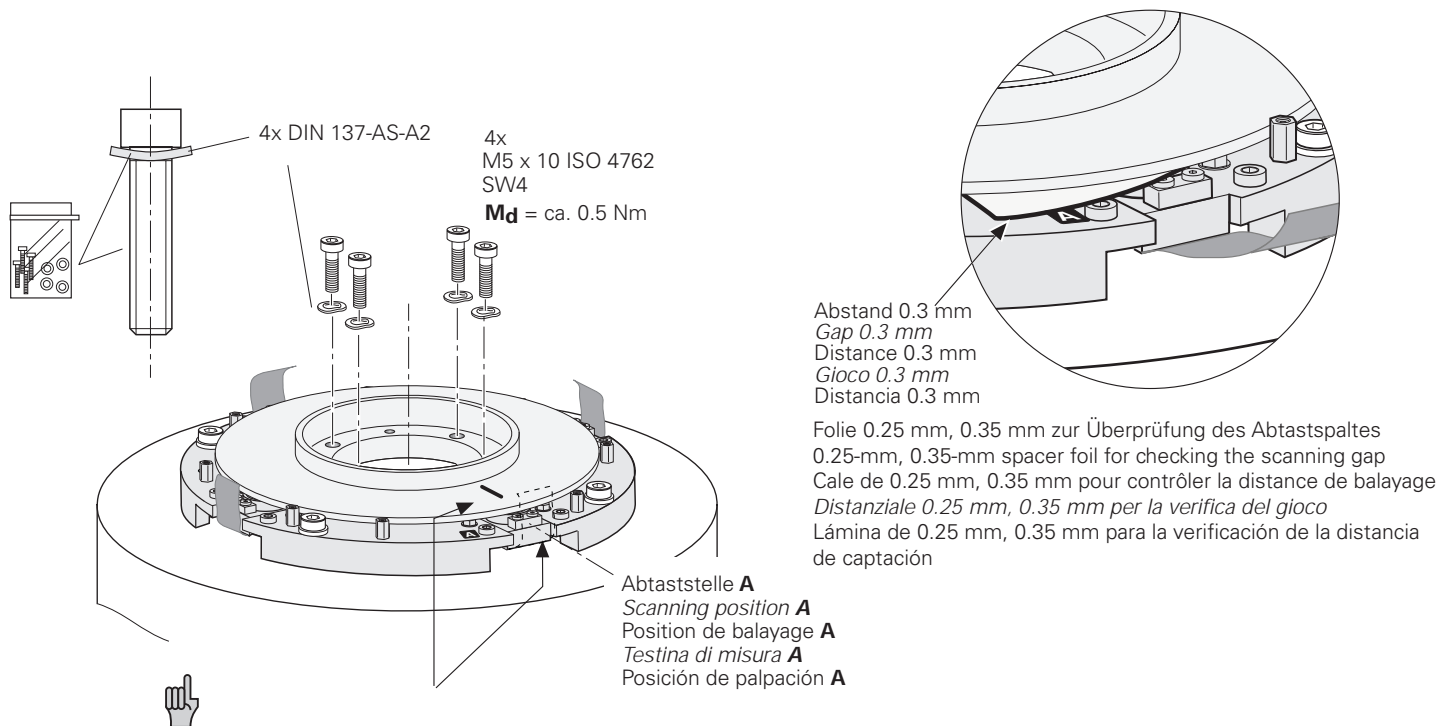

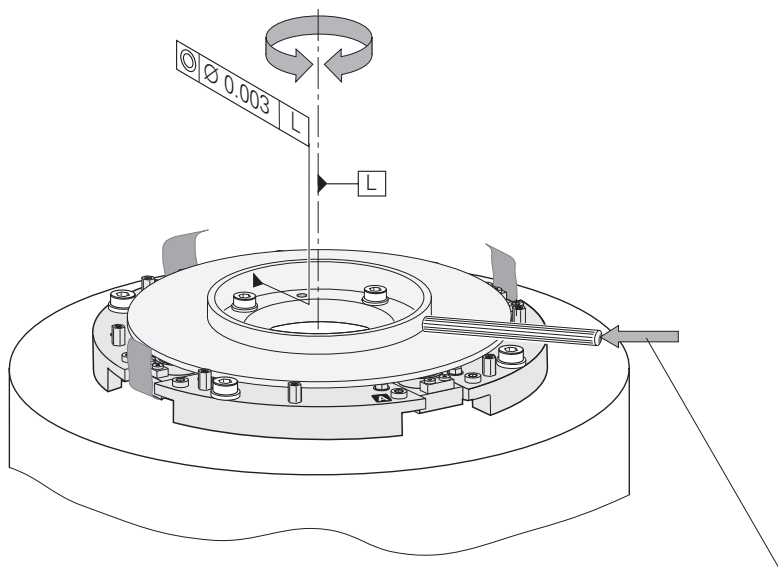

Leicht klopfen, bis Zentrierwert erreicht ist. Kein metallisches Zentrierwerkzeug verwenden.

Tap lightly until required centricity is achieved (non-metallic adjustment tool).

Tapoter légèrement jusqu'à ce que la valeur de centrage soit atteinte. Ne pas utiliser d'outil de centrage métallique.

Tramite piccoli colpi (non usare attrezzi metallici) raggiungere il valore di precentraggio richiesto.

Golpear ligeramente hasta que se alcance el valor de centrado. No utilizar ninguna herramienta de centrado metálica.

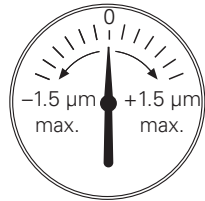

maximale Exzentrizität
Maximum eccentricity
Excentricité maximale
Eccentricità massima
Excentricidad máxima



1.



Auf die Lage der Platine achten
Align PCB to scanning ring
Faire attention à la position de la platine
Attenzione alla posizione della scheda
Alinear la pletina con respecto al anillo

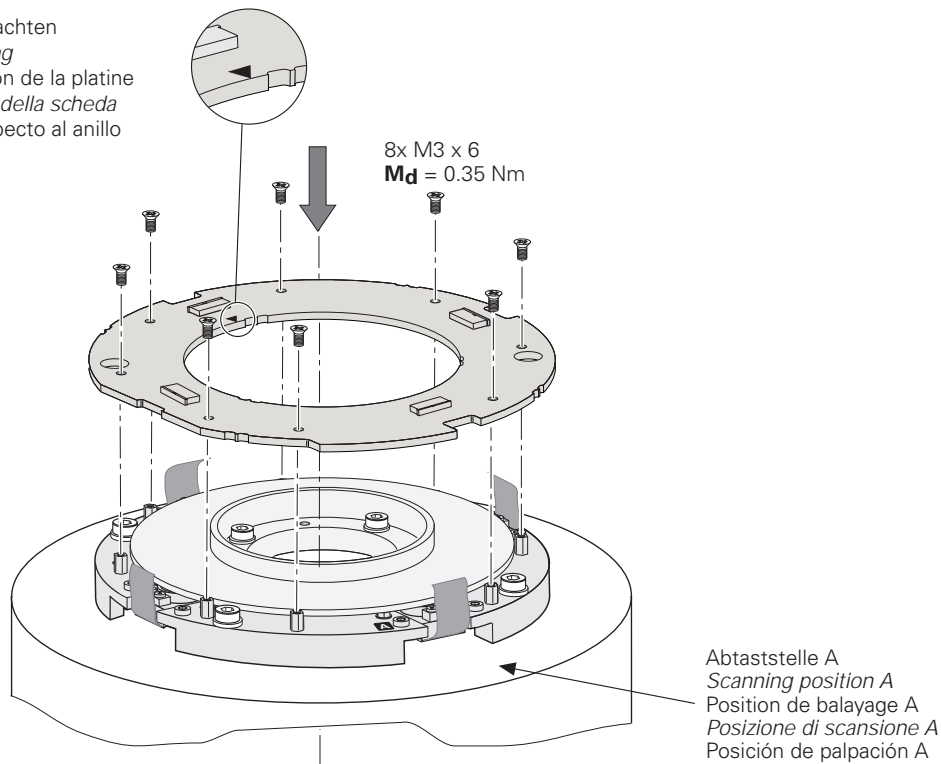

- 2.** Flexleiter bis Anschlag einstecken (nicht knicken). Stecker schließen um Flexleiter zu verriegeln.
Insert flex strips into connectors on the PCB (do not fold or deform the flex strips). Close connector to lock flex strips in place.
insérer les conducteurs flexibles jusqu'en butée (ne pas couder). Fermer le connecteur pour verrouiller les conducteurs flexibles.
Inserire il cavo flessibile nell'apposito connettore sulla scheda PCB (non deformare il cavo). Chiudere il connettore per fissare il cavo.
Insertar las bandas flexibles en los conectores de la pletina (no doblarlos). Cierre el conector para mantener las bandas flexibles en su sitio.

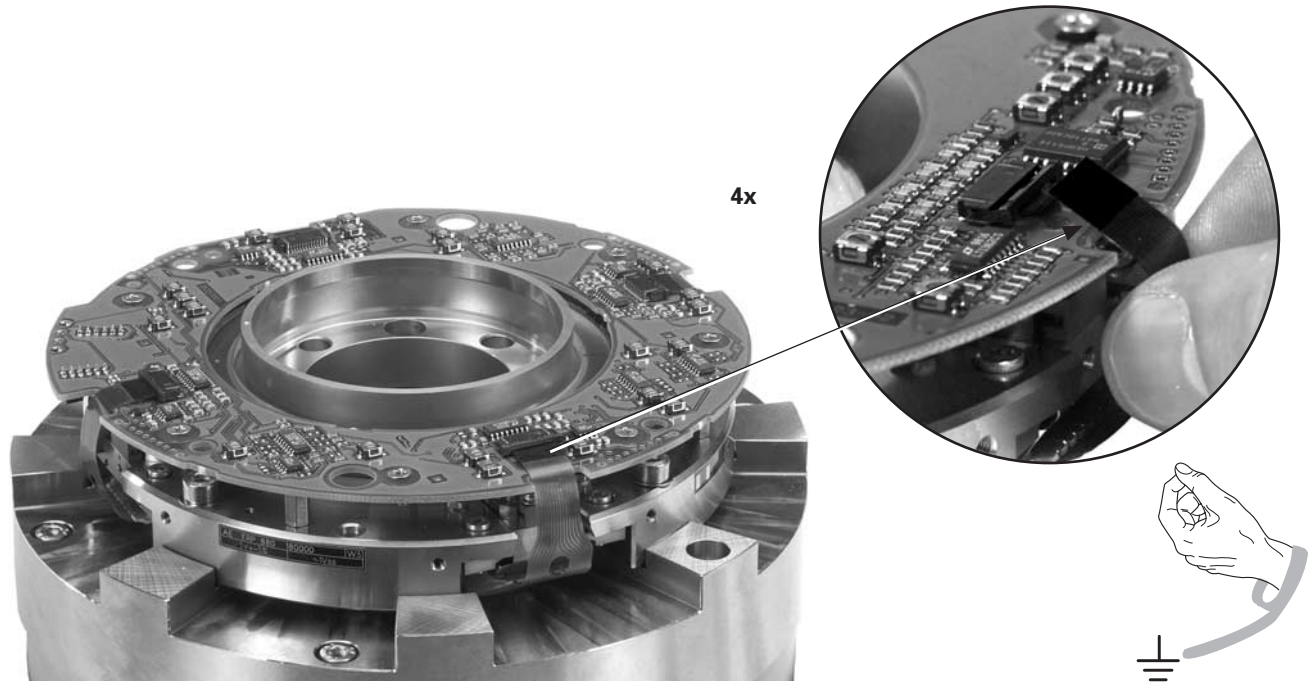

1.

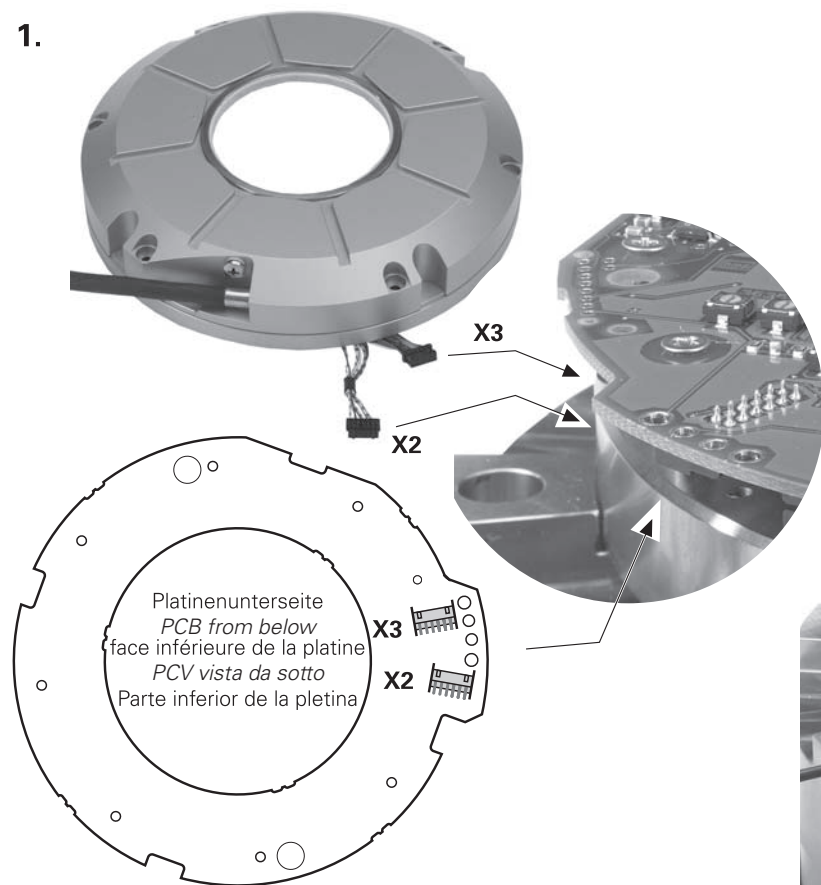

2.

Platinenoberseite
PCB from above
face supérieure de la platine
Scheda vista da sopra
Parte superior de la pletina

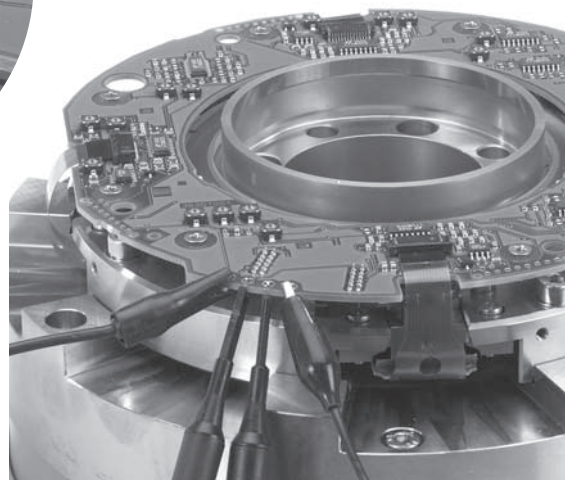
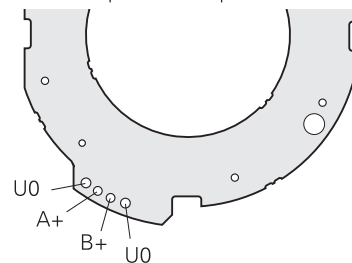

PWM 8

Id.-Nr. 309 956-xx

1 V_{SS}, 1 V_{PP}, 1 V_{CC}

T-Koppler
Tee Junction
Coupleur T
Connessione a "T"
Unión en T

Id.-Nr. 345 707-01

A+
Trigger

B+

2-Kanal Oszilloskop
2-channel oscilloscope
Oscilloscope à deux canaux
Oscilloscopio a due canali
Osciloscopio de dos canales

10:1

10 M Ω /11 pF
3.5ns; 500 Vmax.



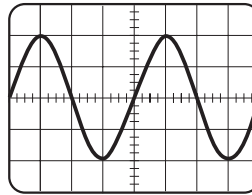
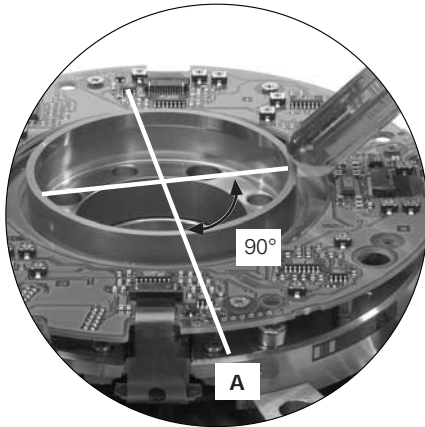
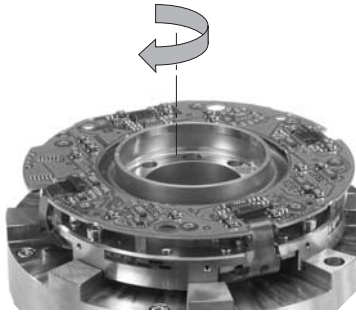

Nur A+ (Trigger)
 Only A+ (Trigger)
 A+ seulement (trigger)
 Solo A (trigger)
 Sólo A+ (Trigger)

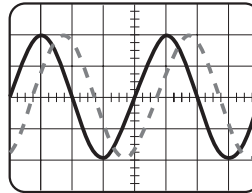

— A+ (Trigger)
 B+ wandert
 B+ moves
 - - - B+ bouge
 B+ si muove
 B+ se mueve

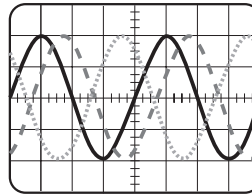

Position von B+ ganz links
 Position of B+ at far left
 Position de B+ tout à gauche
 Posizione B+ all'estrema sinistra
 Posición de B+ en el extremo izquierdo

Position von B+ ganz rechts (In dieser Position klopfen, wie im Bild dargestellt)
 Position of B+ at far right (Tap lightly in this position as illustrated)

- - - Position de B+ tout à droite (à cette position, tapoter comme indiqué sur la figure)
 Posizione b+ all'estrema destra (picchiattare come mostra in figura pag. precedente)
 Posición de B+ en el extremo derecho (golpear en esta posición, como se muestra en el dibujo)

Die extremen Lagen des B+ Signales ergeben den Fehler durch verbleibende Restexzentrizität des Teilkreises $7.2'' \triangleq 360^\circ$ elektrisch (φ max. = 90° ele. $\triangleq 1.4'' \dots 1.8''$ sollte erreicht werden.)

The extreme positions of the B+ signals determine the error through the residual eccentricity of the grating disk. $7.2'' \triangleq 360^\circ$ electrical (φ max. = 90° elec. $\triangleq 1.4'' \dots 1.8''$ should be attained.)

Les positions extrêmes du signal B+ détermine l'erreur par l'excentricité résiduelle du disque gradué $7.2'' \triangleq 360^\circ$ élect. (φ max. = 90° elect. $\triangleq 1.4'' \dots 1.8''$ devrait être atteint.)

Le posizioni estreme del segnale B+ determinano un errore proporzionale all' eccentricità residua del disco graduato. Elettrici (φ max. = 90° elettrici $\triangleq 1.4'' \dots 1.8''$ dovrebbe essere raggiungibile)

Las posiciones extremas de las señales B+ determinan el error debido a la excentricidad residual del disco graduado. $7.2'' \triangleq 360^\circ$ eléctricos (φ máx = 90° eléc. $\triangleq 1.4'' \dots 1.8''$ se debería alcanzar.)

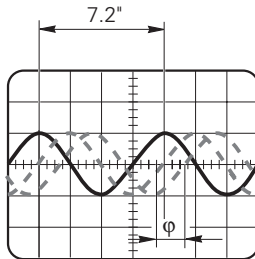

Schrauben in sehr kleinen Schritten über kreuz anziehen, bis 2 Nm je Schraube erreicht ist.
Nach jedem Erhöhen des Drehmomentes die Exzentrizität erneut prüfen!

*Tighten screws in an alternating pattern (top and bottom; left and right) in small steps up to 2 Nm torque.
Verify eccentricity after each step.*

Serrer les vis progressivement, en bas et en haut, à gauche et à droite jusqu'à obtenir 2 Nm par vis.
A chaque augmentation du couple, vérifier l'excentricité!

*Stringere le viti alternativamente (sopra, sotto, destra, sinistra) a piccoli incrementi di 2 Nm.
Verificare l'eccentricità dopo ogni passo.*

Atornillar en muy pequeños pasos en cruz (encima y abajo, izquierda y derecha), hasta alcanzar los 2 Nm en cada tornillo.
¡Verificar la excentricidad tras cada paso de aumento del par!





Test e taratura dei segnali d'uscita · Verificación y ajuste de las señales de salida

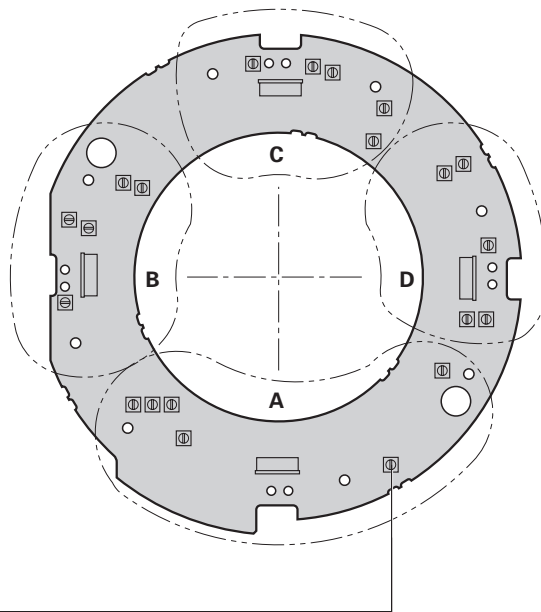
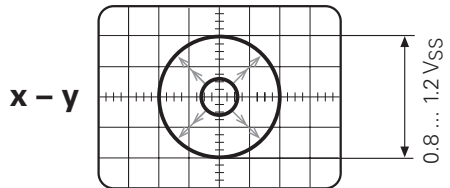
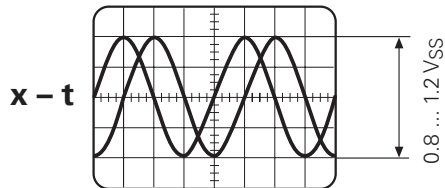
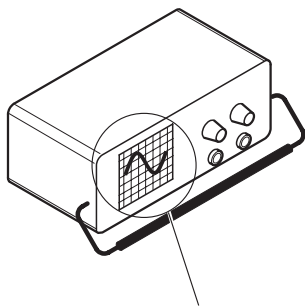

Signalamplitude 0° und 90°
Signal amplitude 0° and 90°
Amplitude du signal 0° et 90°
Ampiezza del segnale 0° e 90°
Amplitud de señal 0° y 90°

PWM 8 auf MODE-AMPLITUDE MESSEN

Set the PWM 8 to MODE-AMPLITUDE MEASUREMENT

Mettre le PWM 8 sur MESURER AMPLITUDE MODE

Settare il PWM8 a MODE AMPLITUDE MEASUREMENT

Ajustar el PWM 8 a MEDICION MODE-AMPLITUDE

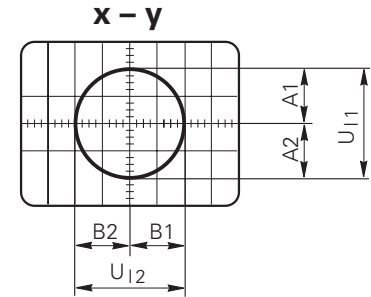
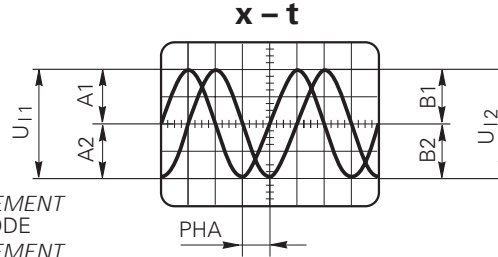
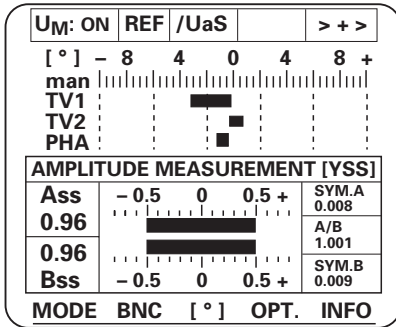
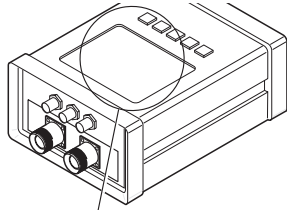

U ₁₁ , U ₁₂	1 V ± 10%	
$\frac{U_{11}}{U_{12}}$	0.98 ... 1.02	$\frac{Ass}{Bss}$ 0.98 ... 1.02
TV1	$\frac{ A1 - A2 }{2U_{11}} < 0.017$	± 4°
TV2	$\frac{ B1 - B2 }{2U_{12}} < 0.017$	± 4°
PHA	90° ± 2°	90° ± 2°

U₁₁, U₁₂: Amplituden der Inkrementalsignale
Amplitudes of the incremental signals
 Amplitudes des signaux incrémentaux
Ampiezza dei segnali incrementali
 Amplitudes de las señales incrementales

$\frac{U_{11}}{U_{12}}$: Amplitudenverhältnis
Amplitude ratio
 Rapport d'amplitude
Rapporto ampiezze
 Relación de amplitudes

TV1, TV2: Symmetrieabweichungen
Unbalance
 Ecarts de symétrie
Bilanciamento
 Desviaciones de la simetría

PHA: Phasenwinkel
Phase angle
 Angle de phase
Angolo di fase
 Ángulo de fase

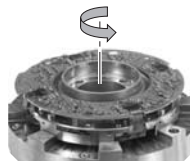
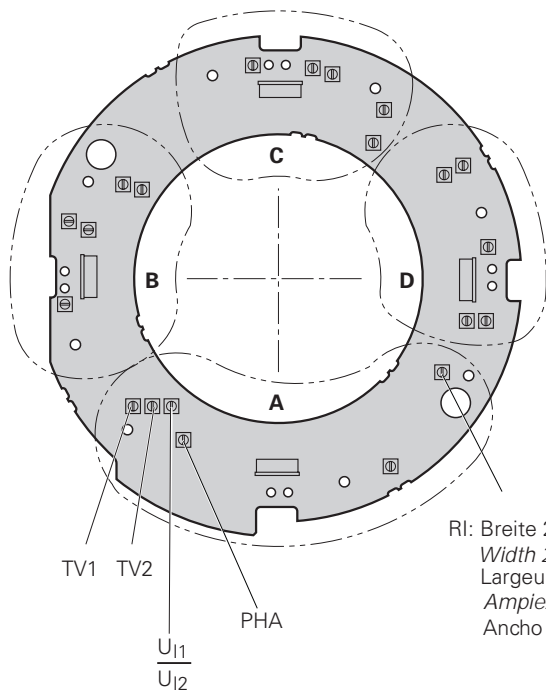

getriggert auf RI
 Triggered on RP
 Déclenché sur RI
 Triggered su RP
 Hecho el trigger en RI

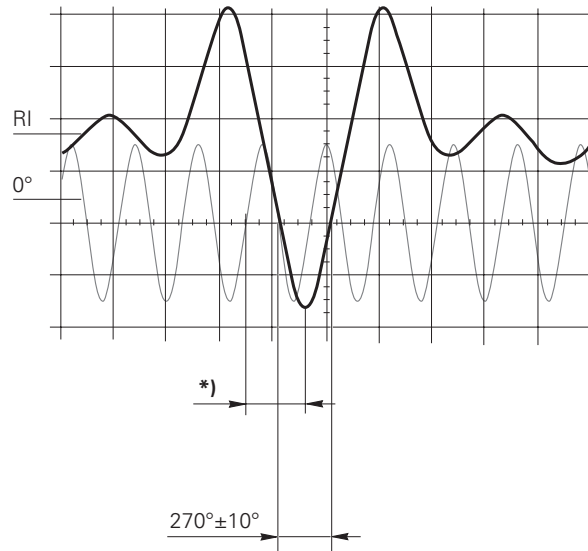

RI: Breite 270° ± 10° ele.
 Width 270° ± 10° elec.
 Largeur 270° ± 10° élect.
 Ampiezza 270° ...
 Ancho 270° ± 10° electr.

- *) RI-Lage 315° ± 45° (nicht einstellbar) überprüfen
 Ensure that the RP position is 315° ± 45° (not adjustable)
 Vérifier la position de l'impulsion de réf. RI 315° ± 45° (non réglable)
 Controllare posizione RP (non regolabile)
 Verificar la posición RI 315° ± 45° (no ajustable)





Kabelausgang ausrichten
Align cable exit
Aligner la sortie du câble
Allineare l'uscita del cavo
Alinear la salida del cable

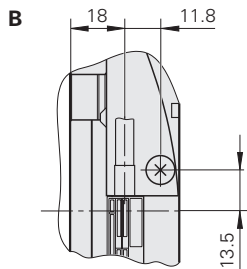
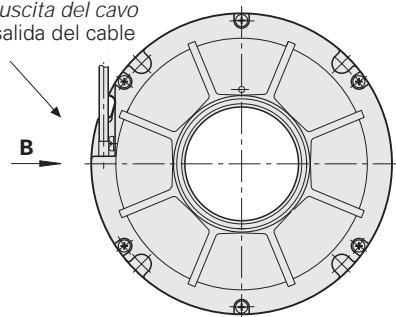



Abtaststelle **A**
Scanning position A
Position de balayage **A**
Posizione di scansione A
Posición de palpación **A**

Druckluftanschluß
Compressed air inlet
Raccordement d'air comprimé
Connessione aria pressurizzata
Conexión de aire comprimido

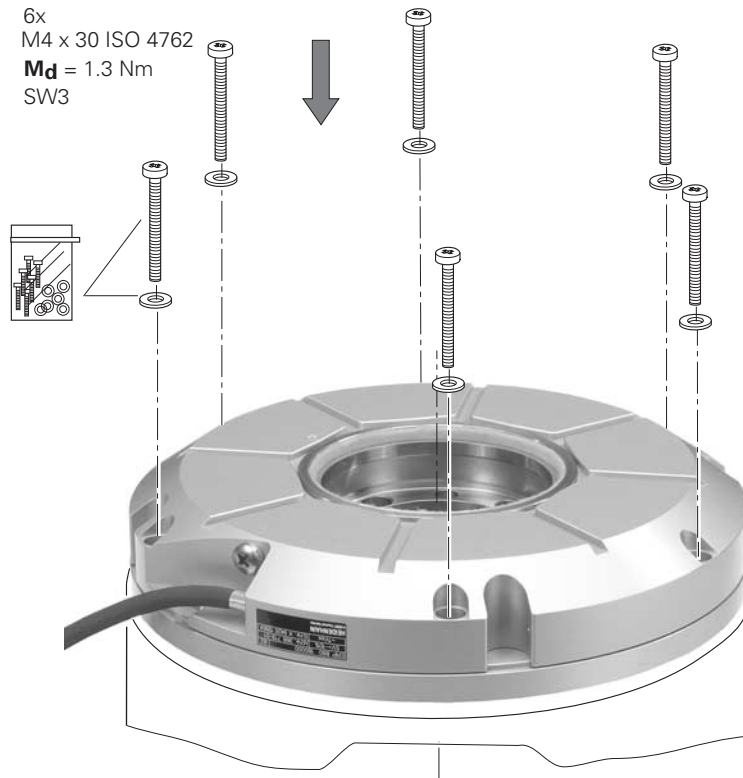
6x
M4 x 30 ISO 4762
M_d = 1.3 Nm
SW3

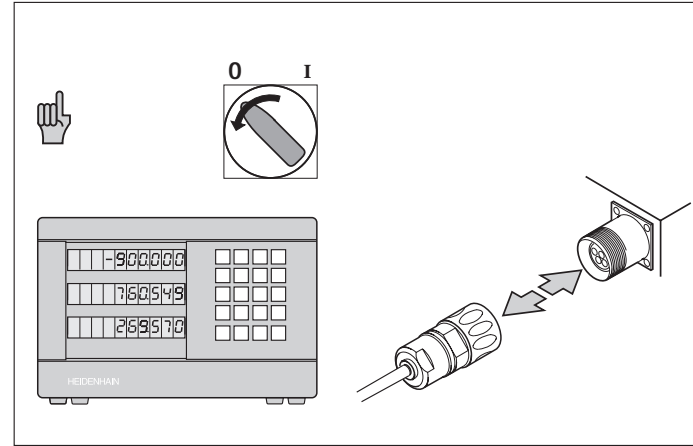
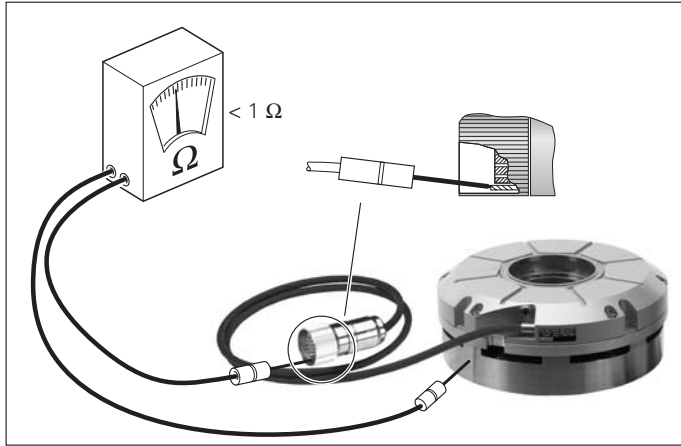

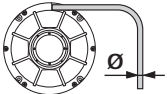

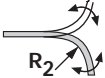
	 <p>$T \geq -40\text{ °C}$ (-40 °F)</p>	 <p>$T \geq -10\text{ °C}$ (14 °F)</p>
<p>Ø 8 mm</p>	<p>$R_1 \geq 40\text{ mm}$</p>	<p>$R_2 \geq 100\text{ mm}$</p>



$U_P = 5\text{ V} \pm 10\%$
(max. 550 mA)



A: 0.8 ... 1.2V_{SS}
B: 0.8 ... 1.2V_{SS}
R: 0.2 ... 0.85 V

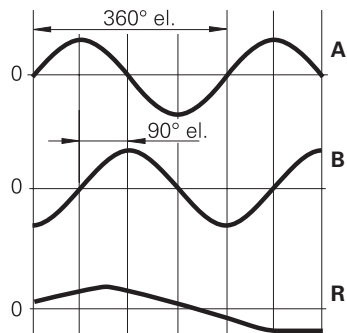

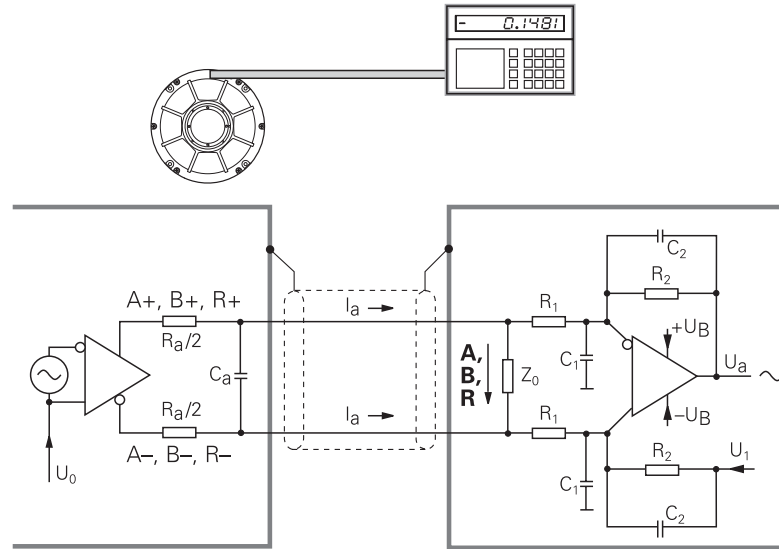

$R_a < 100 \Omega$
 $C_a < 50 \text{ pF}$
 $\Sigma I_a < 1 \text{ mA}$
 $U_0 = 2.5 \text{ V} \pm 0.5 \text{ V}$

$Z_0 = 120 \Omega$
 $U_1 \approx U_0$

Elektrischer Anschluß ohne Kappe · Electrical connection without cover · Raccordement électrique sans capot

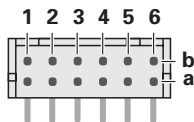
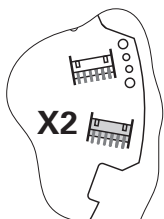

Die Sensorleitung ist intern mit der Versorgungsleitung verbunden.
 The sensor line is connected internally with the power supply.
 La ligne de palpeur est reliée de manière interne à la ligne d'alimentation.
 La linea del sensore è collegata internamente con la linea di alimentazione.
 La línea de sensor está unida internamente con la línea de alimentación.

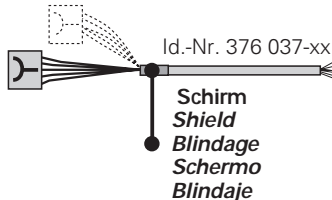

	10	9	8	7	6	5	3	4	1	2	
	6b	6a	5b	5a	4b	4a	2a	2b	1a	1b	3a, 3b
	A		B		R		5 V Up	5 V sensor	0 V U_N	0 V sensor	/
	+	-	+	-	+	-					
	braun/blau brown/blue brun/bleu marrone/azzurro marrón/azul	weiß/blau white/blue blanc/bleu bianco/azzurro blanco/azul	braun/rosa brown/pink brun/rose marrone/rosa marron/rosa	weiß/rosa white/pink blanc/rose bianco/rosa blanco/rosa	braun/grau brown/gray brun/gris marrone/grigio marron/gris	weiß/grau white/gray blanc/gris bianco/grigio blanco/gris	braun/grün brown/green brun/vert marrone/verde marron/verde	braun/gelb brown/yellow brun/jaune marrone/giallo marron/amarillo	weiß/grün white/green blanc/vert bianco/verde blanco/verde	weiß/gelb white/yellow blanc/jaune bianco/giallo blanco/amarillo	
	Abtaststelle A Scanning position A Position de balayage A Posizione di scansione A Posición de palpación A										

Collegamento elettrico senza coperchio · Conexión eléctrica sin cubierta

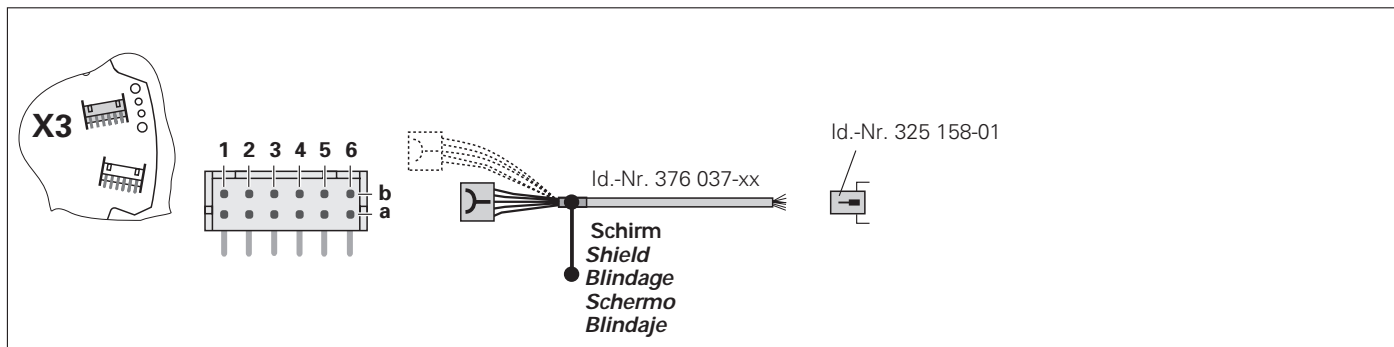

	14	13	12	11	18	17	16	15	22	21	20	19	23-26
	2b	2a	1b	1a	4b	4a	3b	3a	6b	6a	5b	5a	
	A		B		A		B		A		B		/
	+	-	+	-	+	-	+	-	+	-	+	-	
	grün green vert verde verde	gelb yellow jaune giallo amarillo	braun brown brun marrone marrón	weiß white blanc bianco blanco	rot red rouge rosso rojo	blau blue bleu azzurro azul	rosa pink rose rosa rosa	grau gray gris grigio gris	rot/blau red/blue rouge/bleu rosso/azzurro rojo/azul	grau/rosa gray/pink gris/rose grigio/rosa gris/rosa	violett violet violet viola violeta	schwarz black noir nero negro	
	Abtaststelle B Scanning position B Position de balayage B Posizione di scansione B Posición de palpación B				Abtaststelle C Scanning position C Position de balayage C Posizione di scansione C Posición de palpación C				Abtaststelle D Scanning position D Position de balayage D Posizione di scansione D Posición de palpación D				

Elektrischer Anschluß · *Electrical connection* · Raccordement électrique · *Collegamento elettrico* · Conexión eléctrica

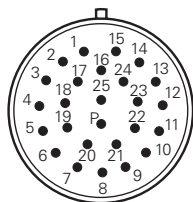

Shield
Shield
Blindage
Schermo
Blindaje



3	4	1	2	23-26	10	9	8	7	6	5
5V U _P	5V sensor	0V U _N	0V sensor	/	A		B		R	
					+	-	+	-	+	-
braun/grün <i>brown/green</i> brun/vert <i>marrone/verde</i> marron/verde	braun/gelb <i>brown/yellow</i> brun/jaune <i>marrone/giallo</i> marron/amarillo	weiß/grün <i>white/green</i> blanc/vert <i>bianco/verde</i> blanco/verde	weiß/gelb <i>white/yellow</i> blanc/jaune <i>bianco/giallo</i> blanco/amarillo	/	braun/blau <i>brown/blue</i> brun/bleu <i>marrone/azzurro</i> marrón/azul	weiß/blau <i>white/blue</i> blanc/bleu <i>bianco/azzurro</i> blanco/azul	braun/rosa <i>brown/pink</i> brun/rose <i>marrone/rosa</i> marron/rosa	weiß/rosa <i>white/pink</i> blanc/rose <i>bianco/rosa</i> blanco/rosa	braun/grau <i>brown/gray</i> brun/gris <i>marrone/grigio</i> marron/gris	weiß/grau <i>white/gray</i> blanc/gris <i>bianco/grigio</i> blanco/gris

Die Sensorleitung ist intern mit der Versorgungsleitung verbunden.

The sensor line is connected internally with the power supply.

La ligne de palpeur est reliée de manière interne à la ligne d'alimentation.

La linea del sensore è collegata internamente con la linea di alimentazione.

La línea de sensor está unida internamente con la línea de alimentación.

Abtaststelle **A**

Scanning position A

Position de balayage **A**

Posizione di scansione A

Posición de palpación **A**



14	13	12	11	18	17	16	15	22	21	20	19
A		B		A		B		A		B	
+	-	+	-	+	-	+	-	+	-	+	-
grün <i>green</i> vert verde verde	gelb <i>yellow</i> jaune giallo amarillo	braun <i>brown</i> brun marrone marrón	weiß <i>white</i> blanc bianco blanco	rot <i>red</i> rouge rosso rojo	blau <i>blue</i> bleu azzurro azul	rosa <i>pink</i> rose rosa rosa	grau <i>gray</i> gris grigio gris	rot/blau <i>red/blue</i> rouge/bleu rosso/azzurro rojo/azul	grau/rosa <i>gray/pink</i> gris/rose grigio/rosa gris/rosa	violett <i>violet</i> violet viola violeta	schwarz <i>black</i> noir nero negro
Abtaststelle B <i>Scanning position B</i> Position de balayage B <i>Posizione di scansione B</i> Posición de palpación B				Abtaststelle C <i>Scanning position C</i> Position de balayage C <i>Posizione di scansione C</i> Posición de palpación C				Abtaststelle D <i>Scanning position D</i> Position de balayage D <i>Posizione di scansione D</i> Posición de palpación D			

HEIDENHAIN

DR. JOHANNES HEIDENHAIN GmbH

Dr.-Johannes-Heidenhain-Straße 5

83301 Traunreut, Germany

☎ +49/86 69/31-0

FAX +49/86 69/50 61

E-Mail: info@heidenhain.de

Technical support FAX +49/86 69/31-10 00

Measuring systems ☎ +49/86 69/31-31 04

E-Mail: service.ms-support@heidenhain.de

TNC support ☎ +49/86 69/31-31 01

E-Mail: service.nc-support@heidenhain.de

NC programming ☎ +49/86 69/31-31 03

E-Mail: service.nc-pgm@heidenhain.de

PLC programming ☎ +49/86 69/31-31 02

E-Mail: service.plc@heidenhain.de

Lathe controls ☎ +49/7 11 95 28 03-0

E-Mail: service.hsf@heidenhain.de

www.heidenhain.de

