

Außenschirm auf Gehäuse
External shield on housing
 blindage externe sur boîtier
 schermo esterno sulla carcassa
 blindaje externo a carcasa

1) Innenschirm
Internal shield
 blindage interne
 schermo interno
 pantalla interna

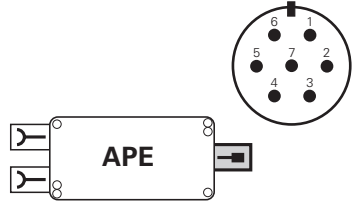

4	5	6	3	2	1	7
S/S	B/B	W/W	R	15 ... 30 V U _P	0V U _N	1)
EN 50 178						

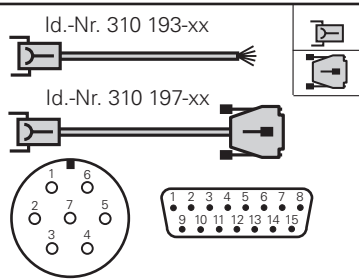

Id.-Nr. 310 193-xx	4	5	6	3	2	1	7
Id.-Nr. 310 197-xx	10	3	7	4	5	8	1
	S/S	B/B	W/W	R	15 ... 30 V U _P	0V U _N	1)
	grün green vert verde	grau gray gris grigio gris	blau blue bleu azzurro azul	gelb yellow jaune giallo amarillo	braun brown brun marrone marrón	weiß white blanc bianco blanco	weiß/braun white/brown blanc/brun bianco/marrone blanco/marrón
EN 50 178							

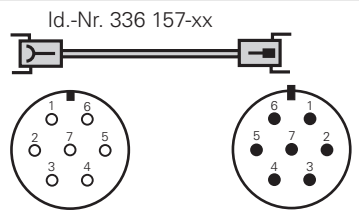

Id.-Nr. 336 157-xx	4	5	6	3	2	1	7
	S/S	/	W/W	/	15 ... 30 V U _P	0V U _N	1)
	grün green vert verde	grau gray gris grigio gris	blau blue bleu azzurro azul	gelb yellow jaune giallo amarillo	braun brown brun marrone marrón	weiß white blanc bianco blanco	
EN 50 178							

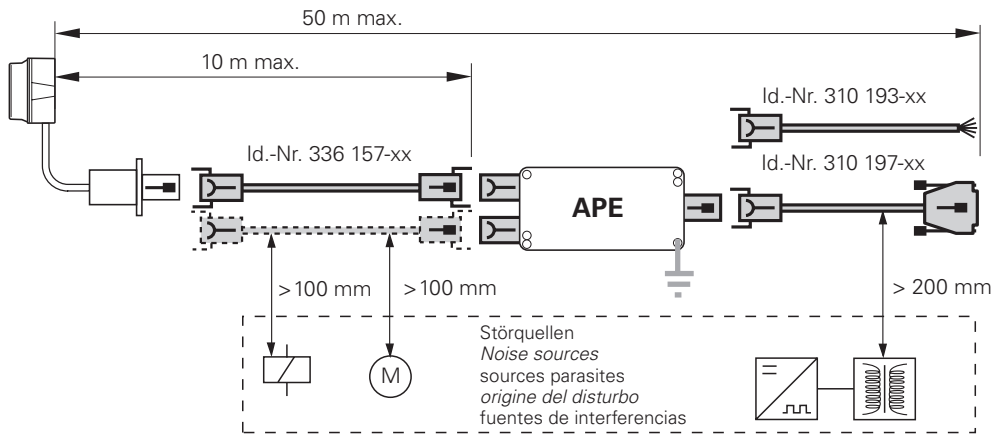

EA 652 APE 652

Montageanleitung Mounting Instructions Instructions de montage Istruzioni di montaggio Instrucciones de montaje

10/2001



DR. JOHANNES HEIDENHAIN GmbH
 Dr.-Johannes-Heidenhain-Straße 5
 83301 Traunreut, Germany
 ☎ + 49/86 69/31-0
 ☎ + 49/86 69/31-12 72
 ☎ TNC-Service + 49/86 69/31-14 46
 ☎ + 49/86 69/98 99
 e-mail: info@heidenhain.de
 e-mail: service@heidenhain.de
 www.heidenhain.de

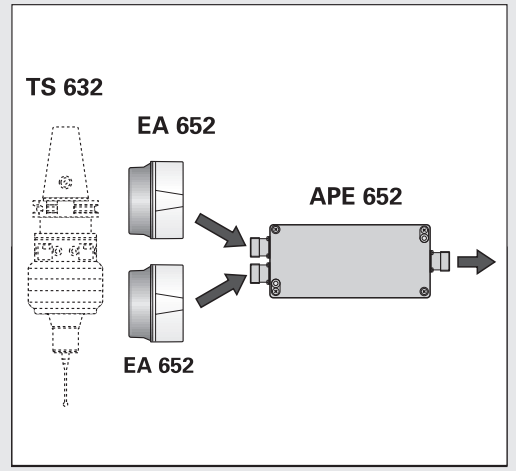
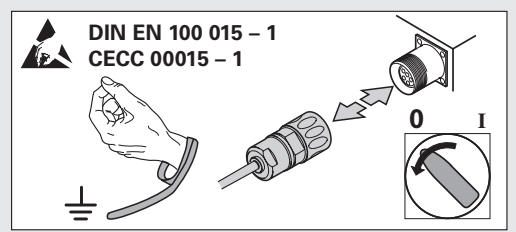

Elektrische Kennwerte · Electrical Data · Valeurs électriques · Dati elettrici · Datos eléctricos

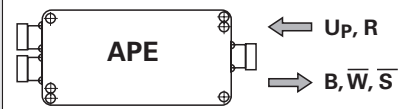

$U_P = 15\text{ V} \dots 29\text{ V}$
(max. 75 mA)

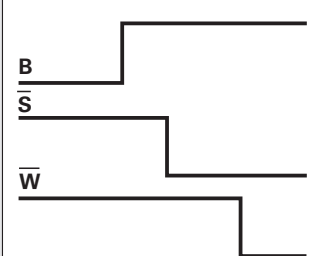

R = Startsignal
Start signal
Signal de départ
Segnale di partenza
Señal de inicio

R:
 $U_H = (10 \dots 30)\text{ V}$
 $U_L \leq 2\text{ V}$ ($I_H = U_H - 10\text{ V}$)
 $I_L \leq 100\ \mu\text{A}$ ($10\text{ k}\Omega$)
 $t \geq 100\ \mu\text{s}$

B = Bereitschaftssignal
Ready signal
Signal de réponse
Segnale di pronto
Señal de disposición

B, S, W:
 $U_H \geq [U_P - 2.2\text{ V}]$
($-I_H \leq 20\text{ mA}$)
 $U_L \leq 1.8\text{ V}$
($I_L \leq 100\text{ mA}$)

S = Schaltsignal
Trigger signal
Signal de commutation
Segnale di commutazione
Señal de conexión

W = Batteriewarnung (Batteriekapazität < 10%)
Battery warning (Battery capacity < 10%)
Témoin batterie (capacité batterie < 10%)
Allarme batteria (capacità batteria < 10%)
Aviso de batería (capacidad de la batería < 10%)

Signalfolge · Signal Sequence · Train de signaux · Sequenza di segnali · Tren de señales

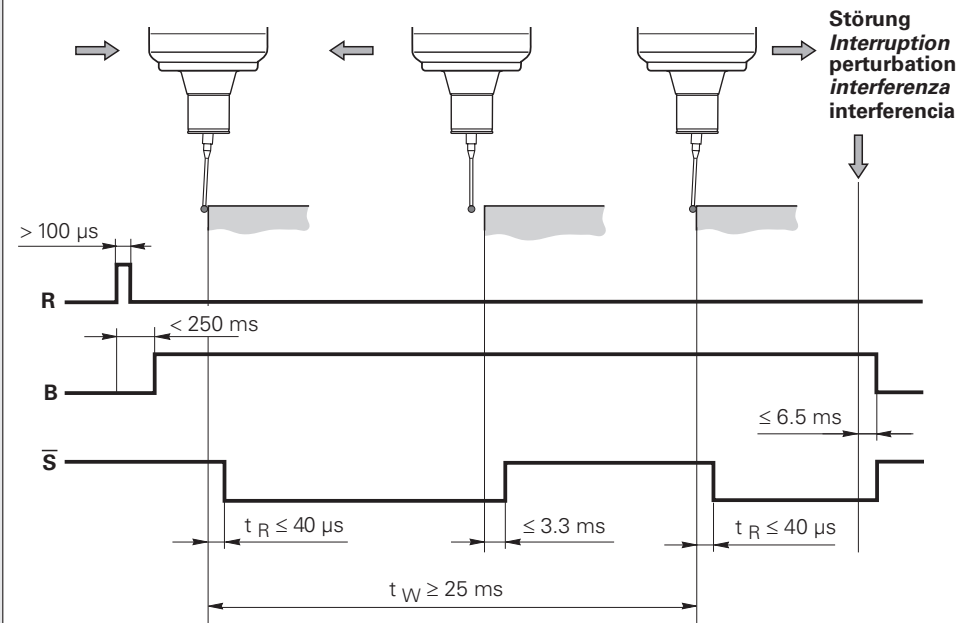

DIN EN 100 015 - 1
CECC 00015 - 1

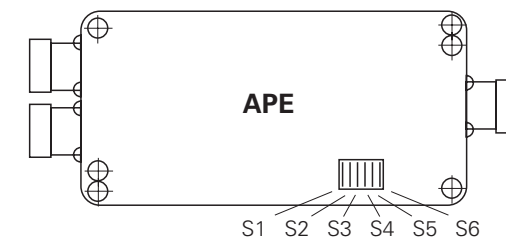
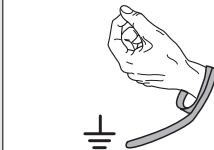

	Standard	Signal	Optional	Signal
S1		\bar{S}		S
S2		\bar{W}		W
S3		B		\bar{B}
S4		R		\bar{R}
S5		$\bar{B} = \bar{B} + \bar{W}$ $B = B$		$B = B + \bar{W}$ $\bar{B} = B + W$
S6		$\bar{S} = \bar{S}$ $S = S$		$\bar{S} = B + \bar{S}$ $S = B + S$

EA 652

Maße in mm
Dimensions in mm
cotes en mm
dimensioni in mm
dimensiones en mm

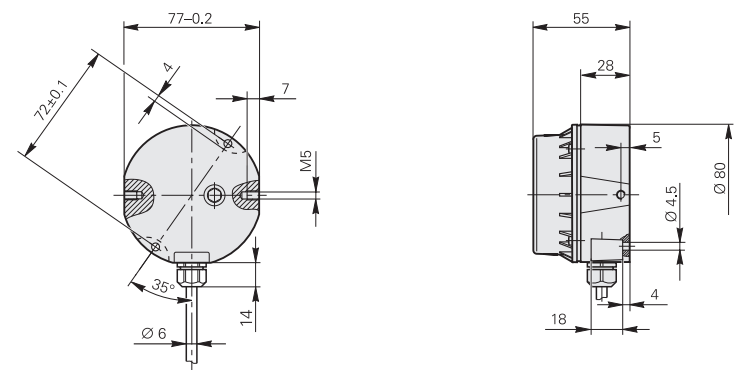

APE 652

