



HEIDENHAIN



User's Manual

ND 281 B

Measured Value Displays





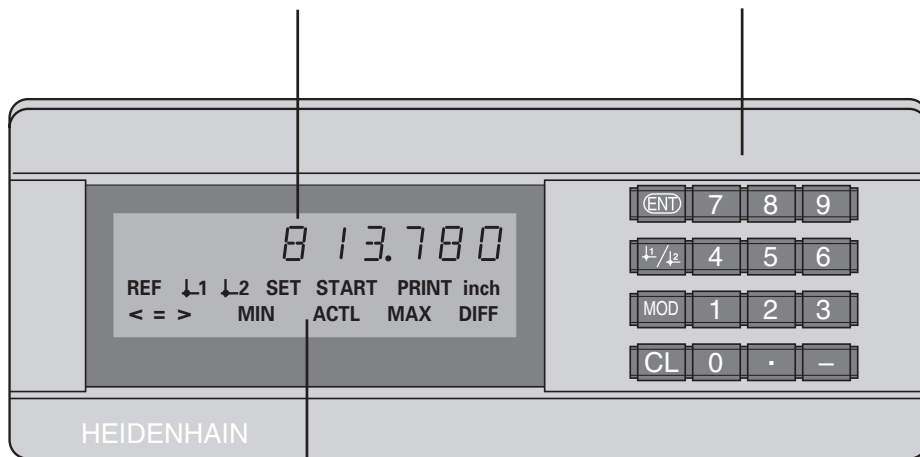

6/2000



Display of actual value and input
(9 decades with algebraic sign)

Numeric keypad with decimal point



Status display with indicators

Key	Function
	<ul style="list-style-type: none"> • Set datum • Transfer input value • Set display to value from P79 (P80!) • Leave parameter list
	<ul style="list-style-type: none"> • Select datum • Page backwards in parameter list
	<ul style="list-style-type: none"> • Select parameter after switch-on • Page forward in parameter list • Start series of measurements ¹⁾ • Switch display for measurement series ¹⁾ • Start measured value output "PRINT"
	<ul style="list-style-type: none"> • Delete entry • Set display to zero (P80!) • CL plus MOD: select parameter list • CL plus number: select parameter • Delete parameter input and show parameter number
	<ul style="list-style-type: none"> • Algebraic sign • Reduce parameter value
	<ul style="list-style-type: none"> • Decimal point • Increase parameter value

Indicator	Meaning
REF	<p>If the decimal point is also blinking: Display is waiting for reference mark traversing. If decimal point is not blinking: Reference mark has been traversed—display stores datum points in nonvolatile memory</p> <p>Blinking: display is waiting for ENT or CL to be depressed</p>
inch	Position values in inches
 1 /  2	Selected datum point
PRINT	<p>"Linear measurement" Blinking: Display is waiting for ENT to be pressed for data output</p> <p>"Angular measurement" Measured value output with MOD key</p>
SET	Blinking: Display is waiting for input values
< / = / >	<p>Sorting and tolerance checking: measured value smaller than lower limit / within the limits / greater than upper limit</p>
MIN / MAX /	<p>Series of measurements: Minimum / maximum / greatest difference (MAX–MIN) / current measured value</p>
DIFF / ACTL¹⁾	Blinking: Confirm selection or deselect function
START ¹⁾	<p>Series of measurements is running</p> <p>Blinking: Display is waiting for signal to start series of measurements</p>

¹⁾ Only in linear measurement mode.

Items supplied with ND 281 B

ND 281 B	Measured value display unit, benchtop model
Encoder input $11 \mu A_{PP}/1 V_{PP}$	Id. Nr. 344 996-xx
Power cord	3 m (9.9 ft)
User's Manual	ND 281B
Adhesive plug-in feet	For stacking ND 281B units



This manual is for the ND 281 B measured value display with the following software number or higher:

349 797-01

The software number is indicated on a label on the rear panel.

Contents

Working with the ND Display Units

Encoders	6
Reference Marks	7
Switch-On, Traversing the Reference Marks	8
Datum Setting	9
Finding Minimum and Maximum Values ¹⁾	10
Sorting and Tolerance Checking	13
Measured Value Output	14
Display Freeze	15
Error Messages	16

Installation and Specifications

Rear Panel, Accessories	17
Mounting	19
Power Connection	20
Linear/Angular Measuring Modes	21
Operating Parameters	22
List of Operating Parameters	24
Linear Encoders	28
Angle Encoders	33
Nonlinear Axis Error Compensation	34
RS-232-C/V.24 Interface (X31)	38
Switching Inputs and Outputs EXT (X41)	43
Locking the Keypad	48
Displaying the Software Version	49
Distance-to-Go Mode	50
Specifications	51
Dimensions	52

¹⁾ Only in linear measurement mode

Position Encoders

The ND 281 B display unit is designed for use with photo-electrical linear or angular encoders with sinusoidal signals: primarily for HEIDENHAIN **MT length gauges**.

When shipped by HEIDENHAIN, the display units are set to the linear measurement mode.

You can switch between the linear and angular modes by entering the code number **415263** (see "Linear/Angular Measurement Modes").

On the back of the display you will find two flange sockets for connecting the encoder: X1 for encoders with $11 \mu\text{A}_{\text{PP}}$ sinusoidal current signals and X2 for 1V_{PP} sinusoidal voltage signals.

Before shipping, HEIDENHAIN activates the encoder connection X1 for $11 \mu\text{A}_{\text{PP}}$ sinusoidal current signals. With parameter P02 you can activate the encoder input that matches your encoder (see "Operating Parameters").

Reference Marks

The MT length gauges have **one** reference mark. The scales of other photoelectric linear or angular encoders can contain one reference mark or many *distance-coded* reference marks.

If there is an interruption of power, the relationship between the position of the length gauge and the displayed position value is lost. The reference marks on the position encoders and the REF reference mark evaluation feature enable the display unit to quickly reestablish this relationship again when the power is restored.



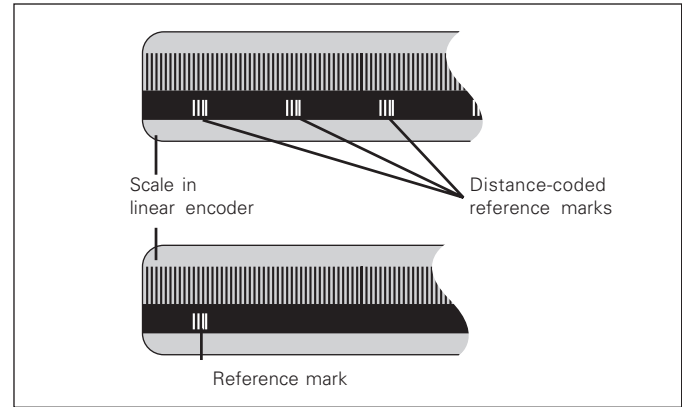

When a reference mark is crossed over, a signal is generated which identifies that position as a reference point. At the same time, the display unit restores the relationship between length gauge position and display values which you last defined by setting the datum.

To restore the datum on scales with **distance-coded** reference marks, you only need to traverse a maximum of 20 mm for linear encoders, and 10° or 20° for angle encoders, depending on the model.



Reference marks on linear encoders

Switch-On, Traversing the Reference Marks

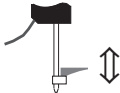
 	<p>Turn on the power. (Switch located on rear panel.)</p> <ul style="list-style-type: none"> • ND 281 B appears for two seconds. • ENT . . . CL ¹⁾ appears. • REF indicator is blinking.
 	<p>Switch-on the reference mark evaluation function.</p> <ul style="list-style-type: none"> • The position value that was last assigned to the reference mark position is displayed. • REF indicator lights up. • Decimal point is blinking.
	<p>Cross over the reference mark. Move the plunger until the display starts counting and the decimal point stops blinking. The display is now ready for operation.</p>

For automation purposes, crossing over the reference marks and the display ENT ... CL can be disabled with parameter P82.

REF Mode

Crossing over the reference marks automatically switches the display to REF mode: The last assignment of display values to length gauge positions is stored in nonvolatile memory.

1) Press the CL key if you choose **not** to traverse the reference marks. Note that, in this case, the relationship between length gauge position and display value will be lost if the power is interrupted or if the unit is switched off.

Datum Setting

The datum setting procedure assigns a display value to a known position. With the ND 200 series, you can set two separate datum points.

There are several ways to set the datum:

- Enter a numerical value, or
- Transfer a value from an operating parameter (see P79, P80), or
- By external signal

1/2

Select datum 1 or 2.

5

Enter numerical value (here, 5).
SET blinks.

5

ENT

Confirm the entered numerical value.

You can switch between datums 1 and 2 as desired. Datum 2 can be used, for example, for working with incremental dimensions.

When you switch back to datum 1, the display unit resumes display of the encoder's actual position.

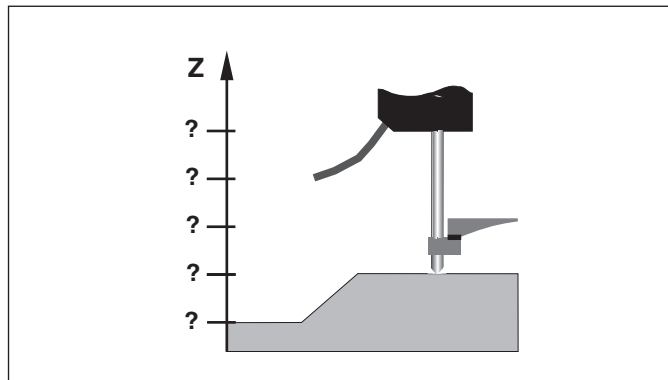

Without datum setting: unknown assignment of measured values to positions

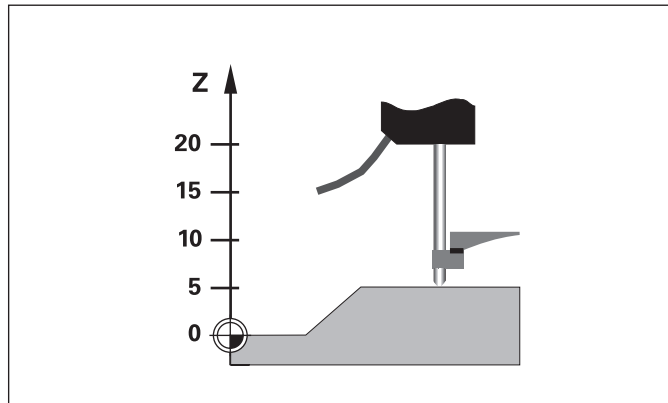

After datum setting: Assignment of measured values to positions

Finding Minimum and Maximum Values from a Series of Measurements ¹⁾

After a series of measurements has been started, the display transfers the first measured value to the memory for minimum and maximum values. Every 0.55 ms, the display compares the current measured value with the memory contents: A new value is stored if it is greater than the stored maximum value or smaller than the stored minimum value. At the same time, the display calculates and stores the difference DIFF between the current MIN and MAX values.

Display	Meaning
MIN	Minimum value from the series of measurements
MAX	Maximum value from the series of measurements
DIFF	Difference MAX – MIN
ACTL	Current measured value

Starting the measurement series and selecting the display

You can start the series of measurements either by pressing MOD and selecting the desired display—as described on the following pages—or by external signal over the **switching inputs at the D-sub connection EXT** (X41, see “Switching Inputs and Outputs”).

When a series of measurements is started, the internal MIN/MAX/DIFF memory is reset.

¹⁾ Only in the linear measurement mode.

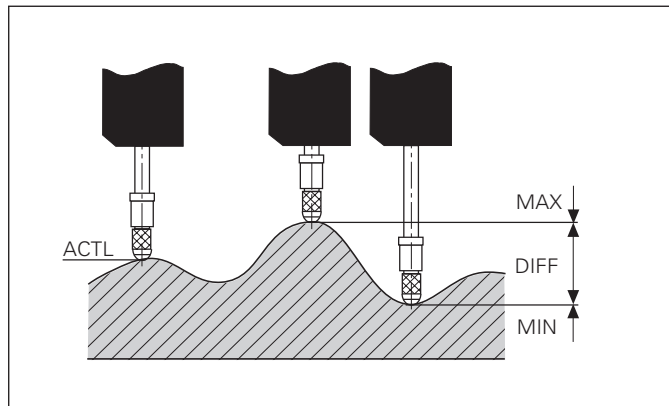

Series of measurements: The MIN, MAX and DIFF values of an uneven surface

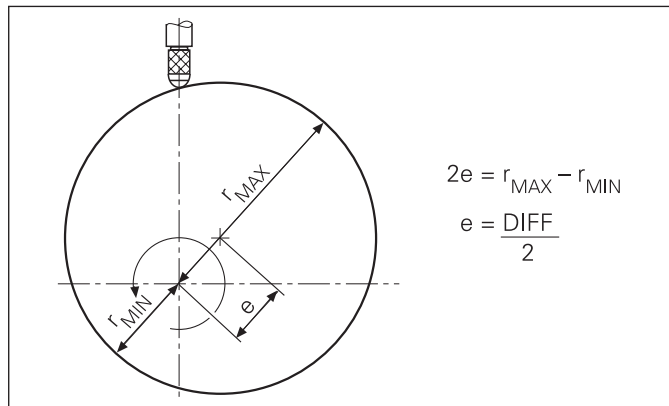

$$2e = r_{MAX} - r_{MIN}$$

$$e = \frac{DIFF}{2}$$

Example: Measurement series for determining eccentricity e

Starting a series of measurements

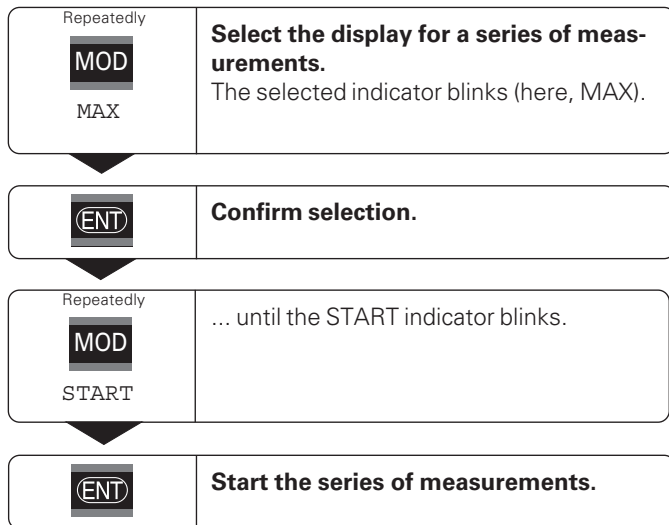

Indicator preselection

Press MOD to start the series of measurements and select the display with the indicators.

Operating parameter **P86** allows you to define which indicator is displayed first when MOD is pressed.

Switching between MIN, MAX, DIFF and ACTL displays



It is **not** possible to switch between the displays as described below if the switching input for external control of the series of measurements (pin 6 on D-sub connection EXT) is active.

As an alternative, you can select the display with operating parameter P21 (see "Operating Parameters").

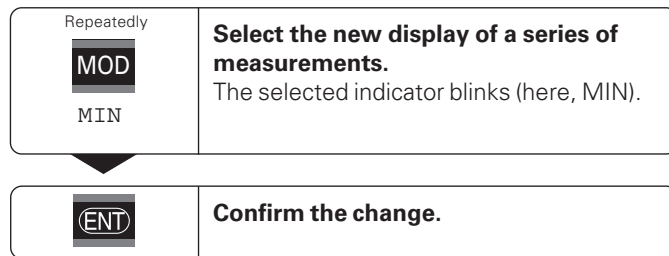

The display now shows the smallest value measured during the current series of measurements.

Starting a new series of measurements

Repeatedly  START	<p>Select the indicator START. The indicator START blinks.</p>
--	---

	<p>Start a new series of measurements.</p>
---	---

Ending a series of measurements

Repeatedly  START	<p>Select the active indicator (MIN, ACTL, MAX, DIFF). The indicator that lit up last blinks.</p>
--	--

	<p>End the series of measurements.</p>
---	---

or

Repeatedly  START	<p>Select the indicator START. The START indicator blinks.</p>
--	---

	<p>End the series of measurements.</p>
---	---

Sorting and Tolerance Checking

In the sorting and tolerance checking mode, the display unit compares the displayed value with the programmed upper and lower sorting limits. The sorting and tolerance checking mode is enabled and disabled with operating parameter **P17**.

Entering sorting limits

Sorting limits are entered in operating parameters **P18** and **P19** (see "Operating Parameters").

Sorting signals

The indicators and switching outputs at D-sub connection EXT (see section on X41) sort the display value into one of three classes.

Display	Meaning
=	Measured value is within sorting limits
<	Measured value is smaller than lower sorting limit
>	Measured value is greater than upper sorting limit

Operating parameters for sorting and tolerance checking	
P17 SORT	Sorting ON/OFF
P18 L.LIMIT	Lower sorting limit
P19 U.LIMIT	Upper sorting limit

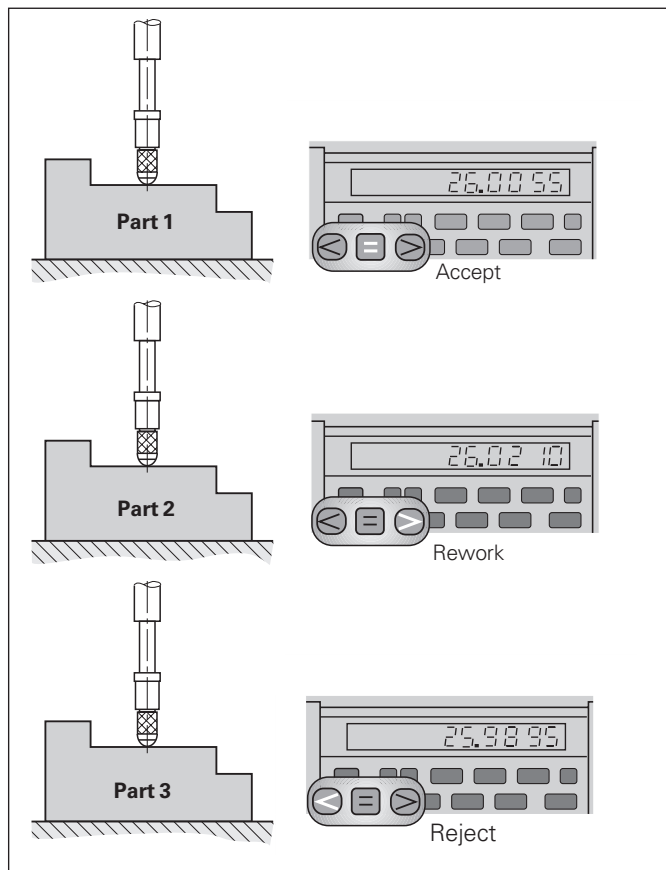

Example: Upper sorting limit = 26.02 mm
Lower sorting limit = 26.00 mm

Measured Value Output



For technical information on the RS-232-C/V.24 data interface (X31), information on the data format, etc., see the chapter "RS-232-C/V.24 Interface (X31)."

Measured values can be output over the RS-232-C/V.24 interface (X31), for example to a printer or PC.

There are several ways to start measured value output:

- In the **linear measurement** mode:
Press MOD repeatedly until the PRINT indicator blinks, then start measured value output with ENT.
- In the **angular measurement** mode:
Press the MOD key (this feature can be disabled with the operating parameter 86).
- or**
- Input the command STX (Ctrl B) over the RXD input of the RS-232-C/V.24 interface (X31);
- or**
- Input a signal for measured data output (Pulse or Contact) at the D-sub connection EXT (X41).

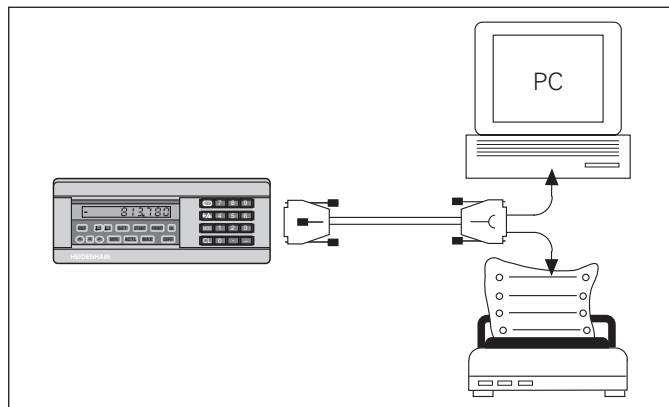

The RS-232-C/V.24 interface (X31) enables you to connect a printer or a PC to your display unit

Display Freeze

With the latch command, the display can be stopped for any period of time. The internal counter remains active. Parameter P23 selects the “display freeze” mode and offers three settings:

- **Concurrent display**, no display freeze—the display value is the current measured value.
- **Frozen display**—display value is frozen and is updated with each signal for measured value output.
- **Frozen/concurrent display**—display remains frozen as long as the latch signal is present; after the signal, the display resumes continuous display of the current measured values.

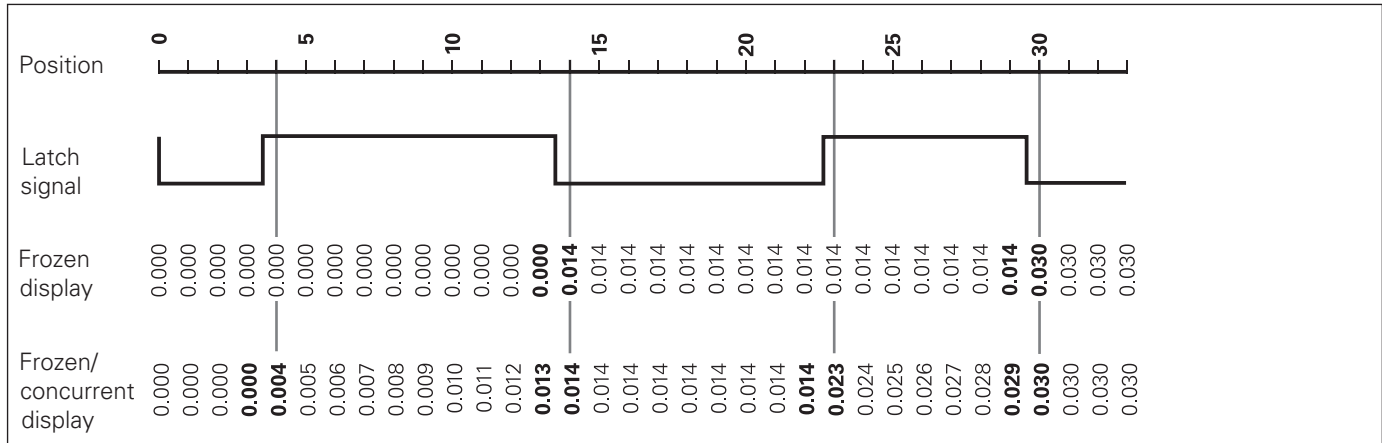

Error Messages

Display	Effect/Cause
RS232 FAST	Command for measured value output followed too quickly by another. ¹⁾
SIGNAL	Encoder signal is too weak. The scale may be contaminated. ¹⁾
DSR.MISSING	The connected device has not sent a DSR signal. ¹⁾
REF. ERR.	The spacing of the reference marks as defined in P43 is not the actual spacing. ¹⁾
FORMAT ERR.	Data format, baud rate, etc. do not match. ¹⁾
FREQUENCY	Input frequency too high for encoder input. Traversing speed may be too fast. ¹⁾
MEMORY ERR.	Checksum error: Check the datum, operating parameters and compensation values for nonlinear axis error compensation. If this error recurs, contact your service agency!

¹⁾ These errors are important for the attached device. The error signal (pin 19) at D-sub connection EXT is active.

Other Error Displays

If "OVERFLOW" appears, the measured value is too large or too small:

- ▶ Set a new datum.
- or**
- ▶ Traverse back.

If **all sorting signals light up**, the upper sorting limit is smaller than the lower limit:

- ▶ Change operating parameters P18 and/or P19.

To clear error messages:

Once you have removed the cause of the error:

- ▶ Clear the error message with the CL key.

Rear Panel



Ports X1, X2, X31 and X41 comply with the recommendations in EN 50 178 for separation from line power.

Encoder input X1

HEIDENHAIN flange socket	9-pin
Input signals	\sim 11 μ A _{PP}
Maximum encoder cable length	30 m (98.5 ft)
Maximum input frequency	100 kHz

Encoder input X2

HEIDENHAIN flange socket	12-pin
Input signals	1 V _{PP}
Maximum encoder cable length	60 m (197 ft)
Maximum input frequency	500 kHz

Rear Panel



Ports X1 X2, X31 and X41 comply with the recommendations in EN 50 178 for separation from line power.

RS-232-C/V.24 data interface (X31)

25-pin D-sub connection (female)

Switching inputs and outputs EXT (X41)

25-pin D-sub connection (male)

Accessories

Connecting elements

Connector (female)	25-pin for D-sub connection X41 Id. Nr. 249 154 ZY
Connector (male)	25-pin for D-sub connection X31 Id. Nr. 245 739 ZY
Data interface cable, complete	3 m (9.9 ft), 25-pin for D-sub connection X31, Id. Nr. 274 545-01

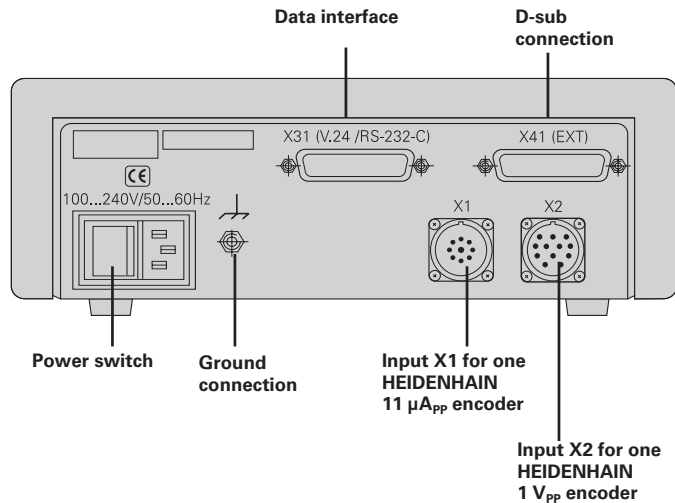

Mounting

You can fasten the ND 281 B from below by using M4 screws (see illustration at right).

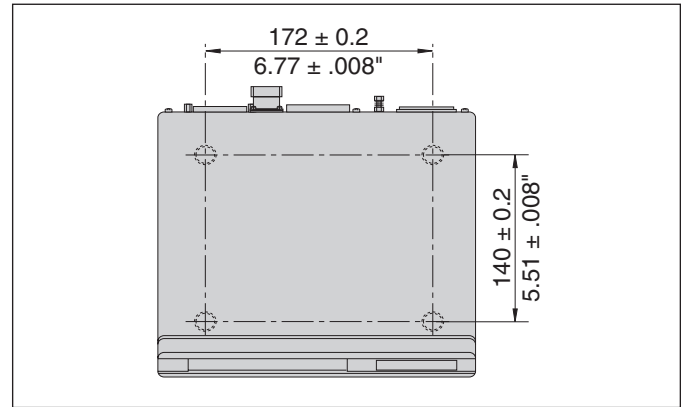

Hole positions for mounting the ND display unit

ND 281 B display units are stackable. Adhesive plug-in feet (supplied with your unit) prevent the stacked units from being moved out of place.

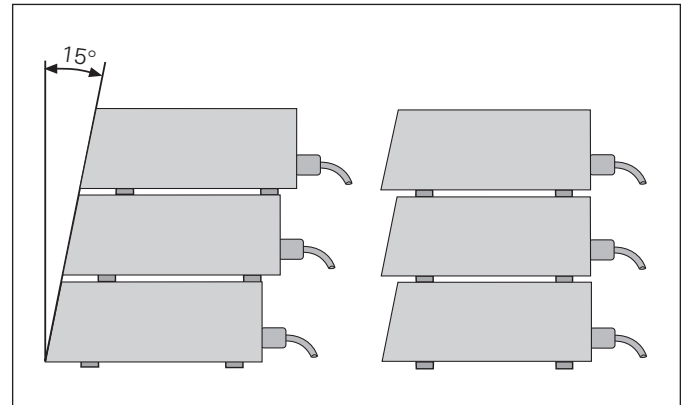

Alternatives of stacking the display units

Power Connection

The rear panel of the ND 281 B contains a connecting jack for a power cord with Euro connector (power cord supplied with the delivery).

Minimum cross section of the power cord: 0.75 mm²

Power supply: 100 Vac to 240 Vac (–15% to +10%)
50 Hz to 60 Hz (± 2 Hz)

A voltage selector is therefore not necessary.



Danger of electrical shock!

Unplug the power cord before opening the housing. Connect the grounding conductor. Do not interrupt the grounding conductor.



Danger to internal components!

Do not engage or disengage any connections while the unit is under power. Use only original replacement fuses.



To increase noise immunity, connect the ground terminal on the rear panel to the central ground point of the machine.
(Minimum cross-section: 6 mm²)

Linear/Angular Measuring Modes

You can select the linear measuring mode or angular measuring mode by entering the code number 415263:

- Select the user parameter P00 CODE (see "Operating Parameters").
- Enter the code number 415263.
- Confirm your entry with ENT.
- With the "." or "-" key, select the ND LENGTH or ND ANGLE mode, respectively.
- Confirm your selection with ENT.
- The display unit resets itself.
- For further procedure, see "Switch-on, Traversing the Reference Marks."

Operating Parameters

Operating parameters allow you to modify the operating characteristics of your ND display unit and define the evaluation of the encoder signals.

Operating parameters are designated by:

- the letter P,
- a two-digit parameter number, and
- an abbreviation.

Example: P01 INCH

The **factory settings of the operating parameters** are indicated in the parameter list (see “List of Operating Parameters”) in boldface type.

Parameters consist of “user parameters” and “protected operating parameters,” which can only be accessed by entering a code number.

User parameters

User parameters are operating parameters that can be changed **without** entering the code number:

P00 to P30, P50, P51, P79, P86, P98



The functions of the individual user parameters are detailed in the list of operating parameters (see “List of Operating Parameters”).

To access a user parameter ...



... after switching on the display:

While ENT ... CL is displayed: 	Display first user parameter.
---	-------------------------------

... during operation:

Together:  	Display first user parameter.
--	-------------------------------

To go directly to a user parameter:

Together:  	Press and hold CL while entering the first digit of the parameter number (here, 1).
--	---

	Enter the second digit of the parameter number (here, 9). The display shows the selected user parameter.
---	---

Code number for changing protected operating parameters

If you wish to change protected operating parameters, you must first enter the **code number 95 148**:

- Select the user parameter P00 CODE.
- Enter the code number 9 51 48.
- Confirm entry with ENT.

Parameter P30 appears on the display. By paging through the list of operating parameters you can display—and, if necessary, change—each protected operating parameter and, of course, each user parameter.



Once you have entered the code number, the protected operating parameters remain accessible until the display unit is switched off.

Functions for changing the operating parameters

Function	Key
Page forward in the list of operating parameters	
Page backward in the list of operating parameters	
Reduce parameter value	
Increase parameter value	
Correct entry and display parameter designations	
Confirm change or numerical entry, leave list of operating parameters	

A changed parameter is stored as soon as you

- leave the list of operating parameters
- or**
- page forward or backward after the change.

List of Operating Parameters

Parameter	Settings / Function
P00 CODE	Enter a code number : 9 51 48: To change the protected operating parameters 41 52 63: To select the linear or angular measurement mode 10 52 96: Nonlinear axis error compensation 24 65 84: To lock the keyboard 66 55 44: To show the software version 24 65 82: Distance-to-go display
P01	Units of measurement 1) Display in millimeters MM Display in inches INCH
P02 X1/X2	Select an encoder input Signals at X1 11 μAPP Signals at X2 1 VPP
P08 DISPL.	Display mode 2) Decimal Degrees DEC. DEGREE Deg., minutes, seconds DEG. MIN. SEC.
P09 ANGLE	Angle display 2) +/- 180° +/- 180 DEG. +/- ∞ ENDLESS 360° 360 DEG.

1) Only in linear measurement mode.

2) Only in angular measurement mode.

Parameter	Settings / Function
P11 SCL	Scaling factor 1) Scaling factor on SCALING ON Scaling factor off SCALNG. OFF
P12 SCL	Scaling factor 1) Enter a numerical value $0.100000 < P12 < 9.999999$ Default setting: 1.000000
P17 SORT	Sorting and tolerance checking Sorting and tol. checking ON SORT ON Sorting and tol. checking OFF SORT OFF
P18 L.LIMIT	Lower limit for sorting
P19 U.LIMIT	Upper limit for sorting
P21 SERIES	Display for series of measurements 1) OFF MIN MAX ACTL DIFF
P23 DISPL.	Display stop for measured value output Concurrent display , no display freeze; the display value is the current actual value DISPL. ACTL. Frozen display ; hold display until next measured value output DISPL. HOLD Frozen/concurrent display ; freeze display as long as Pulse/Contact for measured value output is present DISPL. STOP

Parameter	Settings / Function
P44 REF	<p>Reference mark evaluation Evaluate the reference mark REF. ON</p> <hr/> <p>Do not evaluate the reference mark REF. OFF</p>
P45 ALARM	<p>Encoder monitoring No monitoring ALARM OFF</p> <hr/> <p>Monitor the frequency FREQUENCY</p> <hr/> <p>Monitor contamination CONTAMINAT.</p> <hr/> <p>Contamination + frequency FRQ. + CONT.</p>
P50 RS232	<p>Baud rate 110 / 150 / 300 / 600 / 1200 / 2400 / 4800 / 9600 / 19 200 / 38 400 baud</p>
P51 RS232	<p>Additional blank lines during data output BK LINE 1 0 ≤ P51 ≤ 99 Default setting: 1</p>
P62 A1	Trigger limit 1
P63 A2	Trigger limit 2
P79 PRESET	<p>Value for datum point Enter numerical value for datum setting over switching input or with ENT key</p>

Parameter	Settings / Function
P80 ENT-CL	<p>Set display No set/Set with CL/ENT CL-ENT OFF</p> <hr/> <p>Zero reset with CL setting disabled with ENT CL ON</p> <hr/> <p>Zero reset with CL and set with ENT to value selected in P79 CL-ENT ON</p>
P82 DISPL.ON	<p>Message after switch-on ENT . . . CL message MESSAGE ON</p> <hr/> <p>No message MESSG. OFF</p>
P85 EXT.REF	<p>External REF REF over D-sub port EXT EXT.REF ON</p> <hr/> <p>No REF over D-sub port EXT EXT.REF OFF</p>
P86 MOD	<p>In the linear measurement mode First indicator after pressing MOD START PRINT MIN ACTL MAX DIFF</p> <hr/> <p>In the angular measurement mode PRINT via MOD disabled PRINT OFF</p> <hr/> <p>PRINT via MOD enabled PRINT ON</p>

Parameter	Settings / Function
P98 LANGUA.	Conversational language
German	LANGUAGE D
English	LANGUAGE GB
French	LANGUAGE F
Italian	LANGUAGE I
Dutch	LANGUAGE NL
Spanish	LANGUAGE E
Danish	LANGUAGE DK
Swedish	LANGUAGE S
Finnish	LANGUAGE FI
Czech	LANGUAGE CZ
Polish	LANGUAGE PL
Hungarian	LANGUAGE H
Portuguese	LANGUAGE P

Linear Encoders

The ND 281 B display unit is designed for use together with photoelectrical encoders with sinusoidal signals— $11 \mu A_{PP}$ or $1 V_{PP}$.

Display step with linear encoders

You can select a specific display step by adapting the following operating parameters:

- Signal period (P31)
- Counting mode (P33)
- Decimal places (P38)

Example

Linear encoder with a signal period of $10 \mu m$

Desired display step 0.000 5 mm

Signal period (P31) 10

Counting mode (P33) 5

Decimal places (P38) 4

The tables on the following pages will help you to select the appropriate parameter settings.

Recommended parameter settings for HEIDENHAIN linear encoders with 11 μA_{pp} signals

Model	Signal periods in μm P 31	Reference marks P 43	Millimeters			Inches		
			Display step in mm	Count mode P 33	Decimal places P 38	Display step in inches	Count mode P 33	Decimal places P 38
CT MT xx01	2	Single	0.0005	5	4	0.00002	2	5
LIP 401A/401R		Single	0.0002	2	4	0.00001	1	5
			0.0001	1	4	0.000005	5	6
		0.00005	5	5	0.000002	2	6	
		<i>Recommd. only for LIP 401</i>						
			0.00002	2	5	0.000001	1	6
			0.00001	1	5	0.0000005	5	7
			0.000005	5	6	0.0000002	2	7
LF 103/103C LF 401/401C LIF 101/101C LIP 501/501C	4	Single/5000	0.001	1	3	0.00005	5	5
LIP 101		Single	0.0005	5	4	0.00002	2	5
			0.0002	2	4	0.00001	1	5
			0.0001	1	4	0.000005	5	6
			0.00005	5	5	0.000002	2	6
		<i>Recommd. only for LIP 101</i>						
			0.00002	2	5	0.000001	1	6
			0.00001	1	5	0.0000005	5	7
MT xx	10	Single	0.0005	5	4	0.00002	2	5
			0.0002	2	4	0.00001	1	5
			0.0001	1	4	0.000005	5	6
LS 303/303C LS 603/603C	20	Single/1000	0.01	1	2	0.0005	5	4
			0.005	5	3	0.0002	2	4

Recommd. parameter settings for HEIDENHAIN linear encoders with 11 μA_{pp} signals (continued)

Model	Signal period in μm P31	Reference marks P 43	Millimeters			Inches		
			Display step in mm	Count mode P 33	Decimal places P 38	Display step in inches	Count mode P 33	Decimal places P 38
LS 106/106C LS 406/406C LS 706/706C	20	Single/1000	0.001	1	3	0.00005	5	5
ST 1201			0.0005	5	4	0.00002	2	5
LB 302/302C LIDA 10x/10xC	40	Single/2000	0.005	5	3	0.0002	2	4
			0.002	2	3	0.0001	1	4
			0.001	1	3	0.00005	5	5
			0.0005	5	4	0.00002	2	5
			<i>Recommd. only for LB 302</i>					
	0.0002	2	4	0.000001	1	5		
	0.0001	1	4	0.0000005	5	6		
LB 301/301C	100	Single/1000	0.005	5	3	0.0002	2	4
			0.002	2	3	0.0001	1	4
			0.001	1	3	0.00005	5	5
LIM 102	12800	Single	0.1	1	1	0.005	5	3
			0.05	5	2	0.002	2	3

Example

Your encoder:

MT 101

Desired display step:

0.0005 mm (0,5 μm)

Parameter settings:

P01 = mm, P43 = single, P31 = 10, P33 = 5, P38 = 4

Recommended parameter settings for HEIDENHAIN linear encoders with 1 V_{pp} signals

Model	Signal period in μm P31	Reference marks P 43	Millimeters			Inches		
			Display step in mm	Count mode	Decimal places	Display step in inches	Count mode	Decimal places
LIP 382	0.128	-	0.000002 0.000001	2 1	6 6	0.0000001 0.00000005	1 5	7 8
MT xx81 LIP 481A/481R	2	Single -/single	0.0005 0.0002 0.0001 0.00005	5 2 1 5	4 4 4 5	0.00002 0.00001 0.000005 0.000002	2 1 5 2	5 5 6 6
			<i>Recommd. only for LIP 401</i>					
			0.00002 0.00001 0.000005	2 1 5	5 5 6	0.000001 0.0000005 0.0000002	1 5 2	6 7 7
LF 183/183C LF 481/481C LIF 181/181C LIP 581/581C	4	Single/5000	0.001 0.0005 0.0002 0.0001	1 5 2 1	3 4 4 4	0.00005 0.00002 0.00001 0.000005	5 2 1 5	5 5 5 6
VM 182		-	0.00005	5	5	0.000002	2	6
			<i>Recommd. only for VM 182</i>					
			0.00002 0.00001	2 1	5 5	0.000001 0.0000005	1 5	6 7
LS 186/186C LS 486/486C	20	Single/1000	0.001 0.0005	1 5	3 4	0.00005 0.00002	5 2	5 5
ST 1281		-						

Recommended parameter settings for HEIDENHAIN linear encoders with 1 V_{pp} signals (continued)

Model	Signal period in μm P31	Reference marks P 43	Millimeters			Inch		
			Display step in mm	Count mode P 33	Decimal places P 38	Display step in inches	Count mode P 33	Decimal places P 38
			LB 382/382C LIDA 18x/18xC	40	Single/2000	0.005 0.002 0.001 0.0005	5 2 1 5	3 3 3 4
<i>Recommd. only for LB 382</i>			0.0002 0.0001	2 1	4 4	0.00001 0.000005	1 5	5 6
LB 381/381C	100	Single/1000	0.005 0.002 0.001	5 2 1	3 3 3	0.0002 0.0001 0.00005	2 1 5	4 4 5

Example

Your encoder:

LS 186 C

Desired display step:

0.001 mm (1 μm)

Parameter settings:

P01 = mm, P43 = 1 000, P31 = 20, P33 = 1, P38 = 3

Recommended parameter settings for HEIDENHAIN angle encoders with $11 \mu\text{A}_{\text{pp}} / 1 \text{V}_{\text{pp}}$ signals

Model	Signal periods per revolution P36	Reference marks	P43	Display step	Count mode	Decimal places
					P37	P38
ROD 450 / ROD 456 / ROD 486 / ROD 1080	3600	One	Single	0.01° 0.005° 0.001°	1 5 1	 3 3
ROD 250 C / ROD 280 C RON 255 C / RON 285 C	9000	Dist.- coded	500	0.005° 0.001°	5 1	3 3
ROD 250 C / ROD 280 C ROD 255 C / RON 285 C ROD 700 C / ROD 780 C RON 705 C / RON 785 C RON 706 C / RON 786 C	18 000	Dist.- coded	1000	0.001° 0.0005° 0.0001°	1 5 1	3 4 4
RON 905 /	36 000	One	Single	0.0001°	1	4
ROD 800 C / ROD 880 C ROD 806 C / ROD 886 C	36 000	Dist.- coded	1000	0.0001°	1	4

Example:

Set parameters for any encoder

Angle encoder, e.g. with line count $s = 18\,000$ (P36)Desired display step, e.g. $a = 0.001^\circ$ **Counting mode** P37 = 1 (display counts 1, 2, 3, ...)**Decimal places** of a : P38 = 3**Convert decimal degrees into degrees, minutes, seconds**1 degree (1°) = 60 minutes ($60'$); 1 minute ($1'$) = 60 seconds ($60''$)1 second ($1''$) $\approx 0.000278^\circ$

Nonlinear Axis Error Compensation



If you want to use the nonlinear axis error compensation feature, you must:

- Activate the feature with operating parameter 40 (see “Operating Parameters”),
- Traverse the reference marks after switching on the display unit,
- enter a compensation value table

Your machine may have a nonlinear axis error due to factors such as axis sag or leadscrew errors. Such deviations are usually measured with a comparator measuring system (such as the HEIDENHAIN VM 101).

In the **linear measurement** mode:

You can make a compensation value table with 64 compensation values.

In the **angular measurement** mode:

You can make a compensation value table with 72 compensation points (point spacing: 5 degrees).

You select the compensation table through P00 CODE and by entering the code number 10 52 96 (see Operating Parameters).

Ascertaining the compensation values

To ascertain the compensation values (e.g. with a VM 101) you must select the compensation table and then press the “-” key to select the REF display.

The letter “R” at the left of the display indicates that the displayed position value is given with respect to the reference mark. If “R” blinks, you must traverse the reference mark.

Entries in the compensation value table

- Datum ¹⁾:
Here you enter the point at which the compensation is to begin. This point indicates the absolute distance to the reference point.



Do not change the datum after measuring the axis error and before entering the axis error into the compensation table.



- Spacing of the compensation points ¹⁾:
The spacing of the compensation points is expressed as:
$$\text{Spacing} = 2^x [\mu\text{m}].$$
Enter the value of the exponent x in into the compensation value table.
Minimum input value: 6 (= 0.064 mm)
Maximum input value: 20 (= 1048.576 mm)
Example: 900 mm traverse with 15 compensation points
==> 60.000 mm spacing between points.
Nearest power of two: $2^{16} = 65.536$ mm (see “Table for determining the point spacing”)
Input value in the table: 16
- Compensation value:
You enter the measured compensation value (in millimeters) for the displayed compensation point. Compensation point 0 always has the value 0 and cannot be changed.

¹⁾ Only in the linear measurement mode







Table for determining the point spacing



Exponent	Point spacing	
	in mm	in inches
6	0.064	0.0023"
7	0.128	0.0050"
8	0.256	0.0100"
9	0.512	0.0200"
10	1.024	0.0403"
11	2.048	0.0806"
12	4.016	0.1581"
13	8.192	0.3225"
14	16.384	0.6450"
15	32.768	1.290"
16	65.536	2.580"
17	131.072	5.160"
18	262.144	10.32"
19	524.288	20.64"
20	1048.576	41.25"



Selecting the compensation table, entering an axis correction





 together with 	Select the operating parameters.
---	----------------------------------





	Select P00 CODE.
---	------------------

P00 CODE	
   	Enter the code number 10 52 96, confirm with ENT.
  	

DATUM (shown for approx. two seconds) ¹⁾	
  	Enter the active datum for the error on the axis to be confirmed, e.g. 27 mm. Press MOD to select the next input box.

SPACING ¹⁾	
 	Enter the spacing of the compensation points on the axis to be corrected, for example 2 ¹⁰ μm (equals 1.024 mm). Press MOD four times to select COMP. NR. 01. (You cannot enter values in the POS. NR. 00, COMP. NR. 00 and POS. NR. 01 boxes.)
4 x 	

COMP. NR. 01	
   	Enter the associated compensation value, e.g. 0.01 mm. Press MOD twice to select COMP. NR. 02. (You cannot enter any values in the POS. NR. 02 box).
2 x 	

COMP. NR. 02	
   	Enter all further compensation points. If you want so select a compensation point directly, press CL and simultaneously enter the desired compensation point number.
2 x 	

	Conclude entry.
---	-----------------

¹⁾ Only in the linear measurement mode

Deleting a compensation value table

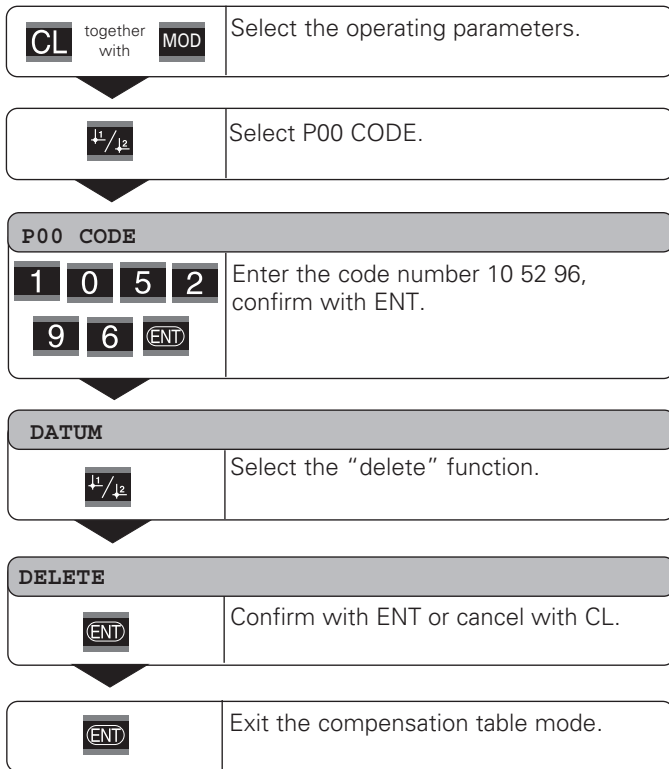

RS-232-C/V.24 Data Interface (X31)

The RS-232-C/V.24 interface (X31) of your display unit enables you to output measured data in ASCII format, for example to a printer or PC.

Connecting cable

You can use a connecting cable with full wiring (figure at upper right) or simplified wiring (below right). A cable with full wiring is available from HEIDENHAIN (Id. Nr. 274 545-...). On this type of cable, pin 6 and pin 8 are additionally connected over a jumper.

Maximum cable length: 20 m (66 ft)

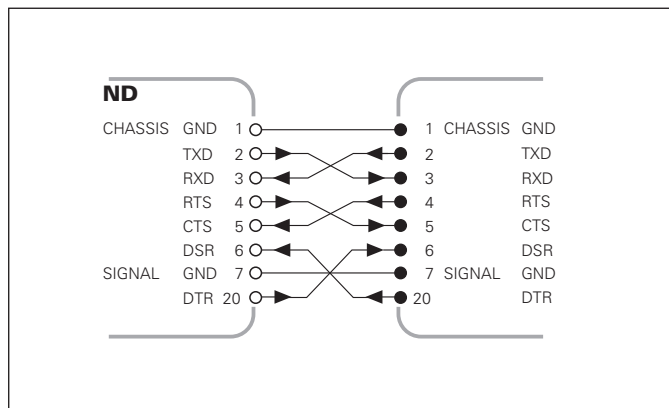

Full wiring

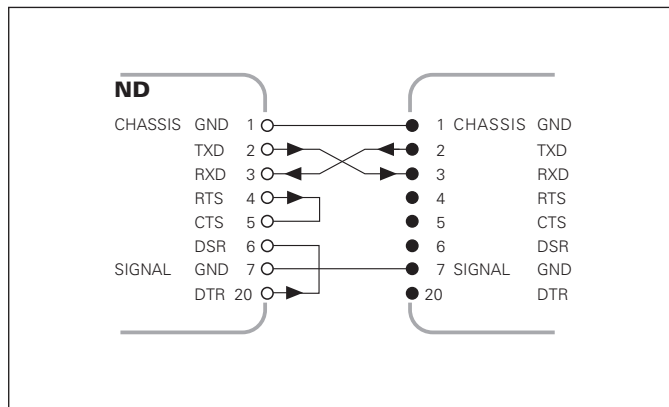

Simplified wiring

Pin layout RS-232-C/V.24 (X31)

Pin	Signal	Assignment
1	CHASSIS GND	Chassis ground
2	TXD	Transmitted data
3	RXD	Received data
4	RTS	Request to send
5	CTS	Clear to send
6	DSR	Data set ready
7	SIGN. GND	Signal ground
8 to 19	–	<i>Not assigned</i>
20	DTR	Data terminal ready
21 to 25	–	<i>Not assigned</i>

Levels for TXD and RXD

Logic level	Voltage level
Active	– 3 V to – 15 V
Not active	+ 3 V to +15 V

Levels for RTS, CTS, DSR and DTR

Logic level	Voltage level
Active	+ 3 V to + 15 V
Not active	– 3 V to – 15 V

Data format and control characters

Data format	1 start bit 7 data bits Even parity bit 2 stop bits
Control characters	Call measured value: STX (Ctrl B) Interrupt DC3 (Ctrl S) Continue DC1 (Ctrl Q) Interrogate error message: ENQ (Ctrl E)

Example: Data sequence during measured value output

Measured value = – 5.23 mm

The measured value is within the sorting limits (=) and is the current value (A) of a series of measurements.

Measured value output

–	5	.	2	3			=	A	<	C	R	>	<	L	F	>
---	---	---	---	---	--	--	---	---	---	---	---	---	---	---	---	---

- ① Algebraic sign
 ② Numerical value with decimal point (10 characters on the whole, leading zeros are output as blank spaces.) (Angle measurement "min, sec" up to 3 dec. spaces.)
 ③ Blank space
 ④ Unit: Blank space = mm; " = inch; ? = fault
 ⑤ Sorting status (<, >, =; ? if P18 > P19)
or blank space
 ⑥ Series of measurements (S = MIN; A = ACTL; G = MAX; D = DIFF)
or blank space
 ⑦ CR (carriage return)
 ⑧ LF (line feed)

Operating parameters for measured value output

Parameter	Function
P50 RS232	Baud rate
P51 RS232	Number of additional blank lines for measured value output

Display freeze during measured value output

In operating parameter P23, you can specify how the measured value output signal will affect the display unit.

Display freeze during measured value output	P23
Concurrent display , no display freeze: The display value is the current measured value	DISPL. ACTL.
Frozen display : Display is stopped (frozen) and updated by every measured value output signal	DISPL. HOLD
Frozen/concurrent display : Display is frozen as long as a measured value output signal is present	DISPL. STOP

Measured value output via PRINT function

In the **linear measurement** mode
Press MOD repeatedly until the indicator PRINT blinks.
Start the measured value output with ENT.
In the **angular measurement** mode
Press MOD (this feature can be disabled with operating parameter 86).

Duration of measured value transfer

$$t_D = \frac{187 + (11 \cdot \text{number of blank lines})}{\text{baud rate}} \text{ [s]}$$

Indicator preselection (linear measurement mode)

Operating parameter **P86** allows you to define which indicator is displayed first when MOD is pressed.

Measured value output after signal through the “Contact” or “Pulse” inputs

To start measured value output through the EXT interface (X41) you can either:

- Close the “Contact” input (pin 23 on X41) against 0 V, for example with a simple switch (make contact);
or
- Close the “Pulse” input (pin 22 on X41) against 0 V, for example by triggering the input with a TTL logic device (such as SN74LSxx).

Characteristic times for measured value output

Process	Time
Minimum duration of “Contact” signal	$t_e \geq 7 \text{ ms}$
Minimum duration of “Pulse” signal	$t_e \geq 1.5 \mu\text{s}$
Storage delay after “Contact”	$t_1 \leq 5 \text{ ms}$
Storage delay after “Pulse”	$t_1 \leq 1 \mu\text{s}$
Measured value output after	$t_2 \leq 57 \text{ ms}$
Regeneration time	$t_3 \geq 0$

Duration of measured value transfer

$$t_D = \frac{187 + (11 \cdot \text{number of blank lines})}{\text{baud rate}} \text{ [s]}$$

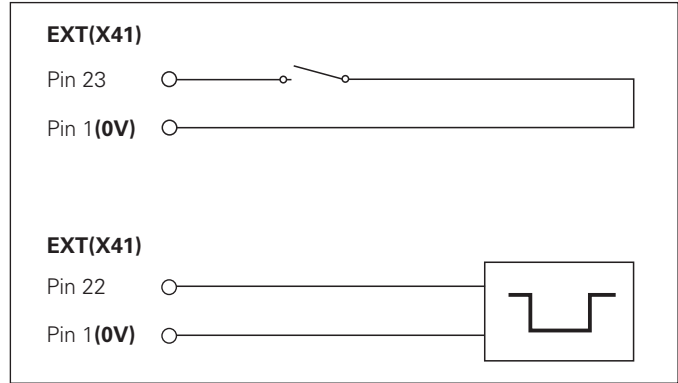

Triggering the “Contact” and “Pulse” inputs at D-sub connection EXT (X41)

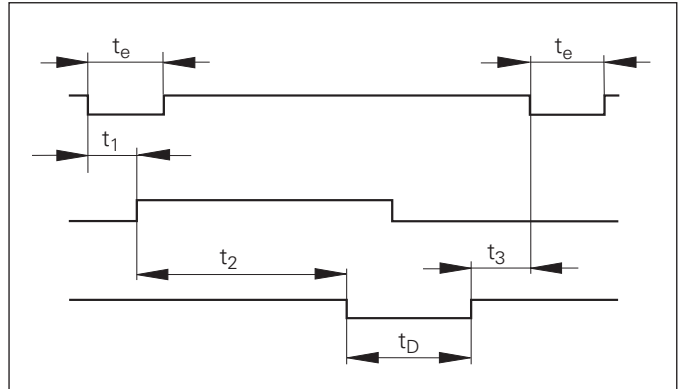

Signal transit times for measured value output after “Pulse” or “Contact”

Measured value output after "STX" signal (Ctrl B)

If the display unit receives the control character STX (Ctrl B) over the RS-232-C/V.24 interface (X31), it outputs the current measured value over the interface.

- Transfer the control character Ctrl B over the RXD line of the RS-232-C/V.24 interface (X31).

Characteristic times for measured value output

Process	Time
Storage delay	$t_1 \leq 1 \text{ ms}$
Measured value output after	$t_2 \leq 50 \text{ ms}$
Regeneration time	$t_3 \geq 0$



These times are prolonged if functions are active (for example, series of measurements with DIFF value display).

Duration of measured value transfer

$$t_D = \frac{187 + (11 \cdot \text{number of blank lines})}{\text{baud rate}} \text{ [s]}$$

```

10 L%=18
20 CLS
30 PRINT "V.24/RS-232-C"
40 OPEN "COM1:9600,E,7" AS#1
50 PRINT #1, CHR$(2);
60 IF INKEY$<>" THEN 130
70 C%=LOC(1)
80 IF C%<L% THEN 60
90 X$=INPUT$(L%,#1)
100 LOCATE 9,1
110 PRINT X$;
120 GOTO 50
130 END
    
```

BASIC program for measured value output with "Ctrl B"

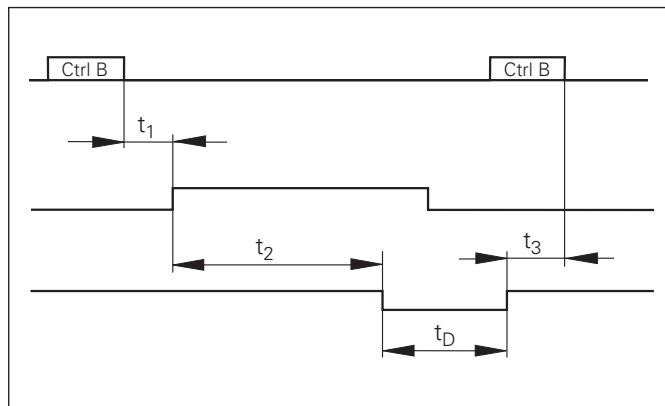

Propagation times for measured value output after "Ctrl B"

Switching Inputs and Outputs EXT (X41)



Danger to internal components!

Voltage sources for external circuitry must conform to the recommendations in EN 50 178 for low-voltage electrical separation. Connect inductive loads only with a quenching diode parallel to the inductance.



Only use shielded cable!

Connect the shield to the connector housing.

Outputs at D-sub connection EXT (X41)

Pin	Function
14	Display value is zero
15	Measured value \geq trigger limit A1 (P62)
16	Measured value \geq trigger limit A2 (P63)
17	Measured value $<$ lower sorting limit (P18)
18	Measured value $>$ upper sorting limit (P19)
19	Error (see "Error Messages")

¹⁾ Only in the linear measurement mode

Inputs at D-sub connection EXT (X41)

Pin	Function
1, 10	0 V
2	Reset display to zero, clear error message
3	Set display to the value selected in P79
4	Ignore reference mark signals
5	Start series of measurements ¹⁾
6	Externally select display value for series of measurements ¹⁾
7	Display MIN value of series of measurements ¹⁾
8	Display MAX value of series of measurements ¹⁾
9	Display difference MAX – MIN ¹⁾
22	Pulse: Output measured value
23	Contact: Output measured value
25	Enable or disable REF mode (current REF status is changed)
12, 13, 24	<i>Do not assign</i>
11, 20, 21	<i>Vacant</i>

Special case: Display current measured value ACTL

If you wish to display the current measured value ACTL of a series of measurements, note for inputs **7, 8 and 9**: Either none or more than one of these inputs must be active.

Inputs

Input signals

Internal pull-up resistor 1 k Ω , active with low level

Trigger by making contact against 0 V **or**
by low level signal over TTL logic device

Delay for set/zero reset: $t_d \leq 2$ ms

Minimum pulse duration for all signals: $t_{min} \geq 30$ ms

Signal level of inputs

Status	Level
High	$+ 3.9 \text{ V} \leq U \leq + 15 \text{ V}$
Low	$- 0.5 \text{ V} \leq U \leq + 0.9 \text{ V}; I \leq 6 \text{ mA}$

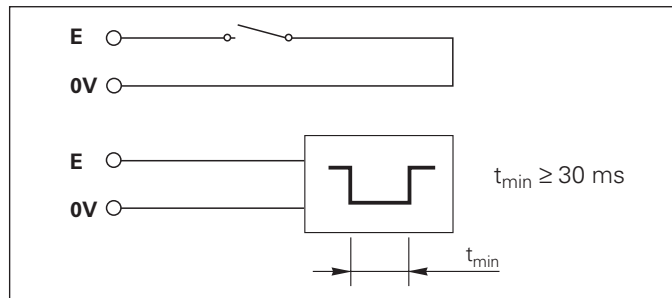

Outputs

Output signals

Open collector outputs, active with low level

Delay until signal output: $t_d \leq 30$ ms

Signal duration of zero signal, trigger limit A1, A2: $t_0 \geq 180$ ms

Signal level of outputs

Status	Level
High	$U \leq + 32 \text{ V}; I \leq 10 \mu\text{A}$
Low	$U \leq + 0.4 \text{ V}; I \leq 100 \text{ mA}$

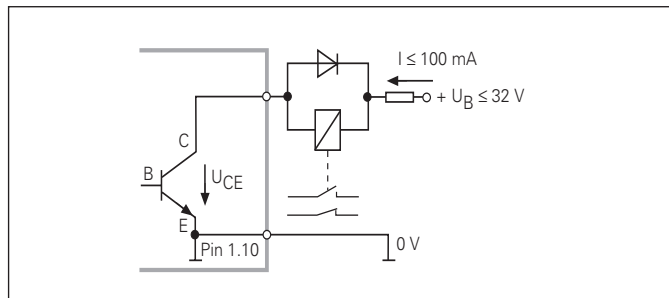

Setting and zero resetting the display

With an external signal, you can set the display to the value selected in parameter P79 (pin 3) or reset each axis to zero (pin 2).

Enabling and disabling REF mode

Operating parameter P85 allows you to activate the input (pin 25) which will be used for setting the display externally to REF mode when the unit is switched on or when the power is restored after an interruption. The next signal deactivates REF mode again (switchover function).

Ignoring reference mark signals

If this input (pin 4) is active, the display will ignore all reference mark signals. A typical application of this function is for measuring lengths with a rotary encoder and spindle; in this case, a cam switch releases the reference mark signal at a preset position.

Externally selecting MIN/MAX ¹⁾

Starting a series of measurements

Switching the display between MIN/MAX/DIFF/ACTL

You can activate the operating mode for finding minimum and maximum values from a series of measurements with an external signal (pin 6, low-level signal must be present continuously). The setting selected with MOD or operating parameter P21 is disabled. You can switch to MIN/MAX/DIFF/ACTL display (pins 7, 8, 9, low-level signal must be present continuously) and START (pin 5, Pulse) a new series of measurements only by external signal over the switching inputs.

¹⁾ Only in linear measurement mode.

Switching signals

As soon as the trigger points defined in parameters are reached, the corresponding outputs (pins 15, 16) are activated. You can set up to two trigger points. The switching point "zero" has a separate output (see "Zero crossover").

Signals for sorting and tolerance checking

If the sorting limits defined in parameters are exceeded, the corresponding outputs (pins 17, 18) are activated.

Signals	Operating parameters	Pin
Switching signals	P62, switching limit 1	15
	P63, switching limit 2	16
Sorting signals	P18, lower sorting limit	17
	P19, upper sorting limit	18

Zero crossover

The display value "zero" activates the corresponding output (pin 14). Minimum signal duration is 180 ms.

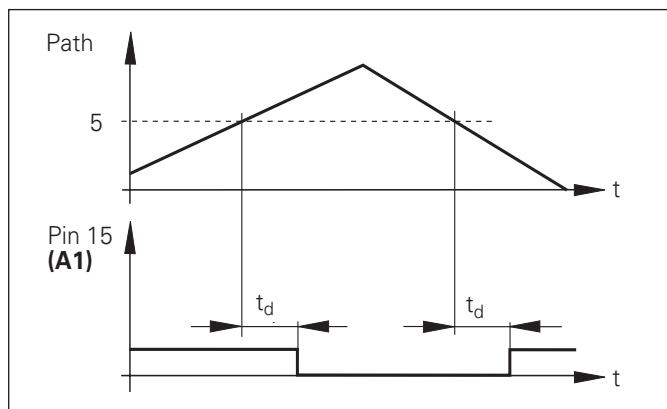
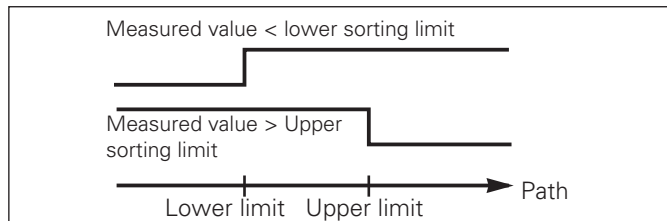
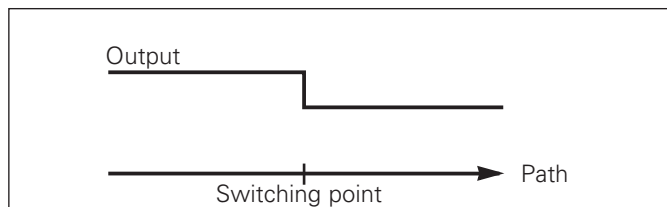

Time curve of signal at pin 15 for trigger limit (A1) = 5 mm , $t_d \leq 30$ ms

Switching signal for errors

The display unit permanently monitors functions such as measuring signal, input frequency, and data output, and displays an error message if it detects an error.

If errors occur that seriously influence measurement or data output, the display unit activates a switching output. This feature allows monitoring of automated processes.

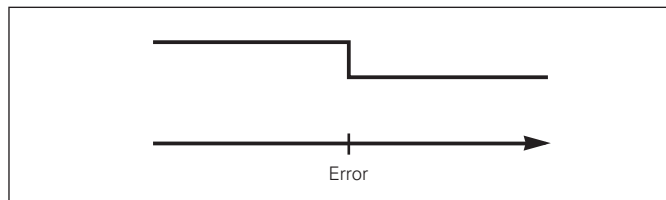

Locking the Keypad

You can disable or re-enable the keypad by entering the code number 24 65 84:

- Select the user parameter P00 CODE (see “Operating Parameters”).
- Enter the code number 24 65 84.
- Confirm the entry with ENT.
- With the “•” or “-” key, select KEYS ON or KEYS OFF.
- Confirm your selection with ENT.

If the keypad is locked, you can only select the datum or select P00 CODE over the MOD key.

Displaying the Software Version

To display the software version of the display unit, enter the code number 66 55 44:

- Select the user parameter P00 CODE.
- Enter the code number 66 55 44.
- Confirm your entry with ENT.
- The display unit shows the software number.
- With the “-” key you can switch the display to the date of issue.
- To exit the software version display mode, press ENT.

Distance-to-Go Display Mode ¹⁾

Normally, the display shows the actual position of the encoder. However, it is often more helpful to display the remaining distance to an entered nominal position—especially when you are using the display unit for machine tools and automation purposes. You can then position simply by traversing to display value zero.

You can access the distance-to-go display by entering the **code number 246 582**.

Display	Meaning
DELTA ON	Distance-to-go display active
DELTA OFF	Distance-to-go display not active

“Traversing to zero” with distance-to-go display

- Select datum point 2.
- Enter the nominal position.
- Move the axis until the display value is zero.

Function of switching outputs A1 and A2

In the distance-to-go mode, switching outputs A1 (pin 15) and A2 (pin 16) have a different function: they are symmetrical to the display value zero. For example, if a switching point of 10 mm is entered in P62, output A1 switches at both +10 mm and -10 mm. The figure below shows output signal A1 when approaching zero from the negative direction.

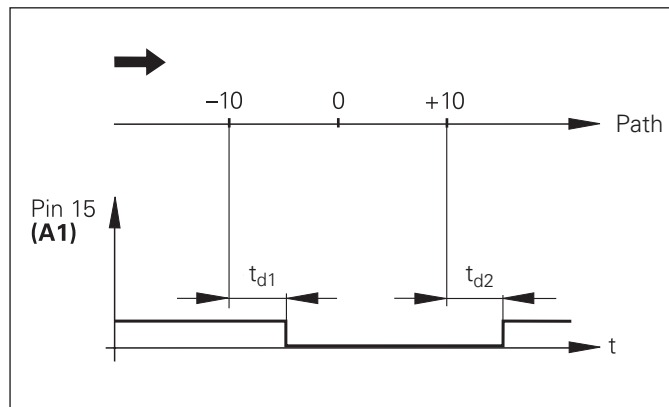

Time curve of a signal for switching limit (A1) = 10 mm,
 $t_{d1} \leq 30$ ms, $t_{d2} \leq 180$ ms

¹⁾ Only in linear measurement mode

Specifications

Housing	ND 281 B Benchtop design, cast-metal housing (W · H · D) 239 mm · 84.6 mm · 224 mm
Operating temperature	0° to 45° C (32° to 113° F)
Storage temperature	-20 °C to 70 °C (-4 °F to 158 °F)
Weight	Approx. 1.5 kg (3.3 lb)
Relative humidity	< 75% annual average < 90% in rare cases
Power supply	Primary-clocked power supply 100 Vac to 240 Vac (-15% to +10%) 50 Hz to 60 Hz (± 2 Hz)
Line fuse	F 1 A inside the housing
Power consumption	8 W (typically)
Electromagnetic	

Noise immunity	As per VDE 0843 Parts 2 and 4, severity 4
Protection	IP40 according to IEC 529
Encoder inputs	For linear and angle encoders with sinusoidal output signals (11 μ A _{PP} /1 V _{PP}); Reference mark evaluation for distance- coded and single reference marks
Input frequency	X1 11 μ A _{PP} : Max. 500 kHz for 60 m cable length X2 1 V _{PP} : Max. 100 kHz for 30 m cable length
Display step	Adjustable
Datum points	Two
Functions	<ul style="list-style-type: none"> • Series of measurements ¹⁾ • Sorting and tolerance checking • Switching and sorting signals • Set display and reset display to zero with external signal • Measured value output
RS-232-C/V.24 Interface	Baud rates: 110, 150, 300, 600, 1200, 2400, 4800, 9600, 19 200, 38 400 baud

¹⁾ Only in linear measurement mode.

ND 281 B: Dimensions in mm/inches

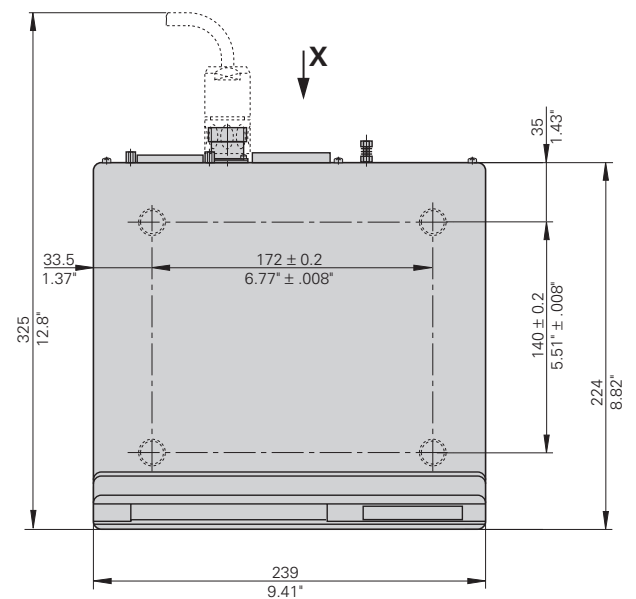
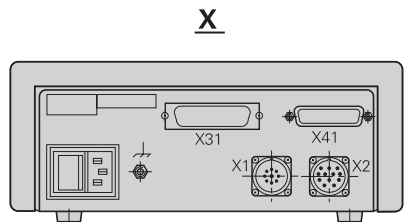
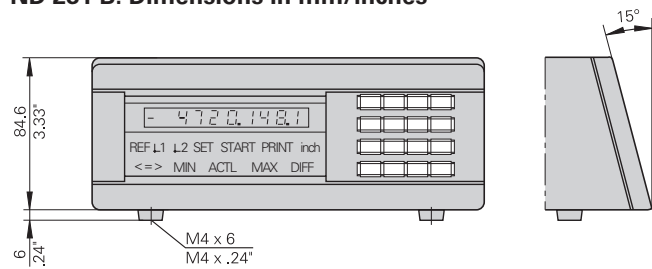

HEIDENHAIN

DR. JOHANNES HEIDENHAIN GmbH

Dr.-Johannes-Heidenhain-Straße 5

83301 Traunreut, Germany

 + 49/86 69/31-0

 + 49/86 69/50 61

e-mail: info@heidenhain.de

 **Service** + 49/86 69/31-12 72

 TNC-Service + 49/86 69/31-14 46

 + 49/86 69/98 99

e-mail: service@heidenhain.de

<http://www.heidenhain.de>

HEIDENHAIN (G.B.) Limited

200 London Road, Burgess Hill

West Sussex RH15 9RD, Great Britain

 (014 44) 24 77 11

 (014 44) 87 00 24