

Warnhinweise · Warnings

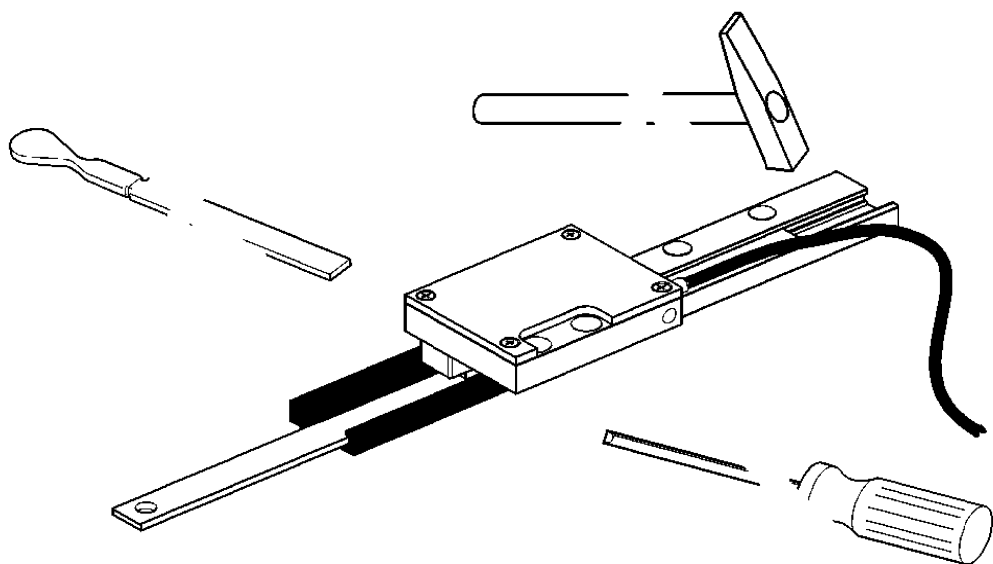

DIN EN 100 015 - 1
CECC 00015 - 1

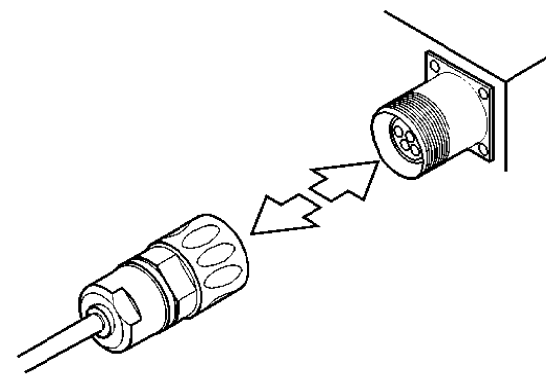
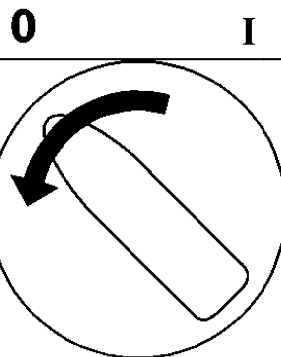
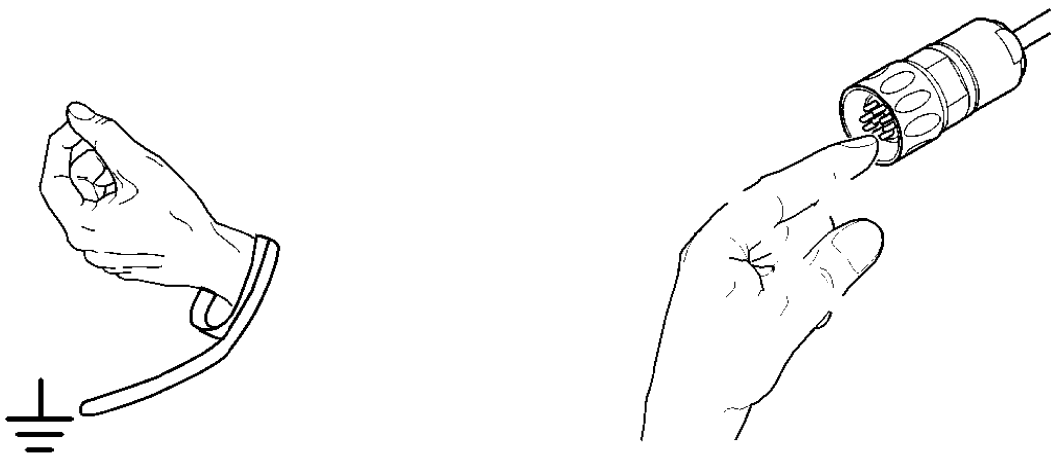

sauber halten
Keep clean

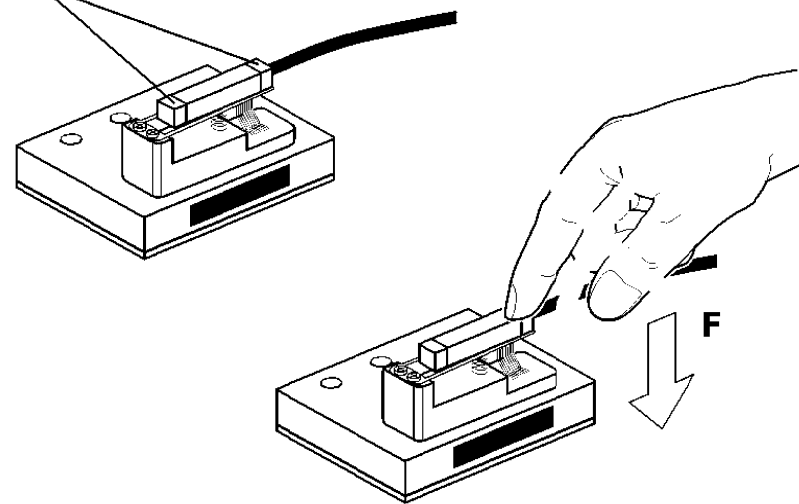

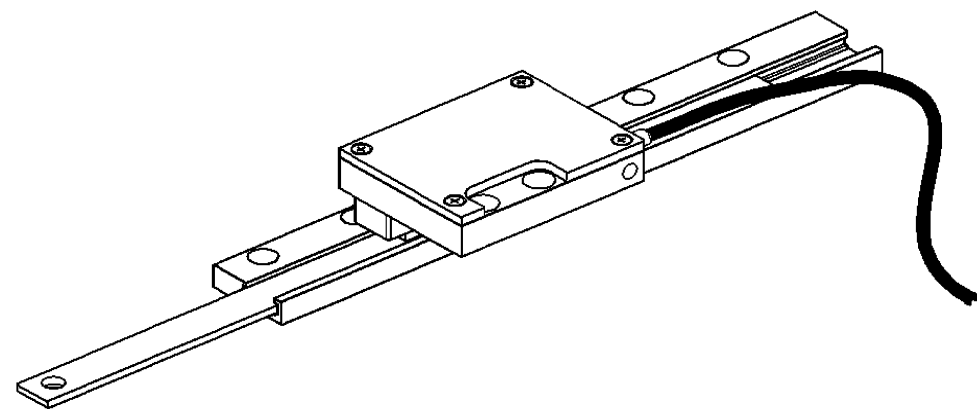
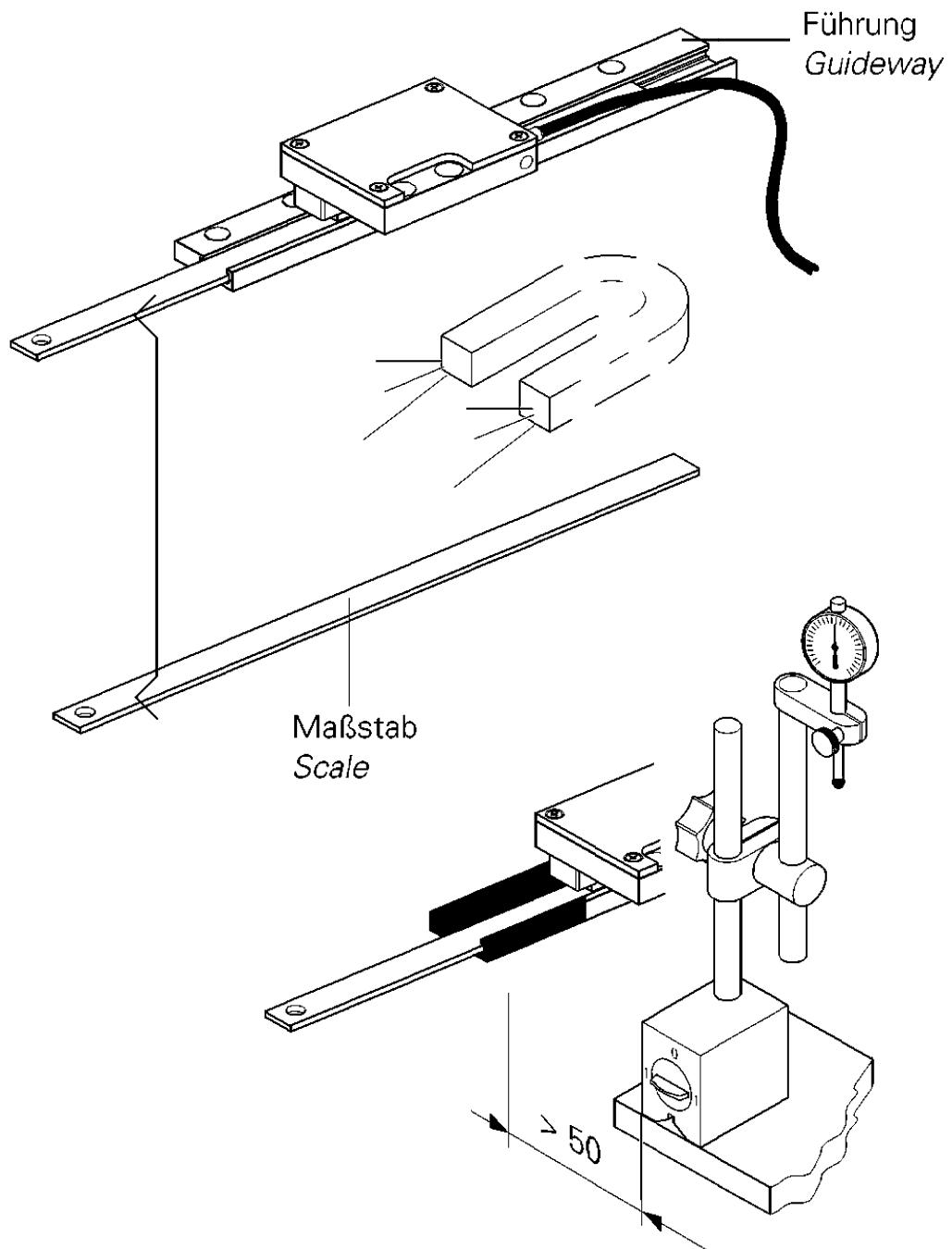

Austausch des Maßstabs nur mit Führung
Scale can only be exchanged together with the guideway

Anbau des Maßstabs · Mounting the Scale

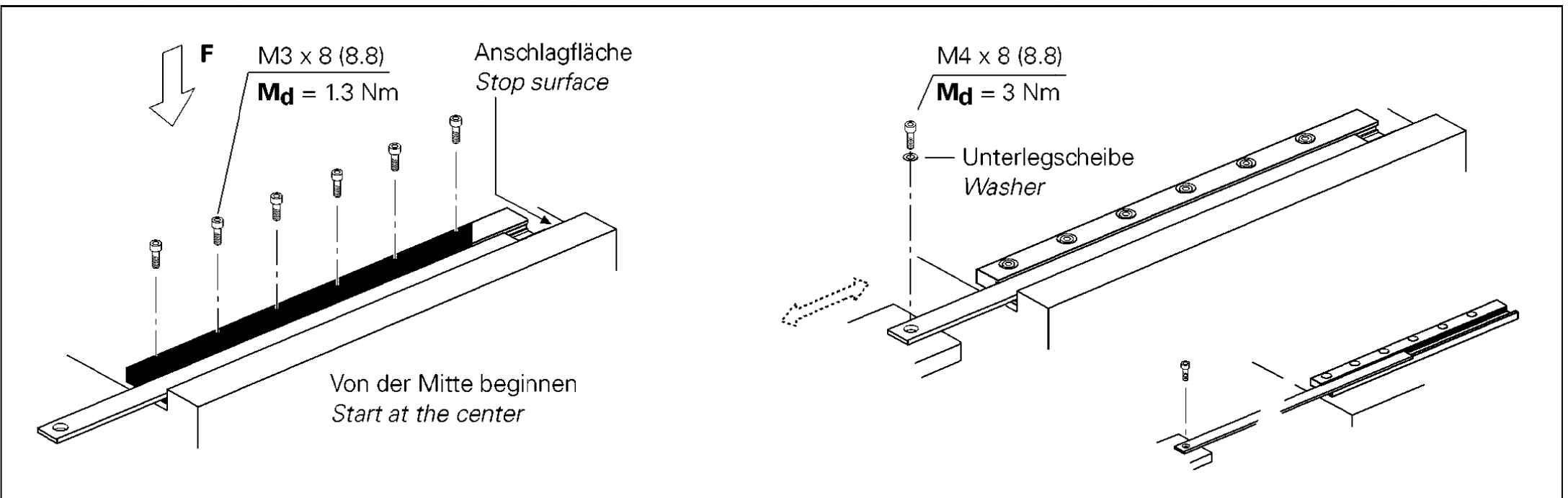
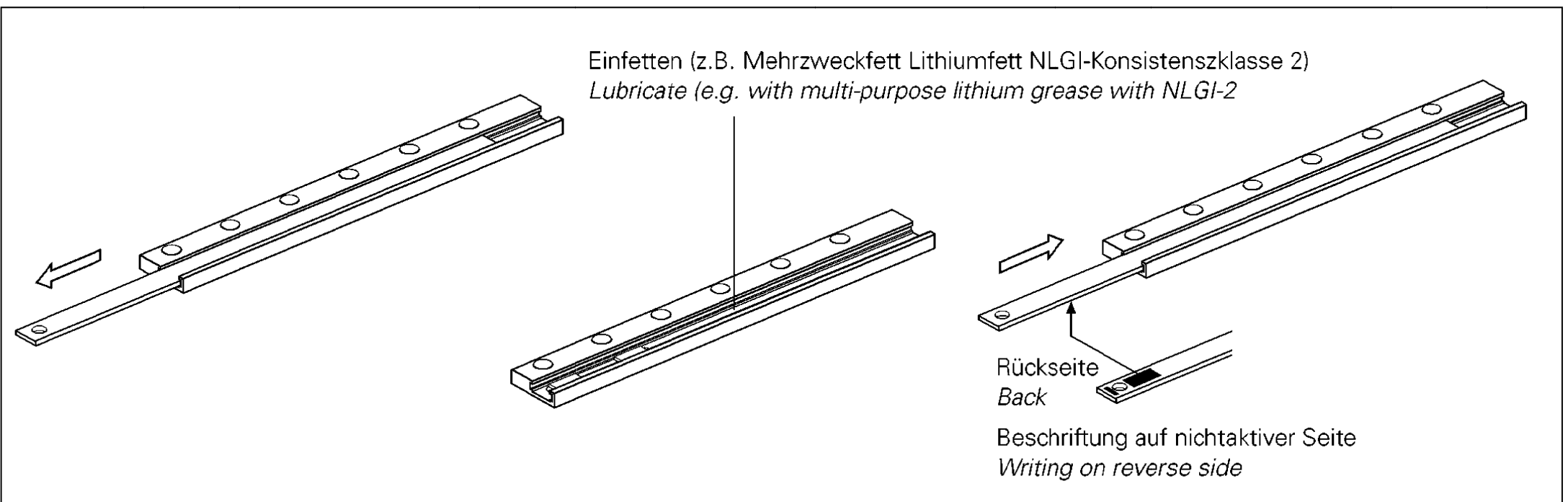

Anbau des Abtastkopfes · Mounting the Scanning Head

