



HEIDENHAIN

Exposed Linear Encoders

Exposed linear encoders

Linear encoders measure the position of linear axes without additional mechanical transfer elements. A number of potential error sources are thereby eliminated:

- Positioning error due to heat generation in the recirculating ball screw
- Reversal error
- Kinematic error through the ball-screw pitch error

Linear encoders are therefore indispensable for machine tools on which high **positioning accuracy** and a high **machining rate** are essential.

Exposed linear encoders are used on machines and equipment that require high measuring accuracy. Typical applications include the following:

- Measuring and production equipment in the semiconductor industry
- PCB assembly machines
- Ultra-precision machines and devices such as diamond lathes for optical components, facing lathes for magnetic storage disks, and grinding machines for ferrite components
- High-accuracy machine tools
- Measuring machines and comparators, measuring microscopes, and other precision measuring devices
- Direct drive motors

Mechanical design

Exposed linear encoders consist of a scale or scale tape and a scanning head that operate without mechanical contact. The scales of exposed linear encoders are fastened to a mounting surface. High flatness of the mounting surface is thus an important requirement for the high accuracy of linear encoders.

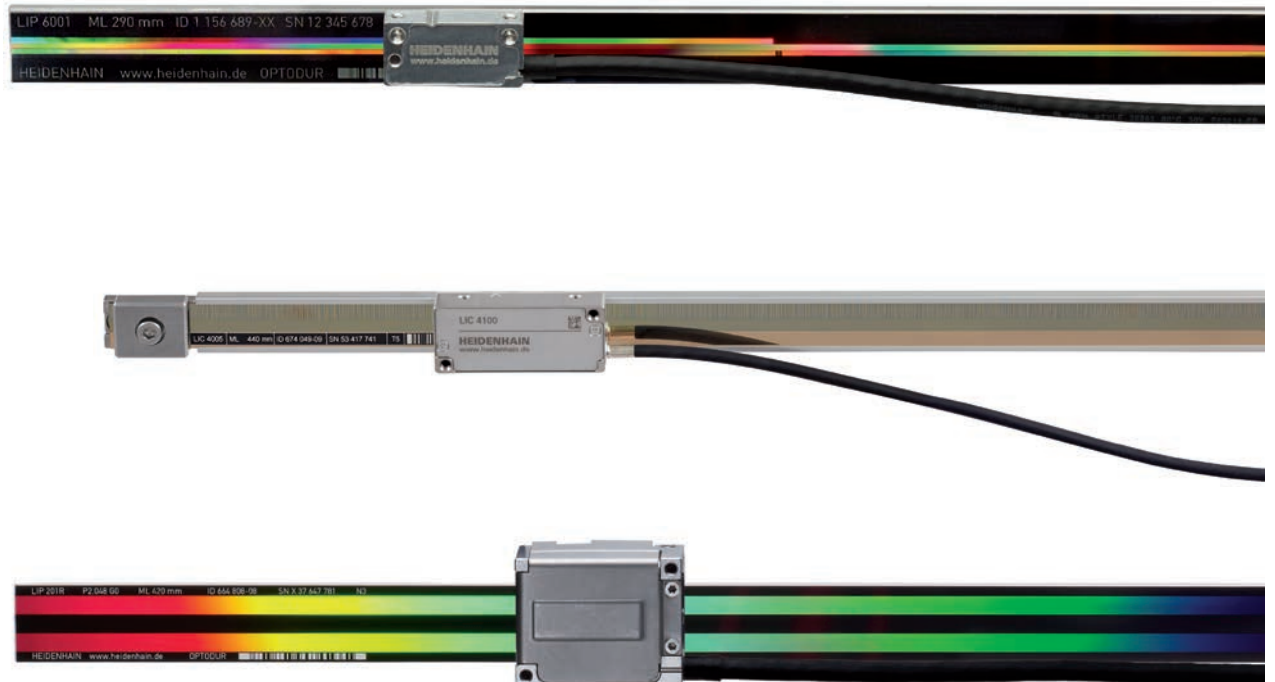

Information on the following topics is available upon request or on the Internet at www.heidenhain.com:

- Angle encoders with integral bearing
- Modular angle encoders with optical scanning
- Modular angle encoders with magnetic scanning
- Rotary encoders
- Encoders for servo drives
- Linear encoders for numerically controlled machine tools
- Interface electronics
- HEIDENHAIN controls

This brochure supersedes all previous editions, which thereby become invalid. The basis for ordering from HEIDENHAIN is always the brochure edition valid when the order is placed.

Standards (ISO, EN, etc.) apply only where explicitly stated in the brochure.



Further information:

For detailed descriptions of all available interfaces, as well as general electrical information, please refer to the *Interfaces of HEIDENHAIN Encoders* brochure (ID 1078628-xx).

For the required cables, please refer to the *Cables and Connectors* brochure (ID 1206103-xx).

Contents

Overview		
	Exposed linear encoders	2
	Selection guide	4
Technical characteristics		
	Measuring principles	8
	Reliability	12
	Measuring accuracy	14
	Mechanical design types and mounting	17
	General mechanical information	21
	Functional safety	22
Specifications		
For absolute position measurement	LIC 4113, LIC 4193	24
	LIC 4115, LIC 4195	26
	LIC 4117, LIC 4197	28
	LIC 4119, LIC 4199	30
	LIC 4119FS 	32
	LIC 3117, LIC 3197	34
	LIC 3119, LIC 3199	36
	LIC 2117, LIC 2197	38
	LIC 2119, LIC 2199	40
For high accuracy	LIP 382	42
	LIP 211, LIP 281, LIP 291	44
	LIP 6071, LIP 6081	46
	LIF 471, LIF 481	48
For high traversing speed	LIDA 473, LIDA 483	50
	LIDA 475, LIDA 485	52
	LIDA 477, LIDA 487	54
	LIDA 479, LIDA 489	56
	LIDA 277, LIDA 287	58
	LIDA 279, LIDA 289	60
For two-coordinate measurement	PP 281 R	62
Electrical connection		
	Interfaces	64
	Testing equipment and diagnostics	71
	Interface electronics	73

Selection guide

Absolute encoders

Absolute position measurement

The LIC exposed linear encoders permit absolute position measurement over long traverse paths of up to 28 m at high traversing speed.

Encoders for use in a vacuum environment

HEIDENHAIN standard encoders are suitable for use in rough or fine vacuums. Encoders used in high and ultrahigh vacuums must meet special requirements. The design and materials used for such encoders must be specifically tailored to these conditions. For more information, please refer to the *Linear Encoders for Vacuum Technology* Technical Information document.

The LIC 4113V and LIC 4193V linear encoders are specifically designed for use in high vacuums. For more information, please refer to the appropriate Product Information documents.

	Baseline error		Substrate and mounting
	Accuracy grade	Interval	
LIC 4100 For very high accuracy	±1 µm ¹⁾ ±3 µm ±5 µm	≤ ±0.275 µm/ 10 mm	Glass or glass ceramic scale, adhesively bonded to the mounting surface or fastened with fixing clamps
	±5 µm	≤ ±0.750 µm/ 50 mm (typical)	Steel scale tape pulled through aluminum extrusions and tensioned
	±3 µm ±5 µm ²⁾ ±15 µm ²⁾	≤ ±0.750 µm/ 50 mm (typical)	Steel scale tape pulled through aluminum extrusions and secured
	±3 µm ±15 µm ³⁾	≤ ±0.750 µm/ 50 mm (typical)	Steel scale tape, adhesively bonded to mounting surface
LIC 3100 For high accuracy	±15 µm ³⁾	≤ ±0.750 µm/ 50 mm (typical)	Steel scale tape pulled through aluminum extrusions and fastened at center
			Steel scale tape, adhesively bonded to mounting surface
LIC 2100 For simple mounting	±15 µm	–	Steel scale tape pulled through aluminum extrusions and secured
	±15 µm	–	Steel scale tape, adhesively bonded to mounting surface

¹⁾ Up to a measuring length (ML) of 1640 mm

²⁾ For a measuring length (ML) of 1240 mm or greater

	Interpolation error	Measuring length	Interface	Model	Page
	±20 nm	240 mm to 3040 mm	EnDat 2.2	LIC 4113 LIC 4113V	24
			5)	LIC 4193 LIC 4193V	
	±20 nm	140 mm to 28440 mm	EnDat 2.2	LIC 4115	26
			5)	LIC 4195	
	±20 nm	240 mm to 6040 mm	EnDat 2.2	LIC 4117	28
			5)	LIC 4197	
	±20 nm	70 mm to 1020 mm	EnDat 2.2	LIC 4119	30
		5)	LIC 4199		
		70 mm to 1820 mm	EnDat 2.2	LIC 4119 	32
	±100 nm	Up to 10000 mm	EnDat 2.2	LIC 3117	34
			5)	LIC 3197	
			EnDat 2.2	LIC 3119	
			5)	LIC 3199	
	±2 µm	120 mm to 3020 mm	EnDat 2.2	LIC 2117	38
			5)	LIC 2197	
	±2 µm	120 mm to 3020 mm	EnDat 2.2	LIC 2119	40
			5)	LIC 2199	

3) ±5 µm after linear length-error compensation in the subsequent electronics

4) With HEIDENHAIN interface electronics

5) Fanuc α i, Mitsubishi, Panasonic, Yaskawa



Selection guide

Incremental encoders

Very high accuracy

The **LIP** exposed linear encoders are characterized by their very small measuring steps combined with extremely high accuracy and repeatability. They utilize the interferential scanning principle and feature an OPTODUR phase grating as their measuring standard. The LIP 211 and LIP 291 linear encoders output the position information as a position value. For this to occur, the sinusoidal scanning signals are highly interpolated in the scanning head and converted into a position value by the integrated counter function. As with all incremental encoders, the absolute reference is established by means of reference marks.

High accuracy

The **LIF** exposed linear encoders utilize the interferential scanning principle and possess a measuring standard made with the SUPRADUR process. They feature high accuracy and repeatability, are particularly easy to mount, and are equipped with limit switches and homing tracks. The special version LIF 481 V can be used in high vacuums of up to 10^{-7} millibars (see separate Product Information document).

High traversing speeds

The **LIDA** exposed linear encoders are designed for high traversing speeds of up to 10 m/s. Their various mounting options allow for particularly flexible deployment. Depending on the version, steel scale tapes, glass, or glass ceramic are used as the carriers for METALLUR gratings. They also feature limit switches.

Two-coordinate measurement

The measuring standard of the **PP** two-coordinate encoder is an interferentially scanned planar phase grating manufactured with the DIADUR process. Position measurement is thereby possible within a plane.

	Baseline error		Substrate and mounting
	Accuracy grade ¹⁾	Interval	
LIP For very high accuracy	$\pm 0.5 \mu\text{m}^{3)}$	$\leq \pm 0.075 \mu\text{m}/$ 5 mm	Zerodur glass ceramic embedded within a screw-on Invar carrier
	$\pm 1 \mu\text{m}^{2)}$ $\pm 3 \mu\text{m}$	$\leq \pm 0.125 \mu\text{m}/$ 5 mm	Scale made of Zerodur glass ceramic, fastened with fixing clamps
	$\pm 1 \mu\text{m}^{5)}$ $\pm 3 \mu\text{m}$	$\leq \pm 0.175 \mu\text{m}/$ 5 mm	Scale made of Zerodur glass ceramic or glass, adhesively bonded or fastened with fixing clamps
LIF For high accuracy	$\pm 1 \mu\text{m}^{8)}$ $\pm 3 \mu\text{m}$	$\leq \pm 0.175 \mu\text{m}/$ 5 mm	Scale made of Zerodur glass ceramic or glass, adhesively bonded or fastened with fixing clamps
	$\pm 1 \mu\text{m}^{5)}$ $\pm 3 \mu\text{m}$	$\leq \pm 0.225 \mu\text{m}/$ 5 mm	Scale made of Zerodur glass ceramic or glass, adhesively bonded by means of PRECIMET adhesive mounting film
LIDA For high traversing speeds and large measuring lengths	$\pm 1 \mu\text{m}^{9)}$ $\pm 3 \mu\text{m}$ $\pm 5 \mu\text{m}$	$\leq \pm 0.275 \mu\text{m}/$ 10 mm	Scale made of glass ceramic or glass, adhesively bonded to the mounting surface
	$\pm 5 \mu\text{m}$	$\leq \pm 0.750 \mu\text{m}/$ 50 mm (typical)	Steel scale tape pulled through aluminum extrusions and tensioned
	$\pm 3 \mu\text{m}^{2)}$ $\pm 5 \mu\text{m}$ $\pm 15 \mu\text{m}^{6)}$	$\leq \pm 0.750 \mu\text{m}/$ 50 mm (typical)	Steel scale tape pulled through aluminum extrusions and secured
	$\pm 3 \mu\text{m}^{2)}$ $\pm 15 \mu\text{m}^{6)}$	$\leq \pm 0.750 \mu\text{m}/$ 50 mm (typical)	Steel scale tape, adhesively bonded to mounting surface
	$\pm 15 \mu\text{m}$	–	Steel scale tape pulled through aluminum extrusions and secured
	$\pm 15 \mu\text{m}$	–	Steel scale tape, adhesively bonded to mounting surface
PP For two-coordinate measurement	$\pm 2 \mu\text{m}$	–	Glass grid plate, secured with full-surface adhesive bond

¹⁾ At an interval of 1 m or a measuring length < 1 m (accuracy grade)

²⁾ Up to a measuring length of 1020 mm or 1040 mm

³⁾ Higher accuracy grades upon request

⁴⁾ Other measuring lengths / measuring areas upon request

	Interpolation error	Signal period	Measuring length	Interface	Model	Page
	±0.01 nm	0.128 μm	70 mm to 270 mm	~ 1 V _{PP}	LIP 382	42
	±0.4 nm ⁷⁾	0.512 μm	20 mm to 3040 mm	EnDat 2.2	LIP 211	44
~ 1 V _{PP}				LIP 281		
Fanuc Pi Mitsubishi				LIP 291		
	– ±4 nm	4 μm	20 mm to 3040 mm	□TTL	LIP 6071	46
				~ 1 V _{PP}	LIP 6081	
	– ±12 nm	4 μm	70 mm to 3040 mm ⁴⁾	□TTL	LIF 171	Product Information
				~ 1 V _{PP}	LIF 181	
	– ±12 nm	4 μm	70 mm to 1640 mm	□TTL	LIF 471	48
				~ 1 V _{PP}	LIF 481 LIF 481V	
	– ±45 nm	20 μm	240 mm to 3040 mm	□TTL	LIDA 473	50
				~ 1 V _{PP}	LIDA 483	
	– ±45 nm	20 μm	140 mm to 30 040 mm	□TTL	LIDA 475	52
				~ 1 V _{PP}	LIDA 485	
	– ±45 nm	20 μm	240 mm to 6040 mm	□TTL	LIDA 477	54
				~ 1 V _{PP}	LIDA 487	
	– ±45 nm	20 μm	Up to 6000 mm ⁴⁾	□TTL	LIDA 479	56
				~ 1 V _{PP}	LIDA 489	
	– ±2 μm	200 μm	Up to 10 000 mm ⁴⁾	□TTL	LIDA 277	58
				~ 1 V _{PP}	LIDA 287	
	– ±2 μm	200 μm	Up to 10 000 mm ⁴⁾	□TTL	LIDA 279	60
				~ 1 V _{PP}	LIDA 289	
	±12 nm ⁷⁾	4 μm	Measuring area: 68 x 68 mm ⁴⁾	~ 1 V _{PP}	PP 281	62

⁵⁾ Only for Zerodur glass ceramic up to a measuring length of 1020 mm

⁶⁾ ±5 μm after linear length-error compensation in the subsequent electronics

⁷⁾ With HEIDENHAIN interface electronics

⁸⁾ Up to a measuring length of 1640 mm

⁹⁾ Only for Robax glass ceramic up to a measuring length of 1640 mm

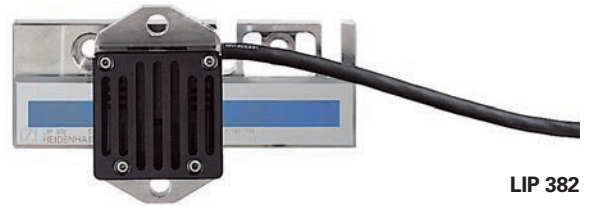

LIP 382



LIP 281



LIP 6081



LIF 481



LIDA 489



LIDA 287

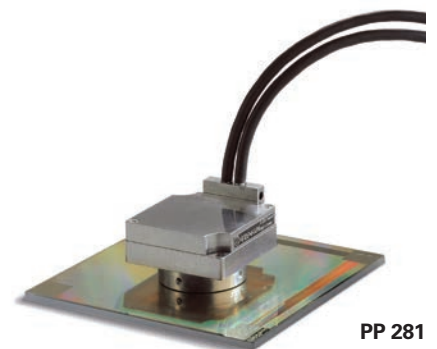

PP 281

Measuring principles

Measuring standard

HEIDENHAIN encoders with optical scanning incorporate measuring standards consisting of periodic structures known as graduations. These graduations are applied to a carrier substrate made of glass or steel. For encoders with large measuring lengths, steel tape is used as the scale substrate.

HEIDENHAIN manufactures the precision graduations in the following specially developed, photolithographic processes:

- METALLUR: contamination-tolerant graduation consisting of metal lines on gold; typical grating period: 20 μm
- SUPRADUR phase grating: optically three-dimensional, planar structure; particularly tolerant to contamination; typical grating period: 8 μm and finer
- OPTODUR phase grating: optically three-dimensional, planar structure with particularly high reflectance; typical grating period: 2 μm and finer
- TITANID phase grating: exceptionally robust, optically three-dimensional structure with a high degree of reflectance; typical grating period: 8 μm

Along with the very fine grating periods, these processes permit high edge definition and excellent homogeneity of the graduation. In combination with the photoelectric scanning method, these characteristics are crucial for attaining high-quality output signals.

The master graduations are manufactured by HEIDENHAIN on custom-built, high-precision dividing engines.

Absolute measuring method

With the absolute measuring method, the position value is available immediately upon switch-on of the encoder and can be requested at any time by the subsequent electronics. There is no need to move the axes to find the reference position. The absolute position information is read **from the graduation on the measuring standard**, which is designed as a serial absolute code structure. A separate incremental track is interpolated for the position value and, depending on the interface version, is also used to generate an optional incremental signal.

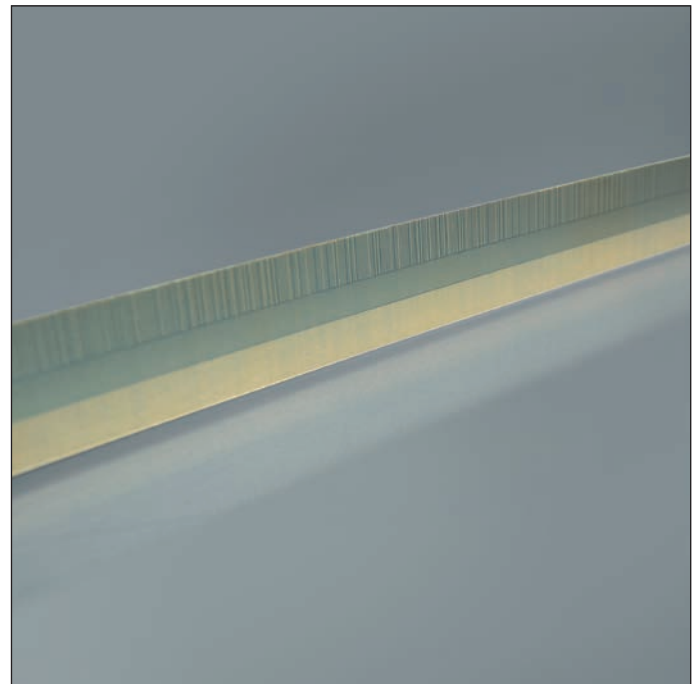

Graduation of an absolute linear encoder

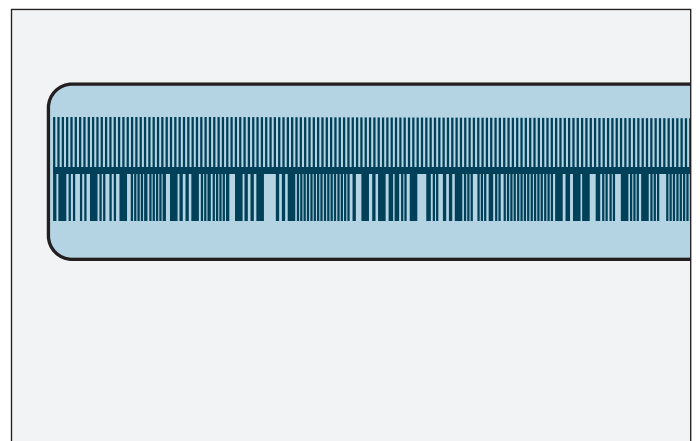

Schematic representation of a code structure with an additional incremental track (example from the LIC 411x)

Incremental measuring method

With the incremental measuring method, the graduation consists of a periodic grating structure. The position information is obtained **by counting** the individual increments (measuring steps) from some point of origin. Since an absolute reference is required to ascertain positions, the measuring standard is provided with an additional track that bears a **reference mark**. The absolute position on the scale, which is established by the reference mark, is assigned to exactly one signal period. Thus, before an absolute reference can be established or the most recently selected reference point can be refound, this reference mark must first be traversed.

In the most unfavorable case, machine movements over sizeable sections of the measuring range may be necessary. To speed up and simplify such "reference runs," many HEIDENHAIN encoders feature **distance-coded reference marks**—multiple reference marks that are individually spaced in accordance with a mathematical algorithm. The subsequent electronics find the absolute reference after traversing two successive reference marks—thus after a traverse path of only a few millimeters (see table below).

Encoders with distance-coded reference marks are identified with a "C" following the model designation (e.g., LIF 181 C).

With distance-coded reference marks, the **absolute reference R** is calculated by counting the increments between two reference marks and by applying the following formula:

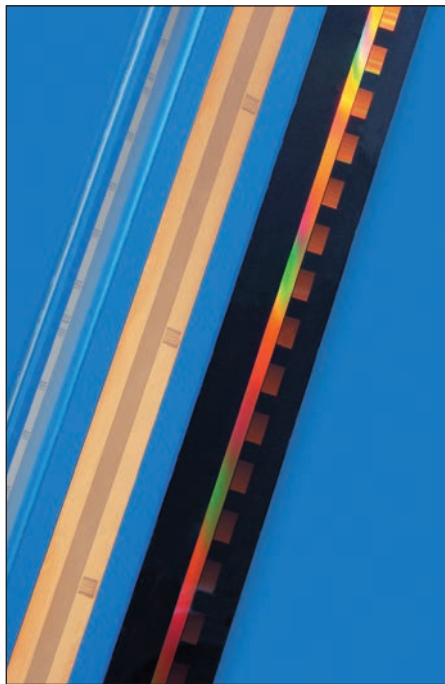

Graduations of incremental linear encoders

$$P_1 = (\text{abs } R - \text{sgn } R - 1) \times \frac{N}{2} + (\text{sgn } R - \text{sgn } D) \times \frac{\text{abs } M_{RR}}{2}$$

and

$$R = 2 \times M_{RR} - N$$

Where:

P_1 = Position of the first traversed reference mark in signal periods

abs = Absolute value

sgn = Algebraic sign function (" +1 " or " -1 ")

M_{RR} = Number of signal periods between the traversed reference marks

N = Nominal increment between two fixed reference marks in signal periods (see table below)

D = Direction of traverse (+1 or -1). Traverse of scanning unit to the right (when properly installed) equals +1

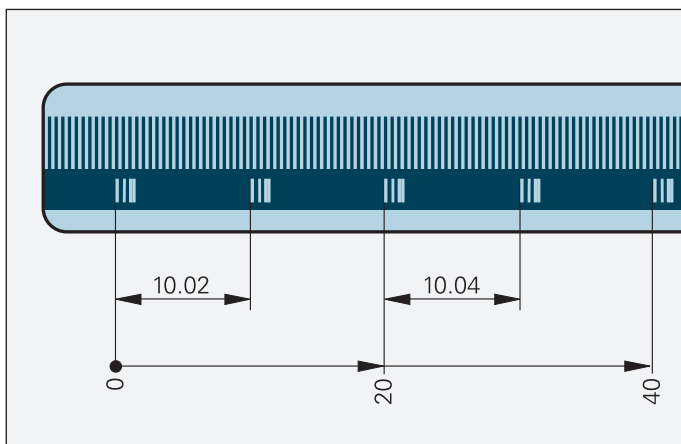

Schematic representation of an incremental graduation with distance-coded reference marks (example from the LIDA 4x3C)

	Signal period	Nominal increment N in signal periods	Maximum traverse
LIF 1x1C	4 μm	5000	20 mm
LIDA 4x3C	20 μm	1000	20 mm

Photoelectric scanning

Most HEIDENHAIN encoders utilize the photoelectric scanning principle. Photoelectric scanning is performed contact-free and thus does not induce wear. This method detects even extremely fine graduation lines down to a width of only a few micrometers and generates output signals with very small signal periods.

The finer the grating period of a measuring standard is, the greater the effect of diffraction on photoelectric scanning. HEIDENHAIN linear encoders employ two scanning principles:

- The **imaging scanning principle** for grating periods from 10 μm to 200 μm
- The **interferential scanning principle** for very fine grating periods of 4 μm and smaller

Imaging scanning principle

Put simply, the imaging scanning principle uses projected-light signal generation: two gratings with, for example, equal or similar grating periods—the scale and the scanning reticle—are moved relative to each other. The carrier material of the scanning reticle is transparent, whereas the graduation of the measuring standard may likewise be applied to a transparent material or to a reflective material.

When parallel light passes through a grating structure, light and dark fields are projected at a certain interval. At this location there is an index grating with the same or similar grating period. When the two gratings move relative to each other, the incident light is modulated: If the gaps are aligned, light passes through. If the lines of one grating coincide with the gaps of the other, no light passes through. Photocells convert these light fluctuations into electrical signals. The specially structured grating of the scanning reticle filters the light to generate nearly sinusoidal output signals. The smaller the grating period of the grating structure is, the closer and more tightly tolerated the gap must be between the scanning reticle and the scale. In encoders that use the imaging scanning principle, workable mounting tolerances are attainable starting at a minimum grating period of 10 μm .

The **LIC** and **LIDA** linear encoders use the imaging scanning principle.

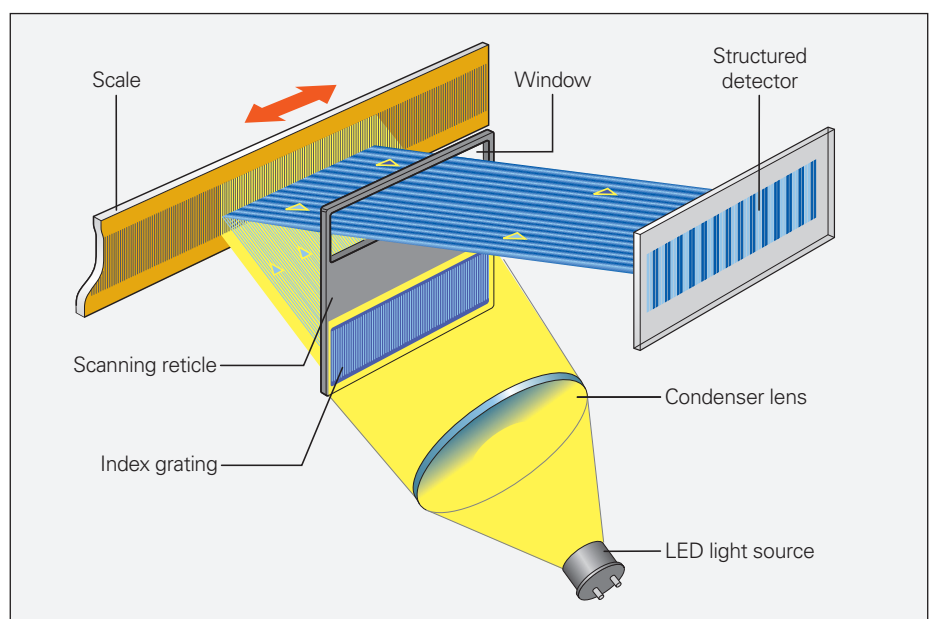
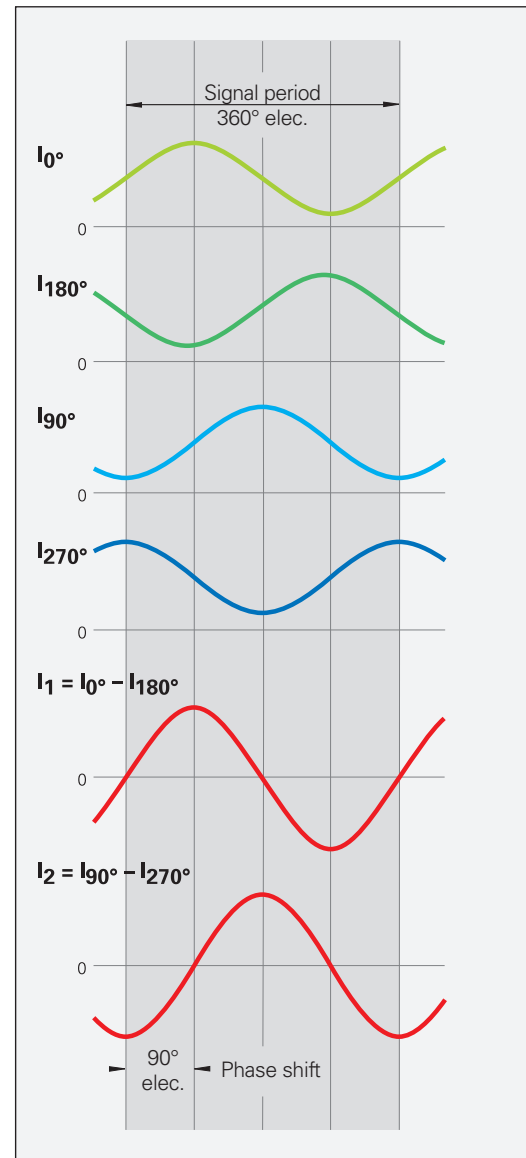

Photoelectric scanning in accordance with the imaging principle with a steel scale and single-field scanning (LIDA 400)

The sensor generates four nearly sinusoidal current signals (I_{0° , I_{90° , I_{180° , and I_{270°), phase-shifted to each other by 90° elec. These scanning signals do not initially exhibit symmetry about the zero line. For this reason, the photocells are connected in anti-parallel, thereby producing two 90° elec. phase-shifted output signals, **I1** and **I2**, which are symmetrical about the zero line.

In the X/Y representation on an oscilloscope, the signals form a Lissajous figure. Ideal output signals appear as a centered circle. Deviations in the circular form and position are caused by position errors and therefore go directly into the result of measurement. The size of the circle, which corresponds to the amplitude of the output signal, can vary within certain limits without influencing the measuring accuracy.

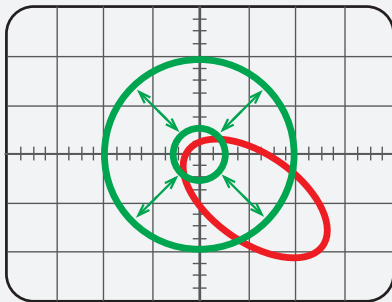

X/Y representation of the output signals

Interferential scanning principle

The interferential scanning principle exploits the diffraction and interference of light on finely divided gratings in order to produce the signals used to measure displacement.

A step grating is used as the measuring standard: reflective lines with a height of $0.2 \mu\text{m}$ are applied to a flat, reflective surface. In front of this is the scanning reticle—a transparent phase grating with the same grating period as the scale.

When a light wave passes through the scanning reticle, it is diffracted into three partial waves of the orders $+1$, 0 , and -1 , with nearly equal luminous intensity. The waves are diffracted by the scale such that most of the luminous intensity is found in the reflected diffraction orders $+1$ and -1 . These partial waves meet again at the phase grating of the scanning reticle, where they are diffracted again and interfere. This produces essentially three waves that leave the scanning reticle at different angles. Photocells convert these alternating light intensities into electrical signals.

When there is relative motion between the scale and the scanning reticle, the diffracted wavefronts undergo a phase shift: movement by the amount of one grating period shifts the positive first-order diffraction wavefront by one wavelength in the positive direction, while the negative first-order diffraction wavefront is displaced by one wavelength in the negative direction. Since the two waves interfere with each other upon exiting the phase grating, these waves are shifted relative to each other by two wavelengths. This results in two signal periods when there is relative motion of just one grating period.

Interferential encoders use grating periods of, for example, $8 \mu\text{m}$, $4 \mu\text{m}$, and finer. Their scanning signals are largely free of harmonics and can be highly interpolated. These encoders are therefore especially well-suited for small measuring steps and high accuracy. They nevertheless feature workable mounting tolerances.

The **LIP**, **LIF**, and **PP** linear encoders use the interferential scanning principle.

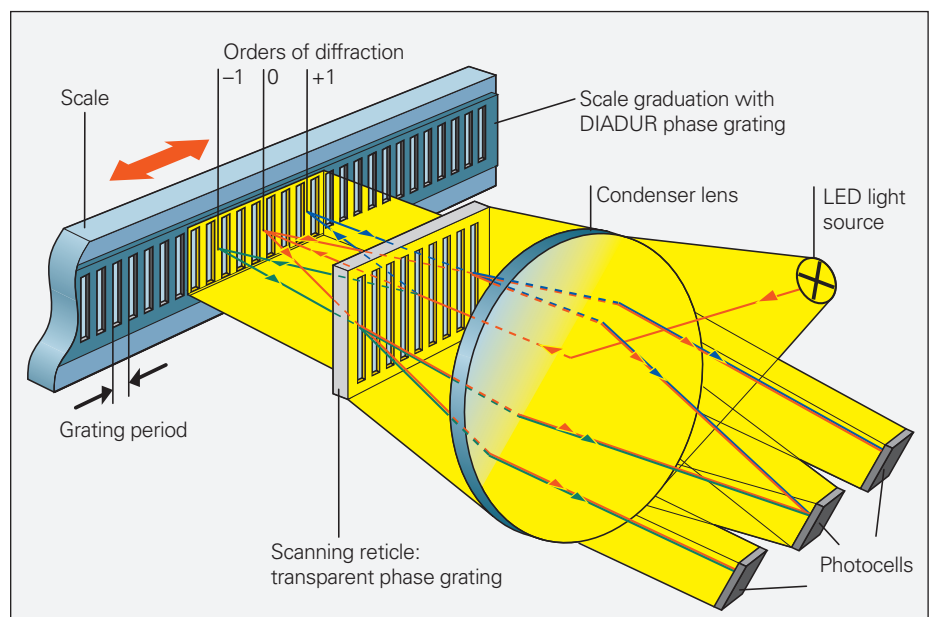

Photoelectric scanning in accordance with the interferential measuring principle and single-field scanning

Reliability

Exposed linear encoders from HEIDENHAIN are optimized for use on fast, precise machines. Despite their exposed mechanical design, these encoders are highly insensitive to contamination, ensure high long-term stability, and are quickly and easily mounted.

Lower sensitivity to contamination

Both the high quality of the grating and the scanning method are responsible for the accuracy and reliability of linear encoders. Exposed linear encoders from HEIDENHAIN employ **single-field scanning**, in which a single large scanning field is used to generate the scanning signals. Local contamination on the measuring standard (e.g., fingerprints from the mounting process or oil residues from guideways) has only a slight influence on the light intensity of the signal components and thus on the scanning signals. Although this contamination does cause a change in the amplitude of the output signals, their offset and phase position remain unaffected. The signals remain highly interpolable, and the position error within one signal period remains small.

The **large scanning field** further reduces the sensitivity to contamination. Depending on the nature of the contamination, this feature can even prevent encoder failure. This is particularly true of the LIDA 400 and LIF 400, which feature a very large scanning surface area (14.5 mm²) relative to their grating period. The same goes for the LIC 4100, which has a scanning surface area of 15.5 mm². Even in the case of contamination from printer's ink, PCB dust, or drops of water or oil of up to 3 mm in diameter, these encoders continue to provide high-quality signals. The position error remains far below the values specified for the accuracy grade of the scale.

The LIDA, LIF, and LIP 6000 encoders are equipped with the HSP 1.0 signal processor ASIC from HEIDENHAIN. This ASIC continuously monitors the scanning signal and compensates nearly completely for fluctuations in signal amplitude. If the signal amplitude decreases as the result of contamination on the scanning reticle or measuring standard, the ASIC reacts by increasing the LED current. The ensuing increase in LED light intensity barely raises the noise level, even in the case of strong signal stabilization. As a result, contamination has only a very slight influence on interpolation errors and the position noise.

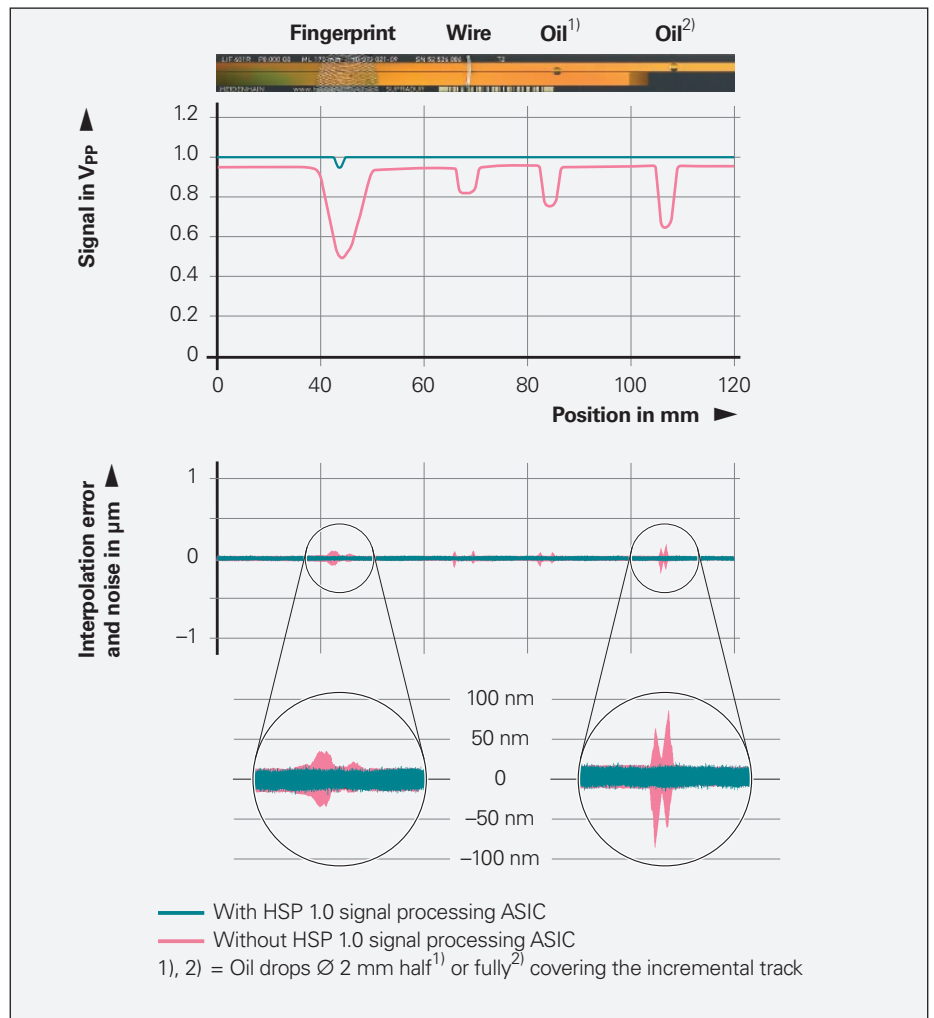
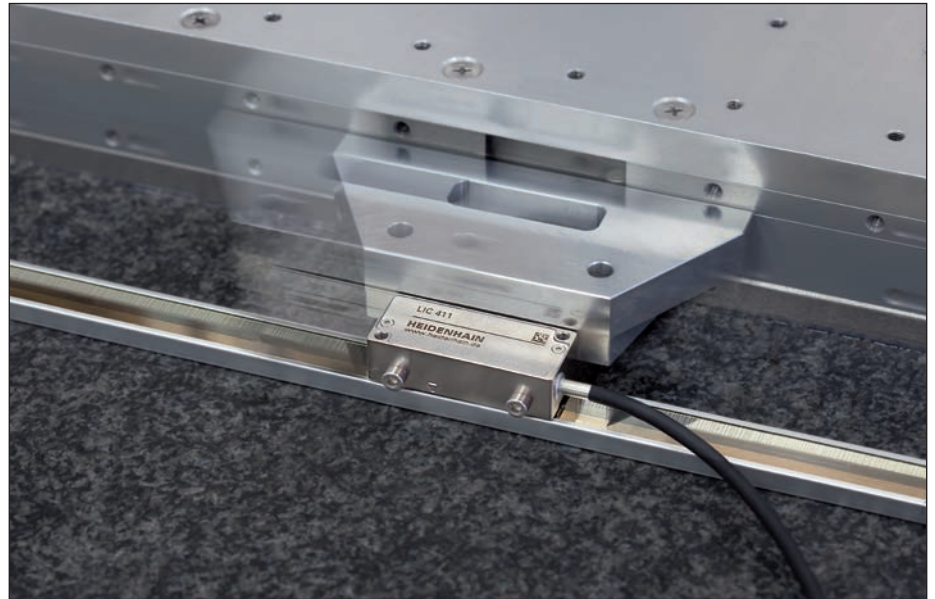

Measuring standard with contamination and the associated signal amplitudes with conventional scanning and scanning with the HSP 1.0 signal processing ASIC

Durable measuring standards

By nature of their design, the measuring standards of exposed linear encoders are less protected from their environment. For this reason, HEIDENHAIN always uses tough graduations manufactured in special processes.

In the OPTODUR and SUPRADUR processes, a transparent layer is first applied onto the reflective primary layer. For creating an optically three-dimensional phase grating, an extremely thin, hard chromium layer is applied at a thickness of only a few nanometers. The graduations for the imaging scanning principle exhibit a similar design and are manufactured in the METALLUR process. A reflective gold layer is covered with a thin layer of glass. On it are chromium lines acting as absorbers. Since they are only several nanometers thick, these lines are semitransparent. Measuring standards with OPTODUR, SUPRADUR, or METALLUR graduations have proven to be particularly robust and insensitive to contamination because the low height of their structure leaves practically no surface for dust, dirt, or water particles to accumulate.

Workable mounting tolerances

Very small signal periods usually come with very narrow mounting tolerances for the gap between the scanning head and scale tape. This is the result of diffraction caused by the grating structures. Such diffraction can lead to a signal attenuation of 50 % upon a gap change of only ± 0.1 mm. The interferential scanning principle and innovative index gratings on encoders that use the imaging principle allow for workable mounting tolerances despite tiny signal periods.

The mounting tolerances of exposed linear encoders from HEIDENHAIN have only a slight influence on the output signals. In particular, the specified distance tolerance between the scale and scanning head (scanning gap) causes only a negligible change in the signal amplitude. During operation, the reliability and stability of the signals are additionally improved by the HSP 1.0. The two diagrams illustrate the correlation between the scanning gap and signal amplitude for the encoders of the LIDA 400 and LIF 400 series.

OPTODUR
SUPRADUR

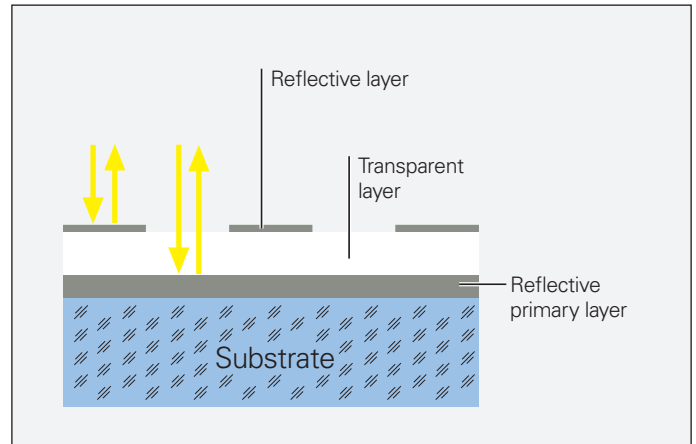

METALLUR

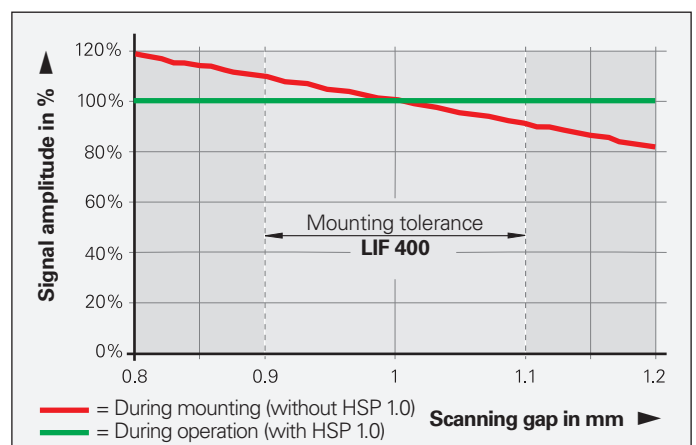
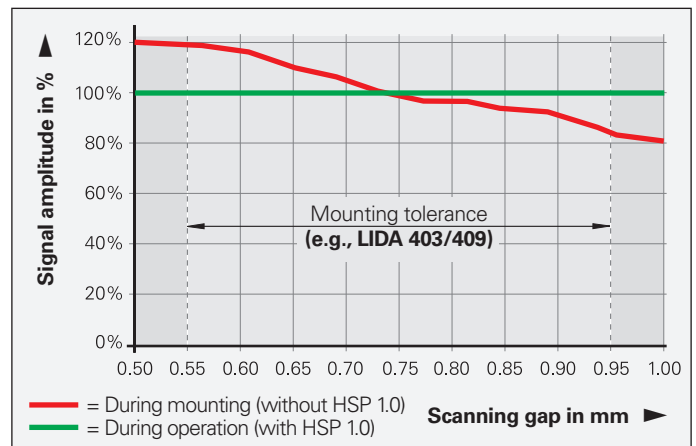
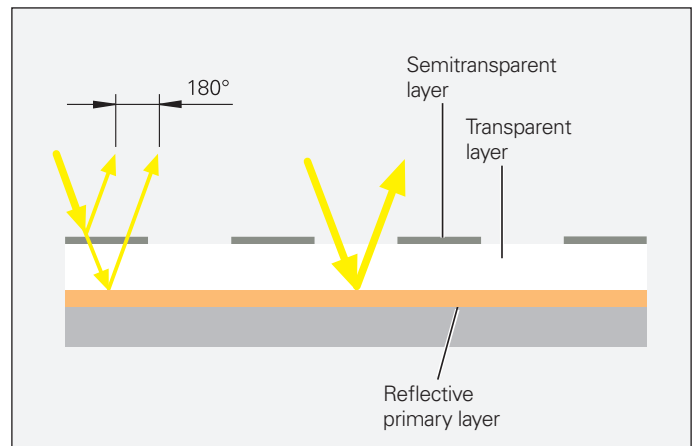

Measuring accuracy

The accuracy of the linear measurement is mainly determined by

- the quality of the graduation,
- the quality of the graduation carrier,
- the quality of the scanning process,
- the quality of the signal processing electronics, and by
- how the encoder is installed within the machine.

These factors can be subdivided into encoder-specific position errors and application-dependent factors. For assessment of the attainable system accuracy, all of the individual factors must be taken into account.

Encoder-specific position error

Encoder-specific position error includes

- the accuracy of the measuring standard,
- the accuracy of the interpolation, and
- the position noise.

Accuracy of the measuring standard

The accuracy of the measuring standard is mainly determined by

- the homogeneity and period definition of the graduation,
- the alignment of the graduation on its carrier, and
- the stability of the graduation carrier.

*The accuracy of the measuring standard is indicated by the uncompensated maximum value of the **baseline error**. This accuracy is ascertained under ideal conditions via measurement of the position errors with a serially produced scanning head. The distance between the measuring points is equivalent to the integer multiple of the signal period. As a result, interpolation errors have no effect.*

*The accuracy grade **a** defines the upper limit of the baseline error within any section of up to one meter in length. For special encoders, an additional baseline error is stated for defined intervals of the measuring standard.*

Accuracy of the interpolation

The accuracy of the interpolation is mainly influenced by

- the size of the signal period,
- the homogeneity and period definition of the graduation,
- the quality of scanning filter structures,
- the characteristics of the sensors, and
- the quality of the signal processing.

*The accuracy of the interpolation is ascertained with a serially produced measuring standard and is indicated by a typical maximum value **u** of the interpolation error. Encoders with an analog interface are tested with a HEIDENHAIN electronic device (e.g., EIB 741). The maximum values do not include position noise and are indicated in the specifications.*

The interpolation error already has an effect at very low traversing speeds and during repeated measurements. This error leads to fluctuations in the traversing speed, particularly within the speed control loop.

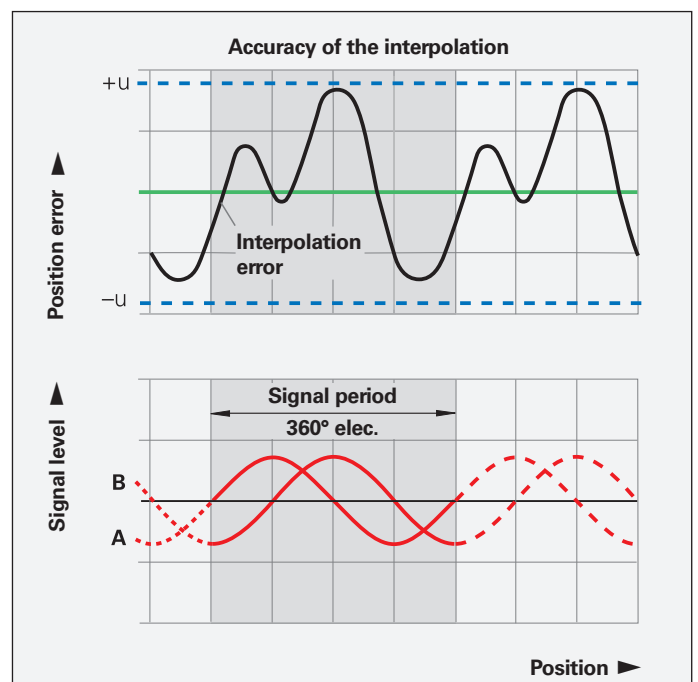
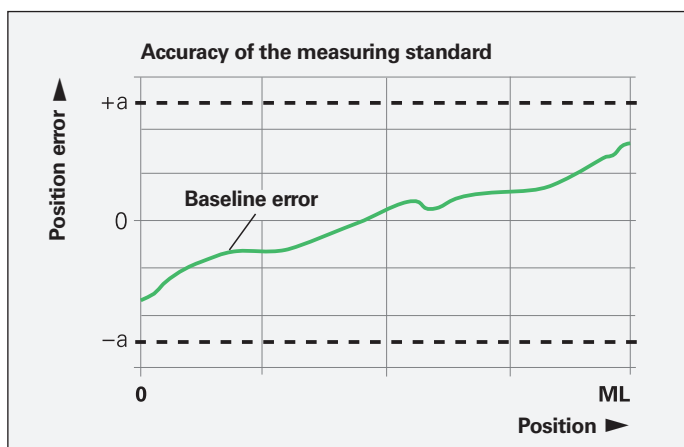

Position noise

Position noise is a random process leading to unpredictable position errors. The position values are grouped around an expected value in the form of a frequency distribution.

The amount of position noise depends on the signal processing bandwidths necessary for forming the position values. It is ascertained within a defined time interval and is stated as a product-specific RMS value.

In the speed control loop, position noise influences the speed stability at low traversing speeds.

Application-dependent position error

In the case of encoders without integral bearing, **installing the encoder in the machine** has a significant influence on the attainable overall accuracy beyond the specified encoder-specific position error. For assessment of the **overall accuracy**, the individual application-dependent errors must be measured and taken into account.

Deformation of the graduation

Errors due to a deformation of the graduation are not to be neglected. Such deformation occurs when the measuring standard is mounted on an uneven surface (e.g., a convex surface).

Mounting location

Poor mounting of linear encoders can aggravate the effect of guideway error on measuring accuracy. To keep the resulting Abbé error as small as possible, the scale should ideally be mounted to the machine slide and at the height of the table. It is important to ensure that the mounting surface is parallel to the machine guideway.

Vibration

To function properly, linear encoders must not be continuously subjected to strong vibration. The best mounting surfaces are therefore solid and stable machine elements. Encoders should not be mounted on hollow parts or with adapter blocks, etc.

Influence of temperature

In order to avoid temperature effects, the linear encoders should not be mounted in close proximity to heat sources.

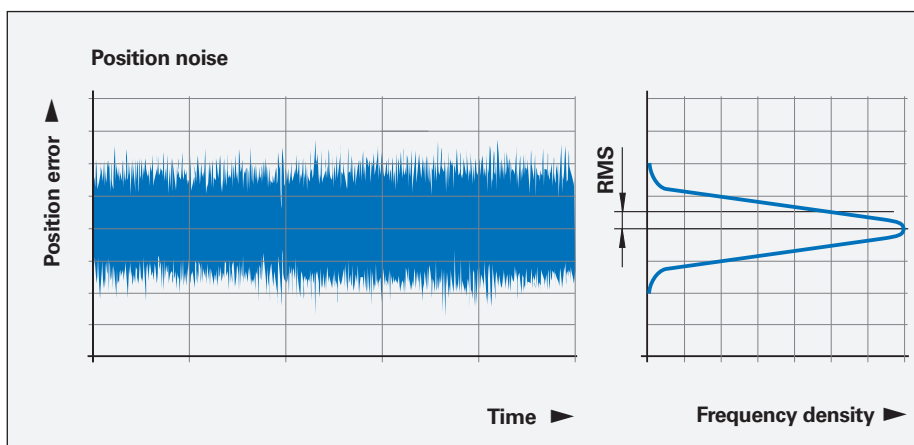

Calibration chart

All HEIDENHAIN linear encoders are inspected for accuracy and proper functioning prior to shipping.

The accuracy of the linear encoders is ascertained during traversing movements in both directions. The number of measuring positions is selected such that not only the long-range errors but also the position errors within a single signal period are very accurately determined.

The **Quality Inspection Certificate** confirms the specified accuracy grades of each encoder. The **calibration standards** ensure traceability to recognized national or international standards, such as required by EN ISO 9001.

For the LIP and PP encoder series, an additional calibration chart documents the ascertained **position error** over the measuring range. It also specifies the measuring parameters and the measurement uncertainty.

Temperature range

The linear encoders are calibrated at a **reference temperature** of 20 °C. The position error documented in the calibration chart is valid at this temperature.



HEIDENHAIN

LIP 201 R
ID 631000-13
SN 44408260

Qualitätsprüf-Zertifikat
DIN 55 350-18-4.2.2

Quality Inspection Certificate
DIN 55 350-18-4.2.2

Positionsabweichung F [µm]
Position error F [µm]

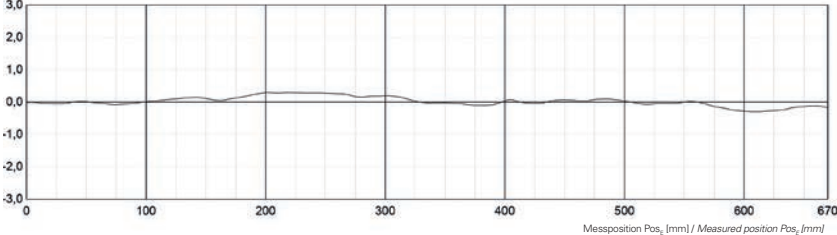

Messposition Pos_M [mm] / Measured position Pos_M [mm]

Die Messkurve zeigt die Mittelwerte der Positionsabweichungen aus Vorwärts- und Rückwärtsmessung.

Positionsabweichung F des Maßstab: $F = Pos_M - Pos_S$
 Pos_M = Messposition der Messmaschine
 Pos_S = Messposition des Maßstab

The error curve shows the mean values of the position errors from measurements in forward and backward direction.

Position error F of the scale: $F = Pos_M - Pos_S$
 Pos_M = position measured by the measuring machine
 Pos_S = position measured by the scale

Maximale Positionsabweichung der Messkurve	
innerhalb 670 mm	± 0,30 µm

Maximum position error of the error curve	
within 670 mm	± 0,30 µm

Unsicherheit der Messmaschine	
$U_{95\%} = 0,040 \mu\text{m} + 0,400 \cdot 10^{-4} \cdot L$ (L = Länge des Messintervalls)	

Uncertainty of measuring machine	
$U_{95\%} = 0,040 \mu\text{m} + 0,400 \cdot 10^{-4} \cdot L$ (L = measurement interval length)	

Messparameter	
Messschritt	1000 µm
Erster Referenzpuls bei Messposition	335,0 mm
Relative Luftfeuchtigkeit	max. 50 %

Measurement parameters	
Measurement step	1000 µm
First reference pulse at measured position	335,0 mm
Relative humidity	max. 50 %

Dieser Maßstab wurde unter den strengen HEIDENHAIN-Qualitätsnormen hergestellt und geprüft. Die Positionsabweichung liegt bei einer Bezugstemperatur von 20 °C innerhalb der Genauigkeitsklasse ± 1,0 µm.

This scale has been manufactured and inspected in accordance with the stringent quality standards of HEIDENHAIN. The position error at a reference temperature of 20 °C lies within the accuracy grade ± 1,0 µm.

Kalbriernormale	Kalbrierzeichen
Jod-stabilisierter He-Ne Laser	40151 PTB 11
Wasser-Tripelpunktzelle	61 PTB 10
Gallium-Schmelzpunktzelle	62 PTB 10
Barometer	A6590 D-K-15092-01-00 2012-12
Luftfeuchtemessgerät	0230 DKD-K-30601 2012-11

Calibration standards	Calibration references
Iodine-stabilized He-Ne Laser	40151 PTB 11
Water triple point cell	61 PTB 10
Gallium melting point cell	62 PTB 10
Pressure gauge	A6590 D-K-15092-01-00 2012-12
Hygrometer	0230 DKD-K-30601 2012-11

DR. JOHANNES HEIDENHAIN GmbH · 83301 Traunreut, Germany · www.heidenhain.de · Telefon: +49 8669 31-0 · Fax: +49 8669 5061

28.01.2014
Prüfer/Inspected by K. Sommerauer

Mechanical design types and mounting

Linear scales

Exposed linear encoders are made up of two separate components: the scanning head and linear scale or scale tape, which are brought together solely over the machine guideway. For this reason, the machine must be designed from the very beginning to meet the following requirements:

- The machine guideway must be designed such that the **scanning gap tolerances** are complied with at the location where the encoder is installed (see *Specifications*)
- The mounting surface of the scale must meet the **flatness** requirements
- To facilitate adjustment of the scanning head to the scale, the scanning head should be fastened with a **mounting bracket**

Scale versions

HEIDENHAIN provides the appropriate scale version for the given application and accuracy requirements.

LIP 201 LIP 6001 LIC 4003

The graduation carriers are fastened directly to the mounting surface with clamps. A holder is used to define the thermal fixed point.

Accessories for the LIC 41x3 and LIP 60x1:

Fixing clamps	ID 1176458-01
Holder for thermal fixed point	ID 1176475-01
Spacer shims	ID 1176441-01
Adhesive*	ID 1180444-01
Double-cartridge gun	ID 1180450-01
Dispensing nozzles and mixing tubes	ID 1176444-01

LIP 6001 LIF 401 LIDA 403 LIC 4003

The graduation carriers are adhesively bonded directly to the mounting surface with PRECIMET adhesive mounting film, with even pressure applied by means of a roller. A thermal fixed point can be established at a location with epoxy adhesive.

Accessory

Roller	ID 276885-01
--------	--------------

* Caution: no transport by air (dangerous goods)
Trade name: 3M Scotch-Weld
Epoxy Adhesive DP-460 EG

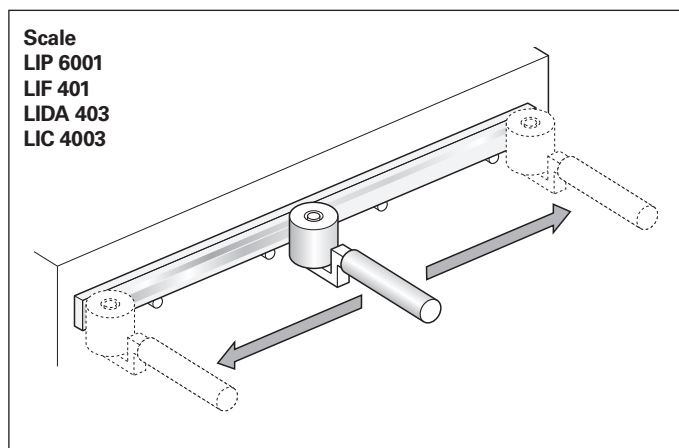
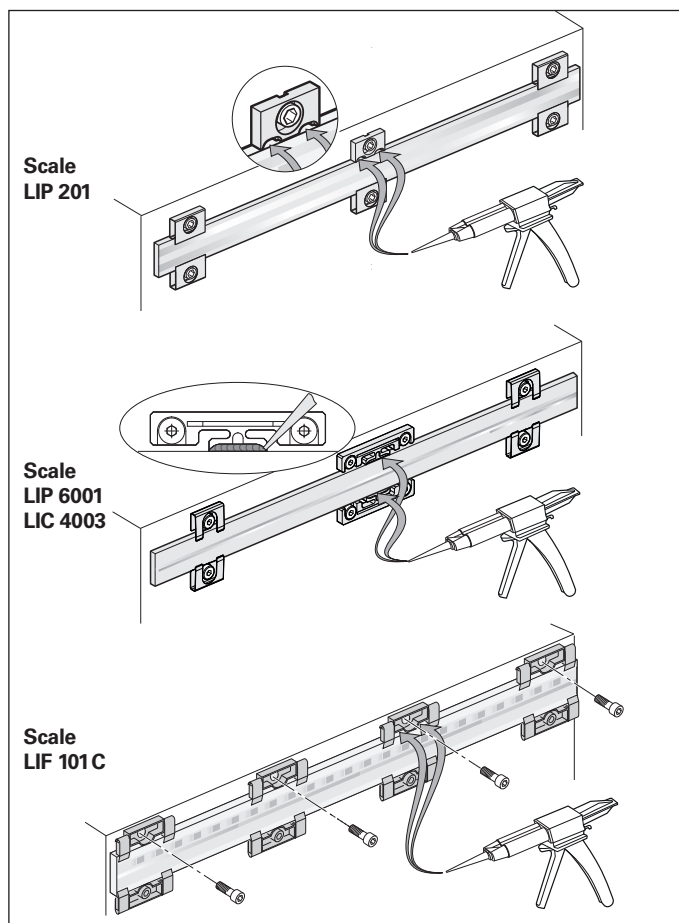

LIC 41x5
LIDA 4x5

Linear encoders of the LIC 41x5 and LIDA 4x5 series are specially designed for long measuring lengths. They are mounted with scale carrier sections screwed onto the mounting surface or adhesively bonded with PRECIMET adhesive mounting film. The single-piece steel scale tape is then pulled through the carrier sections, **tensioned as specified**, and **secured at its ends** to the machine base. The LIC 41x5 and LIDA 4x5 encoders thereby exhibit the same thermal behavior as that of the mounting surface.

LIC 21x7
LIC 31x7
LIC 41x7
LIDA 2x7
LIDA 4x7

The encoders of these series are also designed for long measuring lengths. The scale carrier sections are adhesively bonded to the mounting surface with PRECIMET adhesive mounting film; the single-piece scale tape is pulled through, and **the midpoint is secured** to the machine base. This mounting method allows the scale tape to expand freely at both ends and ensures a defined thermal behavior.

Accessory for LIC 41x7, LIDA 4x7
Mounting aid ID 373990-01

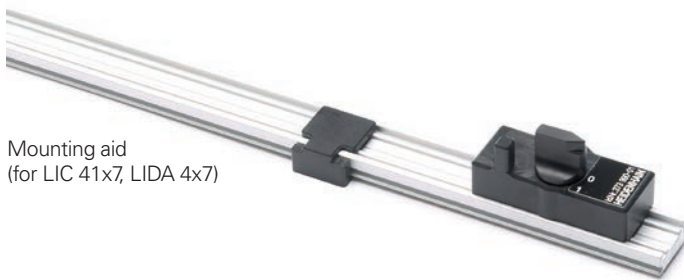

Mounting aid
(for LIC 41x7, LIDA 4x7)

LIC 21x9
LIC 31x1
LIC 41x9
LIDA 2x9
LIDA 4x9

The steel scale tape of the graduation is adhesively bonded directly to the mounting surface with PRECIMET adhesive mounting film, with pressure applied evenly with a roller. A ridge or aligning rail with a height of 0.3 mm must be provided for the horizontal alignment of the scale tape.

Accessories for versions with PRECIMET
Roller ID 276885-01
Mounting aid, LIDA 2x9 ID 1070307-01
Mounting aid, LIC 21x9 ID 1070853-01

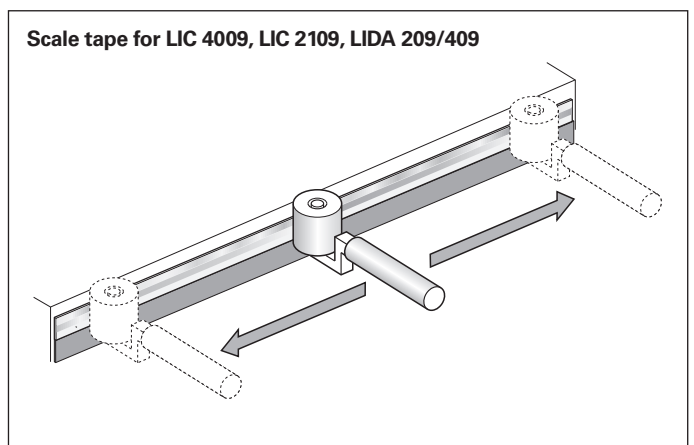
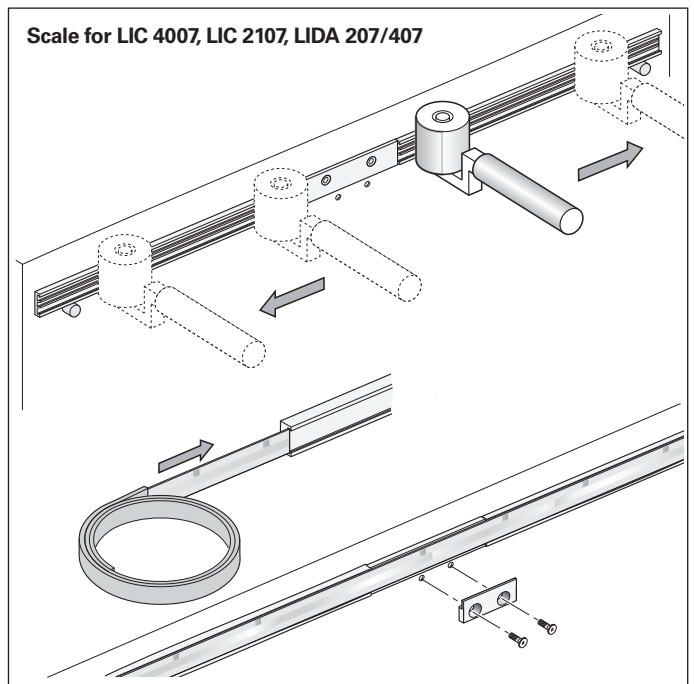
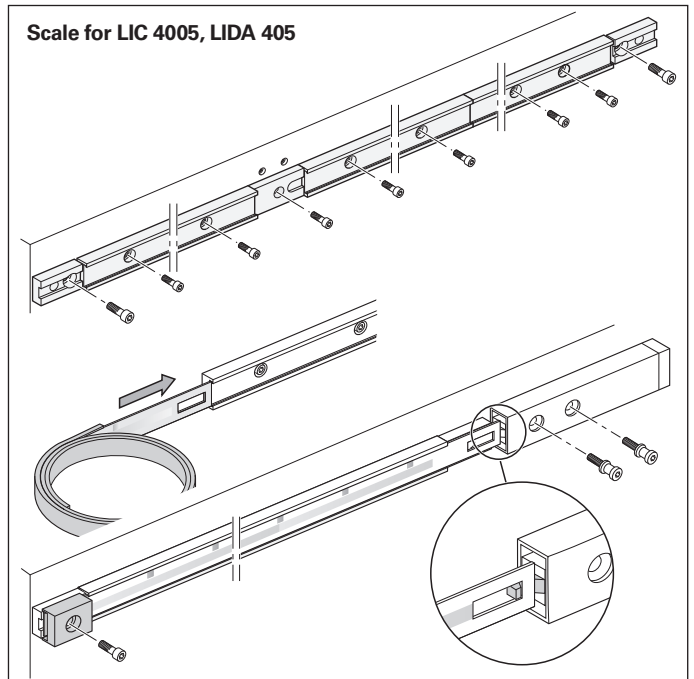

Mechanical design types and mounting

Scanning heads

Because exposed linear encoders are assembled on the machine, they must be precisely adjusted after mounting. This adjustment determines the final accuracy of the encoder. It is therefore advisable to design the machine such that this adjustment is as easy and practical as possible, while also ensuring the greatest possible degree of mounting stability.

Mounting the LIP 2x1

The LIP 2x can be fastened from the side as well as from above. The housing cover has a raised contact surface for the thermal connection to ensure optimal heat dissipation. The contact surface is compressed against the mounting element during mounting.

Mounting the LIP 60x1

The LIP 60x can be fastened from the side as well as from above. When mounted from above, it is additionally possible to define a fixed center of rotation by inserting an alignment pin with $\varnothing 2$ mm or $\varnothing 3$ mm. This facilitates the alignment of the scanning head parallel to the scale. The alignment pin can be removed when mounting is completed.

Mounting the LIF

This scanning head features a centering collar with which the scanning head can be rotated in the location hole of the angle bracket and thereby aligned parallel to the scale.

Mounting the LIC/LIDA

There are three options for mounting the scanning head (see Dimensions). A spacer shim makes it quite easy to set the gap between the scanning head and the scale or scale tape. It is helpful to fasten the scanning head from behind with a mounting bracket. The scanning head can be very precisely adjusted through a hole in the mounting bracket with the aid of a tool.

Adjustment

The gap between the scale and scanning head is easily adjusted with the aid of a spacer shim.

The signals from the LIC, LIP 6000, and LIP 200 can be quickly and easily adjusted with the aid of the PWM 20/21 adjustment and testing package. For all other exposed linear encoders, the incremental and reference mark signals are adjusted through a slight rotation of the scanning head (for the LIDA 400, it is possible with the aid of a tool).

HEIDENHAIN offers the appropriate measuring and testing devices as adjustment aids (see *Testing equipment and diagnostics*).

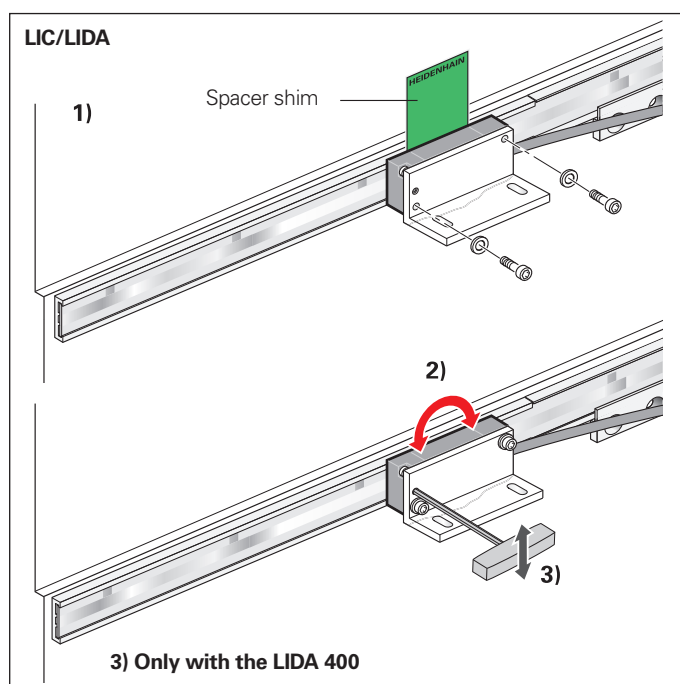
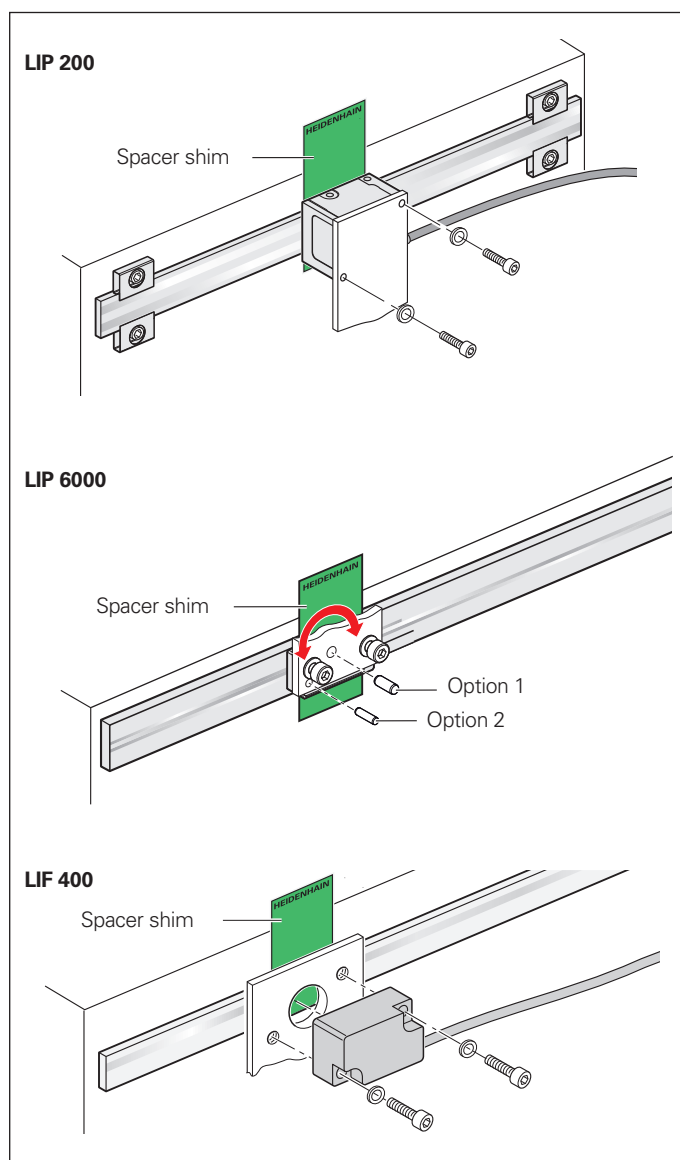

Signal-quality indicator

The LIDA, LIF, and LIP 6071 linear encoders feature an integrated signal-quality indicator with a multicolor LED, permitting fast and easy signal-quality checks during operation.

This feature provides a number of benefits:

- Scanning-signal quality visualization through a multicolor LED
- Continuous monitoring of incremental signals over the entire measuring length
- Indication of reference-mark signal behavior
- Quick signal-quality checks in the field without additional aids

The built-in signal-quality indicator permits both a reliable assessment of the incremental signals and inspection of the reference mark signal. The quality of the **incremental signals** is indicated by a range of colors permitting quite detailed signal-quality differentiation. The tolerance conformity of the **reference mark signal** is shown by means of a pass/fail indicator.



LIDA: signal-quality indicator in the scanning head



LIF, LIP 6071: signal-quality indicator in the interface electronics

LED indicator for incremental signals

LED color	Quality of the scanning signals
●	Optimal
●	Good
●	Acceptable
●	Unsatisfactory

LED indicator for reference-mark-signal

(operating check)

When the reference mark is traversed, the LED briefly lights up in red or blue:

- Out of tolerance
- Within tolerance

LED indicator for control margin

A flashing LED that turns dark every 2.5 seconds indicates that the control margin of the scanning ASIC is almost exhausted. In this case, you should clean the measuring standard and the scanning window of the scanning head in compliance with the relevant information in the mounting instructions. The encoder may also need to be checked for correct mounting.

General mechanical information

Temperature range

The **operating temperature range** states the limits of ambient temperature within which the specifications of the linear encoder are complied with. The **storage temperature range** of -20 °C to $+70\text{ °C}$ applies when the unit remains in its packaging.

Thermal characteristics

The thermal behavior of the linear encoder is an essential criterion for the working accuracy of the machine. As a general rule, the thermal behavior of the linear encoder should match that of the workpiece or measured object. During temperature changes, the linear encoder should expand or contract in a defined, reproducible manner.

The graduation carriers of HEIDENHAIN linear encoders (see *Specifications*) have differing coefficients of thermal expansion. This makes it possible to select the linear encoder with the thermal behavior best suited to the application.

Parts subject to wear

Encoders from HEIDENHAIN are designed for a long service life. Preventive maintenance is not required. However, they do contain components that are subject to wear, depending on the application and how they are deployed. This especially applies to cables that are subjected to frequent flexing.

Other parts subject to wear are the bearings in encoders with integral bearing, the radial shaft seal rings in rotary encoders and angle encoders, and the sealing lips on sealed linear encoders.

Protection (EN 60529)

The scanning heads of exposed linear encoders feature the following degrees of protection:

Scanning head	Protection
LIC	IP67
LIDA	IP40
LIF	IP50
LIP 200	IP40
LIP 300 LIP 6000	IP50
PP	IP50

The scales have no special protection. If the scales are exposed to contamination, protective measures must be taken.

Acceleration

Linear encoders are subject to various types of acceleration during operation and mounting.

- The indicated maximum values for **vibration** apply to frequencies of 55 Hz to 2000 Hz (**EN 60068-2-6**). If, depending on the application and the mounting scenario, the permissible acceleration values are exceeded (e.g., in the case of resonances), then the encoder can become damaged. **Comprehensive testing of the entire system is therefore required**
- The maximum permissible acceleration values (semi-sinusoidal shock) for **shock and impact loads** are valid for 11 ms or 6 ms (**EN 60068-2-27**). Under no circumstances should a hammer or similar implement be used to adjust or position the encoder

System tests

Encoders from HEIDENHAIN are usually integrated as components into complete systems. Such applications require **comprehensive testing of the entire system**, irrespective of the encoder's specifications.

The specifications provided in this brochure apply only to the encoder and not to the entire system. Any operation of the encoder outside of the specified range or outside of its proper and intended use is at the user's own risk.

In safety-related systems, the encoder's position value must be tested by the higher-level system after switch-on.

Assembly

The steps and dimensions that must be complied with during mounting are specified solely in the mounting instructions supplied with the device. All mounting-related information in this brochure is therefore provisional and non-binding, and will not become the subject matter of a contract.

Functional safety

With the absolute linear encoders of the LIC 4100 series, HEIDENHAIN offers an ideal solution for position acquisition on linear axes in safety-related applications. In conjunction with a safe control, the encoders can be used as single-encoder systems in applications with control category SIL 2 (as per EN 61508) or performance level “d” (as per EN ISO 13849).

The reliable transmission of the position is based on two independently generated absolute position values and on error bits provided to the safe control. The functions of the encoder can be used for numerous safety functions of the complete system as per EN 61800-5-2.

The LIC 4100 linear encoder can provide a safe, absolute position value at any time—including immediately after switch-on. Purely serial data transfer takes place via the bidirectional EnDat 2.2 interface.

In addition to the data interface, the mechanical connection of the encoder to the drive is also safety-relevant. In table D8 of the standard for electrical drive systems, EN 61800-5-2, the loosening of the mechanical connection between the encoder and the motor is listed as a fault that requires consideration. Since it cannot be guaranteed that the control will detect such errors, fault exclusion for the loosening of the mechanical connection is required in many cases.

Unless otherwise specified, HEIDENHAIN encoders are designed for a service life of 20 years (in accordance with ISO 13849).

Fault exclusion for the loosening of the mechanical connection

The machine manufacturer is responsible for the dimensioning of mechanical connections in a drive system. During the mechanical design phase, the OEM will ideally consider the conditions within the application. Verifying a safe connection, however, is both cost- and time-intensive. That’s why HEIDENHAIN has developed a type-examined mechanical fault exclusion for the LIC 4100 series.

Mounting and operating conditions

This fault exclusion has been qualified for a wide range of encoder applications and is ensured for the operating conditions listed below.

Mechanical connection	Fastening	Safe position for the mechanical coupling	Confined parameters ³⁾
Scale	Screw connection ^{1) 2)}	±0.0 mm	See specifications: <ul style="list-style-type: none"> • Vibration • Shock See mounting information: <ul style="list-style-type: none"> • Usable materials • Mounting conditions
Scanning head	Mounting configurations I and II: Screw connection: ²⁾ M2x25 ISO 4762 8.8 screws		
	Mounting configuration III: Screw connection: ²⁾ M2x16 ISO 4762 8.8 screws		

¹⁾ A material bonding anti-rotation lock is to be used for the screw connections of the scale (mounting/servicing)

²⁾ Friction class B as per VDI 2230

³⁾ When compared with an LIC 4100 without functional safety

Material

The material used for the mounting surfaces of the scanning head and measuring standard must comply with the specifications provided in the table.

Mounting temperature

All information on screw connections is based on a mounting temperature of 15 °C to 35 °C.

Mounting the scanning head

M2 screws as per ISO 4762 8.8 are to be used for the mechanical fault exclusion (included in delivery). A PWM20/21 and the mounting wizard of the ATS software are then used to check and optimize the mounting.

Mounting the scale tape

The steel scale tape of the graduation is adhesively bonded directly to the mounting surface with PRECIMET adhesive mounting film, with pressure applied evenly with a roller. The scale tape is additionally secured by a screw (punched hole in scale tape). The mounting aid (included in delivery) facilitates the symmetrical alignment of the screw to the punched hole.

Note:

The scanning head may be operated only within the permissible mounting tolerances and measuring length of the measuring standard.

Included in delivery:

Scanning head

- Fastener kit ID 1233536-01
(two M2x16 screws)
- Fastener kit ID 1233536-02
(two M2x25 screws)
- Spacer shim ID 578983-06

Scale

- One screw ID 1233558-01
- Mounting aid ID 1244387-02

Accessories:

- Mounting wizard in ATS software
- Roller ID 276885-01

	Angle bracket for scanning head		Mounting surface for measuring standard
Material	Steel	Aluminum	Steel, aluminum
Tensile strength R_m	$\geq 600 \text{ N/mm}^2$	$\geq 220 \text{ N/mm}^2$	Not applicable
Shear strength τ_B	$\geq 390 \text{ N/mm}^2$	$\geq 130 \text{ N/mm}^2$	Not applicable
Elastic modulus E	$\geq 200\,000 \text{ N/mm}^2$ to $215\,000 \text{ N/mm}^2$	$\geq 70\,000 \text{ N/mm}^2$ to $75\,000 \text{ N/mm}^2$	Not applicable
Coefficient of thermal expansion α_{them}	$10 \cdot 10^{-6} \text{ K}^{-1}$ to $17 \cdot 10^{-6} \text{ K}^{-1}$	$25 \cdot 10^{-6} \text{ K}^{-1}$	$10 \cdot 10^{-6} \text{ K}^{-1}$ to $25 \cdot 10^{-6} \text{ K}^{-1}$

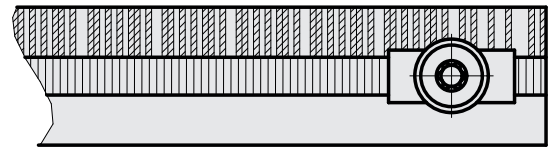

LIC 4113, LIC 4193

Absolute linear encoders for measuring lengths of up to 3 m

- Measuring steps of down to 1 nm
- Glass or glass ceramic measuring standard
- Measuring standard secured with adhesive film or fixing clamps
- Consisting of a linear scale and scanning head (with straight or angled cable outlet)
- Version available for use in a high vacuum (see separate Product Information document)

Scale, clamped

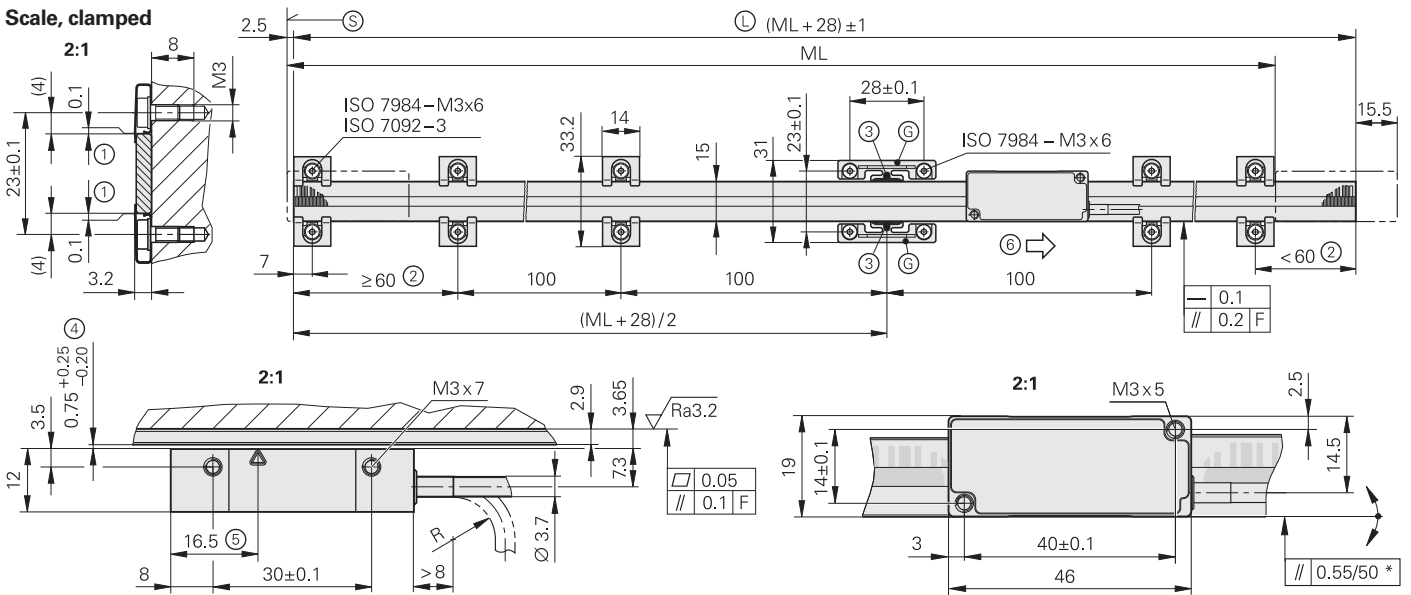

Scale, adhesively bonded

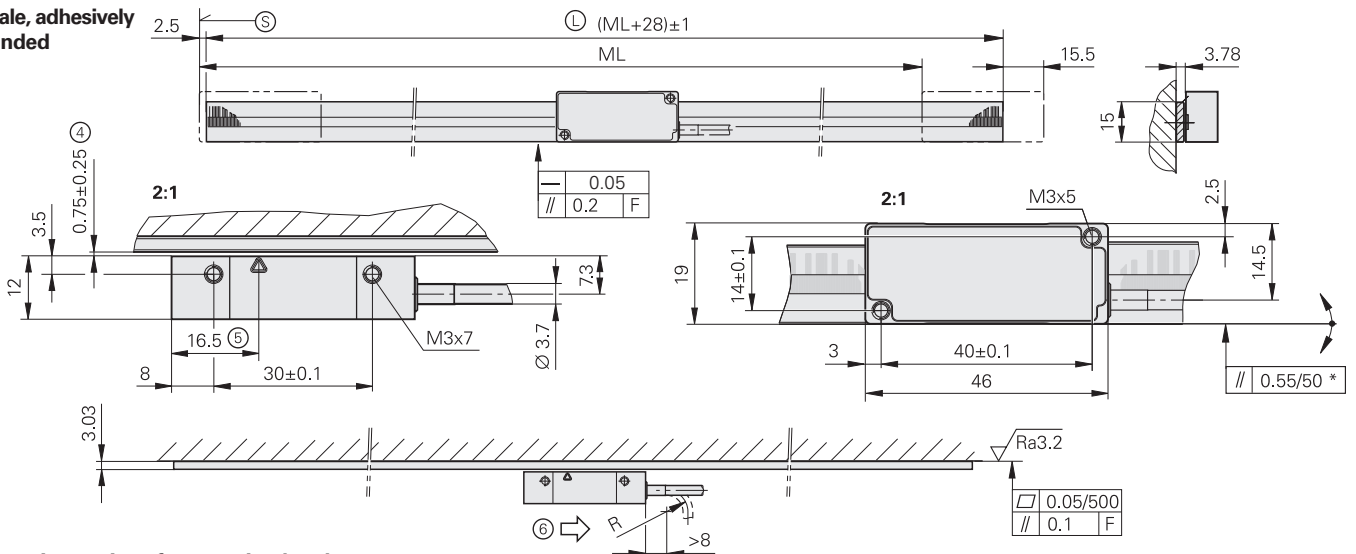

Mounting options for scanning head

(shown without fixing clamps)

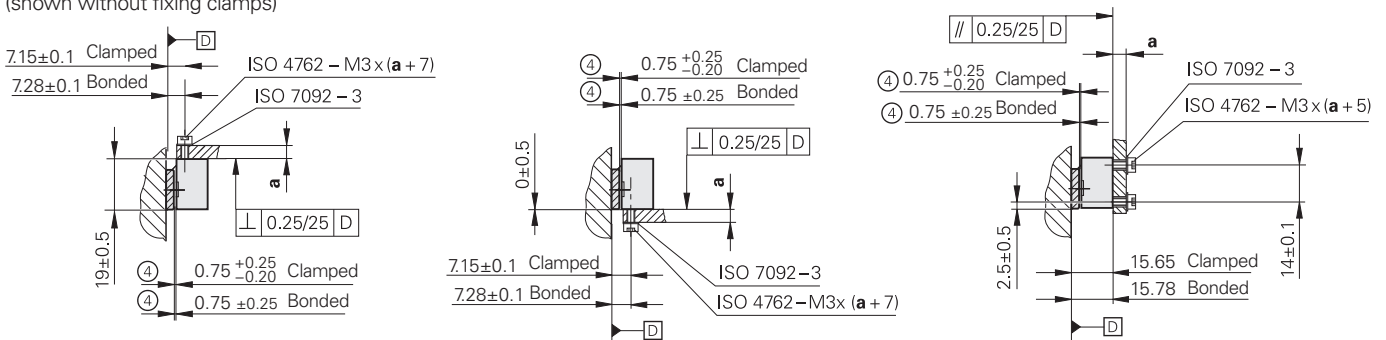

F = Machine guideway

* = Mounting error plus dynamic guideway error

⊙ = Beginning of measuring length (ML)

⊙ = Absolute track start value: 100±1 mm

⊙ = Scale length

⊙ = Fixed-point element for defining the thermal fixed point

1 = Gap is adjusted with a spacer shim during mounting

2 = Depending on the measuring length (ML), use an additional pair of fixing clamps

3 = Adhesive

4 = Mounting clearance between scanning head and linear scale

5 = Optical centerline

6 = Direction of motion of the scanning unit for ascending position values

mm



Tolerancing ISO 8015

ISO 2768 - m H

< 6 mm: ±0.2 mm



Linear scale	LIC 4003
Measuring standard Coefficient of linear expansion*	METALLUR grating on glass or glass ceramic $\alpha_{\text{therm}} \approx 8 \cdot 10^{-6} \text{ K}^{-1}$ (glass) $\alpha_{\text{therm}} = (0 \pm 0.5) \cdot 10^{-6} \text{ K}^{-1}$ (Robax glass ceramic)
Accuracy grade*	$\pm 1 \mu\text{m}$ (only for Robax glass ceramic), $\pm 3 \mu\text{m}$, $\pm 5 \mu\text{m}$
Baseline error	$\leq \pm 0.275 \mu\text{m}/10 \text{ mm}$
Measuring length (ML)* in mm	240 340 440 640 840 1040 1240 1440 1640 1840 2040 2240 2440 2640 2840 3040 (Robax glass ceramic only up to ML of 1640)
Mass	3 g + 0.11 g/mm of measuring length

Scanning head	LIC 411	LIC 419F	LIC 419M	LIC 419P	LIC 419Y	
Interface	EnDat 2.2	Fanuc Serial Interface αi	Mitsubishi high speed interface	Panasonic Serial Interface	Yaskawa Serial Interface	
Ordering designation*	EnDat22	Fanuc05	Mit03-4	Mit03-2	Pana02	YEC07
Measuring step*	10 nm, 5 nm, 1 nm ¹⁾					
Bit width	36 bits	–				
Calculation time t_{cal} Clock frequency	$\leq 5 \mu\text{s}$ $\leq 16 \text{ MHz}$	–				
Traversing speed ²⁾	$\leq 600 \text{ m/min}$					
Interpolation error	$\pm 20 \text{ nm}$					
Electrical connection*	Cable (1 m or 3 m) with 8-pin M12 coupling (male) or 15-pin D-sub connector (male)					
Cable length (with HEIDENHAIN cable)	$\leq 100 \text{ m}$	$\leq 50 \text{ m}$	$\leq 30 \text{ m}$	$\leq 50 \text{ m}$		
Supply voltage	DC 3.6V to 14 V					
Power consumption ²⁾ (max.)	At 3.6 V: $\leq 700 \text{ mW}$ At 14 V: $\leq 800 \text{ mW}$	At 3.6 V: $\leq 850 \text{ mW}$ At 14 V: $\leq 950 \text{ mW}$				
Current consumption (typical)	At 5 V: 75 mA (without load)	At 5 V: 95 mA (without load)				
Vibration 55 Hz to 2000 Hz Shock 6 ms	$\leq 500 \text{ m/s}^2$ (EN 60068-2-6) $\leq 1000 \text{ m/s}^2$ (EN 60068-2-27)					
Operating temperature	$-10 \text{ }^\circ\text{C}$ to $70 \text{ }^\circ\text{C}$					
Mass	Scanning head	$\leq 18 \text{ g}$ (without cable)				
	Cable	20 g/m				
	Connecting element	M12 coupling: 15 g; D-sub connector: 32 g				

* Please select when ordering

¹⁾ Mitsubishi: measuring length $\leq 2040 \text{ mm}$

Yaskawa: measuring length $\leq 1840 \text{ mm}$

²⁾ See *General electrical information* in the *Interfaces of HEIDENHAIN Encoders* brochure

Robax is a registered trademark of Schott-Glaswerke, Mainz, Germany



Scale	LIC 4005
Measuring standard Coefficient of linear expansion	Steel scale tape with absolute and incremental METALLUR track Depends on the mounting surface
Accuracy grade	±5 µm
Baseline error	≤ ±0.750 µm/50 mm (typical)
Measuring length (ML)* in mm	140 240 340 440 540 640 740 840 940 1040 1140 1240 1340 1440 1540 1640 1740 1840 1940 2040
	Greater measuring lengths (up to 28440 mm) with a single-section scale tape and individual scale carrier sections
Mass Scale tape Parts kit Scale tape carrier	31 g/m 80 g + n ¹⁾ · 27 g 187 g/m

Scanning head	LIC 411	LIC 419F	LIC 419M	LIC 419P	LIC 419Y	
Interface	EnDat 2.2	Fanuc Serial Interface α i	Mitsubishi high speed interface	Panasonic Serial Interface	Yaskawa Serial Interface	
Ordering designation*	EnDat22	Fanuc05	Mit03-4	Mit03-2	Pana02	YEC07
Measuring step* ²⁾	10 nm, 5 nm, 1 nm					
Bit width	36 bits	–				
Calculation time t_{cal} Clock frequency	≤ 5 µs ≤ 16 MHz	–				
Traversing speed ³⁾	≤ 600 m/min					
Interpolation error	±20 nm					
Electrical connection*	Cable (1 m or 3 m) with 8-pin M12 coupling (male) or 15-pin D-sub connector (male)					
Cable length (with HEIDENHAIN cable)	≤ 100 m	≤ 50 m	≤ 30 m	≤ 50 m		
Supply voltage	DC 3.6 V to 14 V					
Power consumption ³⁾ (max.)	At 3.6 V: ≤ 700 mW At 14 V: ≤ 800 mW	At 3.6 V: ≤ 850 mW At 14 V: ≤ 950 mW				
Current consumption (typical)	At 5 V: 75 mA (without load)	At 5 V: 95 mA (without load)				
Vibration 55 Hz to 2000 Hz Shock 6 ms	≤ 500 m/s ² (EN 60068-2-6) ≤ 1000 m/s ² (EN 60068-2-27)					
Operating temperature	–10 °C to 70 °C					
Mass Scanning head Cable Connecting element	≤ 18 g (without cable) 20 g/m M12 coupling: 15 g; D-sub connector: 32 g					

* Please select when ordering

¹⁾ n = 1 for ML 3140 mm to 5040 mm; n = 2 for ML 5140 mm to 7040 mm; etc.*

²⁾ *Mitsubishi*: 1 nm: measuring length ≤ 2040 mm; 5 nm: measuring length ≤ 10040 mm; 10 nm: measuring length ≤ 20040 mm

Yaskawa: 1 nm: measuring length ≤ 1840 mm; 5 nm: measuring length ≤ 9040 mm; 10 nm: measuring length ≤ 18040 mm

³⁾ See *General electrical information* in the *Interfaces of HEIDENHAIN Encoders* brochure

LIC 4117, LIC 4197

Absolute linear encoders for measuring lengths of up to 6 m

- For measuring steps of down to 1 nm
- Steel scale tape pulled through aluminum extrusions and fastened at center
- Consisting of a linear scale and scanning head (with straight or angled cable outlet)

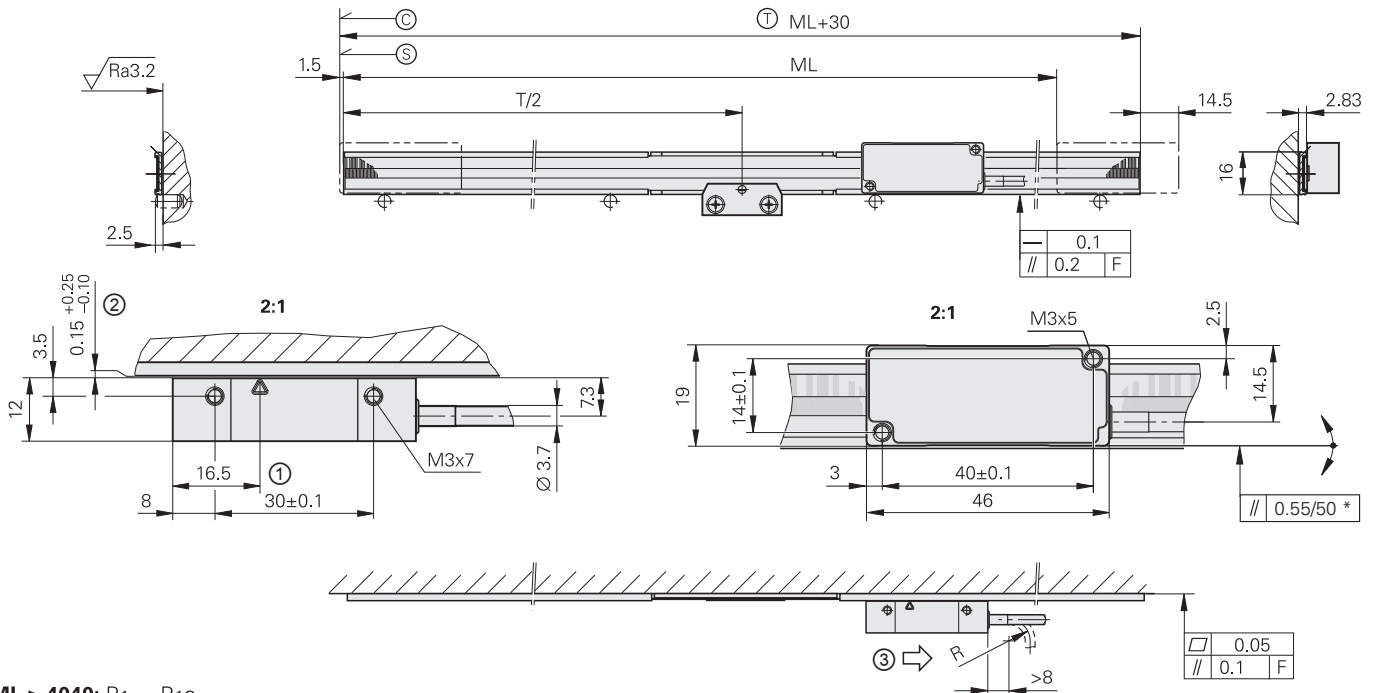

ML > 4040: P₁ ... P₁₃
 ML ≤ 4040: (P₁ ... P₄)

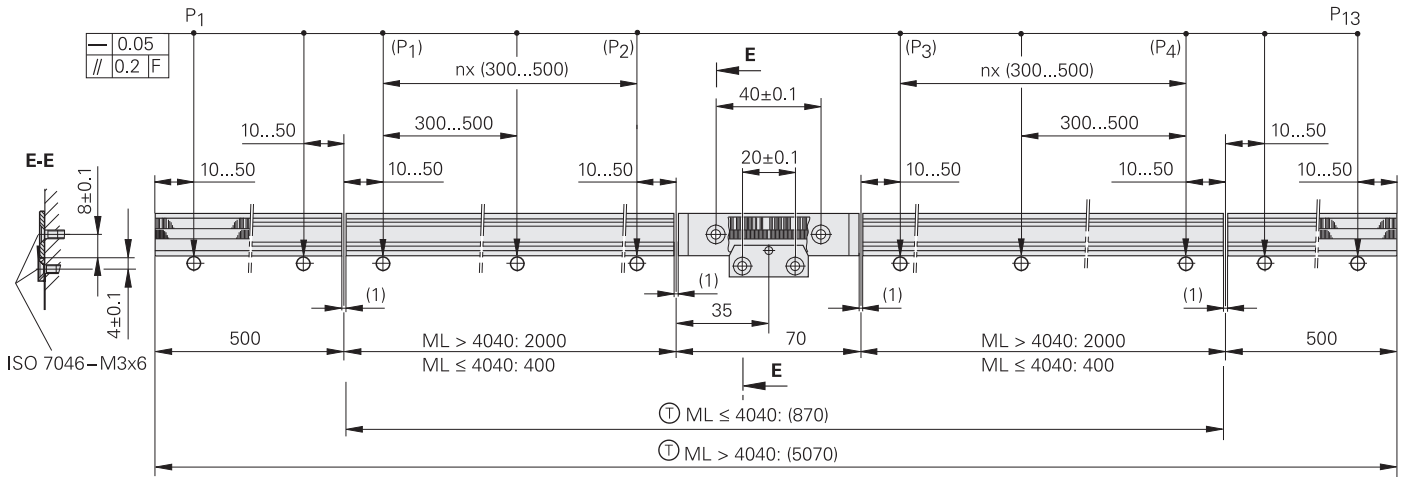

Mounting options for scanning head

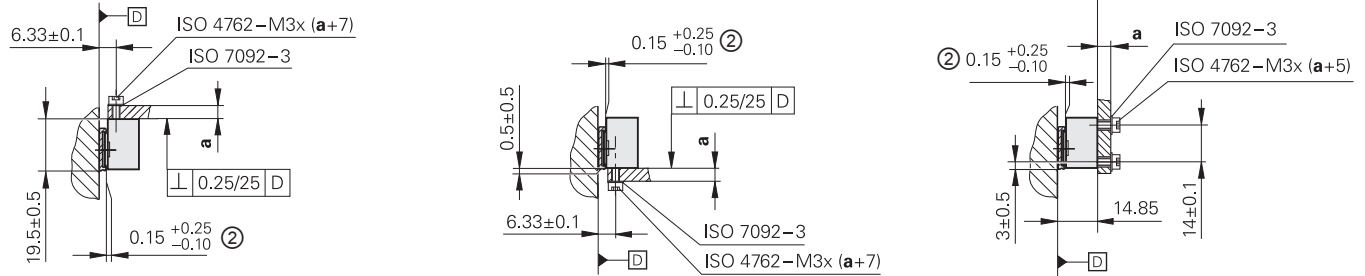

mm
 Tolerancing ISO 8015
 ISO 2768 - m H
 < 6 mm: ±0.2 mm

- F = Machine guideway
- P = Measuring points for alignment
- * = Mounting error plus dynamic guideway error
- © = Absolute track start value: 100 mm
- ⊙ = Beginning of measuring length (ML)
- Ⓣ = Carrier length
- 1 = Optical centerline
- 2 = Mounting clearance between scanning head and extrusion
- 3 = Direction of motion of the scanning unit for ascending position values



Scale	LIC 4007
Measuring standard Coefficient of linear expansion	Steel scale tape with absolute and incremental METALLUR track $\alpha_{\text{therm}} \approx 10 \cdot 10^{-6} \text{ K}^{-1}$
Accuracy grade*	$\pm 3 \mu\text{m}$ (up to ML 1040), $\pm 5 \mu\text{m}$ (for ML 1240 or greater), $\pm 15 \mu\text{m}^{1)}$
Baseline error	$\leq \pm 0.750 \mu\text{m}/50 \text{ mm}$ (typical)
Measuring length (ML)* in mm	240 440 640 840 1040 1240 1440 1640 1840 2040 2240 2440 2640 2840 3040 3240 3440 3640 3840 4040 4240 4440 4640 4840 5040 5240 5440 5640 5840 6040
Mass	Scale tape 31 g/m Parts kit 20 g Scale tape carrier 68 g/m

Scanning head	LIC 411	LIC 419F	LIC 419M	LIC 419P	LIC 419Y	
Interface	EnDat 2.2	Fanuc Serial Interface α i	Mitsubishi high speed interface	Panasonic Serial Interface	Yaskawa Serial Interface	
Ordering designation*	EnDat22	Fanuc05	Mit03-4	Mit03-2	Pana02	YEC07
Measuring step*	10 nm, 5 nm, 1 nm ²⁾					
Bit width	36 bits	–				
Calculation time t_{cal} Clock frequency	$\leq 5 \mu\text{s}$ $\leq 16 \text{ MHz}$	–				
Traversing speed³⁾	$\leq 600 \text{ m/min}$					
Interpolation error	$\pm 20 \text{ nm}$					
Electrical connection*	Cable (1 m or 3 m) with 8-pin M12 coupling (male) or 15-pin D-sub connector (male)					
Cable length (with HEIDENHAIN cable)	$\leq 100 \text{ m}$	$\leq 50 \text{ m}$	$\leq 30 \text{ m}$	$\leq 50 \text{ m}$		
Supply voltage	DC 3.6 V to 14 V					
Power consumption ³⁾ (max.)	At 3.6 V: $\leq 700 \text{ mW}$ At 14 V: $\leq 800 \text{ mW}$	At 3.6 V: $\leq 850 \text{ mW}$ At 14 V: $\leq 950 \text{ mW}$				
Current consumption (typical)	At 5 V: 75 mA (without load)	At 5 V: 95 mA (without load)				
Vibration 55 Hz to 2000 Hz Shock 6 ms	$\leq 500 \text{ m/s}^2$ (EN 60068-2-6) $\leq 1000 \text{ m/s}^2$ (EN 60068-2-27)					
Operating temperature	$-10 \text{ }^\circ\text{C}$ to $70 \text{ }^\circ\text{C}$					
Mass	Scanning head Cable Connecting element	$\leq 18 \text{ g}$ (without cable) 20 g/m M12 coupling: 15 g; D-sub connector: 32 g				

* Please select when ordering

¹⁾ $\pm 5 \mu\text{m}$ after linear length-error compensation in the subsequent electronics

²⁾ Mitsubishi: measuring length $\leq 2040 \text{ mm}$

Yaskawa: measuring length $\leq 1840 \text{ mm}$

³⁾ See General electrical information in the Interfaces of HEIDENHAIN Encoders brochure

LIC 4119, LIC 4199

Absolute linear encoders for measuring lengths of up to 1 m

- For measuring steps of down to 1 nm
- Steel scale tape adhesively bonded to mounting surface
- Consisting of a linear scale and scanning head (with straight or angled cable outlet)

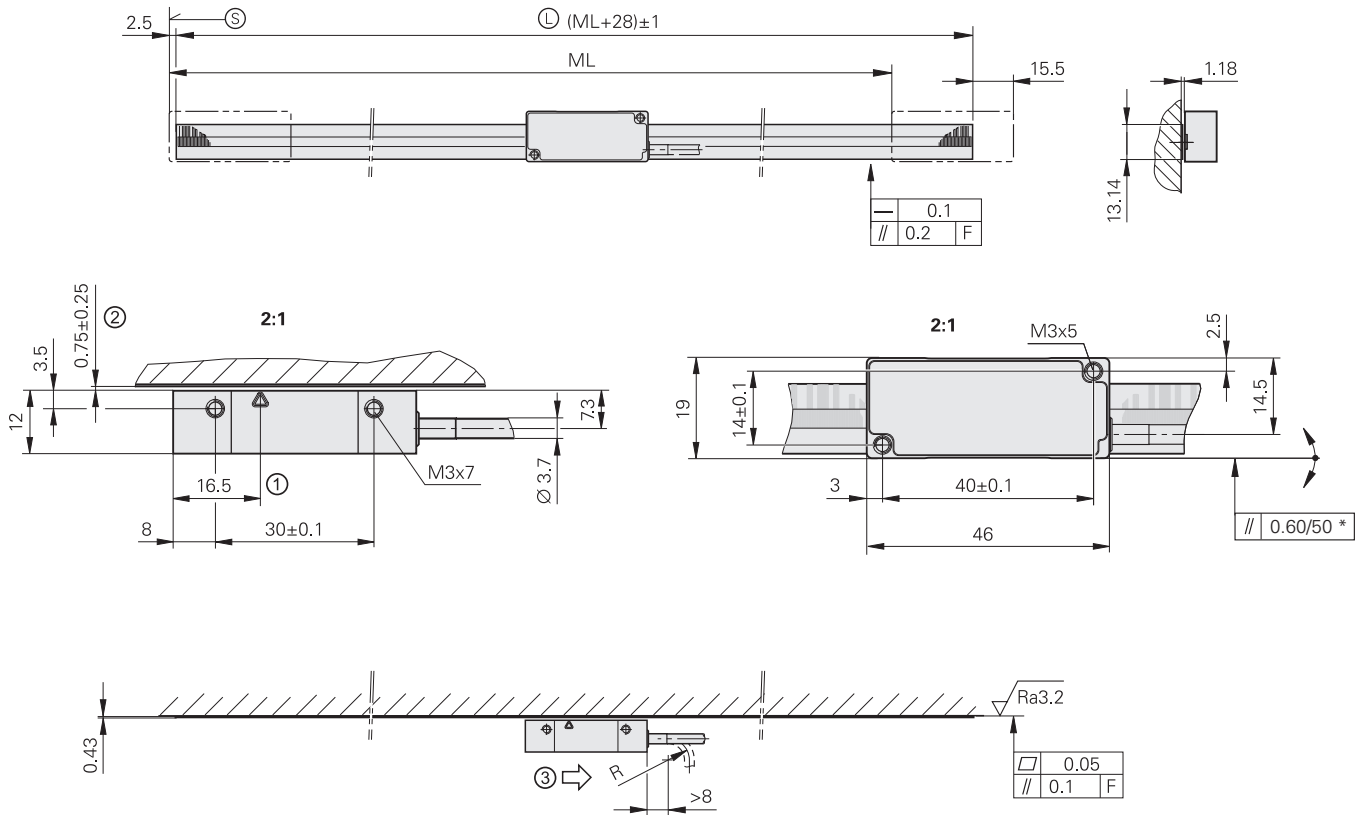

Mounting options for scanning head

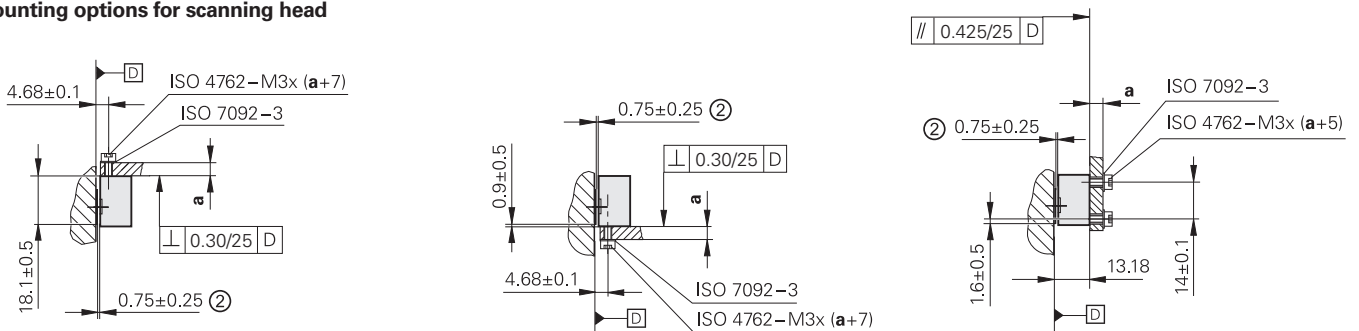

mm

 Tolerancing ISO 8015
 ISO 2768 - m H
 < 6 mm: ±0.2 mm

- F = Machine guideway
- * = Mounting error plus dynamic guideway error
- © = Absolute track start value: 100 mm
- ⊙ = Beginning of measuring length (ML)
- ⊕ = Scale tape length
- 1 = Optical centerline
- 2 = Mounting clearance between scanning head and linear scale
- 3 = Direction of motion of the scanning unit for ascending position values



Scale	LIC 4009
Measuring standard Coefficient of linear expansion	Steel scale tape with absolute and incremental METALLUR track $\alpha_{\text{therm}} \approx 10 \cdot 10^{-6} \text{ K}^{-1}$
Accuracy grade*	$\pm 3 \mu\text{m}, \pm 15 \mu\text{m}^{1)}$
Baseline error	$\leq \pm 0.750 \mu\text{m}/50 \text{ mm}$ (typical)
Measuring length (ML)* in mm	70 120 170 220 270 320 370 420 520 620 720 820 920 1020
Mass	31 g/m

Scanning head	LIC 411	LIC 419F	LIC 419M	LIC 419P	LIC 419Y	
Interface	EnDat 2.2	Fanuc Serial Interface αi	Mitsubishi high speed interface	Panasonic Serial Interface	Yaskawa Serial Interface	
Ordering designation*	EnDat22	Fanuc05	Mit03-4	Mit03-2	Pana02	YEC07
Measuring step*	10 nm, 5 nm, 1 nm ²⁾					
Bit width	36 bits	–				
Calculation time t_{cal} Clock frequency	$\leq 5 \mu\text{s}$ $\leq 16 \text{ MHz}$	–				
Traversing speed ³⁾	$\leq 600 \text{ m/min}$					
Interpolation error	$\pm 20 \text{ nm}$					
Electrical connection*	Cable (1 m or 3 m) with 8-pin M12 coupling (male) or 15-pin D-sub connector (male)					
Cable length (with HEIDENHAIN cable)	$\leq 100 \text{ m}^{4)}$	$\leq 50 \text{ m}$	$\leq 30 \text{ m}$	$\leq 50 \text{ m}$		
Supply voltage	DC 3.6 V to 14 V					
Power consumption ³⁾ (max.)	At 3.6 V: $\leq 700 \text{ mW}$ At 14 V: $\leq 800 \text{ mW}$	At 3.6 V: $\leq 850 \text{ mW}$ At 14 V: $\leq 950 \text{ mW}$				
Current consumption (typical)	At 5 V: 75 mA (without load)	At 5 V: 95 mA (without load)				
Vibration 55 Hz to 2000 Hz Shock 6 ms	$\leq 500 \text{ m/s}^2$ (EN 60068-2-6) $\leq 1000 \text{ m/s}^2$ (EN 60068-2-27)					
Operating temperature	$-10 \text{ }^\circ\text{C}$ to $70 \text{ }^\circ\text{C}$					
Mass	Scanning head	$\leq 18 \text{ g}$ (without cable)				
	Cable	20 g/m				
	Connecting element	M12 coupling: 15 g; D-sub connector: 32 g				

* Please select when ordering

¹⁾ $\pm 5 \mu\text{m}$ after linear length-error compensation in the subsequent electronics

²⁾ *Mitsubishi*: measuring length $\leq 2040 \text{ mm}$

Yaskawa: measuring length $\leq 1840 \text{ mm}$

³⁾ See *General electrical information* in the *Interfaces of HEIDENHAIN Encoders* brochure

⁴⁾ With LIC 411 FS scanning head: clock frequency: 8 MHz

LIC 4119

Absolute linear encoder with high accuracy for safety-related applications

- For measuring steps of down to 1 nm
- Steel scale tape adhesively bonded to mounting surface
- Consisting of a linear scale and scanning head
- Fault exclusion for the loosening of the mechanical connection

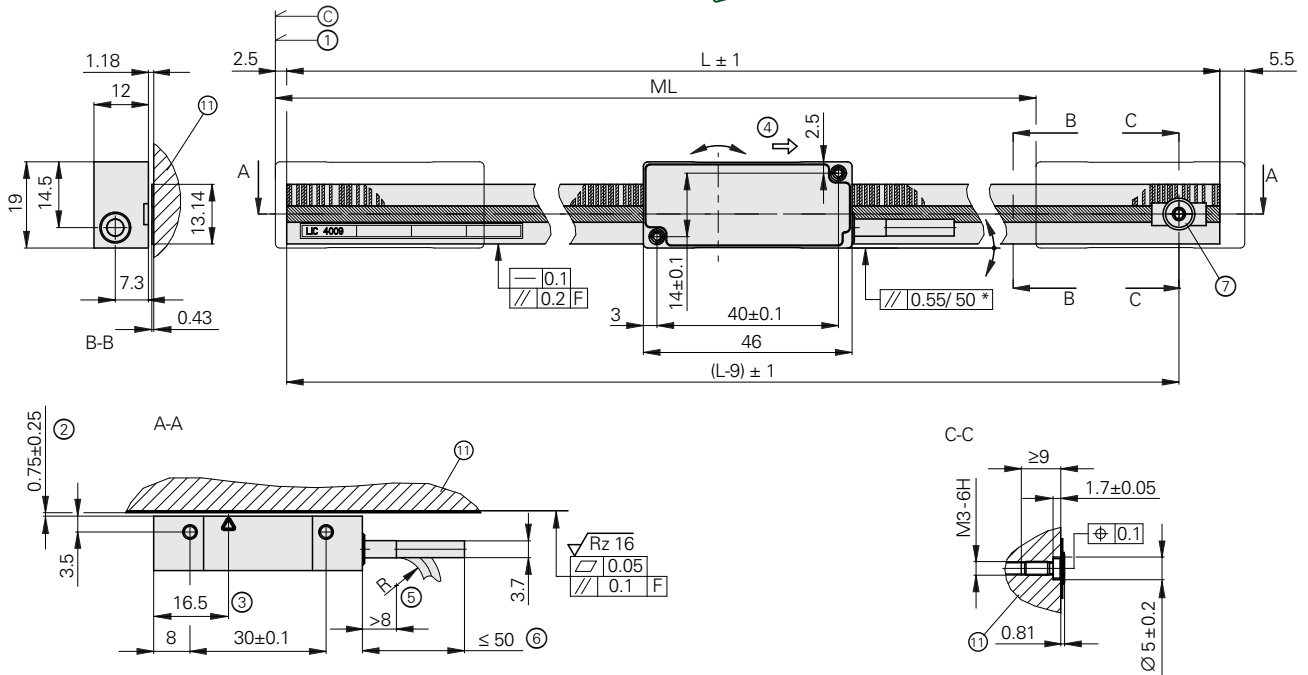

Mounting options for scanning head

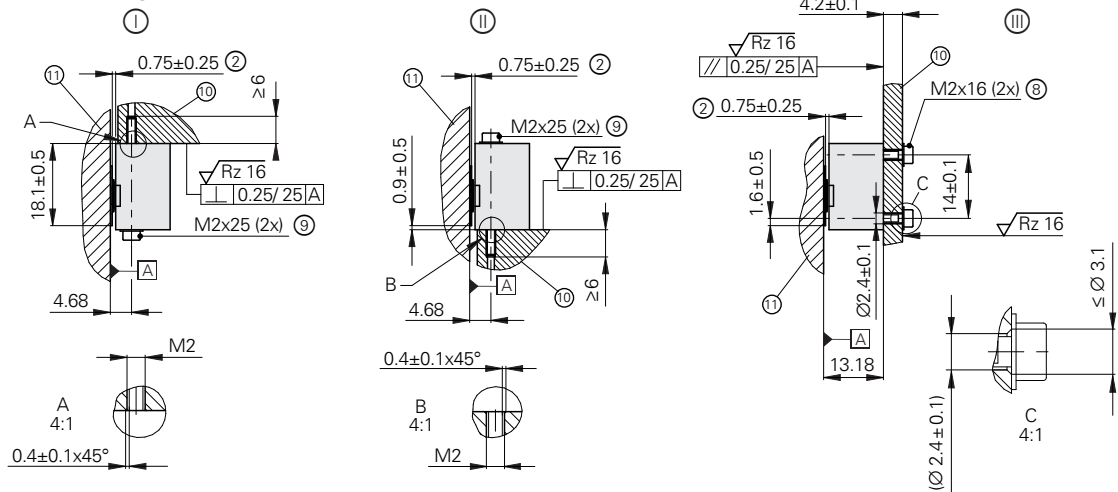

I, II, III = Mounting options

F = Machine guideway

* = Mounting error plus dynamic guideway error

C = Absolute track start value: 100 mm

ML = Measuring length

L = Scale tape length ($L = ML + 38$)

1 = Beginning of measuring length

2 = Mounting clearance between scanning head and scale tape

3 = Optical centerline

4 = Direction of motion of the scanning unit for ascending position values

5 = Bend radius R of the cable:

– Fixed cable ≥ 8 mm

– Frequent flexing ≥ 40 mm

6 = Cable support

7 = Screw (symmetrically aligned to the punched hole),

ISO 10664-10 hexalobular socket;

material bonding threadlocker required;

tightening torque = $40 \text{ Ncm} \pm 2.4 \text{ Ncm}$

8 = M2x16 ISO 4762 - 8.8 + ISO 7089 - 2 - 200HV

9 = M2x25 ISO 4762 - 8.8 + ISO 7089 - 2 - 200HV

10 = Angle bracket for scanning head

11 = Mounting surface for measuring standard



mm
Tolerancing ISO 8015
ISO 2768 - m H
 $\leq 6 \text{ mm}$: $\pm 0.2 \text{ mm}$



Scale	LIC 4009 
Measuring standard	Steel scale tape with absolute and incremental METALLUR track
Coefficient of linear expansion	$\alpha_{\text{therm}} \approx 10 \cdot 10^{-6} \text{ K}^{-1}$
Accuracy grade*	$\pm 3 \mu\text{m}^1$, $\pm 15 \mu\text{m}^2$
Baseline error	$\leq \pm 0.750 \mu\text{m}/50 \text{ mm}$ (typical)
Measuring length (ML)* in mm	70 120 170 220 270 320 370 420 520 620 720 820 920 ³⁾ 1020 ³⁾ 1220 ³⁾ 1420 ³⁾ 1620 ³⁾ 1820 ³⁾
Mass	Scale tape Screw
	31 g/m < 1 g
Protection ⁴⁾	IP00

Scanning head ⁵⁾	LIC 411 
Interface	EnDat 2.2
Ordering designation	EnDat22
Measuring step*	10 nm, 5 nm, 1 nm
Bit width	36 bits
Calculation time t_{cal} Clock frequency	$\leq 5 \mu\text{s}$ $\leq 16 \text{ MHz}$
Functional safety for applications with up to	<ul style="list-style-type: none"> • SIL 2 as per EN 61508 (further basis for testing: EN 61800-5-2) • Category 3, PL "d" as per EN ISO 13849-1:2015
PFH	$\leq 20 \cdot 10^{-9}$ (up to 6000 m above sea level)
Safe position ⁶⁾	Encoder: $\pm 550 \mu\text{m}$ (safety-relevant measuring step: SM = 220 μm); mechanical coupling: fault exclusions for the loosening of the scanning head and scale (see <i>Functional safety</i>)
Traversing speed ⁷⁾	$\leq 600 \text{ m/min}$
Interpolation error	$\pm 20 \text{ nm}$
Vibration 55 Hz to 2000 Hz Shock 11 ms	$\leq 200 \text{ m/s}^2$ (EN 60068-2-6) $\leq 200 \text{ m/s}^2$ (EN 60068-2-27)
Operating temperature	-10 °C to 70 °C
Relative air humidity	$\leq 93 \%$ (at 40 °C/4d as per EN 60068-2-78); condensation excluded
Protection EN 60529 ⁴⁾	IP67
Mass	Scanning head Cable Connector
	$\leq 18 \text{ g}$ (without cable) 20 g/m M12 coupling: 15 g; D-sub connector: 32 g

* Please select when ordering

¹⁾ Up to a measuring length of 1020 mm

²⁾ $\pm 5 \mu\text{m}$ after linear length-error compensation in the subsequent electronics

³⁾ Additional measuring length only on steel mounting surface

⁴⁾ In the application, the device must be protected from contamination by solids and liquids. If necessary, use a suitable enclosure with a gasket and sealing air.

⁵⁾ For the *electrical connection*, look under LIC 411 without functional safety

⁶⁾ Further tolerances may occur in subsequent electronics after position value comparison (contact manufacturer of subsequent electronics)

⁷⁾ See *General electrical information* in the *Interfaces of HEIDENHAIN Encoders* brochure



Scale	LIC 3107
Measuring standard	Steel scale tape with absolute track and incremental track
Coefficient of linear expansion	$\alpha_{\text{therm}} \approx 10 \cdot 10^{-6} \text{ K}^{-1}$
Accuracy grade	$\pm 15 \mu\text{m}^1$
Baseline error	$\leq \pm 0.750 \mu\text{m}/50 \text{ mm}$ (typical)
Scale tape cut from roll*	3 m, 5 m, 10 m
Mass	Scale tape Parts kit Scale tape carrier
	31 g/m 20 g 68 g/m

Scanning head	LIC 311	LIC 319F	LIC 319M	LIC 319P	LIC 319Y	
Interface	EnDat 2.2	Fanuc Serial Interface α_i	Mitsubishi high speed interface	Panasonic Serial Interface	Yaskawa Serial Interface	
Ordering designation*	EnDat22	Fanuc05	Mit03-4	Mit03-2	Pana02	YEC07
Measuring step	0.01 μm (10 nm)					
Calculation time t_{cal} Clock frequency	$\leq 5 \mu\text{s}$ $\leq 16 \text{ MHz}$	–				
Traversing speed²⁾	$\leq 600 \text{ m/min}$					
Interpolation error	$\pm 100 \text{ nm}$					
Electrical connection*	Cable (1 m or 3 m) with 8-pin M12 coupling (male) or 15-pin D-sub connector (male)					
Cable length (with HEIDENHAIN cable)	$\leq 100 \text{ m}$	$\leq 50 \text{ m}$	$\leq 30 \text{ m}$	$\leq 50 \text{ m}$		
Supply voltage	DC 3.6 V to 14 V					
Power consumption ²⁾ (max.)	At 3.6 V: $\leq 700 \text{ mW}$ At 14 V: $\leq 800 \text{ mW}$	At 3.6 V: $\leq 850 \text{ mW}$ At 14 V: $\leq 950 \text{ mW}$				
Current consumption (typical)	At 5 V: 75 mA (without load)	At 5 V: 95 mA (without load)				
Vibration 55 Hz to 2000 Hz Shock 6 ms	$\leq 500 \text{ m/s}^2$ (EN 60068-2-6) $\leq 1000 \text{ m/s}^2$ (EN 60068-2-27)					
Operating temperature	$-10 \text{ }^\circ\text{C}$ to $70 \text{ }^\circ\text{C}$					
Mass	Scanning head Cable Connecting element	$\leq 18 \text{ g}$ (without cable) 20 g/m M12 coupling: 15 g; D-sub connector: 32 g				

* Please select when ordering

¹⁾ $\pm 5 \mu\text{m}$ after linear length-error compensation in the subsequent electronics

²⁾ See *General electrical information* in the *Interfaces of HEIDENHAIN Encoders* brochure

LIC 3119, LIC 3199

Absolute linear encoders for measuring lengths of up to 10 m

- For measuring steps of down to 10 nm
- Steel scale tape adhesively bonded to mounting surface
- Consisting of a linear scale and scanning head

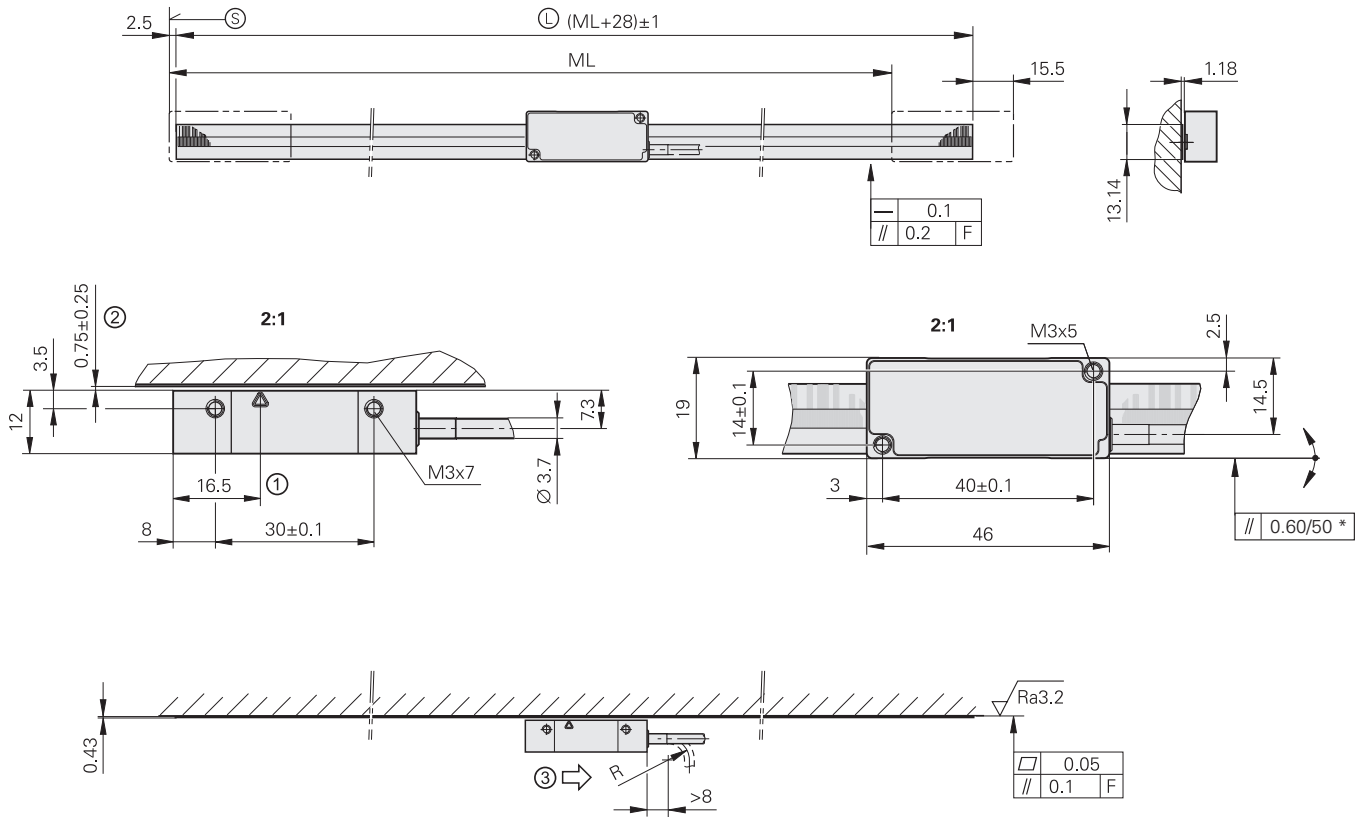

Mounting options for scanning head

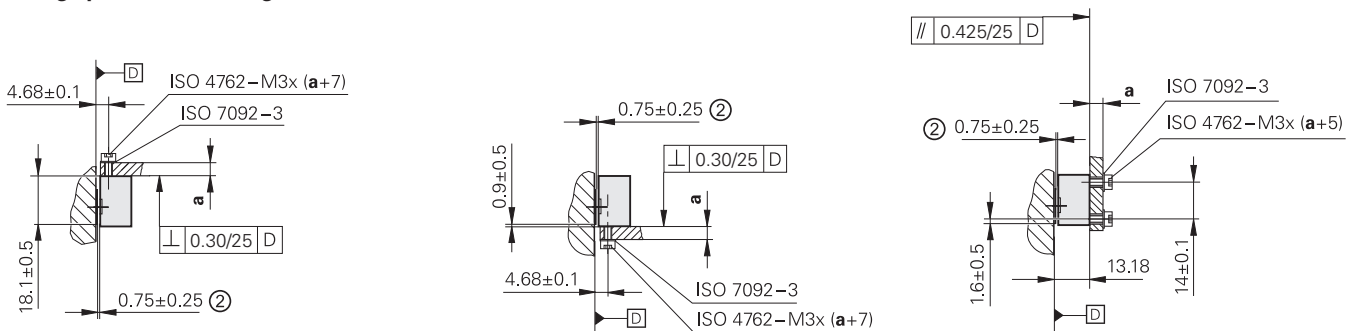

mm

 Tolerancing ISO 8015
 ISO 2768 - m H
 < 6 mm: ±0.2 mm

- F = Machine guideway
- * = Mounting error plus dynamic guideway error
- ⊙ = Beginning of measuring length (ML)
- ⊙ = Scale tape length
- 1 = Optical centerline
- 2 = Mounting clearance between scanning head and linear scale
- 3 = Direction of motion of the scanning unit for ascending position values



Scale	LIC 3109
Measuring standard Coefficient of linear expansion	Steel scale tape with absolute track and incremental track $\alpha_{\text{therm}} \approx 10 \cdot 10^{-6} \text{ K}^{-1}$
Accuracy grade	$\pm 15 \mu\text{m}^{1)}$
Baseline error	$\leq \pm 0.750 \mu\text{m}/50 \text{ mm}$ (typical)
Scale tape cut from roll*	3 m, 5 m, 10 m
Mass	31 g/m

Scanning head	LIC 311	LIC 319F	LIC 319M	LIC 319P	LIC 319Y	
Interface	EnDat 2.2	Fanuc Serial Interface αi	Mitsubishi high speed interface	Panasonic Serial Interface	Yaskawa Serial Interface	
Ordering designation*	EnDat22	Fanuc05	Mit03-4	Mit03-2	Pana02	YEC07
Measuring step	0.01 μm (10 nm)					
Calculation time t_{cal} Clock frequency	$\leq 5 \mu\text{s}$ $\leq 16 \text{ MHz}$	–				
Traversing speed²⁾	$\leq 600 \text{ m/min}$					
Interpolation error	$\pm 100 \text{ nm}$					
Electrical connection*	Cable (1 m or 3 m) with 8-pin M12 coupling (male) or 15-pin D-sub connector (male)					
Cable length (with HEIDENHAIN cable)	$\leq 100 \text{ m}$	$\leq 50 \text{ m}$	$\leq 30 \text{ m}$	$\leq 50 \text{ m}$		
Supply voltage	DC 3.6 V to 14 V					
Power consumption ²⁾ (max.)	At 3.6 V: $\leq 700 \text{ mW}$ At 14 V: $\leq 800 \text{ mW}$	At 3.6 V: $\leq 850 \text{ mW}$ At 14 V: $\leq 950 \text{ mW}$				
Current consumption (typical)	At 5 V: 75 mA (without load)	At 5 V: 95 mA (without load)				
Vibration 55 Hz to 2000 Hz Shock 6 ms	$\leq 500 \text{ m/s}^2$ (EN 60068-2-6) $\leq 1000 \text{ m/s}^2$ (EN 60068-2-27)					
Operating temperature	$-10 \text{ }^\circ\text{C}$ to $70 \text{ }^\circ\text{C}$					
Mass	Scanning head	$\leq 18 \text{ g}$ (without cable)				
	Cable	20 g/m				
	Connecting element	M12 coupling: 15 g; D-sub connector: 32 g				

* Please select when ordering

¹⁾ $\pm 5 \mu\text{m}$ after linear length-error compensation in the subsequent electronics

²⁾ See *General electrical information* in the *Interfaces of HEIDENHAIN Encoders* brochure

LIC 2117, LIC 2197

Absolute linear encoders for measuring lengths of up to 3 m

- Measuring step: 100 nm or 50 nm
- Steel scale tape pulled through aluminum extrusions and fastened at center
- Consisting of a linear scale and scanning head

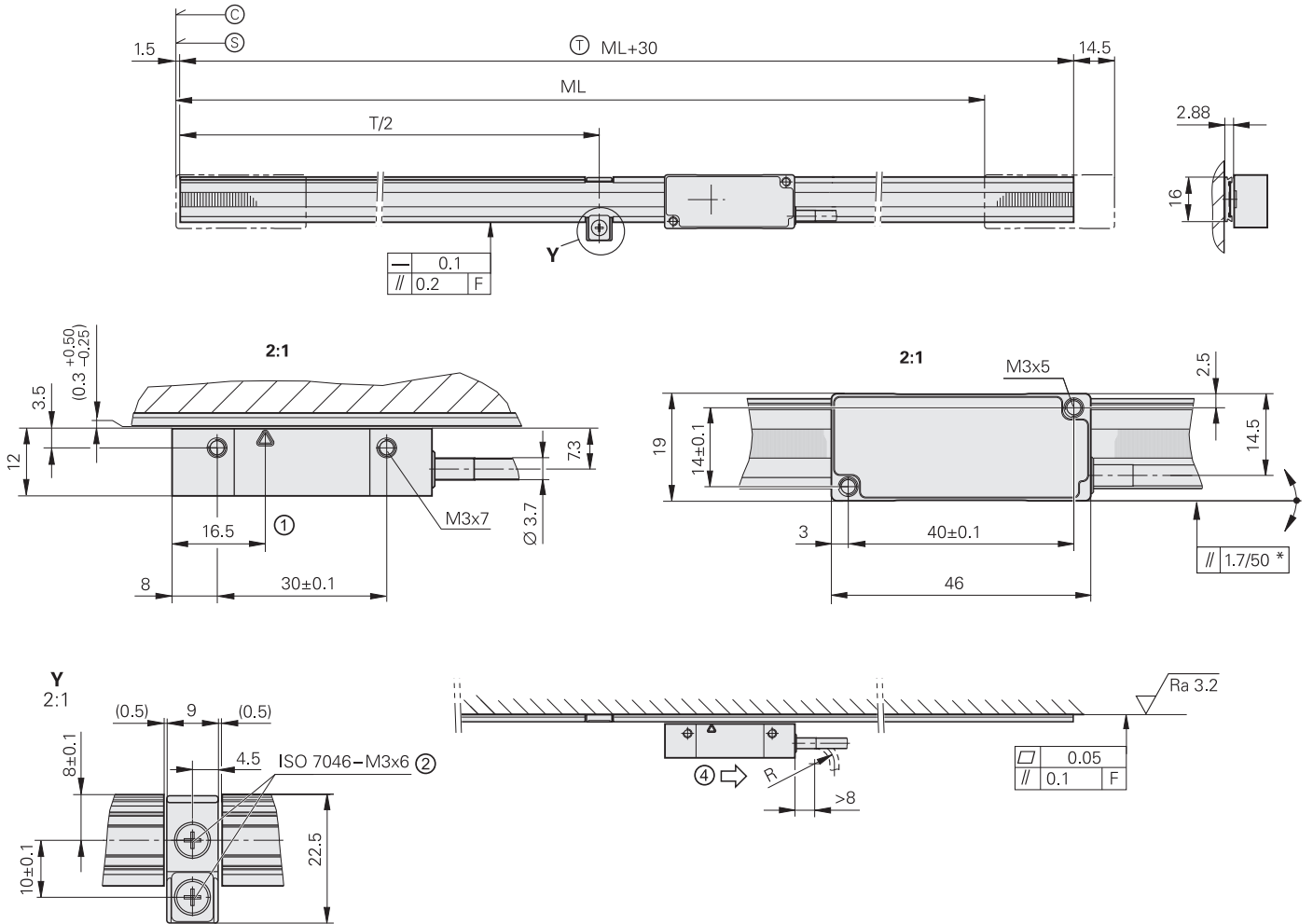

Mounting options for scanning head

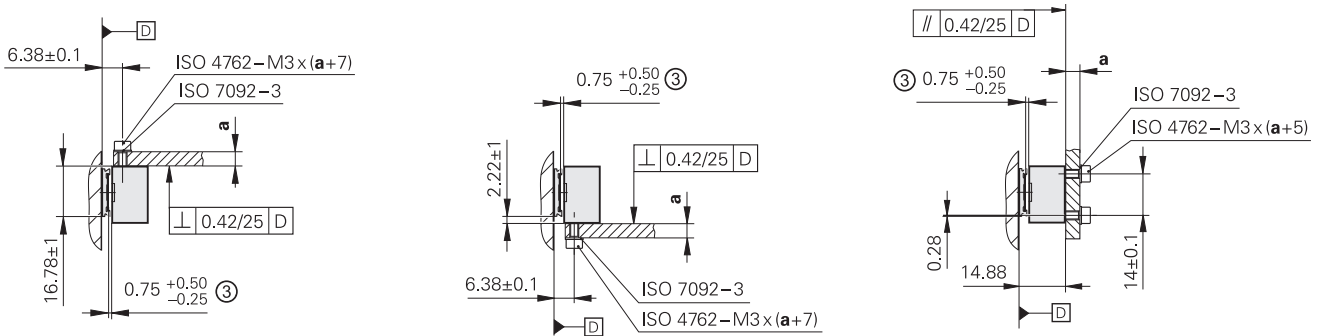

mm



Tolerancing ISO 8015

ISO 2768 - m H

< 6 mm: ±0.2 mm

F = Machine guideway

* = Maximum change during operation

⊙ = Absolute track start value: 100 mm

⊙ = Beginning of measuring length (ML)

⊙ = Carrier length

1 = Optical centerline

2 = M3 threaded mating hole; depth: 5 mm

3 = Mounting clearance between scanning head and scale tape

4 = Direction of motion of the scanning unit for ascending position values



Scale	LIC 2107
Measuring standard Coefficient of linear expansion	Steel scale tape with absolute track $\alpha_{\text{therm}} \approx 10 \cdot 10^{-6} \text{ K}^{-1}$
Accuracy grade	$\pm 15 \mu\text{m}$
Measuring length (ML)* in mm	120 320 520 770 1020 1220 1520 2020 2420 3020 (greater measuring lengths (up to 6020 mm) upon request)
Mass Scale tape Scale tape carrier	20 g/m 70 g/m

Scanning head	LIC 211	LIC 219F	LIC 219M	LIC 219P	LIC 219Y	
Interface	EnDat 2.2	Fanuc Serial Interface αi	Mitsubishi high speed interface	Panasonic Serial Interface	Yaskawa Serial Interface	
Ordering designation*	EnDat22	Fanuc05	Mit03-4	Mit03-2	Pana02	YEC07
Measuring step*	100 nm, 50 nm					
Bit width	32 bits					
Calculation time t_{cal} Clock frequency	$\leq 5 \mu\text{s}$ $\leq 16 \text{ MHz}$	– –				
Traversing speed¹⁾	$\leq 600 \text{ m/min}$					
Interpolation error	$\pm 2 \mu\text{m}$					
Electrical connection*	Cable (1 m or 3 m) with 8-pin M12 coupling (male) or 15-pin D-sub connector (male)					
Cable length (with HEIDENHAIN cable)	$\leq 100 \text{ m}$	$\leq 50 \text{ m}$	$\leq 30 \text{ m}$	$\leq 50 \text{ m}$		
Supply voltage	DC 3.6 V to 14 V					
Power consumption ¹⁾ (max.)	At 3.6 V: $\leq 700 \text{ mW}$ At 14 V: $\leq 800 \text{ mW}$	At 3.6 V: $\leq 850 \text{ mW}$ At 14 V: $\leq 950 \text{ mW}$				
Current consumption (typical)	At 5 V: 75 mA (without load)	At 5 V: 95 mA (without load)				
Vibration 55 Hz to 2000 Hz Shock 6 ms	$\leq 500 \text{ m/s}^2$ (EN 60068-2-6) $\leq 1000 \text{ m/s}^2$ (EN 60068-2-27)					
Operating temperature	$-10 \text{ }^\circ\text{C}$ to $70 \text{ }^\circ\text{C}$					
Mass Scanning head Cable Connecting element	$\leq 18 \text{ g}$ (without cable) 20 g/m M12 coupling: 15 g; D-sub connector: 32 g					

* Please select when ordering

¹⁾ See *General electrical information* in the *Interfaces of HEIDENHAIN Encoders* brochure

LIC 2119, LIC 2199

Absolute linear encoders for measuring lengths of up to 3 m

- Measuring step: 100 nm or 50 nm
- Steel scale tape adhesively bonded to mounting surface
- Consisting of a linear scale and scanning head

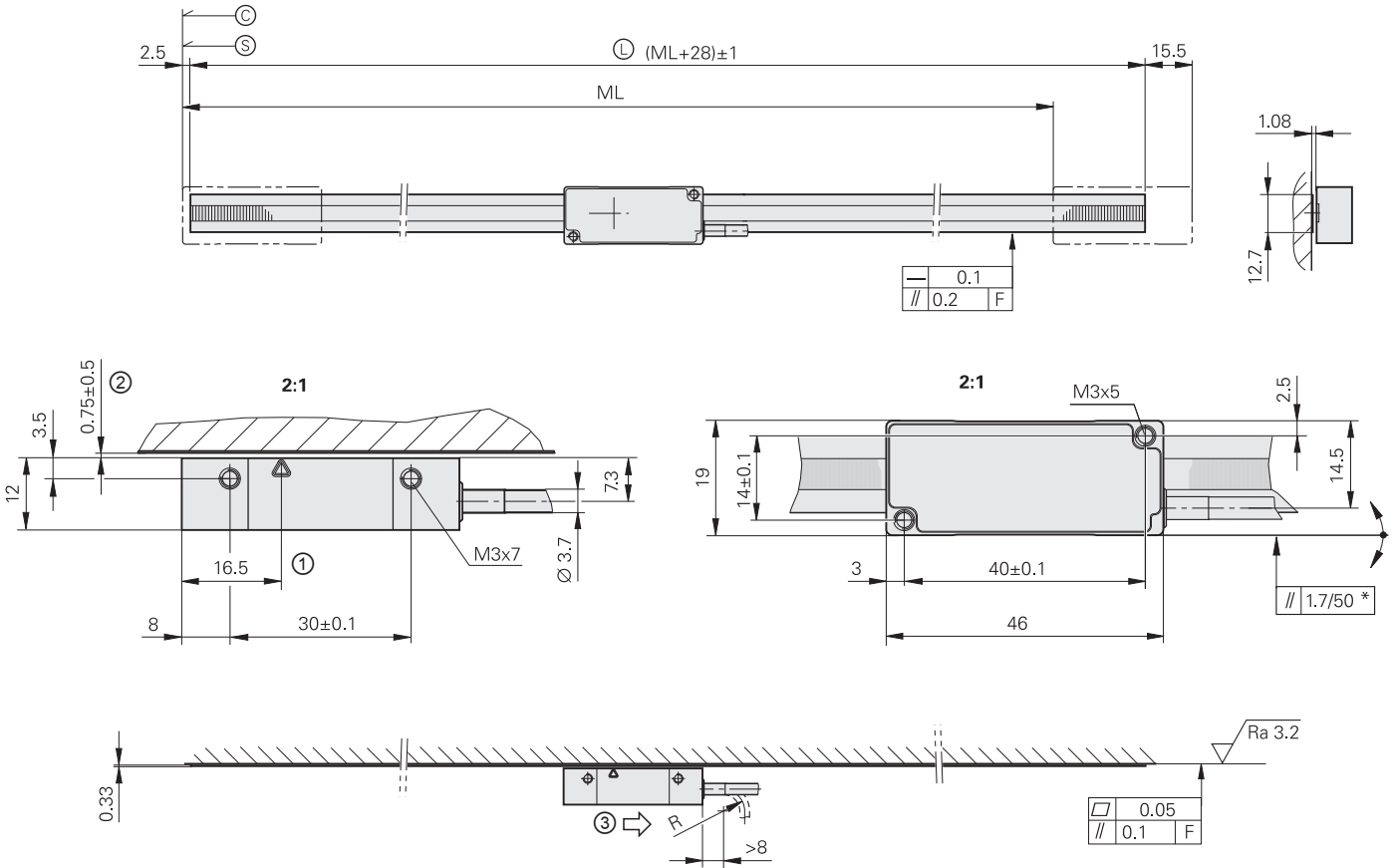

Mounting options for scanning head

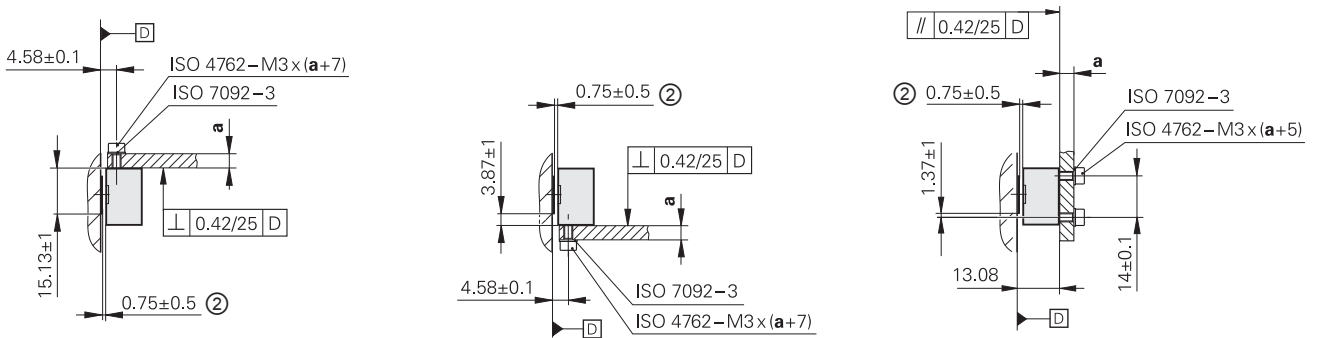

mm

 Tolerancing ISO 8015
 ISO 2768 - m H
 < 6 mm: ±0.2 mm

- F = Machine guideway
- * = Maximum change during operation
- ⊙ = Absolute track start value: 100 mm
- ⊙ = Beginning of measuring length (ML)
- ⊙ = Scale tape length
- 1 = Optical centerline
- 2 = Mounting clearance between scanning head and scale tape
- 3 = Direction of motion of the scanning unit for ascending position values



Scale	LIC 2109
Measuring standard Coefficient of linear expansion	Steel scale tape with absolute track $\alpha_{\text{therm}} \approx 10 \cdot 10^{-6} \text{ K}^{-1}$
Accuracy grade	$\pm 15 \mu\text{m}$
Measuring length (ML)* in mm	120 320 520 770 1020 1220 1520 2020 2420 3020 (greater measuring lengths (up to 6020 mm) upon request)
Mass	20 g/m

Scanning head	LIC 211	LIC 219F	LIC 219M		LIC 219P	LIC 219Y
Interface	EnDat 2.2	Fanuc Serial Interface αi	Mitsubishi high speed interface		Panasonic Serial Interface	Yaskawa Serial Interface
Ordering designation*	EnDat22	Fanuc05	Mit03-4	Mit03-2	Pana02	YEC07
Measuring step*	100 nm, 50 nm					
Bit width	32 bits					
Calculation time t_{cal} Clock frequency	$\leq 5 \mu\text{s}$ $\leq 16 \text{ MHz}$	– –				
Traversing speed¹⁾	$\leq 600 \text{ m/min}$					
Interpolation error	$\pm 2 \mu\text{m}$					
Electrical connection*	Cable (1 m or 3 m) with 8-pin M12 coupling (male) or 15-pin D-sub connector (male)					
Cable length (with HEIDENHAIN cable)	$\leq 100 \text{ m}$	$\leq 50 \text{ m}$	$\leq 30 \text{ m}$		$\leq 50 \text{ m}$	
Supply voltage	DC 3.6 V to 14 V					
Power consumption ¹⁾ (max.)	At 3.6 V: $\leq 700 \text{ mW}$ At 14 V: $\leq 800 \text{ mW}$		At 3.6 V: $\leq 850 \text{ mW}$ At 14 V: $\leq 950 \text{ mW}$			
Current consumption (typical)	At 5 V: 75 mA (without load)		At 5 V: 95 mA (without load)			
Vibration 55 Hz to 2000 Hz Shock 6 ms	$\leq 500 \text{ m/s}^2$ (EN 60068-2-6) $\leq 1000 \text{ m/s}^2$ (EN 60068-2-27)					
Operating temperature	$-10 \text{ }^\circ\text{C}$ to $70 \text{ }^\circ\text{C}$					
Mass	Scanning head	$\leq 18 \text{ g}$ (without cable)				
	Cable	20 g/m				
	Connecting element	M12 coupling: 15 g; D-sub connector: 32 g				

* Please select when ordering

¹⁾ See *General electrical information* in the *Interfaces of HEIDENHAIN Encoders* brochure

LIP 382

Incremental linear encoders with very high accuracy

- Measuring steps < 1 nm
- Measuring standard fastened by screws

ML 270

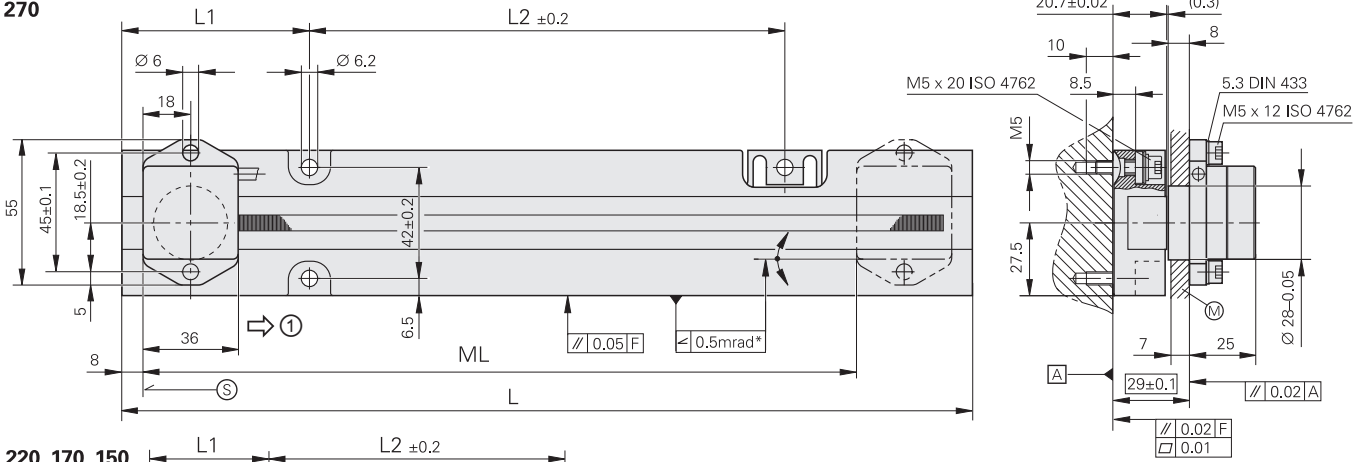

ML 220, 170, 150

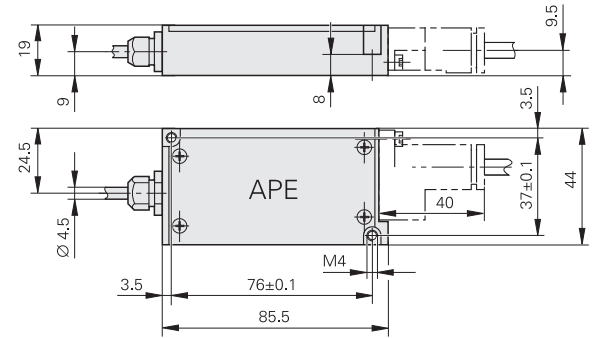
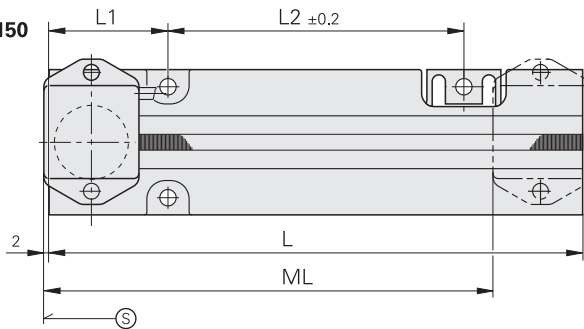

ML 70, 120

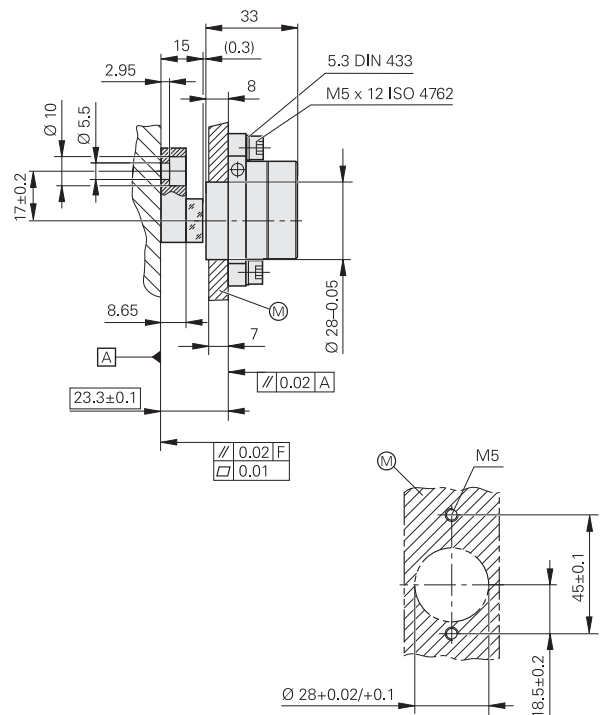
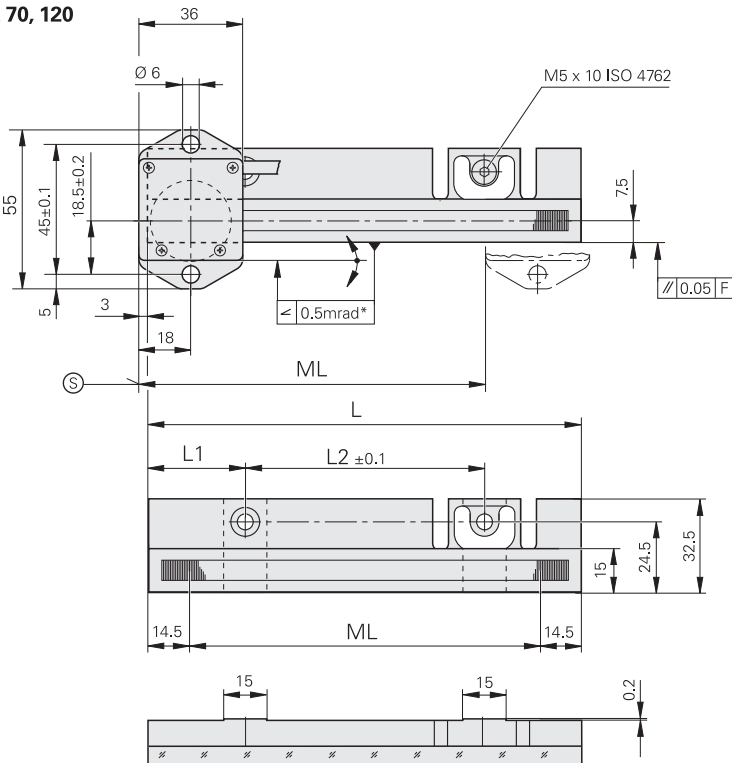

mm

Tolerancing ISO 8015
ISO 2768 - m H
< 6 mm: ± 0.2 mm

- * = Maximum change during operation
- F = Machine guideway
- ⊙ = Beginning of measuring length (ML)
- Ⓜ = Mounting surface for scanning head
- 1 = Direction of motion of the scanning unit for ascending position values

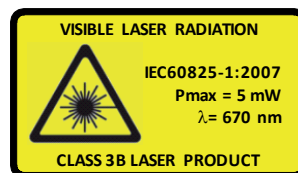

ML	L	L1	L2
70	100	22.5	55
120	150	33.5	83
150	182	40	102
170	202	45	112
220	252	56	140
270	322	71	180

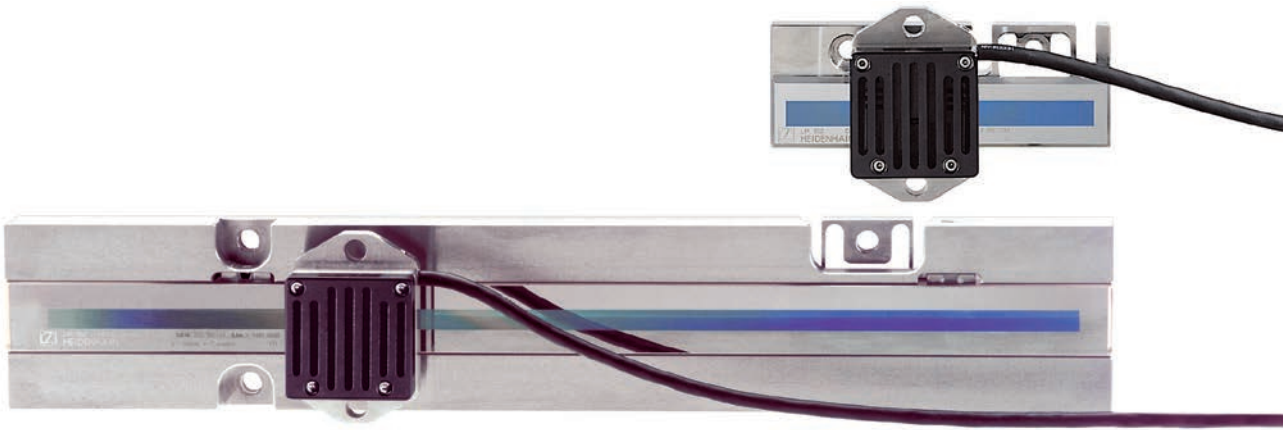

		LIP 382
Measuring standard		DIADUR phase grating on Zerodur glass ceramic; grating period: 0.512 μm
Coefficient of linear expansion		$\alpha_{\text{therm}} = (0 \pm 0.1) \cdot 10^{-6} \text{ K}^{-1}$
Accuracy grade		$\pm 0.5 \mu\text{m}$ (higher accuracy grades upon request)
Baseline error		$\leq \pm 0.075 \mu\text{m}/5 \text{ mm}$
Measuring length (ML)*		70 120 150 170 220 270
in mm		
Reference marks		No
Interface		$\sim 1 \text{ V}_{\text{PP}}$
Integrated interpolation		–
Signal period		0.128 μm
Cutoff frequency	–3 dB	$\geq 1 \text{ MHz}$
Scanning frequency*		–
Edge separation <i>a</i>		
Traversing speed		$\leq 7.6 \text{ m/min}$
Interpolation error		$\pm 0.01 \text{ nm}$
RMS position noise		0.06 nm (1 MHz ¹⁾)
Laser		Mounted scanning head and scale: Class 1 Non-mounted scanning head: Class 3B Laser diode used: Class 3B
Electrical connection		Cable (0.5 m) to interface electronics (APE), separate adapter cable (1 m/3 m/6 m/9 m) connectable to APE
Cable length		See the interface description; however, $\leq 30 \text{ m}$ (with HEIDENHAIN cable)
Supply voltage		DC 5 V $\pm 0.25 \text{ V}$
Current consumption		$< 190 \text{ mA}$
Vibration 55 Hz to 2000 Hz		$\leq 4 \text{ m/s}^2$ (EN 60068-2-6)
Shock 11 ms		$\leq 50 \text{ m/s}^2$ (EN 60068-2-27)
Operating temperature		0 °C to 40 °C
Mass	Scanning head	150 g
	Interface electronics	100 g
	Scale	ML 70 mm: 260 g, ML $\geq 150 \text{ mm}$: 700 g
	Cable	38 g/m

* Please select when ordering

¹⁾ –3 dB cutoff frequency of the subsequent electronics

LIP 211, LIP 281, LIP 291

Incremental linear encoders for very high accuracy and high position stability

- For measuring steps of 1 nm and smaller
- For high traversing speeds and large measuring lengths
- Measuring standard secured with fixing clamps
- Consisting of a linear scale and scanning head

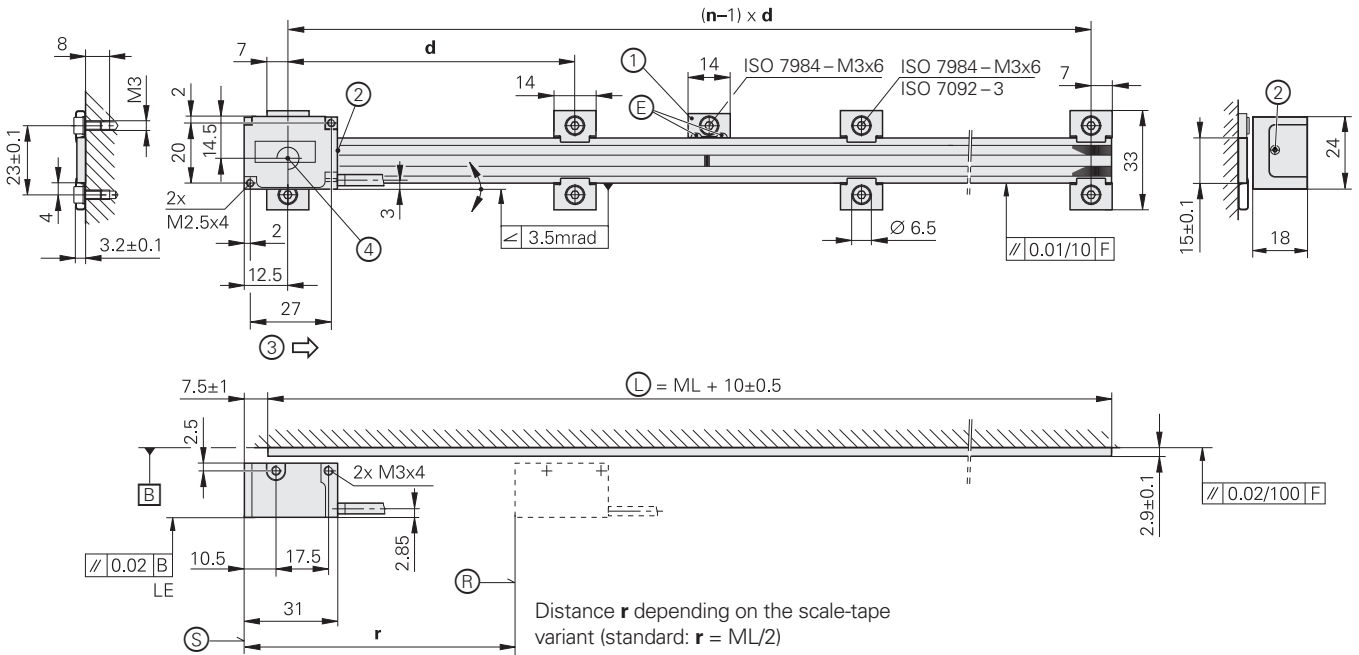

Quantity **n** of fixing clamp pairs (clamps on both sides)

ML	n
70 < ML ≤ 100	3
100 < ML ≤ 200	4
...	...

Distance **d** between pairs of fixing clamps:

$$d = \frac{ML - 4}{n - 1}$$

Mounting options for scanning head

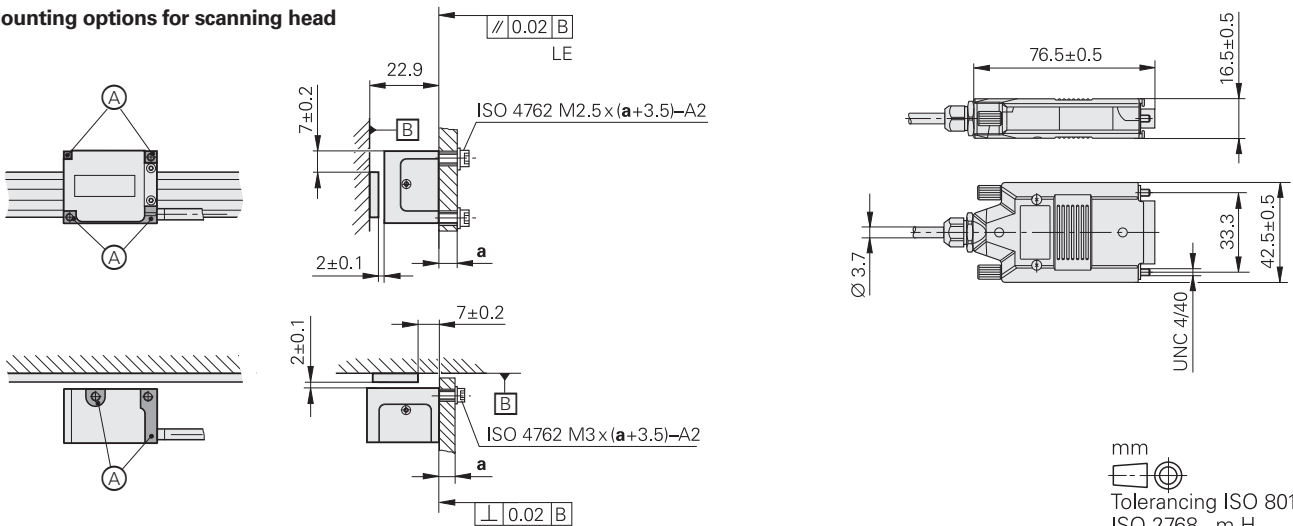

- F = Machine guideway
- ⊗ = Reference mark position
- ⊕ = Scale length
- ⊙ = Beginning of measuring length (ML)
- ⊕ = Adhesive as per the mounting instructions
- ⊙ = Mounting surface
- 1 = Mounting element for hard adhesive bond for defining the thermal fixed point
- 2 = Maximum protrusion of screw head: 0.5 mm
- 3 = Direction of motion of the scanning unit for ascending position values
- 4 = Optical centerline

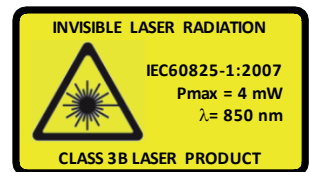



Scale	LIP 201																																															
Measuring standard Coefficient of linear expansion	OPTODUR phase grating on Zerodur glass ceramic; grating period 2.048 μm $\alpha_{\text{therm}} = (0 \pm 0.1) \cdot 10^{-6} \text{ K}^{-1}$																																															
Accuracy grade*	$\pm 1 \mu\text{m}$							$\pm 3 \mu\text{m}$ (higher accuracy grades upon request)																																								
Baseline error	$\leq \pm 0.125 \mu\text{m}/5 \text{ mm}$																																															
Measuring length (ML)* in mm	20	30	50	70	120	170	220	370	420	470	520	570	620	670	270	320	370	420	470	520	570	720	770	820	870	920	970	1020	620	670	720	770	820	870	920	1140	1240	1340	1440	1540	1640	1840	2040	2240	2440	2640	2840	3040
Reference marks	One at midpoint of measuring length																																															
Mass	1.1 g + 0.11 g/mm of measuring length																																															

Scanning head	LIP 21	LIP 29F	LIP 29M	LIP 28
Interface	EnDat 2.2 ¹⁾	Fanuc Serial Interface ¹⁾	Mitsubishi high speed ¹⁾	$\sim 1 V_{\text{PP}}$
Ordering designation	EnDat22	Fanuc02	Mit02-4	–
Integrated interpolation	16384-fold (14 bits)			–
Clock frequency	$\leq 16 \text{ MHz}$	–	–	–
Calculation time t_{cal}	$\leq 5 \mu\text{s}$	–	–	–
Measuring step	0.03125 nm (31.25 μm)			–
Signal period	–	–	–	0.512 μm
Cutoff frequency –3 dB	–	–	–	$\geq 3 \text{ MHz}$
Traversing speed	$\leq 120 \text{ m/min}$			$\leq 90 \text{ m/min}$
Interpolation error RMS position noise	$\pm 0.4 \text{ nm}^4$ 0.12 nm			$\pm 0.4 \text{ nm}^4$ 0.12 nm (3 MHz ³⁾)
Electrical connection*	Cable (0.5 m or 1 m; 2 m and 3 m for 1 V_{PP}), with interface electronics in the connector (15-pin D-sub (male))			
Cable length	See interface description; however, $\leq 15 \text{ m}$ ($\leq 30 \text{ m}$ for 1 V_{PP}) with HEIDENHAIN cable; during signal adjustment with the PWM 21: $\leq 3 \text{ m}$			
Supply voltage	DC 3.6 V to 14 V			DC 5 V $\pm 0.25 \text{ V}$
Power consumption ²⁾ (max.)	At 14 V: 2500 mW; at 3.6 V: 2600 mW			–
Current consumption	At 5 V: 300 mA (without load, typical)			$\leq 390 \text{ mA}$
Laser	Mounted scanning head and scale: Class 1; non-mounted scanning head: Class 3B			
Vibration 55 Hz to 2000 Hz Shock 11 ms	$\leq 200 \text{ m/s}^2$ (IEC 60068-2-6) $\leq 400 \text{ m/s}^2$ (IEC 60068-2-27)			
Operating temperature	0 °C to 50 °C			
Mass	Scanning head: 59 g; connector: 140 g; cable: 22 g/m			

* Please select when ordering; for measuring lengths < 70 mm, the "adhesively bonded" mounting type is recommended

¹⁾ Absolute position value after traverse of the reference mark in "position value 2"

²⁾ See *General electrical information* in the *Interfaces of HEIDENHAIN Encoders* brochure

³⁾ –3 dB cutoff frequency of the subsequent electronics

⁴⁾ With HEIDENHAIN interface electronics

LIP 6071, LIP 6081

Incremental linear encoders with very high accuracy

- For limited installation space
- For measuring steps of down to 1 nm
- For high traversing speeds and large measuring lengths
- Position detection through homing track and limit switches
- Measuring standard secured with adhesive or fixing clamps

Scale, clamped

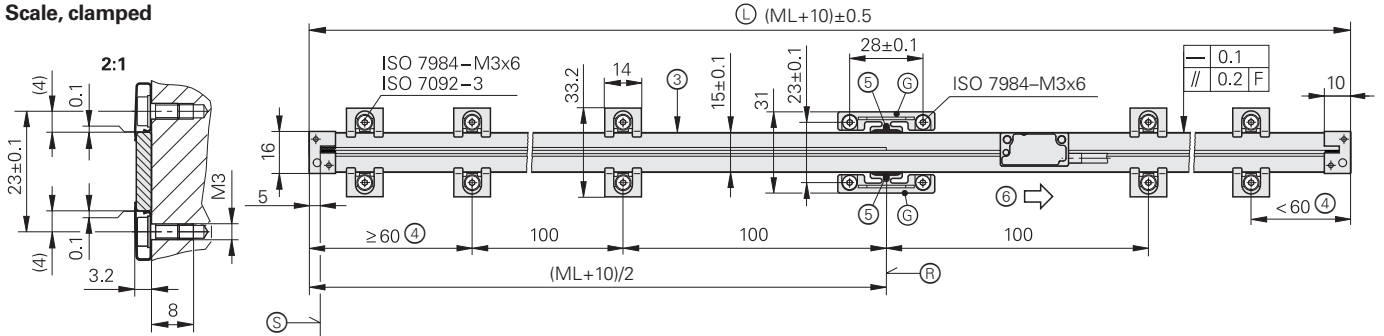

Scale, adhesively bonded

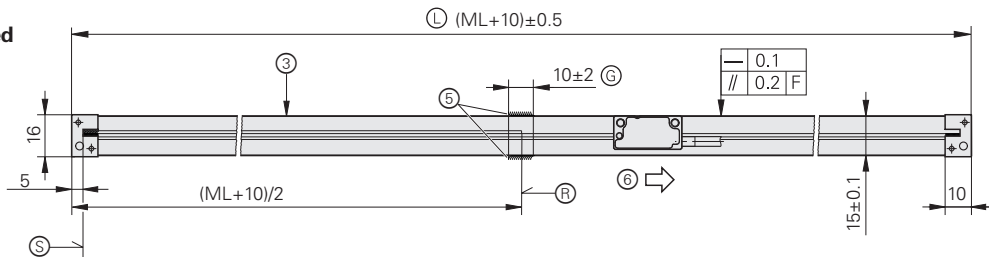

Scanning head and scale clamped / adhesively bonded

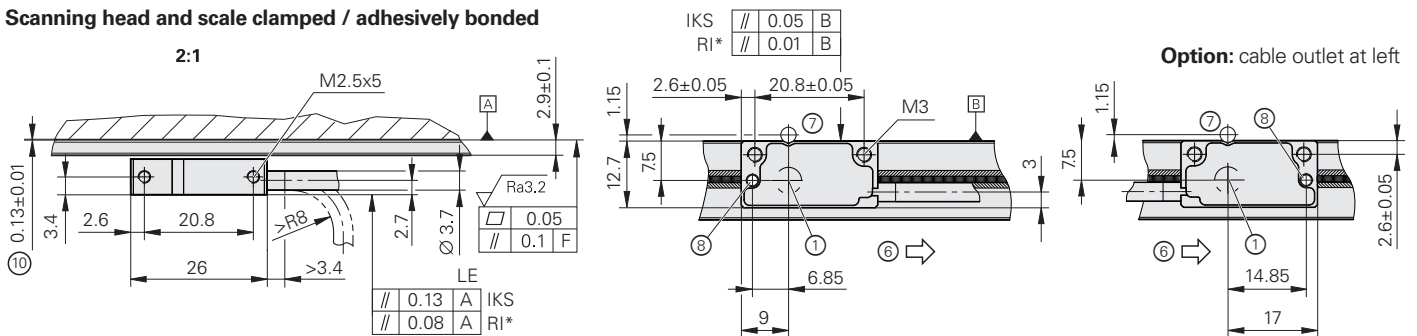

Mounting options for scanning head

(shown without fixing clamps)

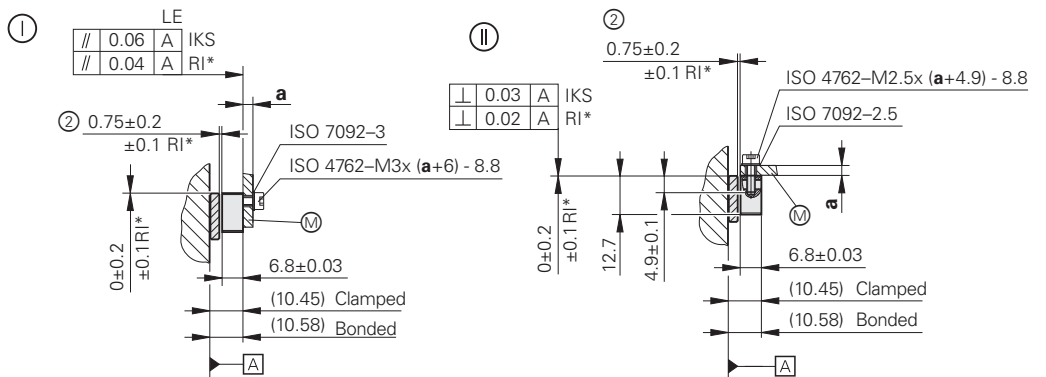

- F = Machine guideway
- * = Maximum change during operation
- IKS = Incremental track
- RI = Reference mark track
- M = Mounting surface
- L = Scale length
- Ⓢ = Beginning of measuring length (ML)
- Ⓣ = Fixed point for defining the thermal fixed point
- Ⓡ = Reference mark position
- 1 = Optical centerline
- 2 = Mounting clearance of scanning head to scale; adjusted by means of a spacer shim
- 3 = Scale stop surface
- 4 = Use additional fixing clamp pair depending on the measuring length (ML)
- 5 = Adhesive
- 6 = Direction of motion of the scanning unit for ascending position values
- 7 = Moiré adjustment option 1: alignment pin, \varnothing 3mm, possible only with mounting option ①
- 8 = Moiré adjustment option 2: alignment pin, \varnothing 2mm
- 9 = Recommended: \varnothing 3
- 10 = Adhesive tape (only if the scale is adhesively bonded)

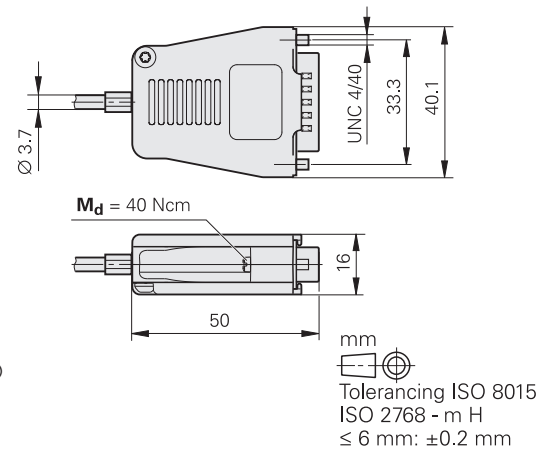

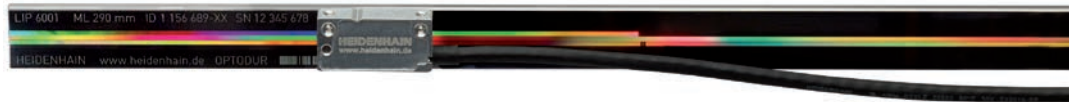

Scale		LIP 6001													
Measuring standard* Coefficient of linear expansion		OPTODUR phase grating on Zerodur glass ceramic or glass; grating period: 8 µm $\alpha_{\text{therm}} = (0 \pm 0.1) \cdot 10^{-6} \text{ K}^{-1}$ (Zerodur glass ceramic); $\alpha_{\text{therm}} \approx 8 \cdot 10^{-6} \text{ K}^{-1}$ (glass)													
Accuracy grade*		$\pm 1 \text{ µm}$ (only for Zerodur glass ceramic up to a measuring length of 1020 mm); $\pm 3 \text{ µm}$													
Baseline error		$\leq \pm 0.175 \text{ µm/5 mm}$													
Measuring length (ML)* in mm		20	30	50	70	120	170	220	270	320	370	420	470	520	570
		620	670	720	770	820	870	920	970	1020	1140	1240	1340	1440	1540
		1640	1840	2040	2240	2440	2640	2840	3040						
Reference mark		One at midpoint of measuring length													
Mass		1.1 g + 0.11 g/mm of measuring length													
Scanning head		LIP 608	LIP 607												
Interface		$\sim 1 \text{ V}_{\text{PP}}$	TTL ¹⁾												
Integrated interpolation* Signal period		– 4 µm	5-fold 0.8 µm	10-fold 0.4 µm	25-fold 0.16 µm	50-fold 0.08 µm	100-fold 0.04 µm	500-fold 0.008 µm							
Cutoff frequency –3 dB		$\geq 1 \text{ MHz}$													
Scanning frequency		–	– $\leq 312.5 \text{ kHz}$	– $\leq 312.5 \text{ kHz}$	$\leq 250 \text{ kHz}$ $\leq 125 \text{ kHz}$ $\leq 62.5 \text{ kHz}$	$\leq 125 \text{ kHz}$ $\leq 62.5 \text{ kHz}$ $\leq 31.25 \text{ kHz}$	$\leq 62.5 \text{ kHz}$ $\leq 31.25 \text{ kHz}$ $\leq 15.63 \text{ kHz}$	$\leq 31.25 \text{ kHz}$ $\leq 15.63 \text{ kHz}$ $\leq 7.81 \text{ kHz}$	$\leq 12.5 \text{ kHz}$ $\leq 6.25 \text{ kHz}$ $\leq 3.13 \text{ kHz}$						
Edge separation <i>a</i>		–	– $\geq 0.135 \text{ µs}$	– $\geq 0.07 \text{ µs}$ $\geq 0.135 \text{ µs}$	$\geq 0.03 \text{ µs}$ $\geq 0.07 \text{ µs}$ $\geq 0.135 \text{ µs}$										
Traversing speed ²⁾		$\leq 240 \text{ m/min}$	– $\leq 75 \text{ m/min}$	– $\leq 75 \text{ m/min}$ $\leq 37 \text{ m/min}$	$\leq 60 \text{ m/min}$ $\leq 30 \text{ m/min}$ $\leq 15 \text{ m/min}$	$\leq 30 \text{ m/min}$ $\leq 15 \text{ m/min}$ $\leq 7.5 \text{ m/min}$	$\leq 15 \text{ m/min}$ $\leq 7.5 \text{ m/min}$ $\leq 3.7 \text{ m/min}$	$\leq 3 \text{ m/min}$ $\leq 1.5 \text{ m/min}$ $\leq 0.75 \text{ m/min}$							
Interpolation error RMS position noise		$\pm 4 \text{ nm}$ 0.4 nm (1 MHz ³⁾)	–												
Electrical connection*		Cable outlet on the left or right and straight or angled <i>1 V_{PP}</i> : cable (0.5 m/1 m/3 m) with 15-pin D-sub connector (male) <i>TTL</i> : cable (0.5 m or 1 m) with interface electronics in the 15-pin D-sub connector (male)													
Cable length		With HEIDENHAIN cable: homing, limit: $\leq 10 \text{ m}$; only incremental: $\leq 20 \text{ m}$; during signal adjustment with the PWM 21: $\leq 3 \text{ m}$													
Supply voltage		DC 5 V $\pm 0.5 \text{ V}$													
Current consumption		$\leq 150 \text{ mA}$	$\leq 300 \text{ mA}$ (without load)												
Vibration 55 Hz to 2000 Hz Shock 6 ms		$\leq 500 \text{ m/s}^2$ (IEC 60068-2-6) $\leq 1000 \text{ m/s}^2$ (IEC 60068-2-27)													
Operating temperature		-10 °C to 70 °C													
Mass		Scanning head Connector Cable	$\approx 5 \text{ g}$ (without cable) AK LIP 608 $\approx 71 \text{ g}$; AK LIP 607 $\approx 74 \text{ g}$ $\approx 24 \text{ g/m}$												

* Please select when ordering; for measuring lengths < 70 mm, the "adhesively bonded" mounting type is recommended

¹⁾ Unlocked TTLx1 possible upon request ²⁾ With TTL: maximum traversing speed during referencing: 16.8 m/min (70 kHz)

³⁾ –3dB cutoff frequency of the subsequent electronics



Scale	LIF 401 R
Measuring standard* Coefficient of linear expansion	SUPRADUR phase grating on Zerodur glass ceramic or glass; grating period: 8 μm $\alpha_{\text{therm}} = (0 \pm 0.1) \cdot 10^{-6} \text{ K}^{-1}$ (Zerodur glass ceramic) $\alpha_{\text{therm}} \approx 8 \cdot 10^{-6} \text{ K}^{-1}$ (glass)
Accuracy grade*	±1 μm (only for Zerodur glass ceramic up to a measuring length of 1020 mm), ±3 μm
Baseline error	≤ ±0.225 μm/5 mm
Measuring length (ML)* in mm	70 120 170 220 270 320 370 420 470 520 570 620 670 720 770 820 870 920 970 1020 1140 1240 1340 1440 1540 1640
Reference marks	One at midpoint of measuring length
Mass	0.8 g + 0.08 g/mm of measuring length

Scanning head	LIF 48	LIF 47				
Interface	~ 1 V _{PP}	□ TTL				
Integrated interpolation* Signal period	– 4 μm	5-fold 0.8 μm	10-fold 0.4 μm	20-fold 0.2 μm	50-fold 0.08 μm	100-fold 0.04 μm
Cutoff frequency –3 dB	≥ 1 MHz	–				
Scanning frequency*	–	≤ 500 kHz ≤ 250 kHz ≤ 125 kHz	≤ 250 kHz ≤ 125 kHz ≤ 62.5 kHz	≤ 250 kHz ≤ 125 kHz ≤ 62.5 kHz	≤ 100 kHz ≤ 50 kHz ≤ 25 kHz	≤ 50 kHz ≤ 25 kHz ≤ 12.5 kHz
Edge separation <i>a</i>	–	≥ 0.080 μs ≥ 0.175 μs ≥ 0.370 μs	≥ 0.080 μs ≥ 0.175 μs ≥ 0.370 μs	≥ 0.040 μs ≥ 0.080 μs ≥ 0.175 μs	≥ 0.040 μs ≥ 0.080 μs ≥ 0.175 μs	≥ 0.040 μs ≥ 0.080 μs ≥ 0.175 μs
Traversing speed¹⁾	≤ 240 m/min	≤ 120 m/min ≤ 60 m/min ≤ 30 m/min	≤ 60 m/min ≤ 30 m/min ≤ 15 m/min	≤ 60 m/min ≤ 30 m/min ≤ 15 m/min	≤ 24 m/min ≤ 12 m/min ≤ 6 m/min	≤ 12 m/min ≤ 6 m/min ≤ 3 m/min
Interpolation error RMS position noise	±12 nm 0.6 nm (1 MHz ²⁾)	–				
Electrical connection*	Cable (0.5 m/1 m/3 m) with 15-pin D-sub connector (male); interface electronics in the connector					
Cable length	See interface description; however, <i>incremental</i> : ≤ 30 m; <i>homing, limit</i> : ≤ 10 m; (with HEIDENHAIN cable)					
Supply voltage	DC 5 V ±0.25 V					
Power consumption (max.)	Scanning head: 130 mW; LIF 48 connector: 640 mW; LIF 47 connector: 720 mW (without load)					
Current consumption	< 150 mA	< 165 mA (without load)				
Vibration 55 Hz to 2000 Hz Shock 11 ms	≤ 400 m/s ² (EN 60068-2-6) ≤ 500 m/s ² (EN 60068-2-27)					
Operating temperature	0 °C to 50 °C					
Mass	Scanning head*	For scale made of Zerodur glass ceramic: 25 g For scale made of glass: 9 g				
	Cable	38 g/m				
	Connector	75 g				

* Please select when ordering

¹⁾ With TTL: maximum traversing speed during referencing: 9.6 m/min (40 kHz)

²⁾ –3 dB cutoff frequency of the subsequent electronics

LIDA 473, LIDA 483

Incremental linear encoders with limit switches

- For measuring steps of down to 10 nm
- Glass or glass ceramic measuring standard
- Measuring standard secured with adhesive film
- Consisting of a linear scale and scanning head

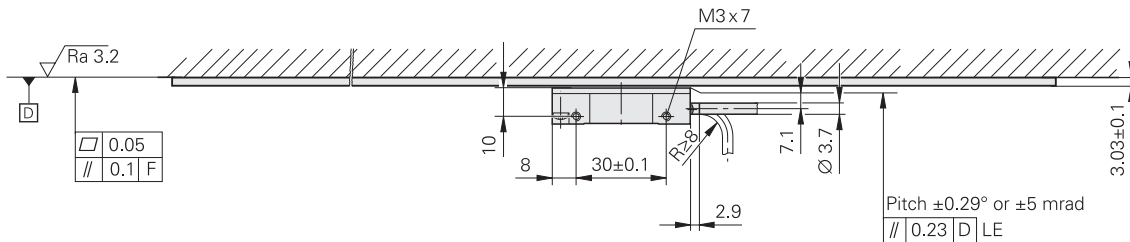
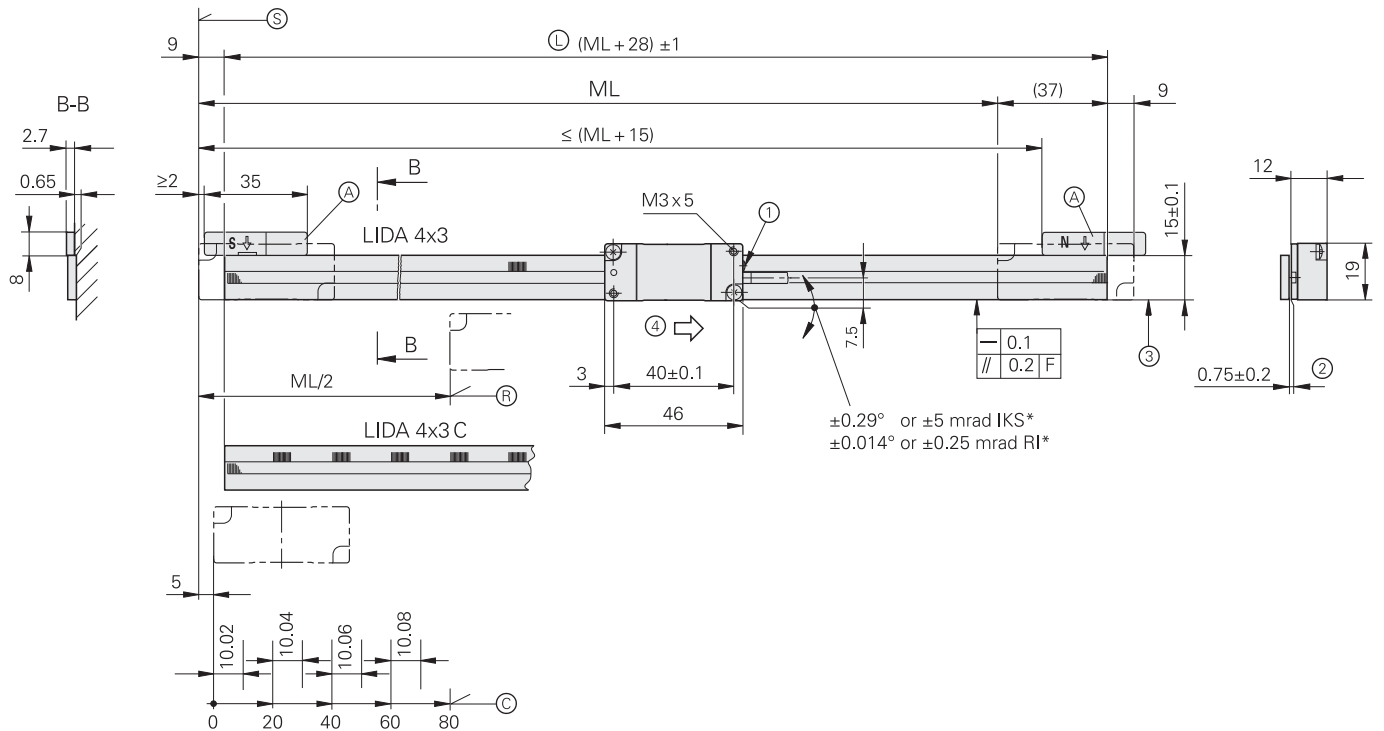

Mounting options for scanning head

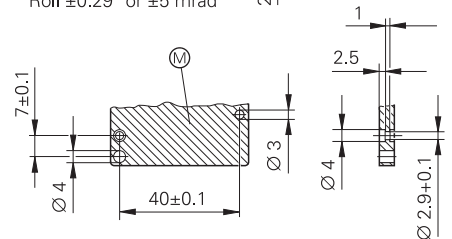
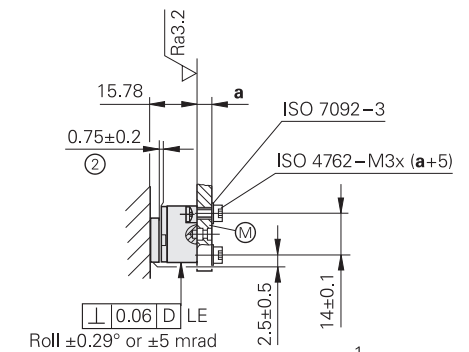
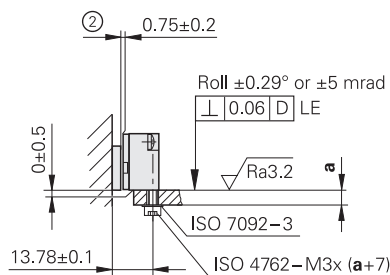
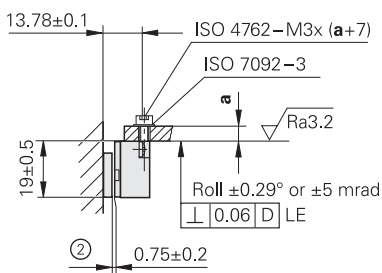

mm

 Tolerancing ISO 8015
 ISO 2768 - m H
 < 6 mm: ±0.2 mm

F = Machine guideway
 * = Max. change during operation
 (IKS: incremental track, RI: Reference mark track)

- Ⓢ = Beginning of measuring length (ML)
- Ⓡ = Reference-mark position on LIDA 4x3
- Ⓢ = Reference-mark position on LIDA 4x3C
- Ⓢ = Scale length
- Ⓐ = Selector magnet for limit switch
- Ⓜ = Mounting surface for scanning head
- 1 = Signal-quality indicator
- 2 = Scanning gap
- 3 = Scale stop surface
- 4 = Direction of motion of the scanning unit for ascending position values



Scale	LIDA 403
Measuring standard Coefficient of linear expansion*	METALLUR scale grating on glass or glass ceramic; grating period: 20 µm $\alpha_{\text{therm}} \approx 8 \cdot 10^{-6} \text{ K}^{-1}$ (glass) $\alpha_{\text{therm}} = (0 \pm 0.5) \cdot 10^{-6} \text{ K}^{-1}$ (Robax glass ceramic)
Accuracy grade*	±1 µm (only for Robax glass ceramic), ±3 µm, ±5 µm
Baseline error	≤ ±0.275 µm/10 mm
Measuring length (ML)* in mm	240 340 440 640 840 1040 1240 1440 1640 1840 2040 2240 2440 2640 2840 3040 (Robax glass ceramic only up to ML of 1640)
Reference marks*	LIDA 4x3: one at midpoint of measuring length; LIDA 4x3C: distance-coded
Mass	3 g + 0.11 g/mm of measuring length

Scanning head	LIDA 48	LIDA 47			
Interface	~ 1 V _{PP}	□□TTL			
Integrated interpolation* Signal period	– 20 µm	5-fold 4 µm	10-fold 2 µm	50-fold 0.4 µm	100-fold 0.2 µm
Cutoff frequency –3 dB	≥ 500 kHz	–			
Scanning frequency*	–	≤ 400 kHz ≤ 200 kHz ≤ 100 kHz ≤ 50 kHz	≤ 200 kHz ≤ 100 kHz ≤ 50 kHz ≤ 25 kHz	≤ 50 kHz ≤ 25 kHz ≤ 12,5 kHz	≤ 25 kHz ≤ 12.5 kHz ≤ 6.25 kHz
Edge separation a ¹⁾	–	≥ 0.100 µs ≥ 0.220 µs ≥ 0.465 µs ≥ 0.950 µs	≥ 0.100 µs ≥ 0.220 µs ≥ 0.465 µs ≥ 0.950 µs	≥ 0.080 µs ≥ 0.175 µs ≥ 0.370 µs	≥ 0.080 µs ≥ 0.175 µs ≥ 0.370 µs
Traversing speed ¹⁾	≤ 600 m/min	≤ 480 m/min ≤ 240 m/min ≤ 120 m/min ≤ 60 m/min	≤ 240 m/min ≤ 120 m/min ≤ 60 m/min ≤ 30 m/min	≤ 60 m/min ≤ 30 m/min ≤ 15 m/min	≤ 30 m/min ≤ 15 m/min ≤ 7.5 m/min
Interpolation error	±45 nm	–			
Limit switches	L1/L2 with two different magnets; <i>output signals</i> : TTL (without line driver)				
Electrical connection	Cable (0.5 m/1 m/3 m) with 15-pin D-sub connector (male)				
Cable length	See interface description; however, <i>limit</i> : ≤ 20 m (with HEIDENHAIN cable)				
Supply voltage	DC 5 V ±0.5 V				
Current consumption	< 130 mA	< 150 mA (without load)			
Vibration 55 Hz to 2000 Hz Shock 6 ms	≤ 500 m/s ² (EN 60068-2-6) ≤ 1000 m/s ² (EN 60068-2-27)				
Operating temperature	–10 °C to 70 °C				
Mass	Scanning head Cable Connector	20 g (without cable) 22 g/m 32 g			

* Please select when ordering

¹⁾ At a corresponding cutoff or scanning frequency

Robax is a registered trademark of Schott-Glaswerke, Mainz, Germany

LIDA 475, LIDA 485

Incremental linear encoders for measuring lengths of up to 30 m

- For measuring steps of down to 10 nm
- Limit switches
- Steel scale tape pulled through aluminum extrusions and tensioned
- Consisting of a linear scale and scanning head

ML ≤ 2040

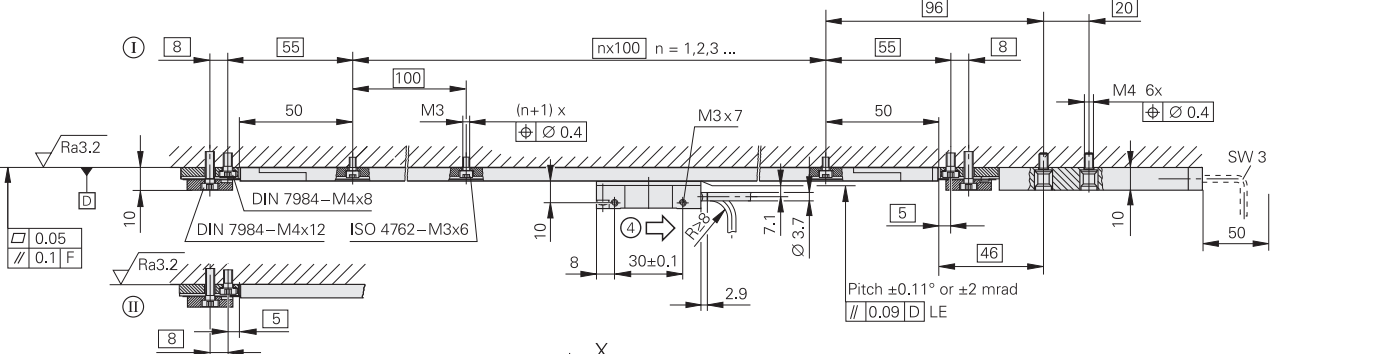
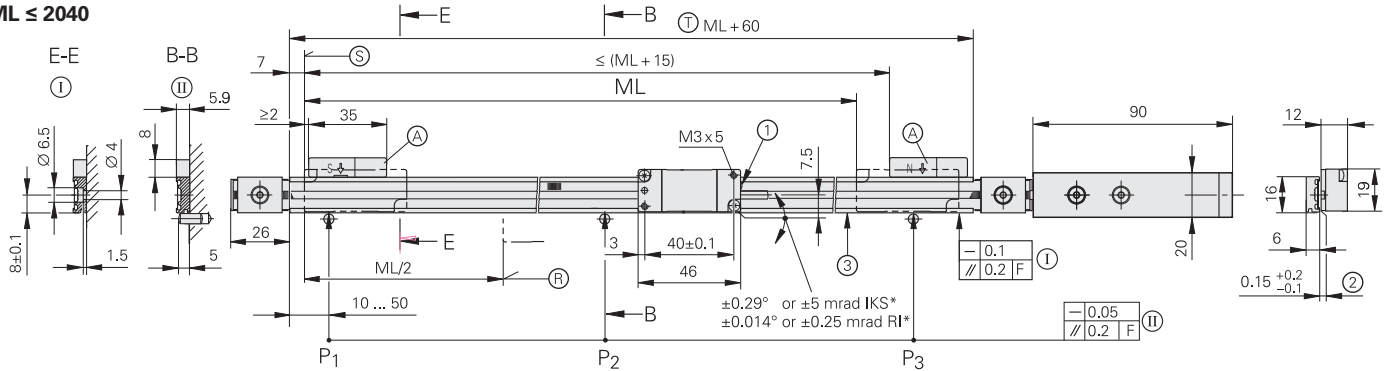

ML > 2040 (e.g., 5040)

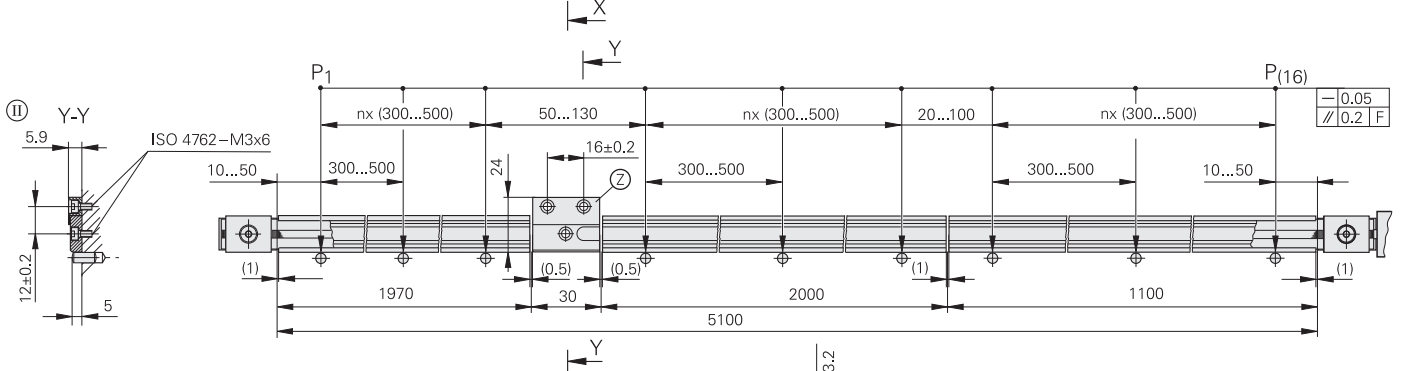
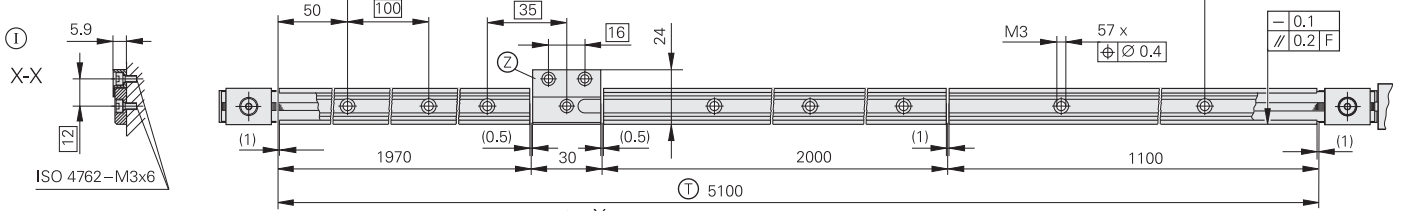

Mounting options for scanning head

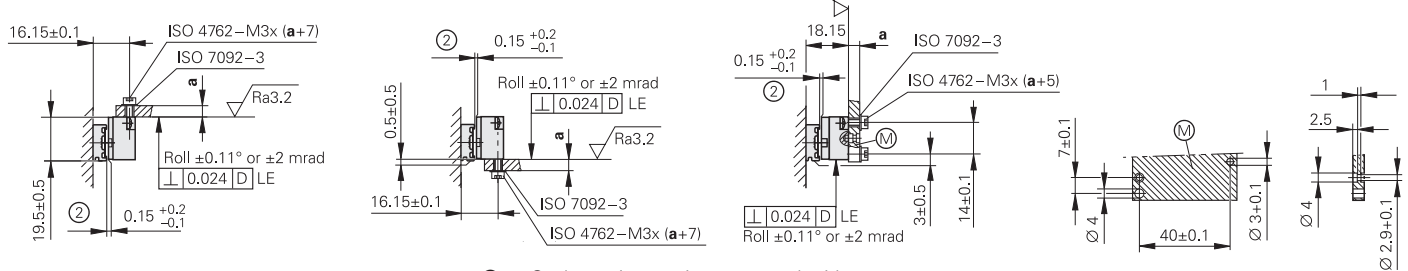

mm

 Tolerancing ISO 8015
 ISO 2768 - m H
 < 6 mm: ±0.2 mm

- ⊙ = Scale carrier sections secured with screws
- ⊕ = Scale carrier sections secured with PRECIMET
- F = Machine guideway
- * = Max. change during operation (IKS: incremental track, RI: Reference mark track)
- P = Measuring points for alignment
- ⊙ = Beginning of measuring length (ML)
- ⊕ = Reference mark position

- ⊕ = Selector magnet for limit switch
- ⊕ = Carrier length
- ⊕ = Spacer for measuring lengths of 3040 mm or greater
- ⊕ = Mounting surface for scanning head
- 1 = Signal-quality indicator
- 2 = Scanning gap
- 3 = Carrier stop surface
- 4 = Direction of motion of the scanning unit for ascending position values



Scale	LIDA 405
Measuring standard	Steel scale tape with METALLUR scale grating; grating period: 20 µm
Coefficient of linear expansion	Depends on the mounting surface
Accuracy grade	±5 µm
Baseline error	≤ ±0.750 µm/50 mm (typical)
Measuring length (ML)* in mm	140 240 340 440 540 640 740 840 940 1040 1140 1240 1340 1440 1540 1640 1740 1840 1940 2040
	Greater measuring lengths (up to 30040 mm) with a one-piece scale tape and individual scale carrier sections
Reference marks	One at midpoint of measuring length
Mass	115 g + 0.25 g/mm of measuring length

Scanning head	LIDA 48	LIDA 47			
Interface	~ 1 V _{PP}	□TTL			
Integrated interpolation* Signal period	– 20 µm	5-fold 4 µm	10-fold 2 µm	50-fold 0.4 µm	100-fold 0.2 µm
Cutoff frequency –3 dB	≥ 500 kHz	–			
Scanning frequency*	–	≤ 400 kHz ≤ 200 kHz ≤ 100 kHz ≤ 50 kHz	≤ 200 kHz ≤ 100 kHz ≤ 50 kHz ≤ 25 kHz	≤ 50 kHz ≤ 25 kHz ≤ 12.5 kHz	≤ 25 kHz ≤ 12.5 kHz ≤ 6.25 kHz
Edge separation a ¹⁾	–	≥ 0.100 µs ≥ 0.220 µs ≥ 0.465 µs ≥ 0.950 µs	≥ 0.100 µs ≥ 0.220 µs ≥ 0.465 µs ≥ 0.950 µs	≥ 0.080 µs ≥ 0.175 µs ≥ 0.370 µs	≥ 0.080 µs ≥ 0.175 µs ≥ 0.370 µs
Traversing speed ¹⁾	≤ 600 m/min	≤ 480 m/min ≤ 240 m/min ≤ 120 m/min ≤ 60 m/min	≤ 240 m/min ≤ 120 m/min ≤ 60 m/min ≤ 30 m/min	≤ 60 m/min ≤ 30 m/min ≤ 15 m/min	≤ 30 m/min ≤ 15 m/min ≤ 7.5 m/min
Interpolation error	±45 nm	–			
Limit switches	L1/L2 with two different magnets; <i>output signals</i> : TTL (without line driver)				
Electrical connection	Cable (0.5 m/1 m/3 m) with 15-pin D-sub connector (male)				
Cable length	See interface description; however, <i>limit</i> : ≤ 20 m (with HEIDENHAIN cable)				
Supply voltage	DC 5 V ±0.5 V				
Current consumption	< 130 mA	< 150 mA (without load)			
Vibration 55 Hz to 2000 Hz Shock 6 ms	≤ 500 m/s ² (EN 60068-2-6) ≤ 1000 m/s ² (EN 60068-2-27)				
Operating temperature	–10 °C to 70 °C				
Mass	Scanning head Cable Connector	20 g (without cable) 22 g/m 32 g			

* Please select when ordering

¹⁾ At a corresponding cutoff or scanning frequency

LIDA 477, LIDA 487

Incremental linear encoders for measuring ranges of up to 6 m

- For measuring steps of down to 10 nm
- Limit switches
- Steel scale tape pulled through adhesive aluminum extrusions and secured at center
- Consisting of a linear scale and scanning head

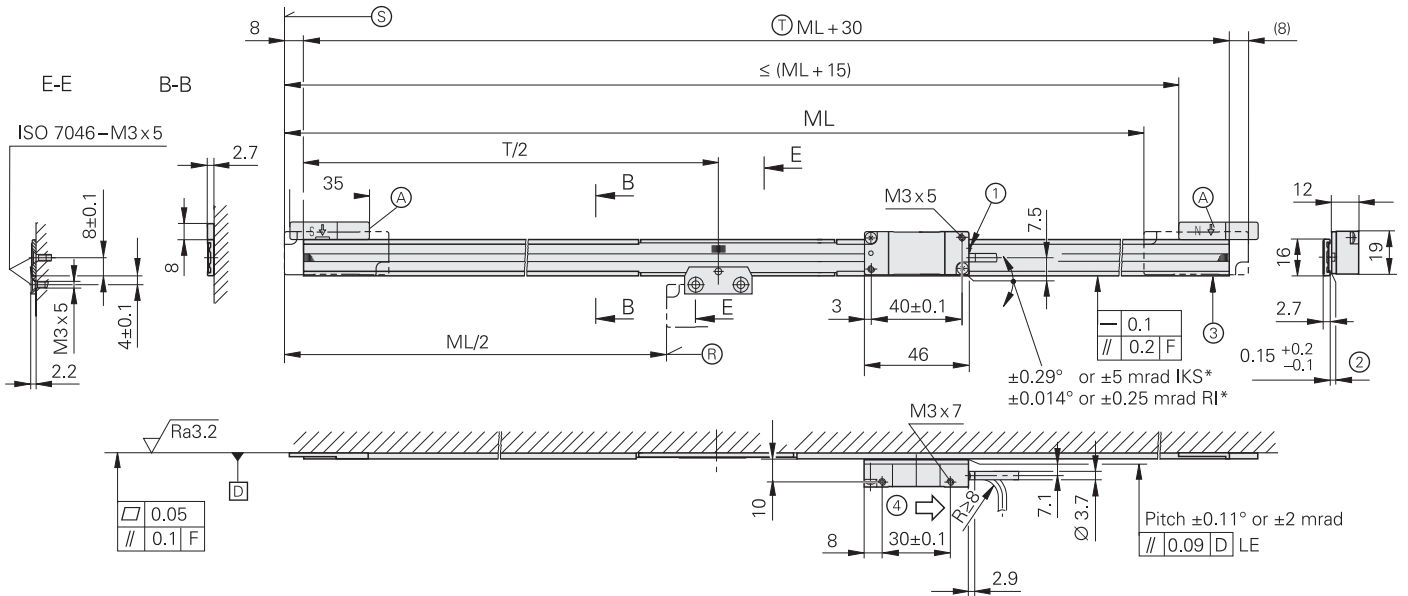

ML ≤ 2040
(e.g., 840)

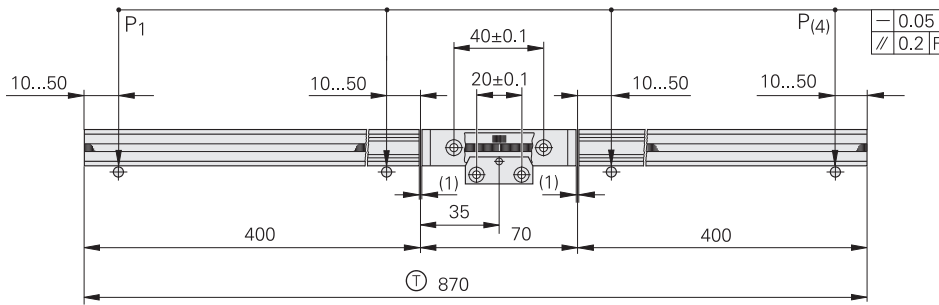

ML > 2040
(e.g., 5040)

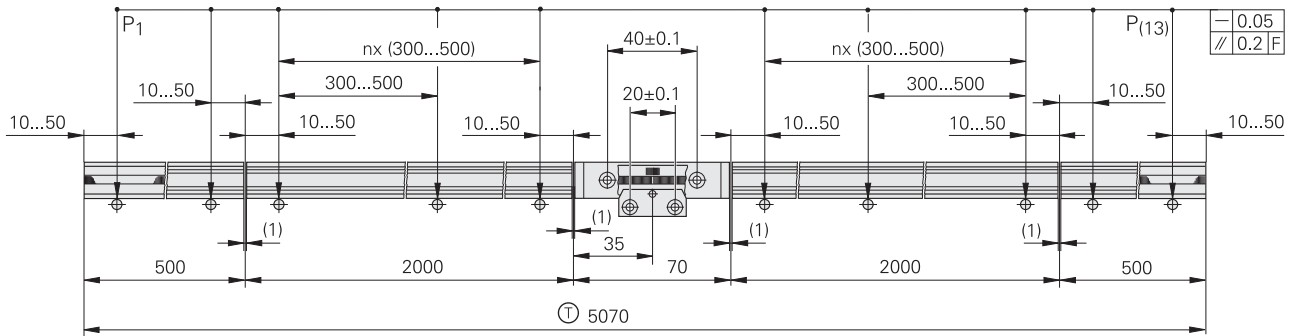

Mounting options for scanning head

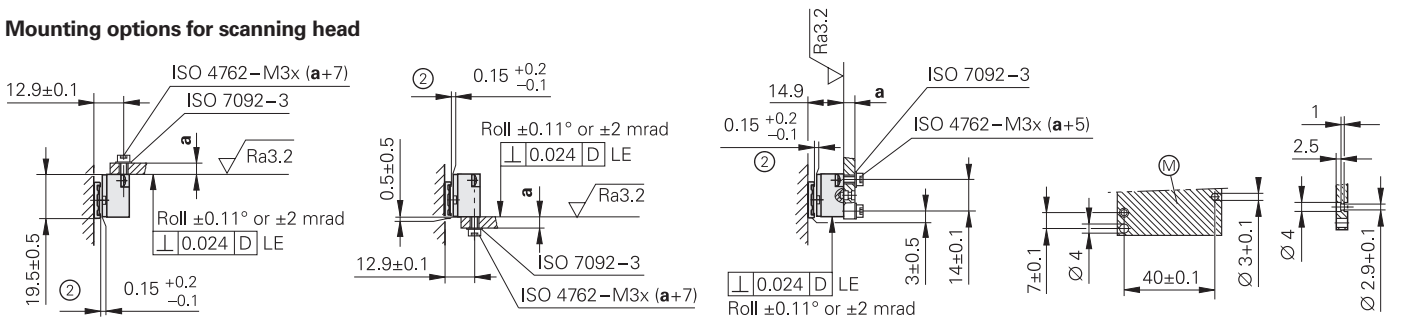

mm
Tolerancing ISO 8015
ISO 2768 - m H
< 6 mm: ±0.2 mm

- F = Machine guideway
- * = Max. change during operation (IKS: incremental track, RI: Reference mark track)
- P = Measuring points for alignment
- Ⓢ = Beginning of measuring length (ML)
- Ⓡ = Reference mark position
- Ⓐ = Selector magnet for limit switch
- Ⓣ = Carrier length
- Ⓜ = Mounting surface for scanning head
- 1 = Signal-quality indicator
- 2 = Scanning gap
- 3 = Carrier stop surface
- 4 = Direction of motion of the scanning unit for ascending position values



Scale	LIDA 407
Measuring standard	Steel scale tape with METALLUR scale grating; grating period: 20 µm
Coefficient of linear expansion	$\alpha_{\text{therm}} \approx 10 \cdot 10^{-6} \text{ K}^{-1}$
Accuracy grade*	$\pm 3 \text{ µm}$ (up to ML 1040); $\pm 5 \text{ µm}$ (for ML 1240 or greater); $\pm 15 \text{ µm}^{1)}$
Baseline error	$\leq \pm 0.750 \text{ µm}/50 \text{ mm}$ (typical)
Measuring length (ML)* in mm	240 440 640 840 1040 1240 1440 1640 1840 2040 2240 2440 2640 2840 3040 3240 3440 3640 3840 4040 4240 4440 4640 4840 5040 5240 5440 5640 5840 6040
Reference marks	One at midpoint of measuring length
Mass	25 g + 0.1 g/mm of measuring length

Scanning head	LIDA 48	LIDA 47			
Interface	$\sim 1 \text{ V}_{\text{PP}}$	TTL			
Integrated interpolation* Signal period	– 20 µm	5-fold 4 µm	10-fold 2 µm	50-fold 0.4 µm	100-fold 0.2 µm
Cutoff frequency –3 dB	$\geq 500 \text{ kHz}$	–			
Scanning frequency*	–	$\leq 400 \text{ kHz}$ $\leq 200 \text{ kHz}$ $\leq 100 \text{ kHz}$ $\leq 50 \text{ kHz}$	$\leq 200 \text{ kHz}$ $\leq 100 \text{ kHz}$ $\leq 50 \text{ kHz}$ $\leq 25 \text{ kHz}$	$\leq 50 \text{ kHz}$ $\leq 25 \text{ kHz}$ $\leq 12.5 \text{ kHz}$	$\leq 25 \text{ kHz}$ $\leq 12.5 \text{ kHz}$ $\leq 6.25 \text{ kHz}$
Edge separation $a^{2)}$	–	$\geq 0.100 \text{ µs}$ $\geq 0.220 \text{ µs}$ $\geq 0.465 \text{ µs}$ $\geq 0.950 \text{ µs}$	$\geq 0.100 \text{ µs}$ $\geq 0.220 \text{ µs}$ $\geq 0.465 \text{ µs}$ $\geq 0.950 \text{ µs}$	$\geq 0.080 \text{ µs}$ $\geq 0.175 \text{ µs}$ $\geq 0.370 \text{ µs}$	$\geq 0.080 \text{ µs}$ $\geq 0.175 \text{ µs}$ $\geq 0.370 \text{ µs}$
Traversing speed²⁾	$\leq 600 \text{ m/min}$	$\leq 480 \text{ m/min}$ $\leq 240 \text{ m/min}$ $\leq 120 \text{ m/min}$ $\leq 60 \text{ m/min}$	$\leq 240 \text{ m/min}$ $\leq 120 \text{ m/min}$ $\leq 60 \text{ m/min}$ $\leq 30 \text{ m/min}$	$\leq 60 \text{ m/min}$ $\leq 30 \text{ m/min}$ $\leq 15 \text{ m/min}$	$\leq 30 \text{ m/min}$ $\leq 15 \text{ m/min}$ $\leq 7.5 \text{ m/min}$
Interpolation error	$\pm 45 \text{ nm}$	–			
Limit switches	L1/L2 with two different magnets; <i>output signals</i> : TTL (without line driver)				
Electrical connection	Cable (0.5 m/1 m/3 m) with 15-pin D-sub connector (male)				
Cable length	See interface description; however, <i>limit</i> : $\leq 20 \text{ m}$ (with HEIDENHAIN cable)				
Supply voltage	DC 5 V $\pm 0.5 \text{ V}$				
Current consumption	$< 130 \text{ mA}$	$< 150 \text{ mA}$ (without load)			
Vibration 55 Hz to 2000 Hz Shock 6 ms	$\leq 500 \text{ m/s}^2$ (EN 60068-2-6) $\leq 1000 \text{ m/s}^2$ (EN 60068-2-27)				
Operating temperature	-10 °C to 70 °C				
Mass	Scanning head	20 g (without cable)			
	Cable	22 g/m			
	Connector	32 g			

* Please select when ordering

¹⁾ $\pm 5 \text{ µm}$ after linear length-error compensation in the subsequent electronics

²⁾ At a corresponding cutoff or scanning frequency

LIDA 479, LIDA 489

Incremental linear encoders for measuring ranges of up to 6 m

- For measuring steps of down to 10 nm
- Limit switches
- Steel scale tape adhesively bonded to mounting surface
- Consisting of a scale tape and scanning head

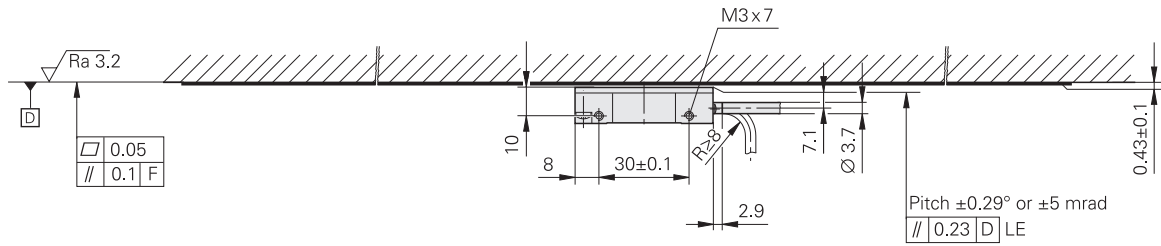
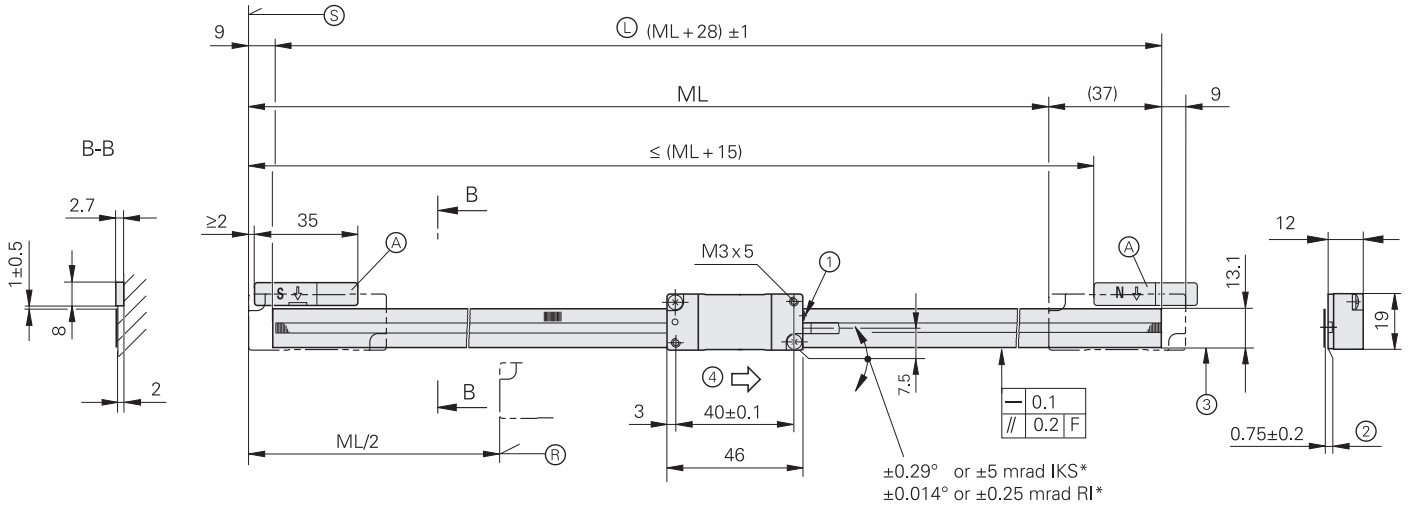

Mounting options for scanning head

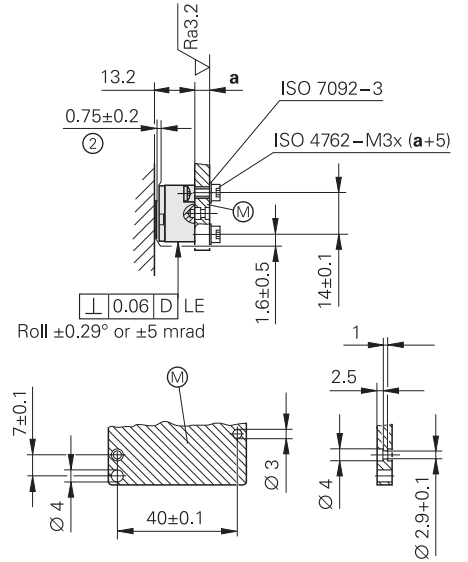
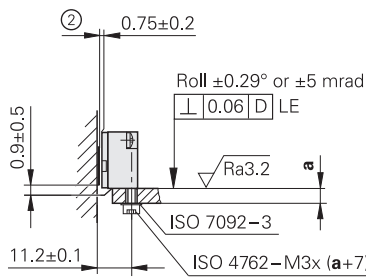
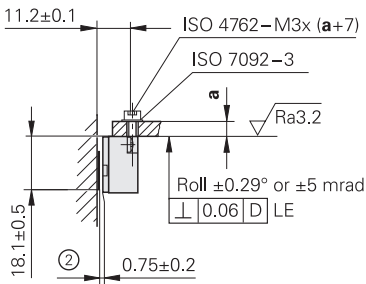

mm

 Tolerancing ISO 8015
 ISO 2768 - m H
 < 6 mm: ±0.2 mm

F = Machine guideway
 * = Max. change during operation
 (IKS: incremental track, RI: Reference mark track)

- Ⓢ = Beginning of measuring length (ML)
- Ⓡ = Reference mark position
- Ⓛ = Scale tape length
- Ⓐ = Selector magnet for limit switch
- Ⓜ = Mounting surface for scanning head
- 1 = Signal-quality indicator
- 2 = Scanning gap
- 3 = Scale-tape stop surface
- 4 = Direction of motion of the scanning unit for ascending position values



Scale	LIDA 409	
Measuring standard	Steel scale tape with METALLUR scale grating; grating period: 20 µm	
Coefficient of linear expansion	$\alpha_{\text{therm}} \approx 10 \cdot 10^{-6} \text{ K}^{-1}$	
Accuracy grade*	$\pm 3 \text{ µm}, \pm 15 \text{ µm}^{1)}$	
Baseline error	$\leq \pm 0.750 \text{ µm}/50 \text{ mm}$ (typical)	
Measuring length (ML)* in mm	70 120 170 220 270 320 370 420 520 620 720 820 920 1020	Scale tape from the roll: 2 m, 4 m, 6 m
Reference marks	One at midpoint of measuring length	Every 50 mm ³⁾
Mass	31 g/m	

Scanning head	LIDA 48	LIDA 47			
Interface	$\sim 1 \text{ V}_{\text{PP}}$	□□TTL			
Integrated interpolation* Signal period	– 20 µm	5-fold 4 µm	10-fold 2 µm	50-fold 0.4 µm	100-fold 0.2 µm
Cutoff frequency –3 dB	$\geq 500 \text{ kHz}$	–			
Scanning frequency*	–	$\leq 400 \text{ kHz}$ $\leq 200 \text{ kHz}$ $\leq 100 \text{ kHz}$ $\leq 50 \text{ kHz}$	$\leq 200 \text{ kHz}$ $\leq 100 \text{ kHz}$ $\leq 50 \text{ kHz}$ $\leq 25 \text{ kHz}$	$\leq 50 \text{ kHz}$ $\leq 25 \text{ kHz}$ $\leq 12.5 \text{ kHz}$	$\leq 25 \text{ kHz}$ $\leq 12.5 \text{ kHz}$ $\leq 6.25 \text{ kHz}$
Edge separation $a^{2)}$	–	$\geq 0.100 \text{ µs}$ $\geq 0.220 \text{ µs}$ $\geq 0.465 \text{ µs}$ $\geq 0.950 \text{ µs}$	$\geq 0.100 \text{ µs}$ $\geq 0.220 \text{ µs}$ $\geq 0.465 \text{ µs}$ $\geq 0.950 \text{ µs}$	$\geq 0.080 \text{ µs}$ $\geq 0.175 \text{ µs}$ $\geq 0.370 \text{ µs}$	$\geq 0.080 \text{ µs}$ $\geq 0.175 \text{ µs}$ $\geq 0.370 \text{ µs}$
Traversing speed²⁾	$\leq 600 \text{ m/min}$	$\leq 480 \text{ m/min}$ $\leq 240 \text{ m/min}$ $\leq 120 \text{ m/min}$ $\leq 60 \text{ m/min}$	$\leq 240 \text{ m/min}$ $\leq 120 \text{ m/min}$ $\leq 60 \text{ m/min}$ $\leq 30 \text{ m/min}$	$\leq 60 \text{ m/min}$ $\leq 30 \text{ m/min}$ $\leq 15 \text{ m/min}$	$\leq 30 \text{ m/min}$ $\leq 15 \text{ m/min}$ $\leq 7.5 \text{ m/min}$
Interpolation error	$\pm 45 \text{ nm}$	–			
Limit switches	L1/L2 with two different magnets; <i>output signals</i> : TTL (without line driver)				
Electrical connection	Cable (0.5 m/1 m/3 m) with 15-pin D-sub connector (male)				
Cable length	See interface description; however, <i>limit</i> : $\leq 20 \text{ m}$ (with HEIDENHAIN cable)				
Supply voltage	DC 5 V $\pm 0.5 \text{ V}$				
Current consumption	$< 130 \text{ mA}$	$< 150 \text{ mA}$ (without load)			
Vibration 55 Hz to 2000 Hz Shock 6 ms	$\leq 500 \text{ m/s}^2$ (EN 60068-2-6) $\leq 1000 \text{ m/s}^2$ (EN 60068-2-27)				
Operating temperature	-10 °C to 70 °C				
Mass	Scanning head Cable Connector	20 g (without cable) 22 g/m 32 g			

* Please select when ordering

¹⁾ $\pm 5 \text{ µm}$ after linear length-error compensation in the subsequent electronics

²⁾ At a corresponding cutoff or scanning frequency

³⁾ Only one reference mark may be used during operation. *Recommended*: use the LIDA 4xR special scanning head

LIDA 277, LIDA 287

Incremental linear encoder with wide mounting tolerances

- For measuring steps of down to 100 nm
- Scale tape cut from roll
- Steel scale tape pulled through adhesive aluminum extrusions and secured
- Integrated three-color LED signal-quality indicator
- Consisting of a linear scale and scanning head

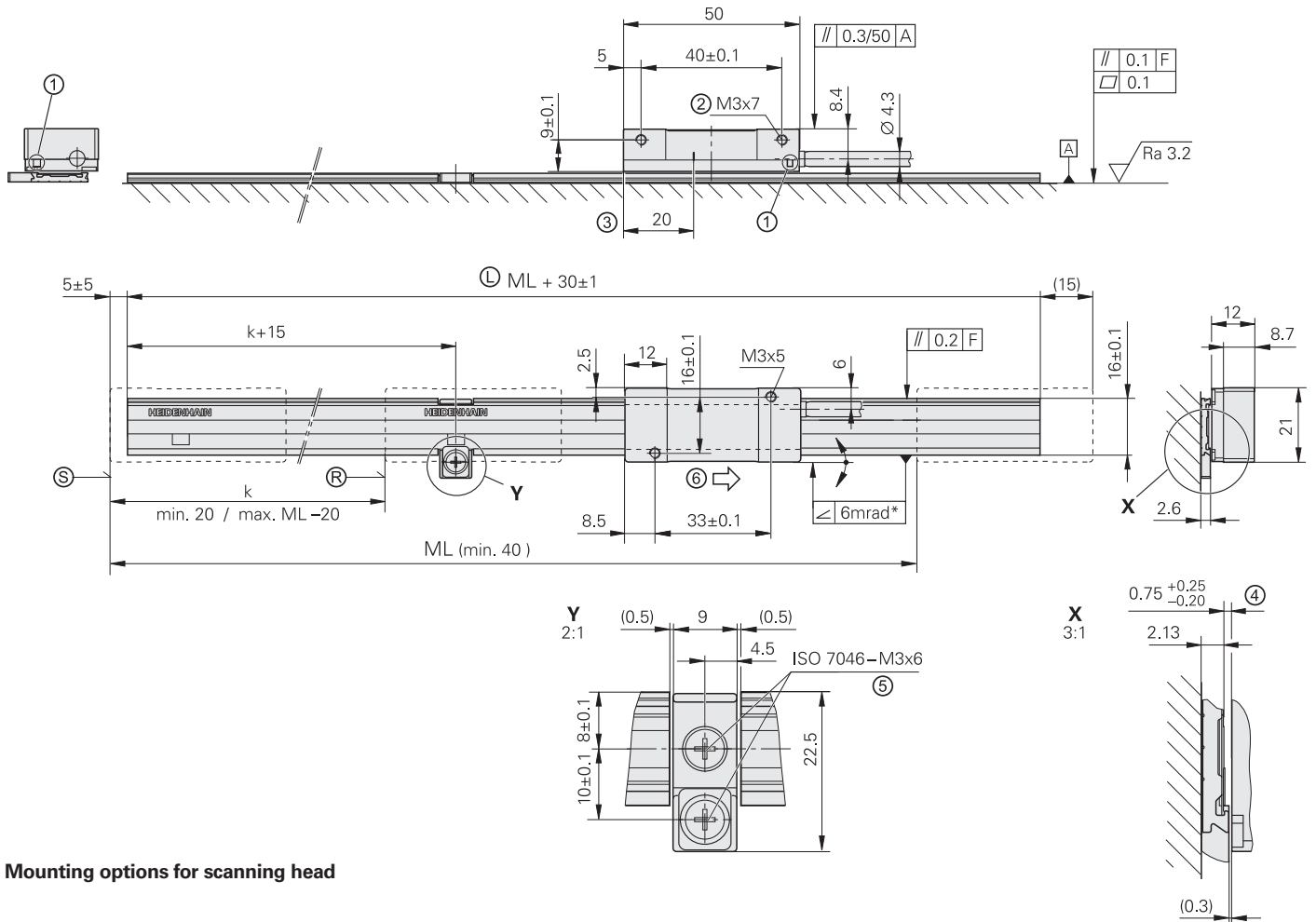

Mounting options for scanning head

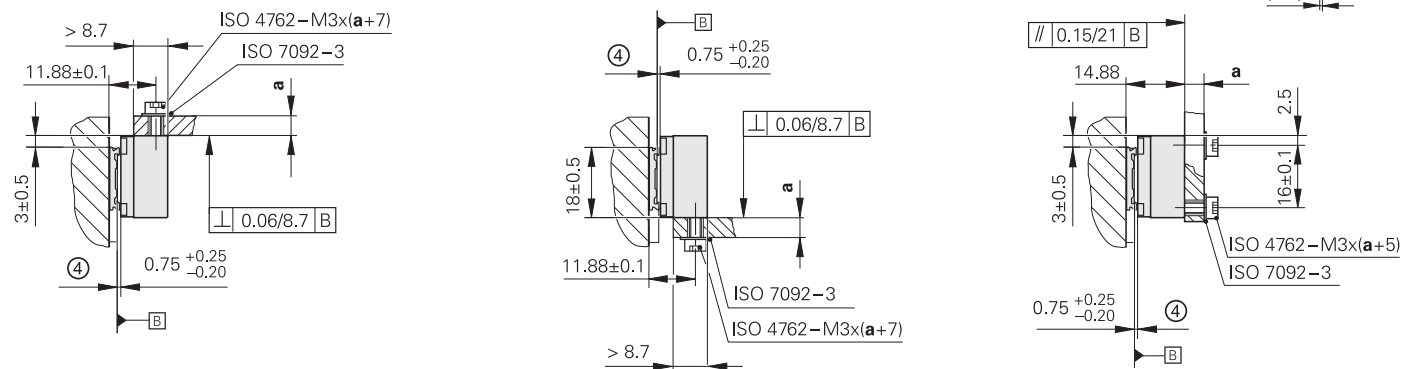

mm

 Tolerancing ISO 8015
 ISO 2768 - m H
 < 6 mm: ±0.2 mm

- * = Maximum change during operation
- F = Machine guideway
- Ⓜ = Reference mark
- Ⓛ = Scale tape length
- Ⓢ = Beginning of measuring length (ML)
- 1 = LED (integrated mounting checker)
- 2 = Thread at both ends
- 3 = Position of reference mark relative to scanning head
- 4 = Mounting clearance between scale tape and scanning head
- 5 = M3 threaded mating hole; depth: 5 mm
- 6 = Direction of motion of the scanning unit for ascending position values

Reference mark:

k = Any position of the selected reference mark starting from the beginning of the measuring length (depending on the cut)



Scale	LIDA 207
Measuring standard Coefficient of linear expansion	Steel scale tape; grating period: 200 µm $\alpha_{\text{therm}} \approx 10 \cdot 10^{-6} \text{ K}^{-1}$
Accuracy grade	±15 µm
Scale tape from roll*	3 m, 5 m, 10 m
Reference marks	Selectable every 100 mm
Mass	Scale tape Scale tape carrier
	20 g/m 70 g/m

Scanning head	LIDA 28	LIDA 27		
Interface	~ 1 V _{pp}	□ TTL		
Integrated Interpolation* Signal period	– 200 µm	10-fold 20 µm	50-fold 4 µm	100-fold 2 µm
Cut-off frequency Scanning frequency Edge separation <i>a</i>	≥ 50 kHz – –	– ≥ 50 kHz ≥ 0.465 µs	– ≤ 25 kHz ≥ 0.175 µs	– ≤ 12.5 kHz ≥ 0.175 µs
Traversing speed	≤ 600 m/min		≤ 300 m/min	≤ 150 m/min
Interpolation error	±2 µm	–		
Electrical connection*	Cable (1 m or 3 m) with 15-pin D-sub connector (male)			
Cable length	See the interface description; however, ≤ 30 m (with HEIDENHAIN cable)			
Supply voltage	DC 5 V ±0.25 V			
Current consumption	< 155 mA	< 140 mA (without load)		
Vibration 55 Hz to 2000 Hz Shock 11 ms	≤ 200 m/s ² (EN 60068-2-6) ≤ 500 m/s ² (EN 60068-2-27)			
Operating temperature	–10 °C to 70 °C			
Mass	Scanning head Cable Connector	20 g (without cable) 30 g/m 32 g		

* Please select when ordering

LIDA 279, LIDA 289

Incremental linear encoder with wide mounting tolerances

- For measuring steps of down to 100 nm
- Scale tape cut from roll
- Steel scale tape adhesively bonded to mounting surface
- Integrated three-color LED signal-quality indicator
- Consisting of a linear scale and scanning head

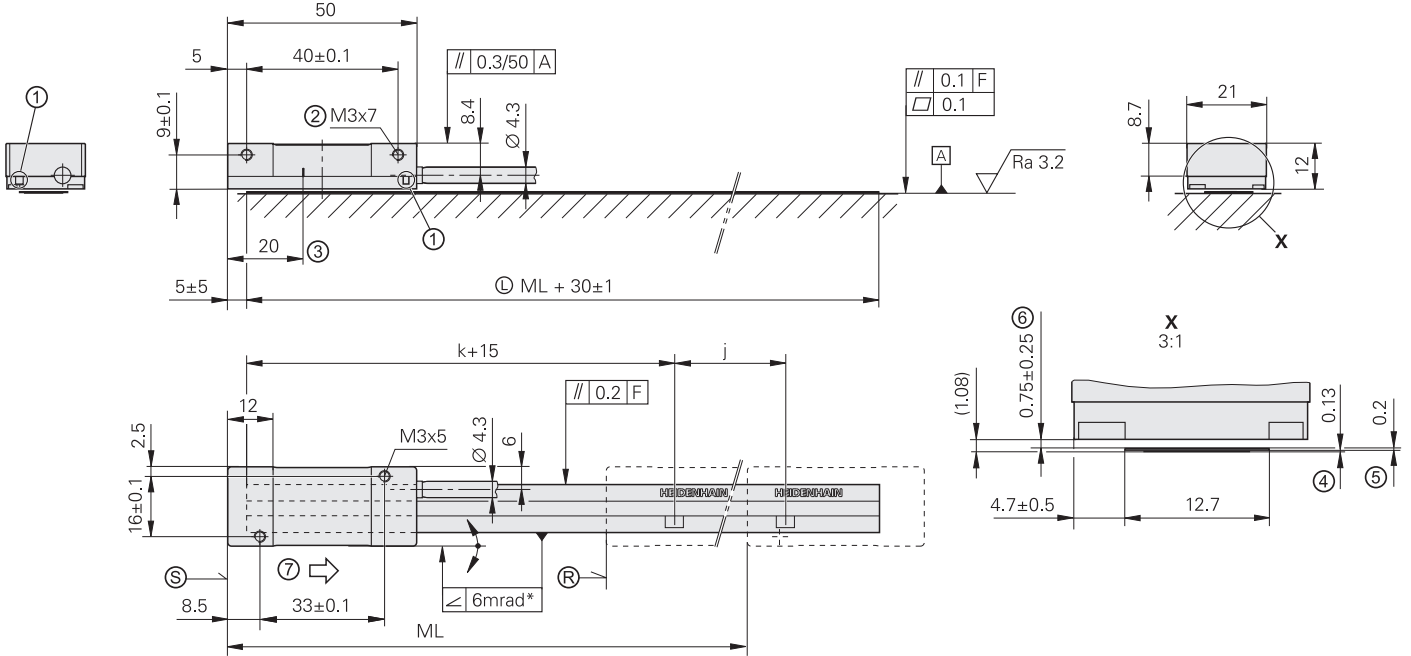

Mounting options for scanning head

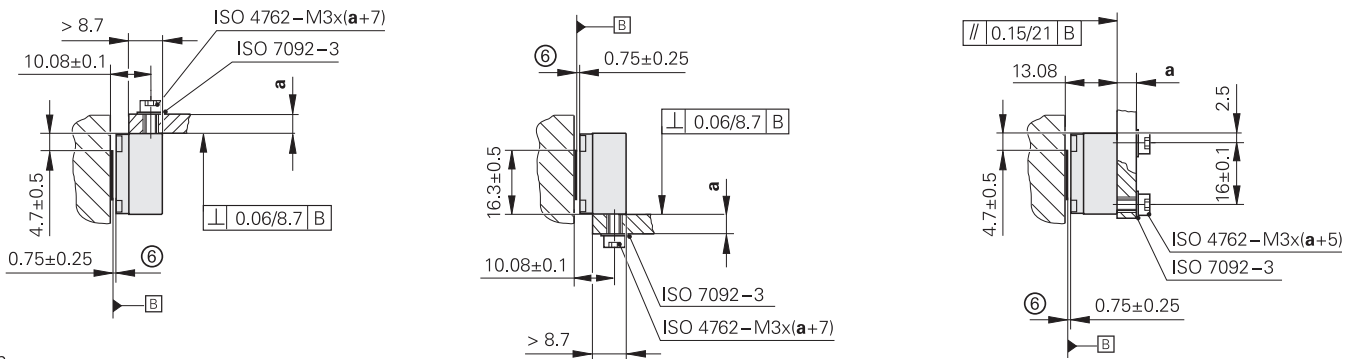

mm



Tolerancing ISO 8015

ISO 2768 - m H

< 6 mm: ±0.2 mm

- * = Maximum change during operation
- F = Machine guideway
- Ⓐ = Reference mark
- Ⓞ = Scale tape length
- Ⓢ = Beginning of measuring length (ML)
- 1 = LED (integrated mounting checker)
- 2 = Thread at both ends
- 3 = Position of reference mark relative to scanning head
- 4 = Adhesive tape
- 5 = Steel scale tape
- 6 = Mounting clearance between scale tape and scanning head
- 7 = Direction of motion of the scanning unit for ascending position values

Reference mark:

k = Any position of the selected reference mark starting from the beginning of the measuring length (depending on the cut)

j = Additional reference marks spaced every n x 100 mm



Scale	LIDA 209
Measuring standard Coefficient of linear expansion	Steel scale tape; grating period: 200 µm $\alpha_{\text{therm}} \approx 10 \cdot 10^{-6} \text{ K}^{-1}$
Accuracy grade	±15 µm
Scale tape from roll*	3 m, 5 m, 10 m
Reference marks	Selectable every 100 mm
Mass	20 g/m

Scanning head	LIDA 28	LIDA 27		
Interface	~ 1 V _{PP}	□□TTL		
Integrated Interpolation* Signal period	– 200 µm	10-fold 20 µm	50-fold 4 µm	100-fold 2 µm
Cut-off frequency Scanning frequency Edge separation <i>a</i>	≥ 50 kHz – –	– ≥ 50 kHz ≥ 0.465 µs	– ≤ 25 kHz ≥ 0.175 µs	– ≤ 12.5 kHz ≥ 0.175 µs
Traversing speed	≤ 600 m/min		≤ 300 m/min	≤ 150 m/min
Interpolation error	±2 µm	–		
Electrical connection*	Cable (1 m or 3 m) with 15-pin D-sub connector (male)			
Cable length	See the interface description; however, ≤ 30 m (with HEIDENHAIN cable)			
Supply voltage	DC 5 V ±0.25 V			
Current consumption	< 155 mA	< 140 mA (without load)		
Vibration 55 Hz to 2000 Hz Shock 11 ms	≤ 200 m/s ² (EN 60068-2-6) ≤ 500 m/s ² (EN 60068-2-27)			
Operating temperature	–10 °C to 70 °C			
Mass	Scanning head	20 g (without cable)		
	Cable	30 g/m		
	Connector	32 g		

* Please select when ordering

PP 281 R

Two-coordinate incremental encoder

- For measuring steps of 1 μm to 0.05 μm

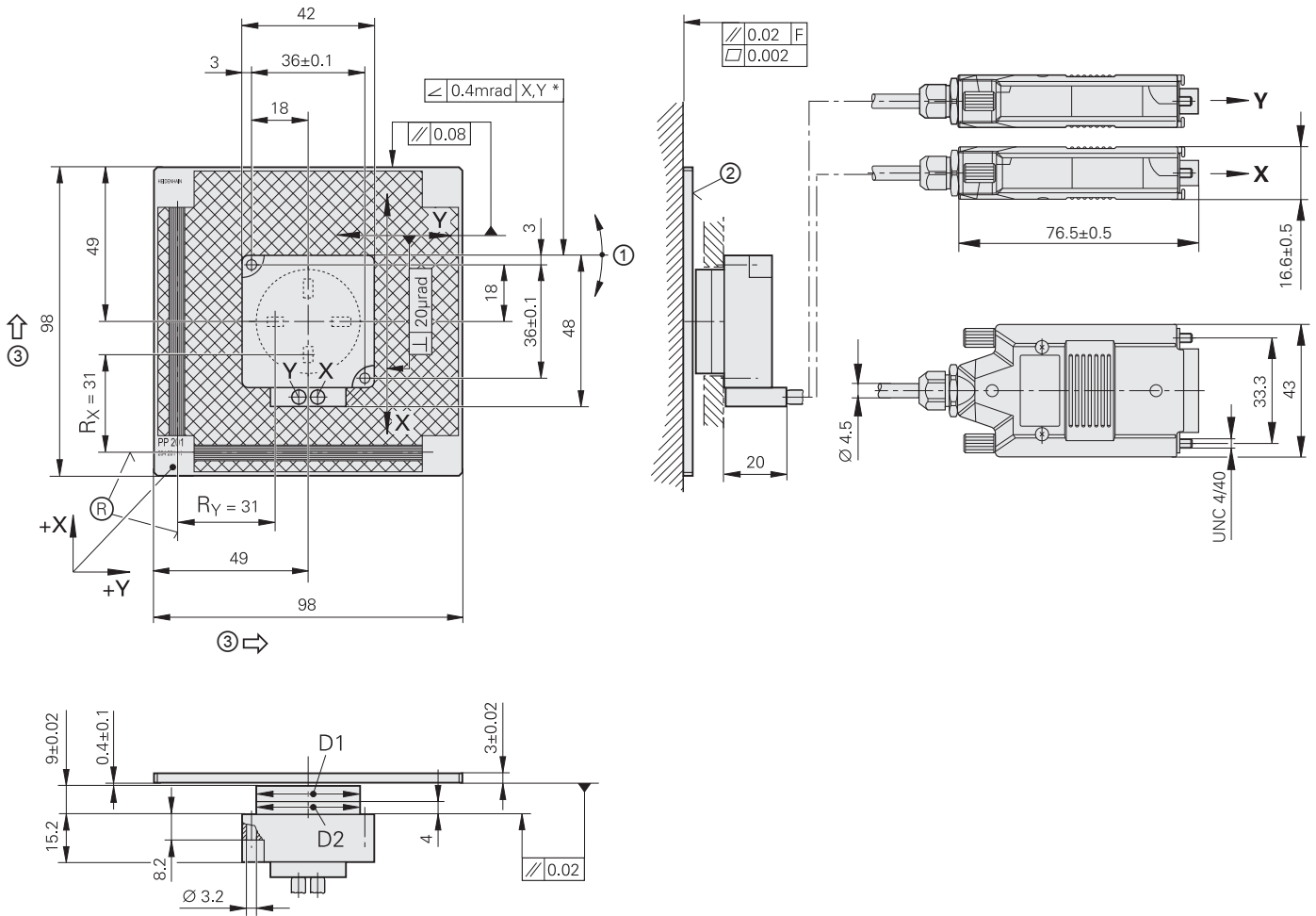

mm

 Tolerancing ISO 8015
 ISO 2768 - m H
 < 6 mm: ± 0.2 mm

- * = Maximum change during operation
- F = Machine guideway
- Ⓜ = Reference-mark position relative to center position shown
- 1 = Adjusted during mounting
- 2 = Graduation side
- 3 = Direction of motion of the scanning unit for ascending position values

D1	D2
$\varnothing 32.9 - 0.2$	$\varnothing 33 - 0.02 / - 0.10$

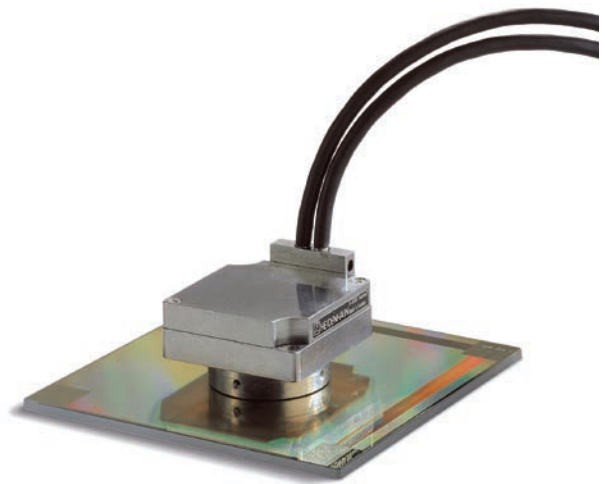

		PP 281 R
Measuring standard Coefficient of linear expansion		Two-coordinate TITANID phase grating on glass; grating period: 8 μm $\alpha_{\text{therm}} \approx 8 \cdot 10^{-6} \text{ K}^{-1}$
Accuracy grade		$\pm 2 \mu\text{m}$
Measuring area		68 mm x 68 mm, other measuring areas upon request
Reference marks ¹⁾		One reference mark in each axis, 3 mm after beginning of measuring length
Interface		$\sim 1 \text{ V}_{\text{PP}}$
Signal period		4 μm
Cutoff frequency	-3 dB	$\geq 300 \text{ kHz}$
Traversing speed		$\leq 72 \text{ m/min}$
Interpolation error RMS position noise		$\pm 12 \text{ nm}^3$ 2 nm (450 kHz^2)
Electrical connection		Cable (0.5 m) with 15-pin D-sub connector (male); interface electronics in the connector
Cable length		See the interface description; however, $\leq 30 \text{ m}$ (with HEIDENHAIN cable)
Supply voltage		DC 5 V $\pm 0.25 \text{ V}$
Current consumption		$< 185 \text{ mA}$ per axis
Vibration 55 Hz to 2000 Hz Shock 11 ms		$\leq 80 \text{ m/s}^2$ (EN 60068-2-6) $\leq 100 \text{ m/s}^2$ (EN 60068-2-27)
Operating temperature		0 $^{\circ}\text{C}$ to 50 $^{\circ}\text{C}$
Mass	Scanning head Grid plate Cable Connector	170 g (without cable) 75 g 37 g/m 140 g

¹⁾ The reference mark signal deviates from the interface specification in its zero crossovers K, L (see the mounting instructions)

²⁾ -3 dB cutoff frequency of the subsequent electronics

³⁾ With HEIDENHAIN interface electronics (e.g., EIB 741)

Interfaces

~ 1 V_{PP} incremental signals

HEIDENHAIN encoders with the ~ 1 V_{PP} interface provide voltage signals that are highly interpolatable.

The sinusoidal **incremental signals** A and B are phase-shifted by 90° elec. and have a typical amplitude of 1 V_{PP}. The illustrated sequence of output signals—with B lagging A—applies to the direction of motion shown in the dimension drawing.

The **reference mark signal** R has a unique assignment to the incremental signals. The output signal may be lower next to the reference mark.

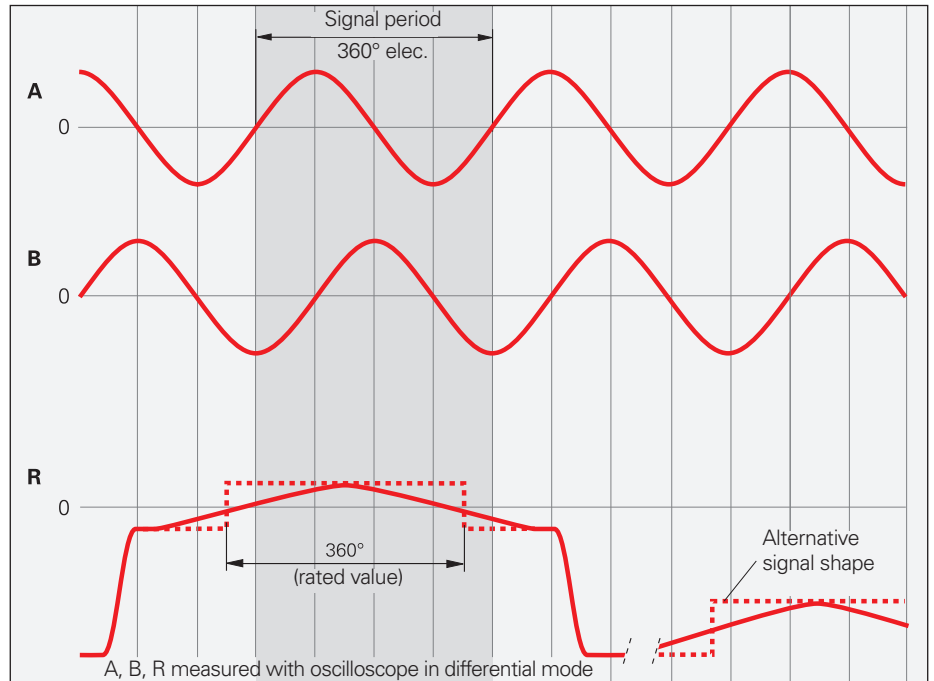

Further information:

For detailed descriptions of all available interfaces, as well as general electrical information, please refer to the *Interfaces of HEIDENHAIN Encoders* brochure.

□ TTL incremental signals

HEIDENHAIN encoders with the □ TTL interface incorporate electronics that digitize sinusoidal scanning signals with or without interpolation.

The **incremental signals** are transmitted as the square-wave pulse trains U_{a1} and U_{a2} , phase-shifted by 90° elec. The **reference mark signal** consists of one or more reference pulses U_{a0} , which are gated with the incremental signals. In addition, the integrated electronics produce their **inverted signals** $\overline{U_{a1}}$, $\overline{U_{a2}}$, and $\overline{U_{a0}}$ for noise-proof transmission. The illustrated sequence of output signals—with U_{a2} lagging U_{a1} —applies to the direction of motion shown in the dimension drawing.

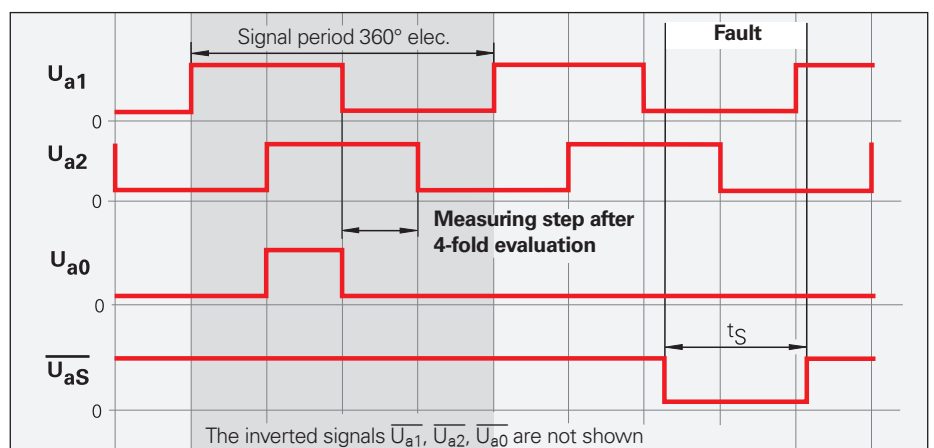

The **fault detection signal** $\overline{U_{aS}}$ indicates fault conditions such as an interruption in the supply lines, failure of the light source, etc.

The distance between two successive edges of the incremental signals U_{a1} and U_{a2} through 1-fold, 2-fold, or 4-fold evaluation is one **measuring step**.



Further information:

For detailed descriptions of all available interfaces, as well as general electrical information, please refer to the *Interfaces of HEIDENHAIN Encoders* brochure.

Limit switches

LIDA 400 encoders are equipped with two limit switches that enable limit-position detection and the formation of homing tracks. The limit switches are activated by differing adhesive magnets, thereby permitting precise switching of the right or left limit switches. The magnets can be configured in series for the creation of homing tracks. The **signals from the limit switches L1 and L2** are transmitted over separate lines and are therefore directly available. Nevertheless, the cable has only a very thin diameter of 3.7 mm in order to keep the forces on movable machine elements to a minimum.

The incremental signals conform with the 1 V_{PP} or TTL interface.



Further information:

For detailed descriptions of all available interfaces, as well as general electrical information, please refer to the *Interfaces of HEIDENHAIN Encoders* brochure.

Position detection

Besides the incremental graduation, the **LIF 4x1** and **LIP 60x1** encoders feature a homing track and limit switches for limit position detection.

The **signals for position detection H and L** are transmitted at the TTL level over the separate lines H and L and are therefore directly available. Yet the cable has only a very thin diameter of 4.5 mm (LIF 4x1) or 3.7 mm (LIP 60x1) in order to keep the forces on movable machine elements to a minimum.

The incremental signals conform with the 1 V_{PP} or TTL interface.



Further information:

For detailed descriptions of all available interfaces, as well as general electrical information, please refer to the *Interfaces of HEIDENHAIN Encoders* brochure.



Interfaces

Pin layouts (1 V_{PP}/TTL)

LIDA

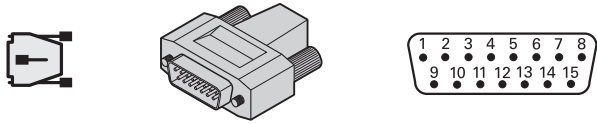
15-pin D-sub connector

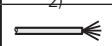

	Power supply				Incremental signals						Other signals				
	4	12	2	10	1	9	3	11	14	7	13	8	6	15	5
 TTL	U_P	Sensor ⁴⁾	0V	Sensor ⁴⁾	U_{a1}	\overline{U}_{a1}	U_{a2}	\overline{U}_{a2}	U_{a0}	\overline{U}_{a0}	\overline{U}_{aS}	L1 ³⁾	L2 ³⁾	PWT ¹⁾	Vacant
 1V _{PP}		5V	0V		A+	A-	B+	B-	R+	R-	As-signed				
 ²⁾	Brown/ Green	Blue	White/ Green	White	Brown	Green	Gray	Pink	Red	Black	Violet	Green/ Black	Yellow/ Black	Yellow	/

Cable shield on housing; **U_P** = Power supply voltage

Sensor: The sense line is connected in the encoder with the corresponding power line.

Vacant pins or wires must not be used.

¹⁾ TTL/11 μA_{PP} conversion for the PWT

²⁾ Color assignment of the connecting cable



³⁾ Valid only for the LIDA 400

⁴⁾ LIDA 200: vacant

LIF and LIP 6000

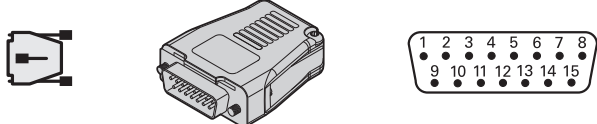
15-pin D-sub connector

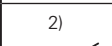

	Power supply				Incremental signals						Other signals				
	4	12	2	10	1	9	3	11	14	7	13	8	6	15	5
 TTL	U_P	Sensor	0V	Sensor	U_{a1}	\overline{U}_{a1}	U_{a2}	\overline{U}_{a2}	U_{a0}	\overline{U}_{a0}	\overline{U}_{aS}	H ³⁾	L ³⁾	PWT ¹⁾	Vacant
 1V _{PP}		5V	0V		A+	A-	B+	B-	R+	R-	As-signed				
 ²⁾	Brown/ Green	Blue	White/ Green	White	Brown	Green	Gray	Pink	Red	Black	Violet	Green/ Black	Yellow/ Black	Yellow	/

Cable shield on housing; **U_P** = Power supply voltage

Sensor: The sense line is connected in the encoder with the corresponding power line.

Vacant pins or wires must not be used.

¹⁾ TTL/11 μA_{PP} conversion for the PWT

²⁾ Color assignment of the connecting cable



³⁾ Valid only for the LIP 6000/LIF 400



Further information:

For detailed descriptions of cables, please refer to the *Cables and Connectors* brochure.

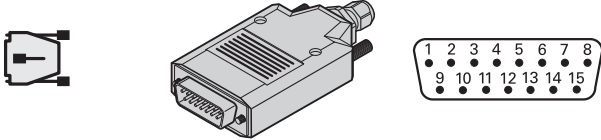
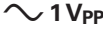
LIP 281 and PP 281 R

15-pin D-sub connector														
														
	Power supply				Incremental signals						Other signals			
	4	12	2	10	1	9	3	11	14	7	13	5	6/8	15
 1 V _{PP}	U _P	Sensor 5 V	0 V	Sensor 0 V	A+	A-	B+	B-	R+	R-	As- signed ¹⁾ Vacant ³⁾	As- signed ¹⁾ Vacant ³⁾	/	As- signed ¹⁾ Vacant ³⁾
 2)	Brown/ Green	Blue	White/ Green	White	Brown	Green	Gray	Pink	Red	Black	Violet	Red/ Black	/	Yellow

Cable shield on housing; **U_P** = Power supply voltage

Sensor: The sense line is connected in the encoder with the corresponding power line.





Vacant pins or wires must not be used.

¹⁾ Only for adjusting, do not use in normal operation

²⁾ Color assignment of the connecting cable

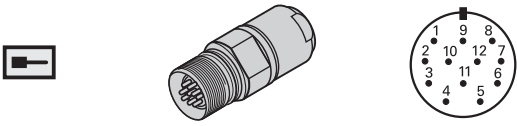
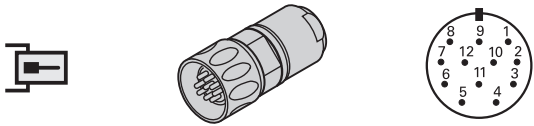
³⁾ PP 281 R

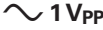
Alternative: LIDA 400

12-pin M23 coupling					12-pin M23 connector							
												
	Power supply				Incremental signals						Other signals	
	12	2	10	11	5	6	8	1	3	4	7	9
 TTL	U _P	Sensor U _P	0 V	Sensor 0 V	U _{a1}	\overline{U}_{a1}	U _{a2}	\overline{U}_{a2}	U _{a0}	\overline{U}_{a0}	\overline{U}_{aS}	PWT ¹⁾
 1 V _{PP}					A+	A-	B+	B-	R+	R-	L1	L2
 2)	Brown/ Green	Blue	White/ Green	White	Brown	Green	Gray	Pink	Red	Black	Violet	Yellow

Cable shield on housing; **U_P** = Power supply voltage

Sensor: The sense line is connected in the encoder with the corresponding power line.

Vacant pins or wires must not be used.

¹⁾ TTL/11 μA_{PP} conversion for the PWT

²⁾ Color assignment of the connecting cable



Further information:

For detailed descriptions of cables, please refer to the *Cables and Connectors* brochure.

Interfaces

Position values

The EnDat interface is a digital, **bidirectional** interface for encoders. It is capable of outputting **position values**, reading and updating information stored in the encoder, and storing new information in the encoder. Thanks to the **serial transmission method**, only **four signal lines** are required. The data (DATA) are transmitted in **synchronism** with the CLOCK signal from the subsequent electronics. The type of transmission (position values, parameters, diagnostics, etc.) is selected via mode commands that the subsequent electronics send to the encoder. Some functions are available only with EnDat 2.2 mode commands.

Ordering designation	Command set	Incremental signals
EnDat01	EnDat 2.1 or EnDat 2.2	With
EnDat21		Without
EnDat02	EnDat 2.2	With
EnDat22	EnDat 2.2	Without

Versions of the EnDat interface

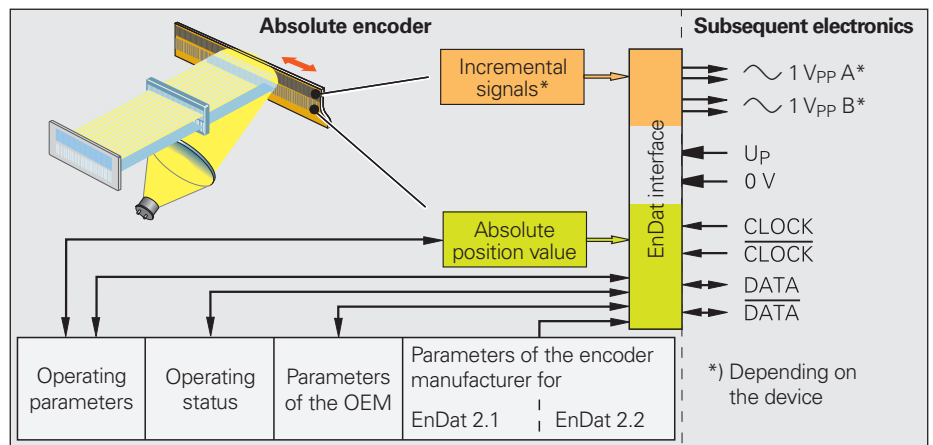

Further information:

For detailed descriptions of all available interfaces, as well as general electrical information, please refer to the *Interfaces of HEIDENHAIN Encoders* brochure.

EnDat pin layout

8-pin M12 coupling					15-pin D-sub connector			
	Power supply				Serial data transmission			
	8	2	5	1	3	4	7	6
	4	12	2	10	5	13	8	15
	Up	Sensor Up	0V	Sensor 0V	DATA	DATA	CLOCK	CLOCK
	Brown/Green	Blue	White/Green	White	Gray	Pink	Violet	Yellow

Cable shield connected to housing; **Up** = Power supply voltage

Sensor: The sense line is connected in the encoder with the corresponding power line. Vacant pins or wires must not be used.



Further information:

For detailed descriptions of cables, please refer to the *Cables and Connectors* brochure.

Fanuc and Mitsubishi pin layouts

Fanuc pin layout

HEIDENHAIN encoders with the code letter F following the model designation are suitable for connection to Fanuc controls and drive systems.

Fanuc Serial Interface – α Interface







Ordering designation: Fanuc05
high speed, one-pair transmission
contains the α interface (normal and high speed, two-pair transmission)

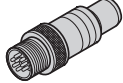

Further information:

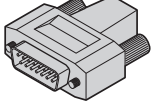
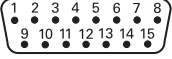
For detailed descriptions of cables, please refer to the *Cables and Connectors* brochure.

Fanuc pin layout

8-pin M12 coupling					15-pin D-sub connector				
									
	Power supply				Serial data transmission				
	8	2	5	1	3	4	7	6	
	4	12	2	10	5	13	8	15	
	U_P	Sensor U_P	0V	Sensor 0V	Serial Data	Serial Data	Request	Request	
	Brown/Green	Blue	White/Green	White	Gray	Pink	Violet	Yellow	

Cable shield connected to housing; U_P = Power supply voltage

Sensor: The sense line is connected in the encoder with the corresponding power line.

Vacant pins or wires must not be used.

Mitsubishi pin layout







HEIDENHAIN encoders with the code letter M following the model designation are suitable for connection to Mitsubishi controls and drive systems.

Mitsubishi high speed interface

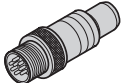
- Ordering designation: Mitsu01
two-pair transmission
- Ordering designation: Mit02-4
Generation 1, two-pair transmission

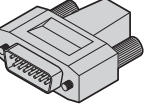
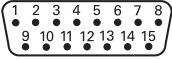
- Ordering designation: Mit02-2
Generation 1, one-pair transmission
- Ordering designation: Mit03-4
Generation 2, two-pair transmission

Mitsubishi pin layout

8-pin M12 coupling					15-pin D-sub connector				
									
	Power supply				Serial data transmission				
	8	2	5	1	3	4	7	6	
	4	12	2	10	5	13	8	15	
Mit03-4	U_P	Sensor U_P	0V	Sensor 0V	Serial Data	Serial Data	Request Frame	Request Frame	
Mit02-2					Vacant	Vacant	Request/ Data	Request/ Data	
	Brown/Green	Blue	White/Green	White	Gray	Pink	Violet	Yellow	

Cable shield connected to housing; U_P = Power supply voltage

Sensor: The sense line is connected in the encoder with the corresponding power line.

Vacant pins or wires must not be used.

Panasonic and Yaskawa pin layouts

Panasonic pin layout

HEIDENHAIN encoders with the code letter P following the model designation are suitable for connection to Panasonic controls and drive systems.







- Ordering designation: Pana01

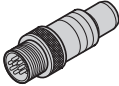

Further information:

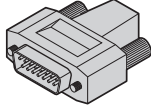
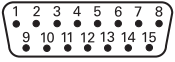
For detailed descriptions of cables, please refer to the *Cables and Connectors* brochure.

Panasonic pin layout

8-pin M12 coupling					15-pin D-sub connector				
									
	Power supply				Serial data transmission				
	8	2	5	1	3	4	7	6	
	4	12	2	10	5	13	8	15	
	U_P	Sensor U_P	0V	Sensor 0V	Vacant ¹⁾	Vacant ¹⁾	Request Data	Request Data	
	Brown/Green	Blue	White/Green	White	Gray	Pink	Violet	Yellow	

Cable shield connected to housing; U_P = Power supply voltage

Sensor: The sense line is connected in the encoder with the corresponding power line.

Vacant pins or wires must not be used.

¹⁾ Required for adjustment/testing with the PWM 21

Yaskawa pin layout

HEIDENHAIN encoders with the code letter Y following the model designation are suitable for connection to Yaskawa controls and drive systems.







- Ordering designation: YEC07

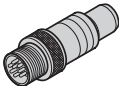

Further information:

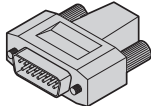
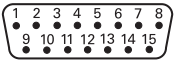
For detailed descriptions of cables, please refer to the *Cables and Connectors* brochure.

Yaskawa pin layout

8-pin M12 coupling					15-pin D-sub connector				
									
	Power supply				Serial data transmission				
	8	2	5	1	3	4	7	6	
	4	12	2	10	5	13	8	15	
	U_P	Sensor U_P	0V	Sensor 0V	Vacant ¹⁾	Vacant ¹⁾	Data	Data	
	Brown/Green	Blue	White/Green	White	Gray	Pink	Violet	Yellow	

Cable shield connected to housing; U_P = Power supply voltage

Sensor: The sense line is connected in the encoder with the corresponding power line.

Vacant pins or wires must not be used.

¹⁾ Required for adjustment/testing with the PWM 21

Testing equipment and diagnostics

HEIDENHAIN encoders provide all of the information needed for commissioning, monitoring, and diagnostics. The type of information available depends on whether the encoder is incremental or absolute and on which interface is being used.

Incremental encoders mainly have 1 V_{PP} TTL, or HTL interfaces. TTL and HTL encoders monitor their signal amplitudes internally and generate a simple fault detection signal. With 1 V_{PP} signals, the analysis of output signals is possible only with external testing devices or via computation in the subsequent electronics (analog diagnostics interface).

Absolute encoders employ serial data transmission. Depending on the interface, additional 1 V_{PP} incremental signals can be output. The signals are extensively monitored within the encoder. The monitoring results (particularly valuation numbers) can be transmitted to the subsequent electronics along with the position values via the serial interface (digital diagnostics interface). The following information is available:

- Error message: position value is not reliable
- Warning: an internal functional limit of the encoder has been reached
- Valuation numbers:
 - Detailed information about the encoder's function reserve
 - Identical scaling for all HEIDENHAIN encoders
 - Cyclic reading capability

The subsequent electronics are able to evaluate the current status of the encoder with low resource expenditure, including in closed-loop operation.

For the analysis of these encoders, HEIDENHAIN offers the appropriate PWM inspection devices and PWT testing devices. Based on how these devices are integrated, a distinction is made between two types of diagnostics:

- Encoder diagnostics: the encoder is connected directly to the inspection or testing device, thereby enabling a detailed analysis of encoder functions.
- Diagnostics in the control loop: the PWM testing unit is linked into the closed control loop (e.g., via a suitable testing adapter). This enables real-time diagnosis of the machine or system during operation. The available functions depend on the interface.

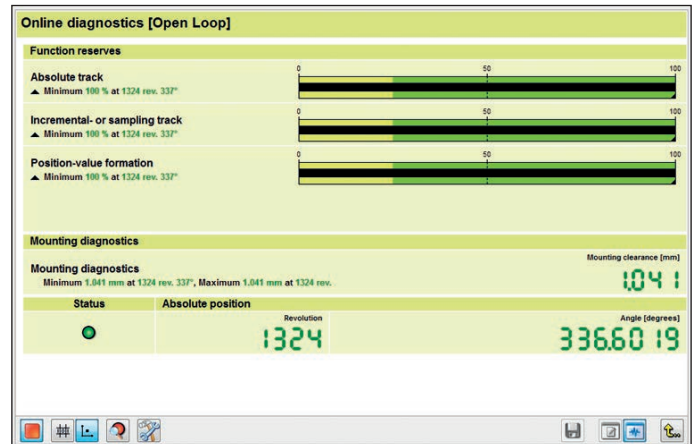

Diagnostics with the PWM 21 and ATS software

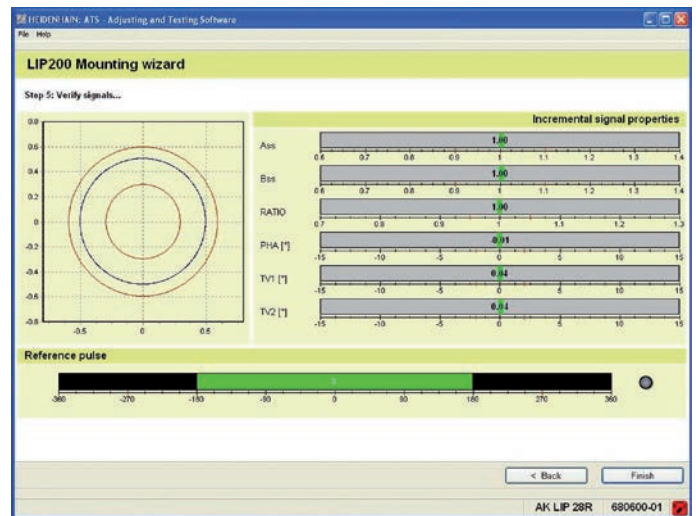

Commissioning with the PWM 21 and ATS software

Testing equipment and diagnostics

PWM 21

The PWM 21 phase-angle measuring unit, in conjunction with the included ATS adjusting and testing software, serves as an adjusting and testing package for the diagnosis and adjustment of HEIDENHAIN encoders.



For more information, see the *PWM 21/ATS Software* Product Information document.

	PWM 21
Encoder input	<ul style="list-style-type: none"> • EnDat 2.1 or EnDat 2.2 (absolute value with or without incremental signals) • DRIVE-CLiQ • Fanuc Serial Interface • Mitsubishi high speed interface • Yaskawa Serial Interface • SSI • 1 V_{PP}/TTL/11 μA_{PP}
Interface	USB 2.0
Supply voltage	AC 100 V to 240 V or DC 24 V
Dimensions	258 mm x 154 mm x 55 mm

	ATS
Languages	German or English (selectable)
Functions	<ul style="list-style-type: none"> • Position display • Connection dialog • Diagnostics • Mounting wizard for the EBI/ECI/EQI, LIP 200, LIC 4100, and others • Additional functions (if supported by the encoder) • Memory contents
System requirements and recommendations	PC (dual-core processor > 2 GHz) RAM > 2 GB Operating system: Windows XP, Vista, 7 (32-bit/64-bit), 8, 10 200 MB of available hard-disk space

DRIVE-CLiQ is a registered trademark of Siemens AG

PWT 101

The PWT 101 is a testing device for the functional testing and adjustment of incremental and absolute HEIDENHAIN encoders. Thanks to its compact and rugged design, the PWT 101 is ideal for portable use.



	PWT 101
Encoder input only for HEIDENHAIN encoders	<ul style="list-style-type: none"> • EnDat • Fanuc Serial Interface • Mitsubishi high speed interface • Panasonic Serial Interface • Yaskawa Serial Interface • 1 V_{PP} with Z1 track • 1 V_{PP} • 11 μA_{PP} • TTL
Display	4.3-inch touchscreen
Supply voltage	DC 24 V Power consumption: max. 15 W
Operating temperature	0 °C to 40 °C
Protection EN 60529	IP20
Dimensions	Approx. 145 mm x 85 mm x 35 mm

Interface electronics

Interface electronics from HEIDENHAIN adapt the encoder signals to the interface of the subsequent electronics. They are used when the subsequent electronics cannot directly process the output signals from HEIDENHAIN encoders, or when additional interpolation of the signals is necessary.

Input signals of the interface electronics

Interface electronics from HEIDENHAIN can be connected to encoders with the following sinusoidal signals: 1 V_{PP} (voltage signals) or 11 μA_{PP} (current signals). Encoders with the EnDat or SSI serial interfaces can also be connected to various interface electronics.

Output signals of the interface electronics

The interface electronics are available with the following interfaces to the subsequent electronics:

- TTL square-wave pulse trains
- EnDat 2.2
- DRIVE-CLiQ
- Fanuc Serial Interface
- Mitsubishi high speed interface
- Yaskawa Serial Interface
- PROFIBUS

Interpolation of the sinusoidal input signals

The interface electronics perform signal conversion and interpolate the sinusoidal encoder signals. This permits finer measuring steps, resulting in higher control quality and superior positioning behavior.

Generation of a position value

Some interface electronics feature an integrated counting function. Starting from the last set reference point, an absolute position value is generated and output to the subsequent electronics when the reference mark is traversed.

Box design



Plug design



Version for integration



Top-hat rail design



Outputs		Inputs		Design – IP rating	Interpolation ¹⁾ or subdivision	Model	
Interface	Quantity	Interface	Quantity				
□□TTL	1	~ 1 V _{PP}	1	Box design – IP65	5/10-fold	IBV 101	
					20/25/50/100-fold	IBV 102	
					Without interpolation	IBV 600	
					25/50/100/200/400-fold	IBV 660B	
				Plug design – IP40	5/10/20/25/50/100-fold	APE 371	
				Version for integration – IP00	5/10-fold	IDP 181	
		20/25/50/100-fold	IDP 182				
		~ 11 μA _{PP}	1	Box design – IP65	1	5/10-fold	EXE 101
						20/25/50/100-fold	EXE 102
						Version for integration – IP00	5-fold
□□TTL/ ~ 1 V _{PP} (adjustable)	2	~ 1 V _{PP}	1	Box design – IP65	2-fold	IBV 6072	
					5/10-fold	IBV 6172	
					5/10-fold and 20/25/50/100-fold	IBV 6272	
EnDat 2.2	1	~ 1 V _{PP}	1	Box design – IP65	≤ 16384-fold subdivision	EIB 192	
				Plug design – IP40	≤ 16384-fold subdivision	EIB 392	
			2	Box design – IP65	≤ 16384-fold subdivision	EIB 1512	
DRIVE-CLiQ	1	EnDat 2.2	1	Box design – IP65	–	EIB 2391 S	
Fanuc Serial Interface	1	~ 1 V _{PP}	1	Box design – IP65	≤ 16384-fold subdivision	EIB 192 F	
				Plug design – IP40	≤ 16384-fold subdivision	EIB 392 F	
			2	Box design – IP65	≤ 16384-fold subdivision	EIB 1592 F	
Mitsubishi high speed interface	1	~ 1 V _{PP}	1	Box design – IP65	≤ 16384-fold subdivision	EIB 192 M	
				Plug design – IP40	≤ 16384-fold subdivision	EIB 392 M	
			2	Box design – IP65	≤ 16384-fold subdivision	EIB 1592 M	
Yaskawa Serial Interface	1	EnDat 2.2 ²⁾	1	Plug design – IP40	–	EIB 3391 Y	
PROFIBUS DP	1	EnDat 2.1; EnDat 2.2	1	Top-hat rail design	–	PROFIBUS gateway	

¹⁾ Switchable

²⁾ Only for the LIC 4100 with a 5 nm measuring step, or the LIC 2100 with a 50 nm or 100 nm measuring step

HEIDENHAIN

Mastering nanometer accuracy



HEIDENHAIN

DR. JOHANNES HEIDENHAIN GmbH

Dr.-Johannes-Heidenhain-Straße 5

83301 Traunreut, Germany

☎ +49 8669 31-0

☎ +49 8669 32-5061

✉ info@heidenhain.de

www.heidenhain.com



HEIDENHAIN
worldwide