



HEIDENHAIN



**Functional
Safety**

Product Information

ECN 1325
EQN 1337

Absolute Rotary Encoders
with Tapered Shaft for
Safety-Related Applications

ID 1178026-03

ID 1178026-53

ID 1178027-01

ID 1178027-53

05/2022

ECN 1325, EQN 1337

Rotary encoders for absolute position feedback with safe singleturn information

- 65 mm installation diameter
- 07B expanding ring coupling
- 65B tapered shaft



Functional Safety

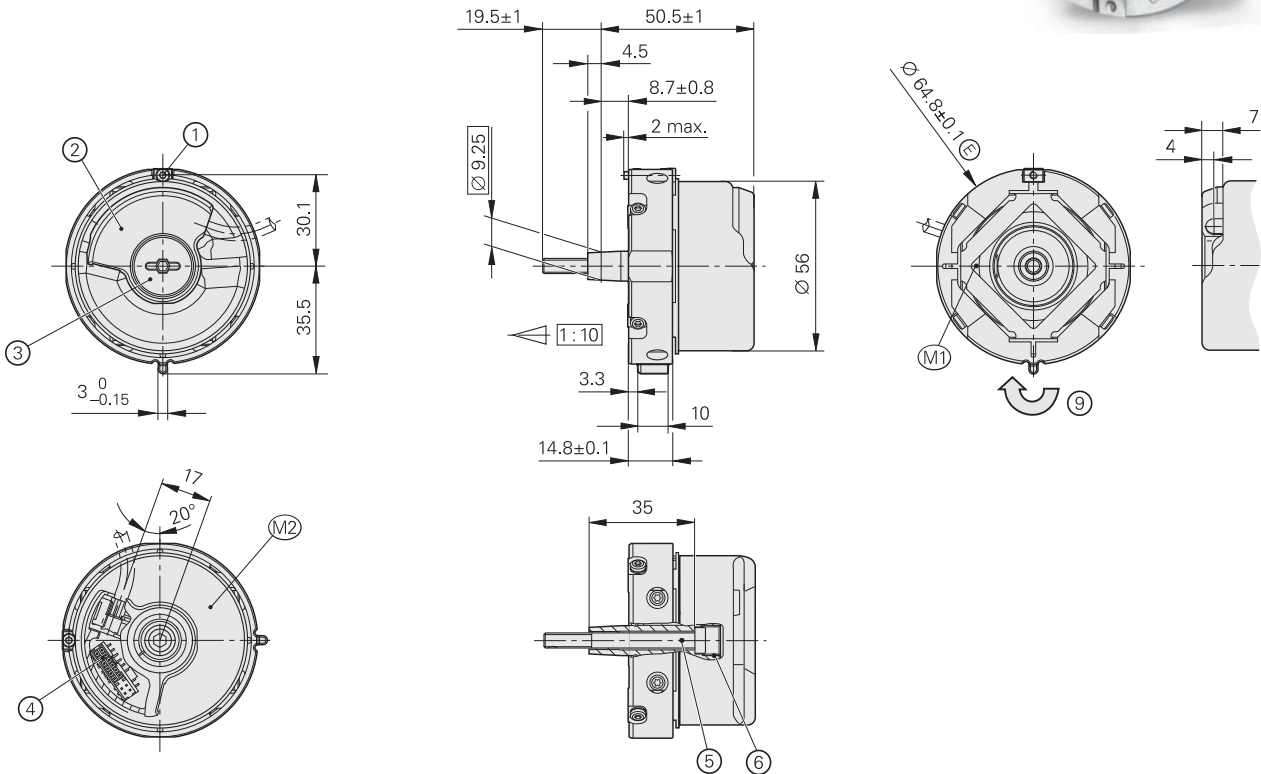

Required mating dimensions

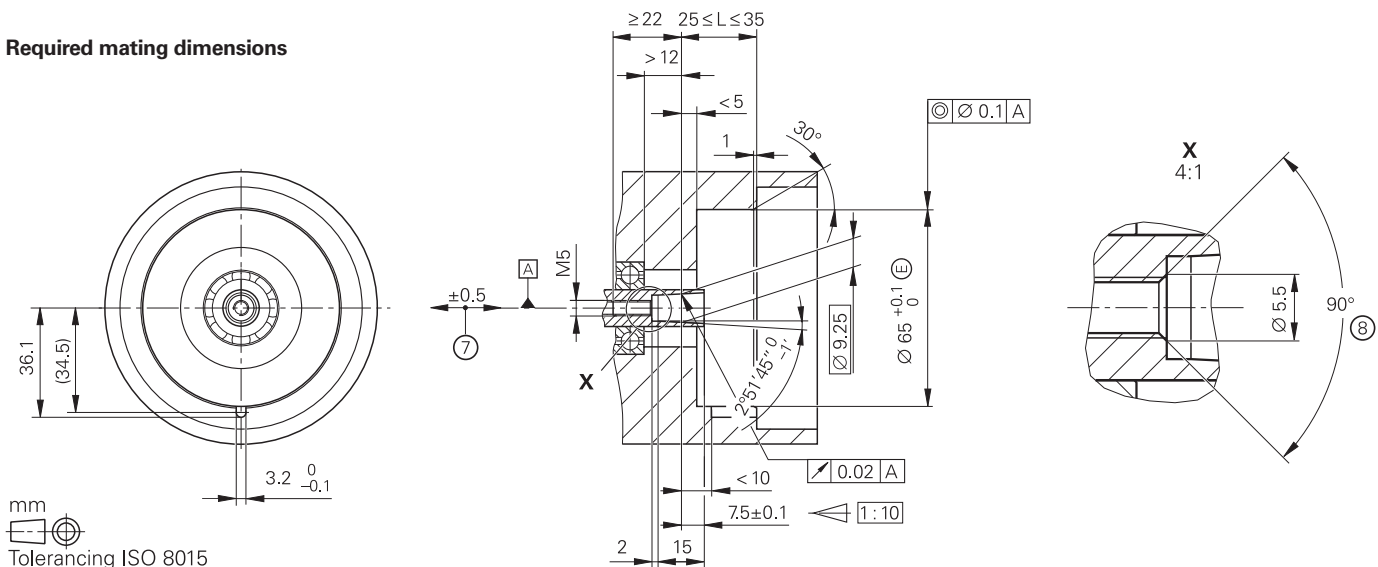

mm
 Tolerancing ISO 8015
 ISO 2768:1989-mH
 ≤ 6 mm: ±0.2 mm

- ☐ = Bearing of mating shaft
- M1 = Measuring point for operating temperature
- M2 = Measuring point for vibration (see D741714)
- 1 = Clamping screw for coupling ring: width A/F 2; tightening torque: 1.25 Nm -0.2 Nm
- 2 = Die-cast cover
- 3 = Screw plug: widths A/F 3 and 4; tightening torque: 5 Nm +0.5 Nm
- 4 = 16-pin (12+4-pin) header
- 5 = Screw: DIN 6912 - M5x50 - 08.8 - MKL; width A/F 4; tightening torque: 5 Nm +0.5 Nm
- 6 = M10 back-off thread
- 7 = Compensation of mounting tolerances and thermal expansion; no dynamic movement permitted
- 8 = Chamfer at start of thread is mandatory for material bonding anti-rotation lock
- 9 = Direction of shaft rotation for ascending position values

Specifications	ECN 1325 singleturn	EQN 1337 multiturn
Functional safety for applications with up to	As a single-encoder system for monitoring functions and closed-loop functions <ul style="list-style-type: none"> • SIL 2 as per EN 61508 (further basis for testing: IEC 61800-5-3) • Category 3, PL d, according to EN ISO 13849-1:2015 Safe in the singleturn range	
PFH ¹⁾	$\leq 10 \cdot 10^{-9}$ (probability of dangerous failure per hour)	
Safe position ²⁾	<i>Encoder:</i> $\pm 1.76^\circ$ (safety-related measuring step: SM = 0.7°) <i>Mechanical coupling:</i> $\pm 2^\circ$ (exclusion for loosening of shaft and stator coupling, designed for accelerations of $\leq 300 \text{ m/s}^2$)	
Interface/ordering designation	EnDat 2.2 / EnDat22	
Position values per revolution	33554432 (25 bits)	
Revolutions	–	4096 (12 bits)
Calculation time t_{cal} /clock frequency	$\leq 7 \mu\text{s}/\leq 16 \text{ MHz}$	
System accuracy at 20 °C	$\pm 20''$	
Supply voltage	DC 3.6 V to 14 V	
Power consumption (maximum)	At 3.6 V: $\leq 600 \text{ mW}$; at 14 V: $\leq 700 \text{ mW}$	At 3.6 V: $\leq 700 \text{ mW}$; at 14 V: $\leq 800 \text{ mW}$
Current consumption (typical)	At 5 V: 80 mA (without load)	At 5 V: 95 mA (without load)
Electrical connection	<i>PCB connector:</i> 16-pin (12+4-pin), with connection for external temperature sensor ³⁾	
Cable length ⁴⁾	$\leq 100 \text{ m}$ (at clock frequency $\leq 8 \text{ MHz}$) $\leq 20 \text{ m}$ (at clock frequency $\leq 16 \text{ MHz}$)	
Shaft	65B tapered shaft $\varnothing 9.25 \text{ mm}$; taper 1:10	
Permissible shaft speed	$\leq 15000 \text{ rpm}$	$\leq 12000 \text{ rpm}$
Starting torque at 20 °C (typical)	$\leq 0.01 \text{ Nm}$	
Moment of inertia of rotor	$2.6 \cdot 10^{-6} \text{ kgm}^2$	
Angular acceleration of rotor	$\leq 1 \cdot 10^5 \text{ rad/s}^2$	
Natural frequency f_N (typical)	$\geq 1800 \text{ Hz}$	
Permiss. axial motion of measured shaft	$\leq \pm 0.5 \text{ mm}$	
Vibration 55 Hz to 2000 Hz Shock 6 ms	$\leq 300 \text{ m/s}^2$ ⁵⁾ (EN 60068-2-6); 10 Hz to 55 Hz constant over 4.9 mm peak to peak $\leq 2000 \text{ m/s}^2$ (EN 60068-2-27)	
Operating temperature	$-40 \text{ }^\circ\text{C}$ to $115 \text{ }^\circ\text{C}$	
Trigger threshold for exceeded temperature error message ⁶⁾	$125 \text{ }^\circ\text{C}$ (measuring accuracy of the internal temperature sensor: $\pm 1 \text{ K}$)	
Relative humidity	$\leq 93\%$ (40 °C/21 d as per EN 60068-2-78), condensation excluded	
Protection EN 60529	IP40 (read about insulation under <i>Electrical safety</i> in the <i>Interfaces of HEIDENHAIN Encoders</i> brochure; contamination through the ingress of liquids must be avoided)	
Mass	$\approx 0.25 \text{ kg}$	
ID number	1178026-03 1178026-53 ⁷⁾	1178027-01 1178027-53 ⁷⁾

¹⁾ For use at $\leq 2000 \text{ m}$ above sea level
($\leq 6000 \text{ m}$ above seal level upon request)

²⁾ Further tolerances may arise in the downstream electronics after position value comparison (contact the manufacturer)

³⁾ Connectable temperature sensor for rotary encoders: KTY 84-130 or PT 1000 (see *Temperature measurement in motors* in the *Encoders for Servo Drives* brochure)

⁴⁾ See the EnDat description in the *Interfaces of HEIDENHAIN Encoders* brochure

⁵⁾ Valid at room temperature in accordance with the standard; at operating temperatures of up to $100 \text{ }^\circ\text{C}$: $\leq 300 \text{ m/s}^2$; up to $115 \text{ }^\circ\text{C}$: $\leq 150 \text{ m/s}^2$
($\geq 100 \text{ }^\circ\text{C}$: 10 Hz to 55 Hz constant over 2.45 mm peak to peak)

⁶⁾ The internal temperature evaluation is not designed with functional safety

⁷⁾ In collective package upon request

Mounting

The tapered shaft of the rotary encoder is pressed onto the measured shaft and fastened with a central screw. It is particularly important to ensure that the positive-locking element of the stator coupling securely engages the corresponding slot in the measured shaft. Use a central screw with material-bonding anti-rotation lock (see Mounting accessories). The stator coupling is clamped by means of an axially tightenable screw in a locating hole.

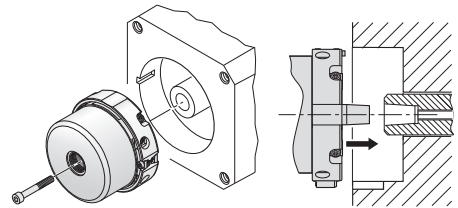

More information:

For the customer-side mounting design, the material specifications for steel apply to the customer-side shaft. For the customer-side stator, the material specifications for aluminum apply.

Also comply with the other material properties in the *Encoders for Servo Drives* brochure (ID 208922-xx).

Mounting accessories

Screws

Screws (central screw, mounting screws) are not included in delivery and can be ordered separately.

ECN 1325, EQN 1337	Screws ¹⁾		Quantity
Central screw for shaft fastening	DIN 6912 – M5x50 – 08.8 – MKL	ID 202264-54	10 or 100

¹⁾ With coating for material bonding anti-rotation lock

Please note the information on screws from HEIDENHAIN in the *Encoders for Servo Drives* brochure, under the heading *Screws with material bonding anti-rotation lock* in the chapter *General mechanical information*.

Mounting aid

To avoid damage to the cable, use the mounting aid to connect and disconnect the cable assembly. The pulling force must be applied solely to the connector and not to the wires.

ID 1075573-01

For more mounting information and mounting aids, see the Mounting Instructions and the *Encoders for Servo Drives* brochure. The mounting quality can be inspected with the PWM 21 and ATS software.



Electrical connection

Pin layout

16-pin (12+4-pin) PCB connector											
	Power supply				Serial data transmission				Other signals ¹⁾		
12+4	1b	6a	4b	3a	6b	1a	2b	5a	1a ²⁾	1b ²⁾	2a/2b
	U _P	Sensor U _P	0V	Sensor 0V	DATA	$\overline{\text{DATA}}$	CLOCK	$\overline{\text{CLOCK}}$	T+	T-	/

¹⁾ Only for adapter cables inside the motor housing

²⁾ Connections for an external temperature sensor (see *Temperature measurement in motors* in the *Encoders for Servo Drives* brochure)

Cable shield connected to housing; **U_P** = Power supply voltage; **T** = Temperature

Sensor: The sense line is connected in the encoder with the corresponding power line.

Vacant pins or wires must not be used!

Note for safety-related applications: Only completely assembled HEIDENHAIN cables are qualified.

Do not modify cables or exchange their connectors without first consulting with HEIDENHAIN Traunreut!

HEIDENHAIN

DR. JOHANNES HEIDENHAIN GmbH

Dr.-Johannes-Heidenhain-Str. 5

83301 Traunreut, Germany

+49 8669 31-0

+49 8669 32-5061

info@heidenhain.de

www.heidenhain.com

This Product Information document supersedes all previous editions, which thereby become invalid. The basis for ordering from HEIDENHAIN is always the Product Information document edition valid when the order is placed.



More information:

Comply with the requirements described in the following documents to ensure correct and intended operation:

- Brochure: *Encoders for Servo Drives* 208922-xx
- Brochure: *Cables and Connectors* 1206103-xx
- Brochure: *Interfaces of HEIDENHAIN Encoders* 1078628-xx
- Operating Instructions 1378812-xx
- Mounting Instructions: *ECN 1325, EQN 1337* 1378983-xx
- Technical Information: *Safety-Related Position Measuring Systems* 596632-xx
- For implementation in a safe control or inverter: *Specification document* 533095-xx